



KONICA MINOLTA

**SERVICE MANUAL**

FIELD SERVICE

---

# **bizhub**

## **C353/C253/C203**

This service manual is designed for machine with  
firmware card ver. 88 and onward.

# FIELD SERVICE TOTAL CONTENTS

SAFETY AND IMPORTANT WARNING ITEMS .....	S-1
IMPORTANT NOTICE .....	S-1
DESCRIPTION ITEMS FOR DANGER, WARNING AND CAUTION .....	S-1
SAFETY WARNINGS .....	S-2
WARNING INDICATIONS ON THE MACHINE .....	S-18
MEASURES TO TAKE IN CASE OF AN ACCIDENT .....	S-20
Composition of the service manual .....	C-1
Notation of the service manual .....	C-2

## bizhub C353/C253/C203 Main body

General .....	1
Maintenance .....	11
Adjustment/Setting.....	191
Troubleshooting.....	463
Appendix.....	601

## Standard controller

General .....	1
Maintenance .....	3
Troubleshooting.....	31

## i-Option LK-101/102/103

General .....	1
Adjustment/Setting.....	3
Troubleshooting.....	21

## DF-611

General .....	1
Maintenance .....	5
Adjustment/Setting.....	27
Troubleshooting.....	53

## PC-104/204

General .....	1
Maintenance .....	3
Adjustment/Setting.....	17
Troubleshooting.....	23

## PC-405

General .....	1
Maintenance .....	3
Adjustment/Setting .....	21
Troubleshooting .....	29

## FS-519/PK-515/OT-602

General .....	1
Maintenance .....	7
Adjustment/Setting .....	59
Troubleshooting .....	73

## MT-502

General .....	1
Maintenance .....	3
Adjustment/Setting .....	7
Troubleshooting .....	11

## SD-505

General .....	1
Maintenance .....	3
Adjustment/Setting .....	25
Troubleshooting .....	37

## JS-505

General .....	1
Maintenance .....	3
Adjustment/Setting .....	15
Troubleshooting .....	19

## FS-609/PK-501

General .....	1
Maintenance .....	5
Adjustment/Setting .....	33
Troubleshooting .....	63

# SAFETY AND IMPORTANT WARNING ITEMS

Read carefully the safety and important warning items described below to understand them before doing service work.

## IMPORTANT NOTICE

Because of possible hazards to an inexperienced person servicing this product as well as the risk of damage to the product, KONICA MINOLTA BUSINESS TECHNOLOGIES, INC. (hereafter called the KMBT) strongly recommends that all servicing be performed only by KMBT-trained service technicians.

Changes may have been made to this product to improve its performance after this Service Manual was printed. Accordingly, KMBT does not warrant, either explicitly or implicitly, that the information contained in this service manual is complete and accurate.

The user of this service manual must assume all risks of personal injury and/or damage to the product while servicing the product for which this service manual is intended.



Therefore, this service manual must be carefully read before doing service work both in the course of technical training and even after that, for performing maintenance and control of the product properly.

Keep this service manual also for future service.













## DESCRIPTION ITEMS FOR DANGER, WARNING AND CAUTION

In this Service Manual, each of three expressions “⚠ DANGER”, “⚠ WARNING”, and “⚠ CAUTION” is defined as follows together with a symbol mark to be used in a limited meaning.

When servicing the product, the relevant works (disassembling, reassembling, adjustment, repair, maintenance, etc.) need to be conducted with utmost care.

-  **DANGER: Action having a high possibility of suffering death or serious injury**
-  **WARNING: Action having a possibility of suffering death or serious injury**
-  **CAUTION: Action having a possibility of suffering a slight wound, medium trouble, and property damage**

Symbols used for safety and important warning items are defined as follows:

	:Precaution when servicing the product.		General precaution		Electric hazard		High temperature
	:Prohibition when servicing the product.		General prohibition		Do not touch with wet hand		Do not disassemble
	:Direction when servicing the product.		General instruction		Unplug		Ground/Earth

## SAFETY WARNINGS

### [1] MODIFICATIONS NOT AUTHORIZED BY KONICA MINOLTA BUSINESS TECHNOLOGIES, INC.

KONICA MINOLTA brand products are renowned for their high reliability. This reliability is achieved through high-quality design and a solid service network. Product design is a highly complicated and delicate process where numerous mechanical, physical, and electrical aspects have to be taken into consideration, with the aim of arriving at proper tolerances and safety factors. For this reason, unauthorized modifications involve a high risk of degradation in performance and safety. Such modifications are therefore strictly prohibited. The points listed below are not exhaustive, but they illustrate the reasoning behind this policy.

<b>DANGER</b>	
<ul style="list-style-type: none"> <li>• Using any cables or power cord not specified by KMBT.</li> </ul>	
<ul style="list-style-type: none"> <li>• Using any fuse or thermostat not specified by KMBT. Safety will not be assured, leading to a risk of fire and injury.</li> </ul>	
<ul style="list-style-type: none"> <li>• Disabling fuse functions or bridging fuse terminals with wire, metal clips, solder or similar object.</li> </ul>	
<ul style="list-style-type: none"> <li>• Disabling relay functions (such as wedging paper between relay contacts)</li> </ul>	
<ul style="list-style-type: none"> <li>• Disabling safety functions (interlocks, safety circuits, etc.) Safety will not be assured, leading to a risk of fire and injury.</li> </ul>	
<ul style="list-style-type: none"> <li>• Making any modification to the product unless instructed by KMBT</li> </ul>	
<ul style="list-style-type: none"> <li>• Using parts not specified by KMBT</li> </ul>	

## [2] POWER PLUG SELECTION

In some countries or areas, the power plug provided with the product may not fit wall outlet used in the area. In that case, it is obligation of customer engineer (hereafter called the CE) to attach appropriate power plug or power cord set in order to connect the product to the supply.

### Power Cord Set or Power Plug

#### WARNING

- Use power supply cord set which meets the following criteria:
  - provided with a plug having configuration intended for the connection to wall outlet appropriate for the product's rated voltage and current, and
  - the plug has pin/terminal(s) for grounding, and
  - provided with three-conductor cable having enough current capacity, and
  - the cord set meets regulatory requirements for the area.

Use of inadequate cord set leads to fire or electric shock.
- Attach power plug which meets the following criteria:
  - having configuration intended for the connection to wall outlet appropriate for the product's rated voltage and current, and
  - the plug has pin/terminal(s) for grounding, and
  - meets regulatory requirements for the area.

Use of inadequate cord set leads to the product connecting to inadequate power supply (voltage, current capacity, grounding), and may result in fire or electric shock.
- Conductors in the power cable must be connected to terminals of the plug according to the following order:
  - Black or Brown:L (line)
  - White or Light Blue:N (neutral)
  - Green/Yellow:PE (earth)

Wrong connection may cancel safeguards within the product, and results in fire or electric shock.



### [3] CHECKPOINTS WHEN PERFORMING ON-SITE SERVICE

KONICA MINOLTA brand products are extensively tested before shipping, to ensure that all applicable safety standards are met, in order to protect the customer and customer engineer (hereafter called the CE) from the risk of injury. However, in daily use, any electrical equipment may be subject to parts wear and eventual failure. In order to maintain safety and reliability, the CE must perform regular safety checks.

#### 1. Power Supply

## Connection to Power Supply

### WARNING

- Check that mains voltage is as specified.  
Connection to wrong voltage supply may result in fire or electric shock. 

- Connect power plug directly into wall outlet having same configuration as the plug.

Use of an adapter leads to the product connecting to inadequate power supply (voltage, current capacity, grounding), and may result in fire or electric shock.

If proper wall outlet is not available, advise the customer to contact qualified electrician for the installation.



- Plug the power cord into the dedicated wall outlet with a capacity greater than the maximum power consumption.

If excessive current flows in the wall outlet, fire may result. 

- If two or more power cords can be plugged into the wall outlet, the total load must not exceed the rating of the wall outlet.

If excessive current flows in the wall outlet, fire may result. 

- Make sure the power cord is plugged in the wall outlet securely.

Contact problems may lead to increased resistance, overheating, and the risk of fire. 

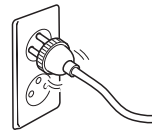

- Check whether the product is grounded properly.  
If current leakage occurs in an ungrounded product, you may suffer electric shock while operating the product.  
Connect power plug to grounded wall outlet. 

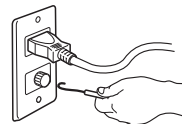

## Power Plug and Cord

### ⚠ WARNING

- When using the power cord set (inlet type) that came with this product, make sure the connector is securely inserted in the inlet of the product.

When securing measure is provided, secure the cord with the fixture properly.

If the power cord (inlet type) is not connected to the product securely, a contact problem may lead to increased resistance, overheating, and risk of fire.

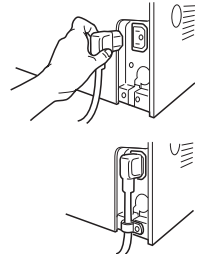

- Check whether the power cord is not stepped on or pinched by a table and so on.

Overheating may occur there, leading to a risk of fire.

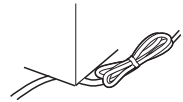

- Check whether the power cord is damaged. Check whether the sheath is damaged.

If the power plug, cord, or sheath is damaged, replace with a new power cord (with plug and connector on each end) specified by KMBT. Using the damaged power cord may result in fire or electric shock.

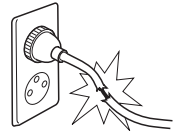

- Do not bundle or tie the power cord.

Overheating may occur there, leading to a risk of fire.

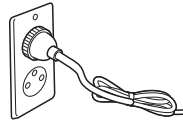

- Check whether dust is collected around the power plug and wall outlet.

Using the power plug and wall outlet without removing dust may result in fire.

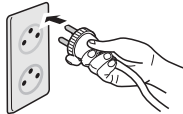

- Do not insert the power plug into the wall outlet with a wet hand.

The risk of electric shock exists.



- When unplugging the power cord, grasp the plug, not the cable.

The cable may be broken, leading to a risk of fire and electric shock.





## Wiring

### WARNING

- Never use multi-plug adapters to plug multiple power cords in the same outlet.

If used, the risk of fire exists.

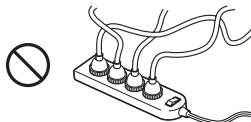

- When an extension cord is required, use a specified one. Current that can flow in the extension cord is limited, so using a too long extension cord may result in fire.

Do not use an extension cable reel with the cable taken up. Fire may result.



## 2. Installation Requirements

### Prohibited Installation Places

#### WARNING

- Do not place the product near flammable materials or volatile materials that may catch fire.

A risk of fire exists.



- Do not place the product in a place exposed to water such as rain.

A risk of fire and electric shock exists.

### When not Using the Product for a long time

#### WARNING

- When the product is not used over an extended period of time (holidays, etc.), switch it off and unplug the power cord.

Dust collected around the power plug and outlet may cause fire.

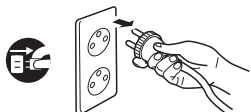

## Ventilation

### ⚠ CAUTION

- The product generates ozone gas during operation, but it will not be harmful to the human body.

If a bad smell of ozone is present in the following cases, ventilate the room.

- a. When the product is used in a poorly ventilated room
- b. When taking a lot of copies
- c. When using multiple products at the same time



## Stability

### ⚠ CAUTION

- Be sure to lock the caster stoppers.

In the case of an earthquake and so on, the product may slide, leading to a injury.



## Inspection before Servicing

### ⚠ CAUTION

- Before conducting an inspection, read all relevant documentation (service manual, technical notices, etc.) and proceed with the inspection following the prescribed procedure in safety clothes, using only the prescribed tools. Do not make any adjustment not described in the documentation.

If the prescribed procedure or tool is not used, the product may break and a risk of injury or fire exists.

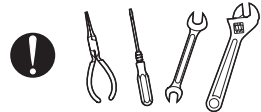

- Before conducting an inspection, be sure to disconnect the power plugs from the product and options.

When the power plug is inserted in the wall outlet, some units are still powered even if the POWER switch is turned OFF. A risk of electric shock exists.

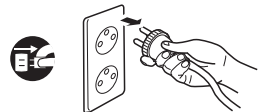

- The area around the fixing unit is hot.

You may get burnt.

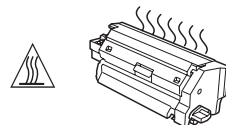

## Work Performed with the Product Powered On

### WARNING

- Take every care when making adjustments or performing an operation check with the product powered.

If you make adjustments or perform an operation check with the external cover detached, you may touch live or high-voltage parts or you may be caught in moving gears or the timing belt, leading to a risk of injury.

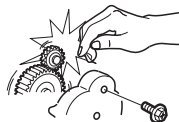

- Take every care when servicing with the external cover detached.

High-voltage exists around the drum unit. A risk of electric shock exists.



## Safety Checkpoints

### WARNING

- Check the exterior and frame for edges, burrs, and other damage.

The user or CE may be injured.



- Do not allow any metal parts such as clips, staples, and screws to fall into the product.

They can short internal circuits and cause electric shock or fire.

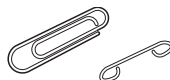

- Check wiring for squeezing and any other damage.

Current can leak, leading to a risk of electric shock or fire.



- Carefully remove all toner remnants and dust from electrical parts and electrode units such as a charging corona unit.

Current can leak, leading to a risk of product trouble or fire.



- Check high-voltage cables and sheaths for any damage.

Current can leak, leading to a risk of electric shock or fire.



## Safety Checkpoints

### WARNING

- Check electrode units such as a charging corona unit for deterioration and sign of leakage.

Current can leak, leading to a risk of trouble or fire.



- Before disassembling or adjusting the write unit (P/H unit) incorporating a laser, make sure that the power cord has been disconnected.

The laser light can enter your eye, leading to a risk of loss of eyesight.



- Do not remove the cover of the write unit. Do not supply power with the write unit shifted from the specified mounting position.

The laser light can enter your eye, leading to a risk of loss of eyesight.



- When replacing a lithium battery, replace it with a new lithium battery specified in the Parts Guide Manual. Dispose of the used lithium battery using the method specified by local authority.

Improper replacement can cause explosion.



- After replacing a part to which AC voltage is applied (e.g., optical lamp and fixing lamp), be sure to check the installation state.

A risk of fire exists.

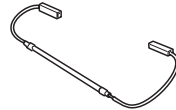

- Check the interlock switch and actuator for loosening and check whether the interlock functions properly.

If the interlock does not function, you may receive an electric shock or be injured when you insert your hand in the product (e.g., for clearing paper jam).

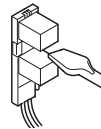

- Make sure the wiring cannot come into contact with sharp edges, burrs, or other pointed parts.

Current can leak, leading to a risk of electric shock or fire.



## Safety Checkpoints

### WARNING

- Make sure that all screws, components, wiring, connectors, etc. that were removed for safety check and maintenance have been reinstalled in the original location. (Pay special attention to forgotten connectors, pinched cables, forgotten screws, etc.)



A risk of product trouble, electric shock, and fire exists.

## Handling of Consumables

### WARNING

- Toner and developer are not harmful substances, but care must be taken not to breathe excessive amounts or let the substances come into contact with eyes, etc. It may be stimulative.

If the substances get in the eye, rinse with plenty of water immediately. When symptoms are noticeable, consult a physician.



- Never throw the used cartridge and toner into fire. You may be burned due to dust explosion.



## Handling of Service Materials

### CAUTION

- Unplug the power cord from the wall outlet. Drum cleaner (isopropyl alcohol) and roller cleaner (acetone-based) are highly flammable and must be handled with care. A risk of fire exists.

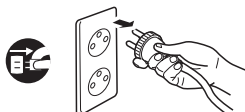

- Do not replace the cover or turn the product ON before any solvent remnants on the cleaned parts have fully evaporated.



A risk of fire exists.

## Handling of Service Materials

### CAUTION

- Use only a small amount of cleaner at a time and take care not to spill any liquid. If this happens, immediately wipe it off.  
A risk of fire exists.



- When using any solvent, ventilate the room well.  
Breathing large quantities of organic solvents can lead to discomfort.

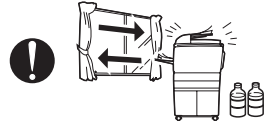

## [4] Used Batteries Precautions

ALL Areas

### CAUTION

Danger of explosion if battery is incorrectly replaced.

Replace only with the same or equivalent type recommended by the manufacturer.

Dispose of used batteries according to the manufacturer's instructions.

Germany

### VORSICHT!

Explosionsgefahr bei unsachgemäßem Austausch der Batterie.

Ersatz nur durch denselben oder einen vom Hersteller empfohlenen gleichwertigen Typ.

Entsorgung gebrauchter Batterien nach Angaben des Herstellers.

France

### ATTENTION

Il y a danger d'explosion s'il y a remplacement incorrect de la batterie.

Remplacer uniquement avec une batterie du même type ou d'un type équivalent recommandé par le constructeur.

Mettre au rebut les batteries usagées conformément aux instructions du fabricant.

Denmark

### ADVARSEL!

Lithiumbatteri - Eksplosionsfare ved fejlagtig håndtering.

Udskiftning må kun ske med batteri af samme fabrikat og type.

Levér det brugte batteri tilbage til leverandøren.

Finland, Sweden

### VAROITUS

Paristo voi räjähtää, jos se on virheellisesti asennettu.

Vaihda paristo ainoastaan laitevalmistajan suosittelemaan tyyppiin.

Hävittä käytetty paristo valmistajan ohjeiden mukaisesti.

### VARNING

Explosionsfara vid felaktigt batteribyte.

Använd samma batterityp eller en ekvivalent typ som rekommenderas av apparattillverkaren.

Kassera använt batteri enligt fabrikantens instruktion.

Norway

### ADVARSEL

Eksplosjonsfare ved feilaktig skifte av batteri.

Benytt samme batteritype eller en tilsvarende type anbefalt av apparatfabrikanten.

Brukte batterier kasseres i henhold til fabrikantens instruksjoner.

## [5] Laser Safety

- This is a digital machine certified as a Class 1 laser product. There is no possibility of danger from a laser, provided the machine is serviced according to the instruction in this manual.

### 5.1 Internal Laser Radiation

semiconductor laser		
Maximum power of the laser diode		30 mW
Maximum average radiation power (*)	bizhub C353	11.6 $\mu$ W
	bizhub C253/C203	7.7 $\mu$ W
Wavelength		775-800 nm

\*at laser aperture of the print head unit

- This product employs a Class 3B laser diode that emits an invisible laser beam. The laser diode and the scanning polygon mirror are incorporated in the print head unit.
- The print head unit is **NOT A FIELD SERVICEABLE ITEM**. Therefore, the print head unit should not be opened under any circumstances.

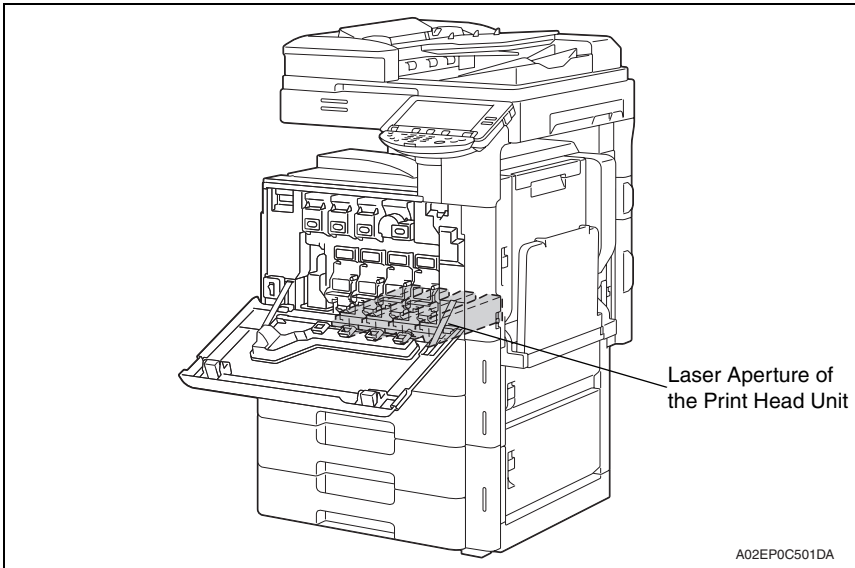



**U.S.A., Canada  
(CDRH Regulation)**

- This machine is certified as a Class 1 Laser product under Radiation Performance Standard according to the Food, Drug and Cosmetic Act of 1990. Compliance is mandatory for Laser products marketed in the United States and is reported to the Center for Devices and Radiological Health (CDRH) of the U.S. Food and Drug Administration of the U.S. Department of Health and Human Services (DHHS). This means that the device does not produce hazardous laser radiation.
- The label shown on page S-16 indicates compliance with the CDRH regulations and must be attached to laser products marketed in the United States.

**CAUTION**

- **Use of controls, adjustments or performance of procedures other than those specified in this manual may result in hazardous radiation exposure.**

semiconductor laser	
Maximum power of the laser diode	30 mW
Wavelength	775-800 nm

**All Areas**

**CAUTION**

- **Use of controls, adjustments or performance of procedures other than those specified in this manual may result in hazardous radiation exposure.**

semiconductor laser	
Maximum power of the laser diode	30 mW
Wavelength	775-800 nm

**Denmark**

**ADVARSEL**

- **Usynlig laserstråling ved åbning, når sikkerhedsafbrydere er ude af funktion. Undgå udsættelse for stråling. Klasse 1 laser produkt der opfylder IEC60825-1 sikkerheds kravene.**

halvlederlaser	
Laserdiodens højeste styrke	30 mW
bølgelængden	775-800 nm

## Finland, Sweden

**LUOKAN 1 LASERLAITE**  
**KLASS 1 LASER APPARAT**
**VAROITUS!**

- Laitteen käyttäminen muulla kuin tässä käyttöohjeessa mainitulla tavalla saattaa altistaa käyttäjän turvallisuusluokan 1 ylittävälle näkymättömälle laser-säteilylle.

puolijohdelaser	
Laserdiodin suurin teho	30 mW
aallonpituus	775-800 nm

**WARNING!**

- Om apparaten används på annat sätt än i denna bruksanvisning specificerats, kan användaren utsättas för osynlig laserstrålning, som överskrider gränsen för laserklass 1.

halvledarlasert	
Den maximala effekten för laserdioden	30 mW
våglängden	775-800 nm

**VARO!**

- Avattaessa ja suojalukitus ohitettaessa olet alttiina näkymättömälle laser-säteilylle. Älä katso säteeseen.

**WARNING!**

- Osynlig laserstrålning när denna del är öppnad och spärren är urkopplad. Betrakta ej strålen.

## Norway

**ADVERSEL**

- Dersom apparatet brukes på annen måte enn spesifisert i denne bruksanvisning, kan brukeren utsettes for usynlig laserstrålning, som overskrider grensen for laser klass 1.

halvleder laser	
Maksimal effekt till laserdioden	30 mW
bølgelengde	775-800 nm

### 5.2 Laser Safety Label

- A laser safety label is attached to the inside of the machine as shown below.

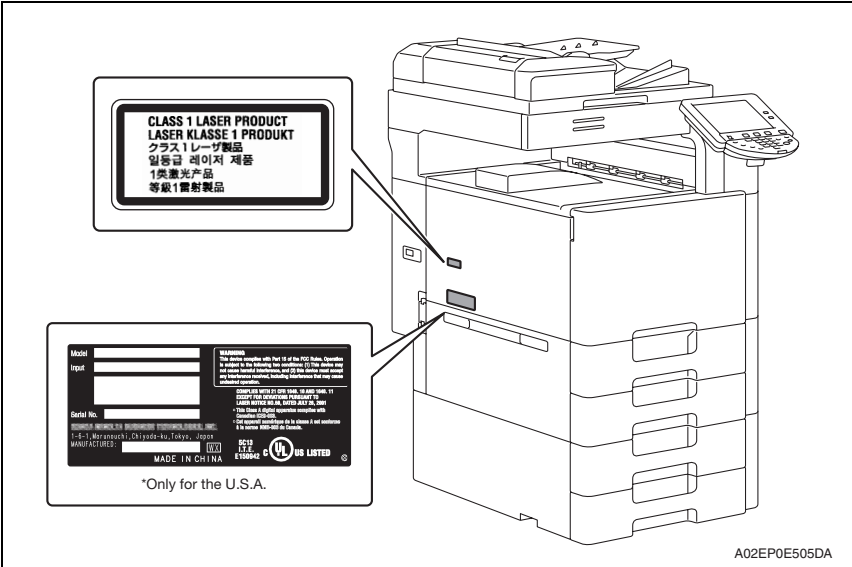

### 5.3 Laser Caution Label

- A laser caution label is attached to the outside of the machine as shown below.

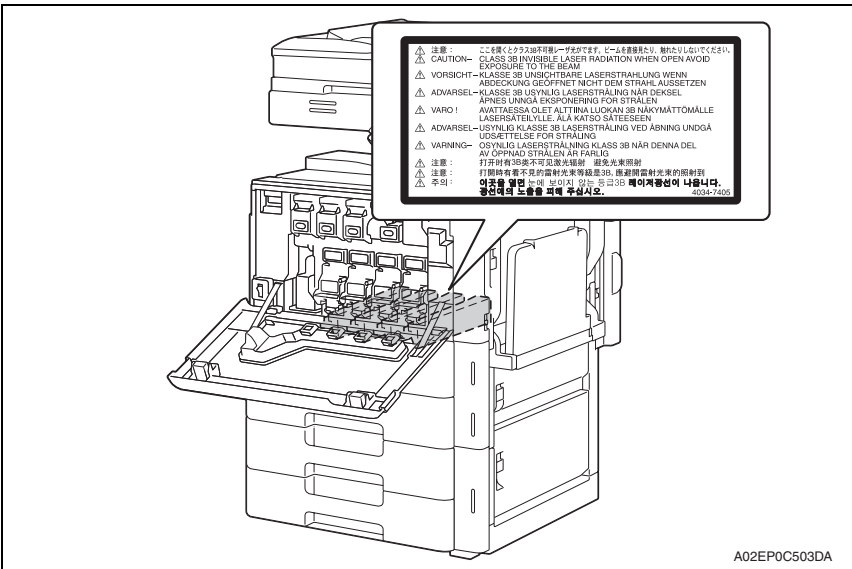

## **5.4 PRECAUTIONS FOR HANDLING THE LASER EQUIPMENT**

- When laser protective goggles are to be used, select ones with a lens conforming to the above specifications.
- When a disassembly job needs to be performed in the laser beam path, such as when working around the printerhead and PC drum, be sure first to turn the printer OFF.
- If the job requires that the printer be left ON, take off your watch and ring and wear laser protective goggles.
- A highly reflective tool can be dangerous if it is brought into the laser beam path. Use utmost care when handling tools on the user's premises.
- The Print head is not to be disassembled or adjusted in the field. Replace the unit or Assembly including the control board. Therefore, remove the laser diode, and do not perform control board trimmer adjustment.

# WARNING INDICATIONS ON THE MACHINE

Caution labels shown are attached in some areas on/in the machine.  
 When accessing these areas for maintenance, repair, or adjustment, special care should be taken to avoid burns and electric shock.

**CAUTION**

The area around the fusing unit is extremely hot.  
 Touching any part other than those indicated may result in burns.

**TONER** Net Wt. 860g (30.4oz)  
 BLACK / SCHWARZ Toner made in Japan  
 NOIR / ブラック Asssembled in China  
 sPSC Label A207155101

⚠ **WARNING** ⚠ **ATTENTION**  
 ⚠ **ATENCIÓN** ⚠ **警告**  
 ⚠ **AVISO** ⚠ **경고**  
 ⚠ **AVISO** ⚠ **注意**

⚠ **WARNING**

Do not burn used toner cartridges. Toner expelled from the fire is dangerous.

⚠ **CAUTION** ⚠ **ATTENTION** ⚠ **PRECAUCIÓN** ⚠ **注意** ⚠ **注意**  
 High temperature! Temperature élevée! Temperature élevée! 高温! 高温!  
 ⚠ **VORSICHT** ⚠ **CUIDADO** ⚠ **ATTENZIONE** ⚠ **주의** ⚠ **注意**  
 Heiße Oberfläche! Alta temperatura! Alta temperatura! 고온! 고온!



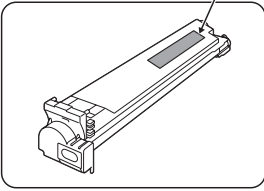

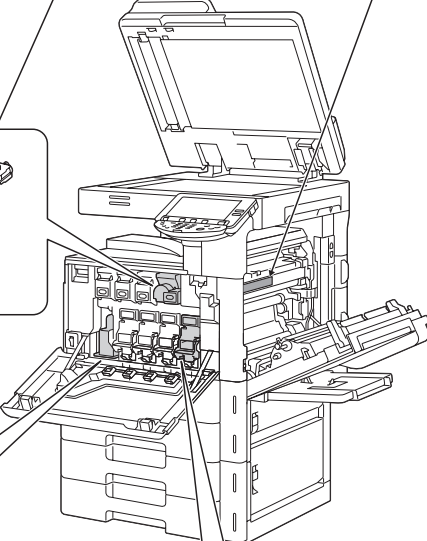

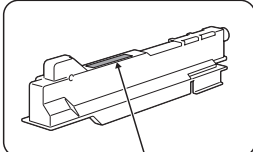



⚠ **WARNING** ⚠ **ATENCIÓN** ⚠ **警告**  
 ⚠ **ATTENTION** ⚠ **AVISO** ⚠ **경고**  
 ⚠ **WARNING** ⚠ **AVISO** ⚠ **注意**

⚠ **WARNING**

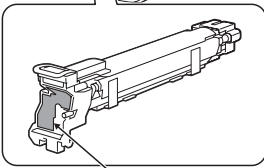
Do not position the used waste toner box so that it is standing on end or tilted, otherwise toner may spill.





**CAUTION**

Do not burn the used waste toner box.  
 Toner expelled from the from the fire is dangerous.



**WARNING**

Do not burn used Imaging Units.  
 Toner expelled from the fire is dangerous.

A02EP0E506DA



**CAUTION:**

- You may be burned or injured if you touch any area that you are advised not to touch by any caution label. Do not remove caution labels. If any caution label has come off or soiled and therefore the caution cannot be read, contact our service office.

## **MEASURES TO TAKE IN CASE OF AN ACCIDENT**

1. If an accident has occurred, the distributor who has been notified first must immediately take emergency measures to provide relief to affected persons and to prevent further damage.
2. If a report of a serious accident has been received from a customer, an on-site evaluation must be carried out quickly and KMBT must be notified.
3. To determine the cause of the accident, conditions and materials must be recorded through direct on-site checks, in accordance with instructions issued by KMBT.
4. For reports and measures concerning serious accidents, follow the regulations specified by every distributor.

# Composition of the service manual

This service manual consists of Theory of Operation section and Field Service section to explain the main machine and its corresponding options.

Theory of Operation section gives, as information for the CE to get a full understanding of the product, a rough outline of the object and role of each function, the relationship between the electrical system and the mechanical system, and the timing of operation of each part.

Field Service section gives, as information required by the CE at the site (or at the customer's premise), a rough outline of the service schedule and its details, maintenance steps, the object and role of each adjustment, error codes and supplementary information.

The basic configuration of each section is as follows. However some options may not be applied to the following configuration.

## <Theory of Operation section>

OUTLINE:	Explanation of system configuration, product specifications, unit configuration, and paper path
COMPOSITION/OPERATION:	Explanation of configuration of each unit, operating system, and control system

## <Field Service section>

GENERAL:	Explanation of system configuration, and product specifications
MAINTENANCE:	Explanation of service schedule, maintenance steps, service tools, removal/reinstallation methods of major parts, and firmware version up method etc.
ADJUSTMENT/SETTING:	Explanation of utility mode, service mode, and mechanical adjustment etc.
TROUBLESHOOTING:	Explanation of lists of jam codes and error codes, and their countermeasures etc.
APPENDIX:	Parts layout drawings, connector layout drawings, timing chart, overall layout drawing are attached.



# Notation of the service manual

## A. Product name

In this manual, each of the products is described as follows:

- |                               |                              |
|-------------------------------|------------------------------|
| (1) bizhub C353/C253/C203:    | Main body                    |
| (2) Microsoft Windows NT 4.0: | Windows NT 4.0 or Windows NT |
| Microsoft Windows 2000:       | Windows 2000                 |
| Microsoft Windows XP:         | Windows XP                   |
| Microsoft Windows Vista:      | Windows Vista                |

When the description is made in combination of the OS's mentioned above:

Windows 98/Me  
Windows NT 4.0/2000  
Windows NT/2000/XP/Vista

## B. Brand name

The company names and product names mentioned in this manual are the brand name or the registered trademark of each company.

## C. Feeding direction

- When the long side of the paper is parallel with the feeding direction, it is called short edge feeding. The feeding direction which is perpendicular to the short edge feeding is called the long edge feeding.
- Short edge feeding will be identified with [S (abbreviation for Short edge feeding)] on the paper size. No specific notation is added for the long edge feeding.

When the size has only the short edge feeding with no long edge feeding, [S] will not be added to the paper size.

<Sample notation>

Paper size	Feeding direction	Notation
A4	Long edge feeding	A4
	Short edge feeding	A4S
A3	Short edge feeding	A3



KONICA MINOLTA

**SERVICE MANUAL**

FIELD SERVICE

---

# **bizhub**

## **C353/C253/C203**

### **Main body**





# Revision history

After publication of this service manual, the parts and mechanism may be subject to change for improvement of their performance.

Therefore, the descriptions given in this service manual may not coincide with the actual machine.

When any change has been made to the descriptions in the service manual, a revised version will be issued with a revision mark added as required.



Revision mark:

- To indicate clearly a specific section revised within text,  is shown at the left margin of the corresponding revised section.  
The number inside  represents the number of times the revision has been made.
- To indicate clearly a specific page that contains a revision or revisions, the page number appearing at the left or right bottom of the specific page is marked with .  
The number inside  represents the number of times the revision has been made.

## NOTE

Revision marks shown in a page are restricted only to the latest ones with the old ones deleted.

- When a page revised in Ver. 2.0 has been changed in Ver. 3.0:  
The revision marks for Ver. 3.0 only are shown with those for Ver. 2.0 deleted.
- When a page revised in Ver. 2.0 has not been changed in Ver. 3.0:  
The revision marks for Ver. 2.0 are left as they are.

2008/01	3.0		Description addition of function enhanced version 2 firmware (Card Ver. 88)/Error corrections
2007/11	2.0		Description addition of function enhanced version 1, error corrections
2007/07	1.0	—	Issue of the first edition
Date	Service manual Ver.	Revision mark	Descriptions of revision

# CONTENTS

## bizhub C353/C253/C203 Main body

### General

1.	System configuration.....	1
2.	Product specifications .....	3

### Maintenance

3.	Periodical check .....	11
3.1	Service schedule .....	11
3.1.1	Main body .....	11
3.1.2	Options.....	12
3.2	Maintenance items.....	13
3.2.1	Main body .....	13
3.2.2	DF-611 .....	15
3.2.3	PC-104/204/405.....	15
3.2.4	FS-519 .....	16
3.2.5	FS-609 .....	16
3.3	Maintenance parts.....	17
3.3.1	Replacement parts.....	17
3.3.2	Cleaning parts.....	19
3.4	Concept of parts life.....	20
3.4.1	Life value of consumables and parts.....	20
3.4.2	Conditions for life specifications values.....	21
3.4.3	Control causing inhibited printing for one part when an inhibited-printing event occurs in another part.....	21
3.5	Maintenance procedure (periodical check parts).....	22
3.5.1	Cleaning of the electrostatic charger wire.....	22
3.5.2	Cleaning of the timing roller .....	22
3.5.3	Cleaning of the area around the waste toner collecting port.....	23
3.5.4	Cleaning of the duplex transport rollers .....	23
3.5.5	Replacing the tray 1 feed roller/tray 1 pick-up roller.....	24
3.5.6	Replacing the tray 1 separation roller assy .....	27
3.5.7	Replacing the tray 2 feed roller/tray 2 pick-up roller .....	28
3.5.8	Replacing the tray 2 separation roller assy .....	31
3.5.9	Replacing the manual bypass tray feed roller .....	32
3.5.10	Replacing the manual bypass tray separation roller assy.....	34

	3.5.11	Replacing the waste toner box.....	35
	3.5.12	Replacing the transfer roller unit.....	36
	3.5.13	Replacing the imaging unit .....	37
	3.5.14	Replacing the ozone filter .....	41
	3.5.15	Replacing the toner cartridge .....	41
	3.5.16	Replacing the transfer belt unit.....	43
	3.5.17	Cleaning of the image transfer entrance guide.....	45
	3.5.18	Cleaning of the IDC/registration sensor/MK, YC .....	45
	3.5.19	Replacing the fusing unit .....	46
4.		Service tool .....	48
4.1		Service material list.....	48
4.2		CE tool list .....	48
4.3		Copy materials .....	49
4.3.1		Imaging unit single parts (IU).....	49
4.3.2		Toner cartridge single parts (T/C) .....	49
4.3.3		Waste toner box.....	49
4.3.4		Maintenance kit.....	49
5.		Firmware upgrade.....	50
5.1		Outline .....	50
5.2		Notes about firmware rewrite .....	50
5.2.1		Types of firmware.....	50
5.2.2		Rewrite to/from a function enhanced version of firmware.....	50
5.3		Preparations for firmware rewriting by Windows Command Prompt .....	51
5.3.1		Service environment.....	51
5.3.2		Writing into the compact flash.....	51
5.4		Preparations for firmware rewriting by Firmware Imaging Toolkit 2006.....	54
5.4.1		Correspond model .....	54
5.4.2		Function outline .....	54
5.4.3		System environment .....	54
5.4.4		Installation of software .....	55
5.4.5		Update of software.....	57
5.4.6		Screen .....	58
5.4.7		Details of each function .....	60
5.4.8		How to write firmware data .....	62
5.5		Firmware rewriting by compact flash .....	67
5.5.1		Updating method .....	67
5.5.2		Action when data transfer fails.....	69
5.6		Updating the firmware with the Internet ISW.....	70

5.6.1	Outline .....	70
5.6.2	Service environment .....	70
5.6.3	Preparations for firmware rewriting .....	70
5.6.4	Firmware rewriting .....	73
5.6.5	Error code list for the Internet ISW .....	75
6.	Other .....	78
6.1	Disassembly/adjustment prohibited items .....	78
6.2	Disassembly/assembly/cleaning list (other parts) .....	79
6.2.1	Disassembly/assembly parts list .....	79
6.2.2	Cleaning parts list .....	81
6.3	Disassembly/assembly procedure .....	82
6.3.1	Front door .....	82
6.3.2	Upper front cover/1 .....	83
6.3.3	Upper front cover/2 .....	84
6.3.4	Right front cover/1 .....	84
6.3.5	Right front cover/2 .....	85
6.3.6	Left cover .....	86
6.3.7	Rear left cover/1 .....	87
6.3.8	Rear left cover/2 .....	87
6.3.9	Exit cover .....	88
6.3.10	Paper exit rear cover .....	88
6.3.11	IR rear cover, IR right cover, IR upper rear cover/1, IR upper rear cover/2, IR upper rear cover/3 .....	89
6.3.12	IR left cover, IR upper front cover .....	89
6.3.13	IR front cover .....	90
6.3.14	Original glass .....	90
6.3.15	Rear right cover/1, rear right cover/2, rear right cover/3 .....	91
6.3.16	Manual bypass tray front cover, manual bypass tray rear cover .....	92
6.3.17	Upper rear cover, rear cover/1, rear cover/2 .....	92
6.3.18	Lower rear cover/1, lower rear cover/2 .....	93
6.3.19	Vertical transport door .....	93
6.3.20	Control panel assy (UN201) .....	93
6.3.21	Exit tray .....	94
6.3.22	Tray 1 .....	95
6.3.23	Tray 2 .....	95
6.3.24	Front cover .....	96
6.3.25	PH unit .....	98
6.3.26	Manual bypass tray unit .....	103

6.3.27	CCD unit .....	104
6.3.28	Original glass moving unit.....	106
6.3.29	Glass step sheet.....	109
6.3.30	Scanner assy.....	111
6.3.31	Hard disk drive (HDD).....	113
6.3.32	Main drive unit .....	113
6.3.33	Transport drive unit .....	115
6.3.34	Fusing drive unit .....	119
6.3.35	Hopper drive unit (C/K, Y/M).....	121
6.3.36	Right door assy.....	122
6.3.37	IR Assy .....	125
6.3.38	Scanner relay board (REYB/SCAN) .....	127
6.3.39	Original glass position control board (OGPCB) .....	128
6.3.40	Inverter board (INVB).....	129
6.3.41	Image processing board (IPB).....	130
6.3.42	PH relay board (REYB/PH).....	132
6.3.43	DC power supply (DCPU).....	134
6.3.44	Printer control board (PRCB).....	136
6.3.45	MFP board (MFPB).....	138
6.3.46	PWB box.....	139
6.3.47	High voltage unit (HV).....	142
6.3.48	Service EEPROM board (SV ERB) .....	143
6.3.49	SODIMM/1, SODIMM/2 .....	145
6.3.50	JMP board (JMPB) .....	145
6.3.51	NVRAM board (NRB).....	146
6.3.52	Machine condition monitor board (MCMB) .....	146
6.3.53	Paper feed tray 1 paper FD size detect board (PSDTB/1).....	147
6.3.54	Paper feed tray 2 paper FD size detect board (PSDTB/2).....	148
6.3.55	Scanner motor (M201).....	149
6.3.56	Original glass moving motor (M202).....	152
6.3.57	Duplex transport motor (M7).....	153
6.3.58	Transport motor (M1) .....	154
6.3.59	Color PC motor (M2).....	154
6.3.60	Fusing motor (M5) .....	155
6.3.61	Switchback motor (M6).....	156
6.3.62	Fusing retraction motor (M12) .....	157
6.3.63	Paper feed tray 1 lift-up motor (M8) .....	158

6.3.64	Paper feed tray 2 lift-up motor (M9) .....	159
6.3.65	Toner supply motor/CK (M3) .....	161
6.3.66	Toner supply motor/YM (M4) .....	161
6.3.67	Paper feed tray 1 paper feed clutch (CL1) .....	162
6.3.68	Paper feed tray 2 vertical transport clutch (CL3) .....	163
6.3.69	Paper feed tray 2 paper feed clutch (CL2) .....	164
6.3.70	Manual paper feed clutch (CL4) .....	164
6.3.71	Transfer belt retraction clutch (CL7) .....	165
6.3.72	Developing clutch/K (CL5) .....	165
6.3.73	Tim. roller clutch (CL6) .....	166
6.3.74	IDC registration sensor/MK (IDCS/MK), IDC registration sensor/YC (IDCS/YC) .....	167
6.3.75	Scanner drive cables .....	169
6.4	Cleaning procedure .....	180
6.4.1	Transfer belt unit .....	180
6.4.2	PH window Y,M,C,K .....	180
6.4.3	Tray 1 feed roller, tray 1 pick-up roller, tray 1 separation roller .....	181
6.4.4	Tray 2 feed roller, tray 2 pick-up roller, tray 2 separation roller .....	182
6.4.5	Tray 2 transport roller .....	183
6.4.6	Manual bypass tray feed roller .....	183
6.4.7	Manual bypass tray separation roller .....	183
6.4.8	Original glass .....	184
6.4.9	Scanner rails .....	184
6.4.10	Mirrors (1st/2nd/3rd) .....	185
6.4.11	Lens .....	185
6.4.12	CCD sensor .....	186
6.5	Mount the original size detection 2 sensor (PS205) .....	187
6.6	Option counter .....	189
6.6.1	Installation method for the key counter .....	189

## Adjustment/Setting

7.	How to use the adjustment section .....	191
8.	Utility Mode .....	192
8.1	Touch Panel Adjustment .....	192
8.2	Utility Mode function tree .....	193
8.3	Utility Mode function setting procedure .....	203
8.3.1	Procedure .....	203
8.3.2	Exiting .....	203



8.3.3	Changing the setting value in Utility Mode functions .....	203
8.4	One-Touch User Box Registration .....	204
8.4.1	Create One-Touch destination .....	204
8.4.2	Create User Box .....	206
8.4.3	Limiting Access to Destinations .....	207
8.5	User Settings .....	208
8.5.1	System Settings .....	208
8.5.2	Custom Display Settings .....	212
8.5.3	Copier Settings .....	215
8.5.4	Scan/Fax Settings .....	219
8.5.5	Default Scan/Fax Settings .....	220
8.5.6	Default Enlarge Display Settings .....	221
8.5.7	Printer Settings .....	221
8.5.8	Change Password .....	227
8.5.9	Change E-mail Address .....	227
8.6	Administrator Settings .....	228
8.6.1	System Settings .....	228
8.6.2	Administrator/Machine Settings .....	255
8.6.3	One-Touch/User Box Registration .....	256
8.6.4	User Authentication/Account Track .....	260
8.6.5	Network Setting .....	267
8.6.6	Copier Settings .....	302
8.6.7	Printer Settings .....	303
8.6.8	Fax Settings .....	304
8.6.9	System Connection .....	318
8.6.10	Security Settings .....	319
8.6.11	License Settings .....	333
8.7	Banner Printing .....	333
8.8	My Panel Settings .....	334
9.	Adjustment item list .....	336
10.	Service Mode .....	338
10.1	Service Mode function setting procedure .....	338
10.2	Service Mode function tree .....	340
10.3	Date/Time Input mode .....	344
10.3.1	Date & Time Setting mode screen .....	344
10.4	Machine .....	345
10.4.1	Fusing Temperature .....	345
10.4.2	Fusing Transport Speed .....	346

10.4.3	Org. Size Detecting Sensor Adj. ....	346
10.4.4	Printer Area.....	347
10.4.5	Scan Area .....	352
10.4.6	Printer Resist Loop .....	356
10.4.7	Color Registration Adjustment .....	357
10.4.8	Exhaust Fan Stop Delay.....	358
10.4.9	LD adjustment.....	358
10.4.10	Manual Bypass Tray Adjustment.....	360
10.4.11	Lead Edge Erase Adjustment .....	360
10.4.12	Thick Paper Mode .....	360
10.4.13	Split Line Prior Detection .....	361
10.5	Firmware Version.....	361
10.6	Imaging Process Adjustment.....	361
10.6.1	Gradation Adjust .....	361
10.6.2	D Max Density.....	363
10.6.3	TCR Level Setting .....	363
10.6.4	Background Voltage Margin .....	364
10.6.5	Transfer Output Fine Adjustment .....	364
10.6.6	Stabilizer .....	365
10.6.7	Thick Paper Density Adjustment .....	366
10.6.8	TCR Toner Supply.....	366
10.6.9	Monochrome Density Adjustment.....	367
10.6.10	Dev. Bias Choice.....	367
10.7	CS Remote Care .....	368
10.7.1	Outlines.....	368
10.7.2	Setting up the CS Remote Care .....	368
10.7.3	Software SW setting for CS Remote Care .....	371
10.7.4	Setup confirmation.....	376
10.7.5	Calling the maintenance .....	376
10.7.6	Calling the center from the administrator .....	377
10.7.7	Checking the transmission log .....	377
10.7.8	Detail on settings .....	377
10.7.9	List of the CS Remote Care error code.....	383
10.7.10	Troubleshooting for CS Remote Care .....	387
10.8	System 1.....	388
10.8.1	Marketing Area.....	388
10.8.2	Tel/Fax Number .....	388
10.8.3	Serial Number.....	389

10.8.4	No Sleep .....	389
10.8.5	Foolscape Size Setting .....	389
10.8.6	Original Size Detection .....	389
10.8.7	Install Date.....	390
10.8.8	Initialization.....	390
10.8.9	Trouble Isolation.....	391
10.8.10	IU Life Setting .....	392
10.8.11	Change Warm Up Time .....	393
10.8.12	Machine State LED Setting.....	394
10.9	System 2 .....	395
10.9.1	HDD.....	395
10.9.2	Image Controller Setting .....	395
10.9.3	Option Board Status .....	396
10.9.4	Consumable Life Reminder .....	396
10.9.5	Unit Change.....	396
10.9.6	Software Switch Setting.....	397
10.9.7	Scan Calibration.....	397
10.9.8	LCT Paper Size Setting .....	397
10.9.9	Line Mag Setting.....	398
10.9.10	Data Capture .....	399
10.9.11	Split Line Detect. Setting .....	401
10.9.12	Stamp .....	402
10.9.13	Network Fax Settings.....	403
10.10	Counter.....	404
10.10.1	Procedure .....	404
10.10.2	Life.....	404
10.10.3	Jam .....	405
10.10.4	Service Call Counter.....	405
10.10.5	Warning .....	405
10.10.6	Maintenance .....	406
10.10.7	Service Total.....	406
10.10.8	Counter of Each Mode.....	406
10.10.9	Service Call History (Data) .....	406
10.10.10	ADF Paper Pages .....	406
10.10.11	Paper Jam History .....	407
10.10.12	Fax Connection Error.....	407
10.10.13	Split Line Counter .....	407
10.11	List Output .....	408

10.11.1	Machine Management List.....	408
10.11.2	Adjustment List .....	408
10.11.3	Parameter List.....	408
10.11.4	Service Parameter .....	408
10.11.5	Protocol Trace .....	408
10.11.6	Fax Setting List .....	408
10.11.7	Fax Analysis List .....	408
10.12	State Confirmation.....	409
10.12.1	Sensor Check.....	409
10.12.2	Sensor check screens.....	410
10.12.3	Sensor check list.....	414
10.12.4	Table Number.....	422
10.12.5	Level History1 .....	422
10.12.6	Level History 2 .....	422
10.12.7	Temp. & Humidity .....	422
10.12.8	CCD Check .....	423
10.12.9	Memory/HDD Adj.....	423
10.12.10	Memory/HDD State.....	426
10.12.11	Color Regist .....	426
10.12.12	IU Lot No.....	426
10.12.13	Adjustment Data List.....	426
10.13	Test Mode .....	427
10.13.1	Procedure for test pattern output .....	427
10.13.2	Gradation Pattern.....	427
10.13.3	Halftone Pattern .....	428
10.13.4	Lattice Pattern.....	428
10.13.5	Solid Pattern.....	429
10.13.6	Color Sample .....	429
10.13.7	8 Color Solid Pattern .....	430
10.13.8	CMM pattern .....	430
10.13.9	Running Mode.....	430
10.13.10	Fax Test.....	431
10.14	ADF .....	431
10.15	FAX.....	431
10.16	Finisher.....	431
10.16.1	CB-FN adjustment .....	431
10.16.2	FN-X3 Adjustment.....	431
10.16.3	Punch option setting .....	431

	10.16.4	Job Separator .....	431
	10.17	Internet ISW .....	432
	10.17.1	Internet ISW Set .....	432
	10.17.2	HTTP Setting .....	432
	10.17.3	FTP Setting.....	433
	10.17.4	Forwarding Access Setting .....	434
	10.17.5	Download.....	435
	11.	Enhanced Security.....	436
	11.1	Enhanced Security function setting procedure.....	436
	11.1.1	Procedure .....	436
	11.1.2	Exiting .....	436
	11.2	Enhanced Security function tree .....	436
	11.3	Settings in the Enhanced Security .....	437
	11.3.1	CE Password .....	437
	11.3.2	Administrator Password .....	437
	11.3.3	Administrator Feature Level.....	438
	11.3.4	CE Authentication .....	438
	11.3.5	IU Life Stop Setting .....	438
	11.3.6	NVRAM Data Backup .....	439
	11.3.7	Operation Ban release time .....	439
	11.3.8	Administrator unlocking.....	439
	12.	Billing Setting .....	440
	12.1	Billing Setting function setting procedure .....	440
	12.1.1	Procedure .....	440
	12.1.2	Exiting .....	440
	12.2	Billing Setting function tree .....	440
	12.3	Settings in the Billing Setting.....	441
	12.3.1	Counter Setting.....	441
	12.3.2	Management Function Choice.....	442
	12.3.3	Coverage Rate Clear .....	449
	13.	Procedure for resetting.....	450
	13.1	Trouble resetting .....	450
	13.2	Contents to be cleared by reset function.....	450
	14.	Mechanical adjustment .....	451
	14.1	Mechanical adjustment of the scanner section .....	451
	14.1.1	Adjustment of the scanner motor belt.....	451
	14.1.2	Focus positioning of the scanner and mirrors unit.....	452
	14.1.3	Scanner position adjustment .....	453

14.1.4	Adjusting the height of the original glass moving unit .....	454
14.1.5	Adjusting the height of the guide support for the original glass moving unit .....	456
14.2	Mechanical adjustment of the paper feed section .....	457
14.2.1	Skew adjustment of the tray 1, 2 .....	457
14.2.2	Centering adjustment of the tray 1, 2 .....	458
14.2.3	Adjustment of the manual bypass tray paper size unit .....	459
14.3	PH unit mechanical adjustment .....	460
14.3.1	Skew adjustment .....	460

## Troubleshooting

15.	Jam display .....	463
15.1	Misfeed display .....	463
15.1.1	Misfeed display resetting procedure .....	467
15.2	Sensor layout .....	468
15.3	Solution .....	469
15.3.1	Initial check items .....	469
15.3.2	Solution when paper curl occurs .....	469
15.3.3	Misfeed at tray 1 feed section .....	470
15.3.4	Misfeed at tray 2 feed section .....	471
15.3.5	Misfeed at manual bypass feed section .....	472
15.3.6	Misfeed at duplex pre-registration section .....	473
15.3.7	Misfeed at tray 2 vertical transport section .....	474
15.3.8	Misfeed at 2nd image transfer section .....	475
15.3.9	Misfeed at exit section .....	476
15.3.10	Misfeed at duplex transport section .....	477
15.3.11	Controller jam .....	478
16.	Malfunction code .....	479
16.1	Alert code .....	479
16.1.1	Alert code list .....	480
16.2	Solution .....	482
16.2.1	S-1: CCD gain adjustment failure .....	482
16.2.2	D-1: Split line detect .....	482
16.2.3	D-2: Read guide trouble .....	482
16.2.4	P-5: IDC sensor (front) failure .....	483
16.2.5	P-28 IDC sensor (rear) failure .....	483
16.2.6	P-6: Cyan imaging unit failure .....	483
16.2.7	P-7: Magenta imaging unit failure .....	483

bizhub C353/C253/C203	16.2.8	P-8: Yellow imaging unit failure .....	483
	16.2.9	P-9: Black imaging unit failure .....	483
	16.2.10	P-21: Color regist test pattern failure .....	484
	16.2.11	P-22: Color regist adjust failure.....	484
	16.2.12	P-27: Secondary transfer ATVC failure .....	484
	16.2.13	P-30: Color PC drive sensor malfunction.....	485
	16.2.14	P-31: Black PC drive sensor malfunction.....	485
	16.3	Trouble code .....	486
	16.3.1	Trouble code list .....	486
	16.4	How to reset .....	515
	16.5	Solution .....	516
	16.5.1	C0202: Tray 1 feeder up/down abnormality .....	516
	16.5.2	C0204: Tray 2 feeder up/down abnormality .....	516
	16.5.3	C0211: Manual feed up/down abnormality .....	517
16.5.4	C0301: Suction fan motor's failure to turn.....	517	
16.5.5	C0351: Paper cooling fan motor's failure to turn.....	518	
16.5.6	C2151: Secondary transfer roller pressure welding alienation .....	518	
16.5.7	C2152: Transfer belt pressure welding alienation .....	519	
16.5.8	C2164: PC charge malfunction.....	519	
16.5.9	C2253: Color PC motor's failure to turn .....	520	
16.5.10	C2254: Color PC motor's turning at abnormal timing .....	520	
16.5.11	C225D: Color dev. unit engagement/disengagement failure.....	520	
16.5.12	C2351: K toner suction fan motor's failure to turn.....	521	
16.5.13	C2451: Release new transfer belt unit.....	521	
16.5.14	C2551: Abnormally low toner density detected cyan TCR sensor.....	522	
16.5.15	C2553: Abnormally low toner density detected magenta TCR sensor .....	522	
16.5.16	C2555: Abnormally low toner density detected yellow TCR sensor .....	522	
16.5.17	C2552: Abnormally high toner density detected cyan TCR sensor .....	522	
16.5.18	C2554: Abnormally high toner density detected magenta TCR sensor....	522	
16.5.19	C2556: Abnormally high toner density detected yellow TCR sensor.....	522	
16.5.20	C2557: Abnormally low toner density detected black TCR sensor .....	523	
16.5.21	C2558: Abnormally high toner density detected black TCR sensor .....	523	
16.5.22	C2559: Cyan TCR sensor adjustment failure .....	524	
16.5.23	C255A: Magenta TCR sensor adjustment failure .....	524	
16.5.24	C255B: Yellow TCR sensor adjustment failure .....	524	
16.5.25	C255C: Black TCR sensor adjustment failure .....	524	
16.5.26	C2650: Main backup media access error .....	525	
16.5.27	C2651: EEPROM access error (IU C) .....	526	

16.5.28	C2652: EEPROM access error (IU M) .....	526
16.5.29	C2653: EEPROM access error (IU Y) .....	526
16.5.30	C2654: EEPROM access error (IU K) .....	526
16.5.31	C2A01: EEPROM access error (TC C) .....	526
16.5.32	C2A02: EEPROM access error (TC M) .....	526
16.5.33	C2A03: EEPROM access error (TC Y) .....	526
16.5.34	C2A04: EEPROM access error (TC K) .....	526
16.5.35	C3101: Fusing roller separation failure .....	527
16.5.36	C3201: Fusing motor failure to turn .....	527
16.5.37	C3202: Fusing motor turning at abnormal timing .....	527
16.5.38	C3303: Fusing cooling fan motor/ 1 failure to turn .....	528
16.5.39	C3302: Fusing cooling fan motor/ 2,3 failure to turn .....	528
16.5.40	C3421: Fusing heaters trouble (heating side) .....	529
16.5.41	C3423: Fusing heaters trouble (pressurizing side) .....	529
16.5.42	C3461: Release new fusing unit .....	529
16.5.43	C3721: Fusing abnormally high temperature detection (heating side) .....	530
16.5.44	C3723: Fusing abnormally high temperature detection (pressurizing side) .....	530
16.5.45	C3821: Fusing abnormally low temperature detection (heating side) .....	530
16.5.46	C3823: Fusing abnormally low temperature detection (pressurizing side) .....	530
16.5.47	C4151: Polygon motor rotation trouble (C) .....	531
16.5.48	C4152: Polygon motor rotation trouble (M) .....	531
16.5.49	C4153: Polygon motor rotation trouble (Y) .....	531
16.5.50	C4154: Polygon motor rotation trouble (K) .....	531
16.5.51	C4551: Laser malfunction (C) .....	531
16.5.52	C4552: Laser malfunction (M) .....	531
16.5.53	C4553: Laser malfunction (Y) .....	531
16.5.54	C4554: Laser malfunction (K) .....	531
16.5.55	C5102: Transport motor's failure to turn .....	532
16.5.56	C5103: Transport motor's turning at abnormal timing .....	532
16.5.57	C5351: Power supply cooling fan motor's failure to turn .....	532
16.5.58	C5353: Cooling fan motor/2's failure to turn .....	533
16.5.59	C5354: Exhaust fan motor's failure to turn .....	533
16.5.60	C5357: Cooling fan motor/1's failure to turn .....	534
16.5.61	C5370: MFP board cooling fan motor's failure to turn .....	534
16.5.62	C5371: MFP board CPU cooling fan motor's failure to turn .....	535
16.5.63	C6102: Drive system home sensor malfunction .....	535
16.5.64	C6103: Slider over running .....	535

bizhub C353/C253/C203

General

Maintenance

Adjustment / Setting

Troubleshooting

Appendix



16.5.65	C6301: Optical cooling fan motor's failure to turn .....	536
16.5.66	C6704: Image input time out.....	536
16.5.67	C6751: CCD clamp/gain adjustment failure.....	537
16.5.68	C6F01: Scanner sequence trouble 1 .....	537
16.5.69	C9401: Exposure turning on the lamp trouble detection.....	538
16.5.70	C9402: Exposure turning on the lamp abnormally detection.....	538
16.5.71	CA051: Standard controller configuration failure .....	538
16.5.72	CA052: Controller hardware error.....	538
16.5.73	CA053: Controller start failure .....	538
16.5.74	CC001: Vendor connection failure .....	539
16.5.75	CC151: ROM contents error upon startup (MSC).....	539
16.5.76	CC152: ROM contents error upon startup (Scanner) .....	539
16.5.77	CC153: ROM contents error upon startup (PRT) .....	539
16.5.78	CC163: ROM contents error (PRT).....	540
16.5.79	CC164: ROM contents error (MSC).....	541
16.5.80	CC170: Dynamic link error during starting (AP0) .....	541
16.5.81	CC171: Dynamic link error during starting (AP1) .....	541
16.5.82	CC172: Dynamic link error during starting (AP2) .....	541
16.5.83	CC173: Dynamic link error during starting (AP3) .....	541
16.5.84	CC174: Dynamic link error during starting (AP4) .....	541
16.5.85	CC180: Dynamic link error during starting (LDR).....	541
16.5.86	CC181: Dynamic link error during starting (IBR) .....	541
16.5.87	CC182: Dynamic link error during starting (IID).....	541
16.5.88	CC183: Dynamic link error during starting (IPF).....	541
16.5.89	CC184: Dynamic link error during starting (IMY).....	541
16.5.90	CD002: JOB RAM save error.....	542
16.5.91	CD004: Hard disk access error.....	542
16.5.92	CD005: Hard disk error 1 .....	542
16.5.93	CD006: Hard disk error 2.....	542
16.5.94	CD007: Hard disk error 3.....	542
16.5.95	CD008: Hard disk error 4.....	542
16.5.96	CD009: Hard disk error 5.....	542
16.5.97	CD00A: Hard disk error 6 .....	542
16.5.98	CD00B: Hard disk error 7 .....	542
16.5.99	CD00C: Hard disk error 8 .....	542
16.5.100	CD00D: Hard disk error 9 .....	542
16.5.101	CD00E: Hard disk error A.....	542

16.5.102	CD00F: Hard disk data transfer error.....	542
16.5.103	CD020: Hard disk verify error.....	542
16.5.104	CD010: Hard disk unformat .....	543
16.5.105	CD011: Hard disk out of specifications mounted .....	543
16.5.106	CD201: File memory mounting error.....	543
16.5.107	CD202: Memory capacity discrepancy .....	543
16.5.108	CD203: Memory capacity discrepancy 2 .....	543
16.5.109	CD211: PCI-SDRAM DMA operation failure .....	544
16.5.110	CD212: Compression/extraction timeout detection .....	544
16.5.111	CD231: No Fax memory at FAX board mounting.....	544
16.5.112	CD241: Encryption board setting error .....	544
16.5.113	CD242: Encryption board mounting error .....	544
16.5.114	CD251: No JPEG board mounting at JPEG board mount setting.....	545
16.5.115	CD261: USB host board failure .....	545
16.5.116	CD271: i-Option activated and additional memory not installed .....	545
16.5.117	CD401: NACK command incorrect .....	546
16.5.118	CD402: ACK command incorrect.....	546
16.5.119	CD403: Checksum error .....	546
16.5.120	CD404: Receiving packet incorrect.....	546
16.5.121	CD405: Receiving packet analysis error .....	546
16.5.122	CD406: ACK receiving timeout .....	546
16.5.123	CD407: Retransmission timeout .....	546
16.5.124	CE001: Abnormal message queue .....	546
16.5.125	CE003: Task error .....	546
16.5.126	CE004: Event error .....	546
16.5.127	CE005: Memory access error .....	546
16.5.128	CE006: Header access error .....	546
16.5.129	CE007: DIMM initialize error .....	546
16.5.130	CD3##: NVRAM data error .....	547
16.5.131	CE002: Message and method parameter failure .....	548
16.5.132	CEEE1: MSC undefined malfunction occurring .....	548
16.5.133	CEEE2: Scanner section undefined malfunction .....	548
16.5.134	CEEE3: Engine section undefined malfunction .....	549
17.	Power supply trouble.....	550
17.1	Machine is not energized at all (DCPU operation check) .....	550
17.2	Control panel indicators do not light. ....	550
17.3	Fusing heaters do not operate.....	551
17.4	Power is not supplied to option .....	551

	17.4.1	DF-611 .....	551
	17.4.2	PC-104/204/405.....	551
	17.4.3	FS-519/JS-505/FS-609.....	552
18.		Image quality problem.....	553
18.1		How to read element date .....	553
18.1.1		Table number .....	554
18.1.2		Level history 1.....	555
18.1.3		Level history 2.....	556
18.2		How to identify problematic part.....	557
18.2.1		Initial check items .....	557
18.3		Solution .....	559
18.3.1		Scanner system: white lines in sub scan direction, white bands in sub scan direction, colored lines in sub scan direction, and colored bands in sub scan direction .....	559
18.3.2		Scanner system: white lines in main scan direction, white bands in main scan direction, colored lines in main scan direction, and colored bands in main scan direction.....	561
18.3.3		Scanner system: color spots.....	562
18.3.4		Scanner system: fog .....	563
18.3.5		Scanner system: blurred image, blotchy image .....	564
18.3.6		Scanner system: incorrect color image registration, sync shift (lines in main scan direction) .....	565
18.3.7		Scanner system: moire .....	566
18.3.8		Scanner system: skewed image .....	567
18.3.9		Scanner system: distorted image .....	568
18.3.10		Scanner system: low image density, rough image.....	569
18.3.11		Scanner system: defective ACS.....	570
18.3.12		Scanner system: blank copy, black copy.....	571
18.3.13		Scanner system: abnormal image .....	572
18.3.14		Scanner system: uneven density .....	573
18.3.15		Printer monochrome: white lines in sub scan direction, white bands in sub scan direction, colored lines colored bands in sub scan direction.....	574
18.3.16		Printer monochrome: white lines in main scan direction, white bands in main scan direction, colored lines in main scan direction, colored bands in main scan direction.....	575
18.3.17		Printer monochrome: uneven density in sub scan direction .....	576
18.3.18		Printer monochrome: uneven density in main scan direction .....	577
18.3.19		Printer monochrome: low image density.....	578
18.3.20		Printer monochrome: gradation reproduction failure.....	580
18.3.21		Printer monochrome: foggy background .....	581

18.3.22	Printer monochrome: void areas, white spots .....	583
18.3.23	Printer monochrome: colored spots .....	584
18.3.24	Printer monochrome: blurred image.....	585
18.3.25	Printer monochrome: blank copy, black copy .....	586
18.3.26	Printer monochrome: uneven image .....	587
18.3.27	Printer 4-color: white lines in sub scan direction, white bands in sub scan direction, colored lines in sub scan direction, and colored bands in sub scan direction .....	588
18.3.28	Printer 4-color: white lines in main scan direction, white bands in main scan direction, colored lines in main scan direction, and colored bands in main scan direction .....	589
18.3.29	Printer 4-color: uneven density in sub scan direction.....	590
18.3.30	Printer 4-color: uneven density in main scan direction.....	591
18.3.31	Printer 4-color: low image density.....	592
18.3.32	Printer 4-color: poor color reproduction .....	593
18.3.33	Printer 4-color: incorrect color image registration .....	594
18.3.34	Printer 4-color: void areas, white spots .....	595
18.3.35	Printer 4-color: colored spots .....	596
18.3.36	Printer 4-color: poor fusing performance, offset.....	597
18.3.37	Printer 4-color: brush effect, blurred image.....	598
18.3.38	Printer 4-color: back marking .....	599
18.3.39	Printer 4-color: uneven image .....	600

## Appendix

19.	Parts layout drawing .....	601
19.1	Main body .....	601
19.1.1	Scanner section .....	601
19.1.2	Engine section .....	602
19.1.3	Tray 1, manual bypass tray .....	606
19.1.4	Tray 2 .....	607
19.2	DF-611 (option).....	608
19.3	PC-104/204 (option) .....	610
19.4	PC-405 (option) .....	611
19.5	FS-519 (option).....	612
19.6	PK-515 (option).....	615
19.7	MT-502 (option).....	616
19.8	SD-505 (option) .....	617
19.9	JS-505 (option) .....	618
19.10	FS-609 (option).....	619

19.11 PK-501 (option) ..... 622

20. Connector layout drawing ..... 623

21. Timing chart ..... 626

21.1 Main body ..... 626

21.2 DF-611 ..... 627

21.2.1 1-sided mode ..... 627

21.2.2 2-sided mode ..... 628

# General

## 1. System configuration

1/2 System front view

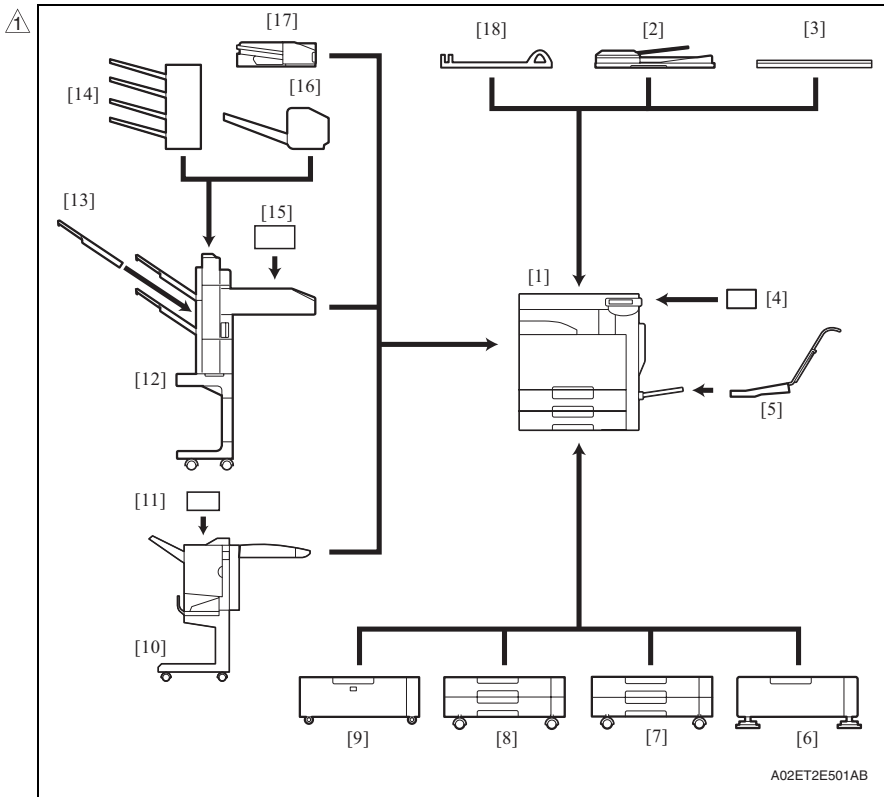

- |   |                      |           |
|---|----------------------|-----------|
| ⚠ [1] Main body                                   | [10] Finisher        | FS-609    |
| ⚠ [2] Reverse Automatic document feeder<br>DF-611 | [11] Punch kit       | PK-501    |
| [3] Original cover                                | [12] Finisher        | FS-519    |
| [4] Key counter kit                               | [13] Output tray     | OT-602    |
| [5] Mount kit                                     | [14] Mailbin kit     | MT-502    |
| [6] Desk  | [15] Punch kit       | PK-515    |
| [7] Paper feed cabinet                            | [16] Saddle stitcher | SD-505    |
| [8] Paper feed cabinet                            | [17] Job separator   | JS-505    |
| [9] Paper feed cabinet                            | [18] Assist handle   | AH-101 *1 |

\*1: Option of OC-507

2/2 System rear view

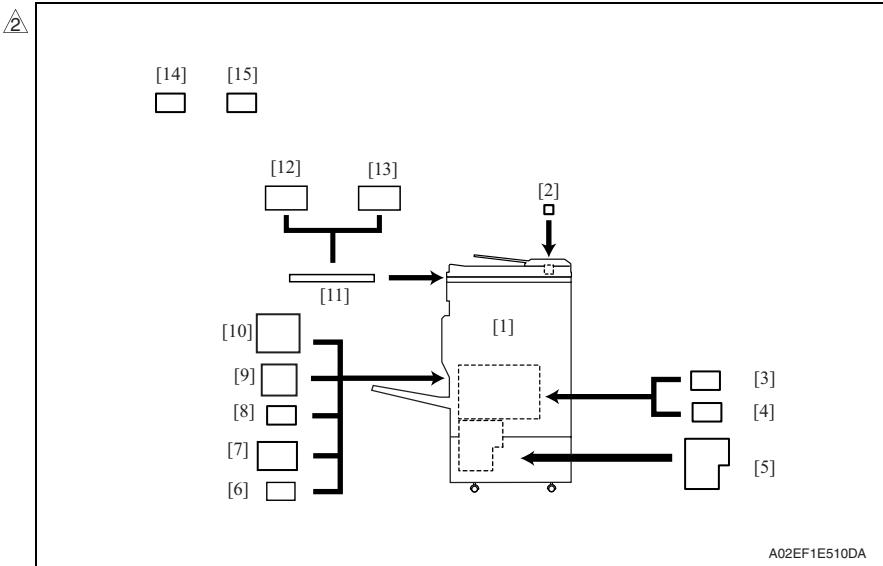

A02EF1E510DA

- |                            |             |   |
|----------------------------|-------------|---|
| [1] Main body              | [9] Fax kit | FK-502                                    |
| [2] Stamp unit             | SP-501      | [10] Mount kit                            |
|                            |             | MK-711                                    |
| [3] Security kit           | SC-503      | [11] Working table                        |
| [4] Video interface kit *1 | VI-504      | WT-502                                    |
| [5] Image controller *1    | IC-409      | [12] Authentication unit (biometric type) |
|                            |             | AU-101                                    |
|                            |             | [13] Authentication unit (IC card type)   |
|                            |             | AU-201                                    |
| [6] Scan accelerator kit   | SA-501      | [14] i-Option                             |
| [7] Fax multi line         | ML-501      | LK-101/102/103                            |
| [8] Local interface kit    | EK-603      | [15] Upgrade kit                          |
|                            |             | UK-201                                    |

\*1: Only for bizhub C353/C253, VI-504 and IC-409 are available with upgraded firmware that includes function enhancement.

## 2. Product specifications

### A. Type

Type	Desktop/console *1 scanner/printer
Printing process	Laser electrostatic printing system
PC drum type	OPC drum: KM-12 (OPC with high mold releasability)
Scanning density	600 dpi
Exposure lamp	White rare-gas fluorescent lamp 30 W
Platen	Stationary (mirror scan)
Original scanning	Mirror scanning CCD optical system * Sheet through system when DF-611 is used
Registration	Rear left edge
Paper feeding separation system	Manual bypass: Small roller separation system with torque limiter Tray 1 : Roller separation system with pick-up mechanism Tray 2 : Roller separation system with pick-up mechanism Tray 3 : Roller separation system with pick-up mechanism Tray 4 : Roller separation system with pick-up mechanism
Exposure system	<ul style="list-style-type: none"> <li>• Four-multi array PH unit system</li> <li>• Polygon mirror scan system</li> </ul>
Exposure density	Equivalent to 1800 dpi in main scanning direction × 600 dpi in sub scanning direction
Developing system	Dry 2 components developing method, HMT developing system
Charging system	DC comb electrode scorotron system with electrode cleaning function (manual)
Neutralizing system	Red LED system
Image transfer system	Belt image transfer system (1st)/roller image transfer system (2nd)
Paper separating system	Combination of curvature, separating claws, and bias system
Fusing system	Belt fusing
Heating system	Halogen lamp

\*1: Only when the optional paper feed cabinet/desk is installed.



**B. Functions**

Types of original		Sheets, books, and three-dimensional objects	
Max. original size		A3 or 11 x 17	
Max. original weight		Max. 2 kg	
Multiple copies		1 to 999	
Warm-up time (at ambient temperature of 23° C/73.4° F and rated source voltage)	When the sub power switch is turned ON at any timing while the main power switch remains ON for a predetermined period of time or more.		
	C353	30 sec. or less (Monochrome print) 41 sec. or less (Color print)	
	C253, C203	27 sec. or less (Monochrome print) 37 sec. or less (Color print)	
	When the sub power switch is turned ON immediately after the main power switch is turned ON.		
	C353	75 sec. or less (Monochrome print, Color print)	
	C253, C203	80 sec. or less (Monochrome print, Color print)	
⚠ Image loss	Copy	Leading edge: 4.2 mm (3/16 inch), Trailing edge: 3 mm (1/8 inch), Rear edge: 3 mm (1/8 inch), Front edge: 3 mm (1/8 inch)	
	PC print	Leading edge: 4.2 mm (3/16 inch), Trailing edge: 4.2 mm (3/16 inch), Rear edge: 4.2 mm (3/16 inch), Front edge: 4.2 mm (3/16 inch)	
First copy time	(Tray1/2 A4 or 8 1/2 x 11, full size)		
	C353	5.9 sec. or less (Monochrome print) 8.5 sec. or less (Color print)	
	C253, C203	7.7 sec. or less (Monochrome print) 11.7 sec. or less (Color print)	
Processing speed	Plain paper (monochrome, full color), OHP film *2	C353: 166.6 mm/s C253, C203: 111.0 mm/s	
	Thick 1, Thick 2, Thick 3, Thick 4, Post card, Envelope, Label sheet	C353, C253, C203: 55.5 mm/s	
Copying speed for multi-copy cycle (A4 or 8 1/2 x 11, plain paper)	Monochrome, Full color	C353: 1-sided: 35 copies/min, 2-sided: 35 copies/min	
		C253: 1-sided: 25 copies/min, 2-sided: 25 copies/min	
		C203: 1-sided: 20 copies/min, 2-sided: 20 copies/min	
Fixed zoom ratios	Full size	x1.000	
	Reduction	Metric area	x0.500, x0.707, x0.816, x0.866
		Inch area	x0.500, x0.647, x0.733, x0.785
	Enlargement	Metric area	x1.154, x1.224, x1.414, x2.000
		Inch area	x1.214, x1.294, x1.545, x2.000
	Zoom ratios memory	3 memories	
Variable zoom ratios	×0.250 to ×4.000	in 0.001 increments	

Paper size	Tray 1	Metric area	A3 to B5/B5S, A5S, 16K, 8K
		Inch area	11 x 17 to 8 1/2 x 11, 8 1/2 x 11S, 5 1/2 x 8 1/2S, 8 x 13
	Tray 2	Metric area	A3 to B5/B5S, A3 wide, 16K, 8K
		Inch area	12 x 18 to 8 1/2 x 11, 8 1/2 x 11S, 5 1/2 x 8 1/2S, 8 x 13
	Manual bypass tray	Metric area	A3 to B6S, A6S, A3 wide, banner paper, 16K/16KS, 8K
		Inch area	12 x 18 to 5 1/2 x 8 1/2, 5 1/2 x 8 1/2S, 4 x 6S, 8 x 13
Copy exit tray capacity	Plain paper	250 sheets	
	Thick paper	10 sheets	
	OHP film	1 sheet	

**C. Paper**

Type		Paper source (maximum tray capacity)		
		Tray 1	Tray 2	Multiple bypass
Copy paper type	Plain paper (60 to 90 g/m <sup>2</sup> / 16 to 24 lb)	○ (500 sheets)	○ (500 sheets)	○ (150 sheets)
	Translucent paper	—	—	—
	OHP film (crosswise feeding only) *2	—	—	○ (20 sheets)
	Thick paper 1 (91 to 150 g/m <sup>2</sup> / 24.25 to 40 lb)	150 sheets	150 sheets	
	Thick paper 2 (151 to 209 g/m <sup>2</sup> / 40.25 to 55.5 lb)			
	Thick paper 3 (210 to 256 g/m <sup>2</sup> / 55.75 to 68 lb) *1			
	Thick paper 4 (256 to 271 g/m <sup>2</sup> / 68 lb to 72 lb) *1	—	—	
	Postcards	—	—	
	Envelopes	—	—	○ (10 sheets)
	Labels	—	—	○ (20 sheets)
Long size paper (127 to 210 g/m <sup>2</sup> / 33.75 to 55.75 lb)	—	—	○ (10 sheets)	
Copy paper dimensions	Width	139.7 to 297 mm 5 1/2 to 11 3/4 inch	139.7 to 311.1 mm 5 1/2 to 12 1/4 inch	90 to 311.1 mm 3 1/2 to 12 1/4 inch
	Length	182 to 431.8 mm 7 1/4 to 17 inch	182 to 457.2 mm 7 1/4 to 18 inch	139.7 to 457.2 mm 5 1/2 to 18 inch
	Long size paper (Width x Length)	—	—	210 to 297 mm x 457.3 to 1200 mm or less 8 1/4 to 11 3/4 inch x 18 to 47 1/4 inch or less

\*1: Image is not guaranteed when thick paper 3/4 is used.

\*2: Monochrome print only.

Automatic duplex unit : Only the plain paper weighing 64 to 90 g/m<sup>2</sup> (17 to 24 lb) or thick paper weighing 91 to 256 g/m<sup>2</sup> (24.25 to 68 lb) are reliably fed.

**D. Maintenance**

- bizhub C353

Machine durability		800,000 prints or 5 years, whichever is earlier
No. of pages printed per month (average)	Color print	1,800 prints
	Monochrome print	7,400 prints
Standard copy mode	Color print	4pages/job
	Monochrome print	4 pages/job
Standard original density	Color print	C, M, Y, K 5%
	Monochrome print	K 5%

- bizhub C253

Machine durability		600,000 prints or 5 years, whichever is earlier
No. of pages printed per month (average)	Color print	1,000 prints
	Monochrome print	4,100 prints
Standard copy mode	Color print	3 pages/job
	Monochrome print	3 pages/job
Standard original density	Color print	C, M, Y, K 5%
	Monochrome print	K 5%

- bizhub C203

Machine durability		400,000 prints or 5 years, whichever is earlier
No. of pages printed per month (average)	Color print	700 prints
	Monochrome print	2,600 prints
Standard copy mode	Color print	2 pages/job
	Monochrome print	2 pages/job
Standard original density	Color print	C, M, Y, K 5%
	Monochrome print	K 5%

**E. Machine specifications**

Power requirements	Voltage:	AC 100 V, 120 V, 127 V, 220-240 V	
	Current:	100 V	15 A
		110 V	15 A
		120 V	12 A
		127 V	12 A
		230 V	8 A
Frequency:	50/60 Hz ± 3 Hz		
Max power consumption	1,500 W or less		
Dimensions	643 *1 (W) x 852 (H) x 770 mm (H) *2 25.25 *1 (W) x 33.5 (D) x 30.25 inch (H)		
Space requirements	991 (W) x 852 mm (D) *2 39 (W) x 33.5 inch (D) *2  1,653 (W) x 1,168 mm (D) *3 65 (W) x 46 inch (D) *3		
Weight	Machine	Approx. 99 kg / 218.25 lb (without IU and TC)	
	IU and TC	Approx. 6.8 kg / 15 lb	

\*1: Width when the manual bypass tray is closed

\*2: Height up to the original glass

\*3: When the finisher is separated and the paper feed tray is slide out

**F. Operating environment**

Temperature	10 to 30° C / 50 to 86° F (with a fluctuation of 10° C / 18° F or less per hour)
Humidity	15 to 85% (Relative humidity with a fluctuation of 10%/h)
Levelness	Difference between front and back, right and left should be 1 degree or under.

**G. Print functions**

Type	Built-in type controller	
Print speed	C353	35 prints/min (color/monochrome, A4, 1-sided)
	C253	25 prints/min (color/monochrome, A4, 1-sided)
	C203	20 prints/min (color/monochrome, A4, 1-sided)
First print time	C353	5.9 sec. or less (monochrome, A4)
	C253	7.7 sec. or less (monochrome, A4)
	C203	7.7 sec. or less (monochrome, A4)
Resolution	Data processing	600 x 600 dpi (print function, FAX function) 400 x 400 dpi (FAX function) 200 x 200 dpi (FAX function)
	Printing	Equivalent to 1800 dpi in main scanning direction x 600 dpi in sub scanning direction
Printer language	PCL5e/c emulation PCL XL Ver. 2.1 emulation PostScript 3 emulation (3016) XPS Ver. 1.0	
RAM	1024 MB	
Hard Disk	60 GB	
Host interface	Ethernet (10Base-T or 100Base-TX) USB 2.0/1.1	
Network protocol	TCP/IP(IPv4/IPv6), BOOTP, ARP, ICMP, DHCP, AutoIP, SLP, SNMP, FTP, LPR/LPD, RAW Socket, SMB over TCP/IP, IPP, HTTP, POP, SMTP, LDAP, NTP, SSL, IPX/SPX, AppleTalk, Bonjour, NetBEUI, WebDAV, WSD, S/MIME, IPsec, DNS, DynamicDNS	
Network print service	Pserver (NDS) ... NetWare 4.x, 5.x, 6.x Pserver (Bindery) ... NetWare 4.x NDPS ... NetWare 5.x, 6.x SMB, RAW port printing IPP 1.1 LPD	
Driver	PCL6 printer driver	<ul style="list-style-type: none"> <li>• Windows NT4.0 (SP6a or later)</li> <li>• Windows 2000 Professional (SP4 or later)</li> <li>• Windows XP Home Edition/Professional (SP2 or later)</li> <li>• Windows XP Professional x64</li> <li>• Windows Vista Home Basic /Home Premium /Ultimate /Business /Enterprise, Windows Vista Home Basic/ Home Premium /Ultimate /Business /Enterprise x64 edition</li> <li>• Windows Server 2003, Windows Server 2003 x64</li> </ul>
	PS3 printer driver	<ul style="list-style-type: none"> <li>• Windows 2000 Professional (SP4 or later)</li> <li>• Windows XP Home Edition/Professional (SP2 or later)</li> <li>• Windows XP Professional x64,</li> <li>• Windows Vista Home Basic /Home Premium /Ultimate /Business /Enterprise, Windows Vista Home Basic/ Home Premium /Ultimate /Business /Enterprise x64 edition</li> <li>• Windows Server 2003, Windows Server 2003 x64</li> </ul>



⚠ Driver	PostScript PPD driver	<ul style="list-style-type: none"> <li>• Macintosh OS 9.2 or later</li> <li>• Macintosh OS X 10.2/10.3/10.4</li> </ul>
	Fax driver	<ul style="list-style-type: none"> <li>• Windows NT4.0 (SP6a or later)</li> <li>• Windows 2000 Professional (SP4 or later)</li> <li>• Windows XP Home Edition/Professional (SP2 or later)</li> <li>• Windows XP Professional x64</li> <li>• Windows Vista Home Basic /Home Premium /Ultimate /Business /Enterprise, Windows Vista Home Basic /Home Premium /Ultimate /Business /Enterprise x64 edition</li> <li>• Windows Server 2003, Windows Server 2003 x64</li> </ul>
	XPS driver	<ul style="list-style-type: none"> <li>• Windows Vista XPS mini driver</li> </ul>
Utility	PageScope Web Connection	
Compatible paper size	Max. standard paper size A3 Wide (Long size paper: Width 210 mm to 297 mm x Length 457.3 mm to 1200 mm)	
Power requirements	Shared with Main body	
Operating environmental requirements	10 to 30° C (50 to 86° F) 15 to 85 %	
Fonts	PCL	Latin 80 fonts
	PS	Latin 137 fonts

**H. Scan functions**

Driver	KONICA MINOLTA scanner driver	
Compatible operating systems	Windows / NT4.0 SP6 / 2000 / XP/Vista	
Scan speed (A4 or 8 1/2 x 11)	Monochrome, Full color	70 pages/min (Resolution 300 dpi)
Scannable range	Same as the copier (Max. A3)	
Functions	Scan to E-mail, Scan to FTP, Scan to SMB, Scan to BOX	
Resolution	200/300/400/600 dpi	

**NOTE**

- These specifications are subject to change without notice.

Blank Page

# Maintenance

## 3. Periodical check

### 3.1 Service schedule

#### 3.1.1 Main body

##### A. bizhub C353

Guarantee period: 5-year or 800,000 prints

Service item	x 10,000-print															No. of times				
	6	12	15	18	20	24	30	36	40	42	45	48	54	60	66		72	75	78	
Upon each call (60,000)	●	●		●			●	●	●		●		●	●	●	●	●		●	13
150,000			●				●				●			●			●			5
200,000					●				●					●						3
300,000							●							●						2
400,000									●											1

##### B. bizhub C253

Guarantee period: 5-year or 600,000 prints

Service item	x 10,000-print													No. of times	
	6	12	15	18	20	24	30	36	40	42	45	48	54		
Upon each call (60,000)	●	●		●			●	●	●		●		●	●	9
150,000			●				●				●				3
200,000					●				●						2
300,000							●								1
400,000									●						1

##### C. bizhub C203

Guarantee period: 5-year or 400,000 prints

Service item	x 10,000-print								No. of times
	6	12	15	18	20	24	30	36	
Upon each call (60,000)	●	●		●		●	●	●	6
150,000			●				●		2
200,000					●				1
300,000							●		1



**3.1.2 Options**

**A. DF-611**

Guarantee period: 5-year or 1,200,000 originals feed

Service item	x 10,000 originals feed															No. of times								
	5	10	15	20	25	30	35	40	45	50	55	60	65	70	75		80	85	90	95	100	105	110	115
50,000	●	●	●	●	●	●	●	●	●	●	●	●	●	●	●	●	●	●	●	●	●	●	●	23
200,000				●				●			●					●				●				5

**B. PC-104/204/405**

Guarantee period: conforms to the guarantee period of the main body

Service item	x 10,000-print															No. of times								
	6	12	15	18	20	24	30	36	40	42	45	48	54	60	66		72	75	78					
300,000							●							●										2

**C. FS-519**

Guarantee period: conforms to the guarantee period of the main body

Service item	x 10,000-print															No. of times								
	6	12	15	18	20	24	30	36	40	42	45	48	54	60	66		72	75	78					
300,000							●							●										2

**D. FS-609**

Guarantee period: conforms to the guarantee period of the main body

Service item	x 10,000-print															No. of times								
	6	12	15	18	20	24	30	36	40	42	45	48	54	60	66		72	75	78					
300,000							●							●										2

## 3.2 Maintenance items

### NOTE

- **Cleaning/replacement cycle for each maintenance item of main body/options can be evaluated with each life counter value of [Service mode] → [Counter] → [Life].**

### 3.2.1 Main body

#### A. Parts to be replaced by users (CRU)

No	Class	Parts to be replaced	Cycle	Clean	Replace	Descriptions
1	Processing sections	Imaging unit Y,M,C	C353:90,000 C253:75,000 C203:55,000		●	*1
2		Imaging unit K	C353:120,000 C253:100,000 C203:70,000		●	*1
3		Toner cartridge Y,M,C	C353:20,000 C253:19,000 C203:19,000		●	*1
4		Toner cartridge K	C353:26,000 C253:24,500 C203:24,500		●	*1
5		Electrostatic charger wire	When toner cartridge K is replaced		●	
6	Image transfer section	Waste toner box	(50,000)		●	*1,2

\*1: The parts can be replaced either by user or service engineer.

For details of setting, see [Unit Change] on "Adjustment/Setting."

See P.396

\*2: A waste toner full condition is detected with detecting the actual waste toner emissions.

#### B. Maintenance call (per 60,000-print)

No.	Class	Parts to be replaced	Qt.	Check	Clean	Replace	Lubri- cation	Descriptions
1	Overall	Paper feed and image conditions	—	●				
2		Appearance	—	●	●			
3	Conveyance section	Timing roller	—		●			
4	Image transfer section	Around waste toner port	—		●			
5	Duplex section	Duplex transport roller	—		●			

**C. Periodical parts replacement/cleaning 1 (per 150,000-print)**

No.	Class	Parts to be replaced	Qt.	Check	Clean	Replace	Lubri- cation	Descrip- tions
1	Overall	Paper feed and image conditions	—	●				
2		Appearance	—	●	●			
3	Image transfer section	Image transfer entrance guide	—		●			
4		IDC/registration sensor	—		●			
5		Transfer belt unit	1			●		
6		Transfer roller unit	1			●		
7	Processing sections	Ozone filter	1			●		



**D. Periodical parts replacement/cleaning 2 (per 200,000-print)**

No.	Class	Parts to be replaced	Qt.	Check	Clean	Replace	Lubri- cation	Descrip- tions
1	Overall	Paper feed and image conditions	—	●				
2		Appearance	—	●	●			
3	Manual bypass tray	Feed roller	1			●		*1
4		Separation roller assy	1			●		

\*1: Replace those parts at the same time.

**E. Periodical parts replacement/cleaning 3 (per 300,000-print)**

No.	Class	Parts to be replaced	Qt.	Check	Clean	Replace	Lubri- cation	Descrip- tions
1	Overall	Paper feed and image conditions	—	●				
2		Appearance	—	●	●			
3	Tray1, Tray 2	Pick-up roller	1			●		*1
4		Feed roller	1			●		
5		Separation roller assy	1			●		

\*1: Replace those parts at the same time.

**F. Periodical parts replacement/cleaning 3 (per 400,000-print)**

No.	Class	Parts to be replaced	Qt.	Check	Clean	Replace	Lubri- cation	Descrip- tions
1	Overall	Paper feed and image conditions	—	●				
2		Appearance	—	●	●			
3	Fusing section	Fusing unit	1			●		

**3.2.2 DF-611**

**A. Maintenance call (per 50,000-original feed)**

No.	Class	Parts to be replaced	Qt.	Check	Clean	Replace	Lubri- cation	Descrip- tions
1	Overall	Paper feed and image conditions	—	●				
2		Appearance	—	●	●			
3	Paper feed section	Pick-up roller	—		●			
4		Feed roller	—		●			
5		Separation roller	—		●			
6	Conveyance section	Roller and rolls	—		●			
7	Scanning section	Scanning guide	—		●			
8	Paper feed section	Reflective sensor section	—		●			

**B. Periodical parts replacement/cleaning 1 (per 200,000-original feed)**

No.	Class	Parts to be replaced	Qt.	Check	Clean	Replace	Lubri- cation	Descrip- tions
1	Overall	Paper feed and image conditions	—	●				
2		Appearance	—	●	●			
3	Paper feed section	Pick-up roller	2			●		*1
4		Feed roller	1			●		
5		Separation roller	1			●		

\*1: Replace those three parts at the same time.

**3.2.3 PC-104/204/405**

**A. Periodical parts replacement/cleaning 1 (per 300,000-print)**

No.	Class	Parts to be replaced	Qt.	Check	Clean	Replace	Lubri- cation	Descrip- tions
1	Overall	Paper feed and image conditions	—	●				
2		Appearance	—	●	●			
3	Paper feed section	Pick-up roller	1			●		*1
4		Feed roller	1			●		
5		Separation roller	1			●		

\*1: Replace those three parts at the same time.

**3.2.4 FS-519**

**A. Periodical parts replacement/cleaning 1 (per 300,000-print)**

No.	Class	Parts to be replaced	Qt.	Check	Clean	Replace	Lubri- cation	Descrip- tions
1	Overall	Paper feed and image conditions	—	●				
2		Appearance	—	●	●			
3	Conveyance section	Paper feed roller, roll	—		●			
4		Paddle	—		●			

**B. Periodical parts replacement/cleaning 2 (per 800,000-print)**

No.	Class	Parts to be replaced	Qt.	Check	Clean	Replace	Lubri- cation	Descrip- tions
1	Overall	Paper feed and image conditions	—	●				
2		Appearance	—	●	●			
3	Conveyance section	Paddle	1			●		
4		Cleaning pad	1			●		
5		Worm gear	—		●		●	
6		Cover film	1			●		

**3.2.5 FS-609**

**A. Periodical parts replacement/cleaning 1 (per 300,000-print)**

No.	Class	Parts to be replaced	Qt.	Check	Clean	Replace	Lubri- cation	Descrip- tions
1	Overall	Paper feed and image conditions	—	●				
2		Appearance	—	●	●			
3	Conveyance section	Paper transport roller, roll	—		●			

### 3.3 Maintenance parts

- To ensure that the machine produces good copies and to extend its service life, it is recommended that the maintenance jobs described in this schedule be carried out as instructed.
- Replace with reference to the numeric values displayed on the Life counter.
- Maintenance conditions are based on the case of A4 or 8 1/2 x 11, standard mode and low power mode OFF.

		Color	B/W
*Standard mode	bizhub C353	4 pages per job	4 pages per job
	bizhub C253	3 pages per job	3 pages per job
	bizhub C203	2 pages per job	2 pages per job

#### 3.3.1 Replacement parts

##### A. Main body

No.	Classification	Parts name	Qt.	Actual durable cycle *1	Parts No.	Descriptions	Ref. page
1	Tray 1	Feed roller	1	300,000	A00J 5636 ##	*2	<a href="#">P.24</a>
2		Separation roller assy	1	300,000	A02E F566 ##		<a href="#">P.27</a>
3		Pick-up roller	1	300,000	A00J 5636 ##		<a href="#">P.24</a>
4	Tray 2	Feed roller	1	300,000	A00J 5636 ##	*2	<a href="#">P.28</a>
5		Separation roller assy	1	300,000	A02E F566 ##		<a href="#">P.31</a>
6		Pick-up roller	1	300,000	A00J 5636 ##		<a href="#">P.28</a>
7	Manual bypass tray	Feed roller	1	200,000	A02E 5947 ##	*2	<a href="#">P.32</a>
8		Separation roller assy	1	200,000	4034 0151 ##		<a href="#">P.34</a>
9	Processing section	Imaging unit Y,M,C	1	C353:90,000 C253:75,000 C203:55,000	—		<a href="#">P.37</a>
10		Imaging unit K	1	C353:120,000 C253:100,000 C203:70,000	—		
11		Ozone filter	1	150,000	A02E R730 ##	*3	<a href="#">P.41</a>
12	Processing section	Toner cartridge Y,M,C	1	C353:20,000 C253:19,000 C203:19,000	—		<a href="#">P.41</a>
13		Toner cartridge K	1	C353:26,000 C253:24,500 C203:24,500	—		
14	Image transfer section	Transfer roller unit	1	150,000 *5	A02E R713 ##		<a href="#">P.36</a>
15		Transfer belt unit	1	150,000	A02E R730 ##	*3	<a href="#">P.43</a>
16		Waste toner box	1	(50,000)	A0DT WY0	*4	<a href="#">P.35</a>
17	Fusing section	Fusing unit	1	400,000	A02E R733 ##	*6	<a href="#">P.46</a>
					A02E R720 ##	*7	
					A02E R721 ##	*8	

\*1: Actual durable cycle is the life counter value.

\*2: Replace those parts at the same time.

\*3: The ozone filter is furnished with the transfer belt unit so that all of them are replaced at one time.

- \*4: A waste toner full condition is detected with detecting the actual waste toner emissions.
- \*5: Because there is no life-counter for the transfer roller unit, substitute it by the life-counter of the transfer belt unit.
- \*6: 110 V areas only.
- \*7: 120 V areas only.
- \*8: 220-240 V areas only.

**B. Option**

No.	Classification	Parts name	Qt.	Actual durable cycle *1	Parts No.	Descriptions	Ref. Page
1	DF-611	Pick-up roller	2	200,000	9J07 3301 ##	*2	*3
2		Feed roller	1	200,000	4030 3005 ##		
3		Separation roller	1	200,000	9J07 3409 ##		
4	PC-104	Pick-up roller	1	300,000	A00J 5636 ##	*2	
5	PC-204	Feed roller	1	300,000	A02E F566 ##		
6	PC-405	Separation roller	1	300,000	A00J 5636 ##		
7	FS-519	Paddle	1	800,000	9J08 1605 ##		
			1		A01G 7203 ##		
8		Cleaning pad	1	800,000	A01G 7205 ##		
9		Cover film	1	800,000	A01G 8947 ##		

\*1: Actual durable cycle is the life counter value.

\*2: Replace those parts at the same time.

\*3: See each option service manual.

bizhub C353/C253/C203

Maintenance

**3.3.2 Cleaning parts**

No.	Classification	Parts name	Actual cleaning cycle *1	Descriptions	Ref.Page
1	Processing section	Electrostatic charger wire	When toner cartridge C/M/Y is replaced		P.22
2	Conveyance section	Timing roller	Upon each call (60,000)		P.22
3	Image transfer section	Area around the waste toner collecting port	Upon each call (60,000)		P.23
4		Image transfer entrance guide	When transfer belt unit is replaced (150,000)		P.45
5		IDC/registration sensor			P.45
6	Duplex section	Duplex transport roller	Upon each call (60,000)		P.23
7	DF-611	Pick-up roller	50,000		*1
8		Feed roller	50,000		
9		Separation roller	50,000		
10		Rollers and rolls	50,000		
11		Scanning guide	50,000		
12		Reflective sensor section	50,000		
13	FS-519	Paper feed roller, roll	300,000		*2
14		Paddle	300,000		
15		Worm gear	800,000		
△ 16	FS-609	Paper transport roller, roll	300,000		—

\*1: See DF-611 service manual.

\*2: See FS-519/PK-515/OT-602 service manual.



### 3.4 Concept of parts life

#### 3.4.1 Life value of consumables and parts

- The life counter value of each materials and parts is available from [Service Mode] → [Counter] → [Life].
- Life specification value means an actual life terminated when prints are made under the conditions as defined in the next section, "Conditions for life specifications values." The actual life may vary greatly depending on how the machine has been used and other factors.

	Description	Life value (Specification value)	Max. life value
Waste toner box	The waste toner full sensor detects the amount of toner accumulated in the waste toner box and sends a signal that determines the end of the waste toner box life.	50,000 *1,2	–
Fusing unit	When the number of printed pages *6 reaches the set life value shown on the right, the end of unit life is detected.	400,000	470,000 *3
Transfer belt unit	Comparing the number of printed pages *6 with the number of printed pages calculated based on how long the transfer belt has run, the machine detects the end of unit life when either of them reaches the set value shown on the right. (However, to detect whether the unit reaches the max. life value, the machine uses only the number of printed pages calculated based on how long the transfer belt has run.)	150,000	180,000 *3
Imaging unit C,M,Y	Comparing the PC drum rotation time with the PC drum rotation time calculated based on the number of printed pages *6, the machine detects the end of unit life when either of them reaches the set value shown in the table below.	See the imaging unit life values in the table below.	
Imaging unit K	* The PC drum rotation is calculated based on the distance the PC drum has run.		

<Imaging unit life value \*4>

		Life value (Specification value)		Max. life value	
		Normal *5	Long (Suspend) *5	Normal *5	Long (Suspend) *5
bizhub C353	Y,M,C	5,005 M	7,508 M	5,116 M	7,674 M
	K	5,674 M	8,511 M	5,769 M	8,654 M
bizhub C253	Y,M,C	8,334 M	12,501 M	8,557 M	12,836 M
	K	8,201 M	12,302 M	8,365 M	12,548 M
bizhub C203	Y,M,C	8,570 M	12,855 M	8,882 M	13,323 M
	K	8,560 M	12,840 M	8,805 M	13,208 M

- \*1: A waste toner full condition is detected with detecting the actual waste toner emissions.
- \*2: Once the toner-full is detected, it has to be replaced with the new waste toner box in order to reset.
- \*3: The initiation of any new print cycle is inhibited when reaching the max. life value.
- \*4: The mark "M" is indicated the value of the number of distance through which the PC drum has run translated to a corresponding value of the number of hours and the value.

- \*5: “Normal” and “Long” are the settings provided in [Service Mode] → [System 1] → [IU Life Setting]. (The options available on the display are [Normal] / [Suspend], if the firmware of function enhanced version 1 or later is installed.)
- \*6: The count condition is different according to the paper length of the sub scanning direction.

Paper length of sub scanning direction	Count value
Less than 216 mm	1 count
216 mm to 432 mm	2 counts
432 mm to 648 mm	3 counts
648 mm to 864 mm	4 counts
over 864 mm	5 counts

### 3.4.2 Conditions for life specifications values

Item		Description
Job type	bizhub C353	Monochrome : Making 4 copies per job Color : Making 4 copies per job
	bizhub C253	Monochrome : Making 3 copies per job Color : Making 3 copies per job
	bizhub C203	Monochrome : Making 2 copies per job Color : Making 2 copies per job
Paper size		A4 or 8 1/2 x 11
CV/M	bizhub C353	Black: 7,400 / Color: 1,800
	bizhub C253	Black: 4,100 / Color: 1,000
	bizhub C203	Black: 2,600 / Color: 700
Original density (Coverage)	Color	5 % for each color
	Monochrome	K 5 %
Low power mode		OFF
No. of operating days per month		20 days (main power switch turned ON and OFF 20 times per month)

### 3.4.3 Control causing inhibited printing for one part when an inhibited-printing event occurs in another part

- In order to reduce the maintenance call times: when printing prohibiting is reached for any of the following parts, make printing prohibited also for other parts whose life value is reached, and replace those parts at the same time.

Target parts: Fusing unit, image transfer belt unit, imaging unit /C, imaging unit /M, imaging unit /Y, imaging unit /K

### 3.5 Maintenance procedure (periodical check parts)

#### NOTE

- The alcohol described in the cleaning procedure of maintenance represents the isopropyl alcohol.

#### 3.5.1 Cleaning of the electrostatic charger wire

##### A. Periodically cleaning parts/cycle

- Electrostatic charger wire: when toner cartridge K is replaced

##### B. Procedure

1. Open the front door.

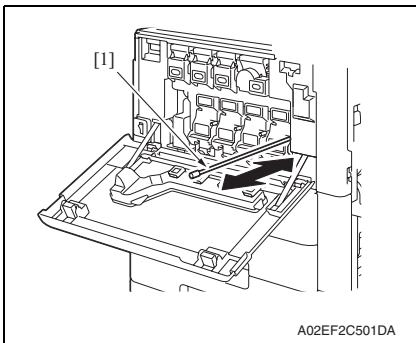

2. Slowly pull out the charger-cleaning tool [1] as far as possible. Next, slowly push in the charger cleaning tool as far as possible. Repeat the above operations three times.

#### NOTE

- Move the charger-cleaning tool slowly all the way to the end of either way.

#### 3.5.2 Cleaning of the timing roller

##### A. Periodically cleaning parts/cycle

- Timing roller: Every 60,000 prints (upon each call)

##### B. Procedure

1. Open the right door.

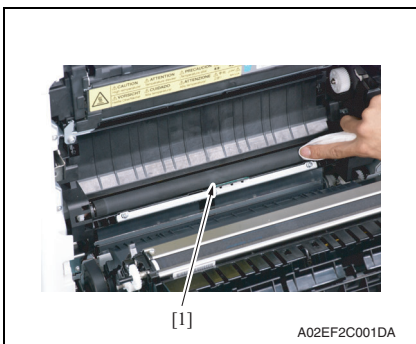

2. Using a cleaning pad with alcohol, wipe the timing roller [1] clean of dirt.

### 3.5.3 Cleaning of the area around the waste toner collecting port

#### A. Periodically cleaning parts/cycle

- Area around the waste toner collecting port: Every 60,000 prints (upon each call)

#### B. Procedure

1. Remove the waste toner box.

See P.35



2. Wipe the areas around the waste toner collecting port clean of spilled toner and dirt using a cleaning pad with water or alcohol.

### 3.5.4 Cleaning of the duplex transport rollers

#### A. Periodically cleaning parts/cycle

- Duplex transport rollers: Every 60,000 prints (upon each call)

#### B. Procedure

1. Open the duplex door.

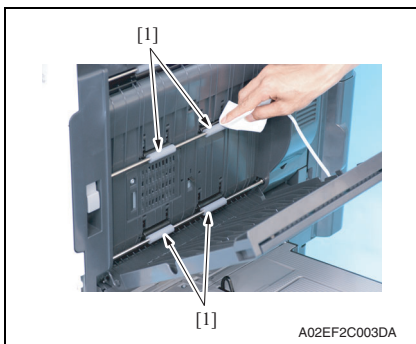

2. Using a cleaning pad with alcohol, wipe the transport rollers [1] clean of dirt.

### 3.5.5 Replacing the tray 1 feed roller/tray 1 pick-up roller

#### A. Periodically replacing parts/cycle

- Tray 1 feed roller: Every 300,000 prints
- Tray 1 pick-up roller: Every 300,000 prints

#### B. Procedure

1. Slide out the tray 1.
2. Remove the manual bypass tray unit.  
[See P.103](#)

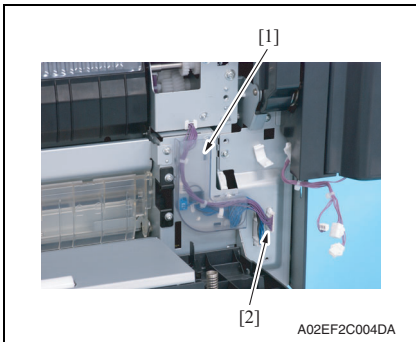

3. Remove the harness cover [1], and disconnect the connector [2].

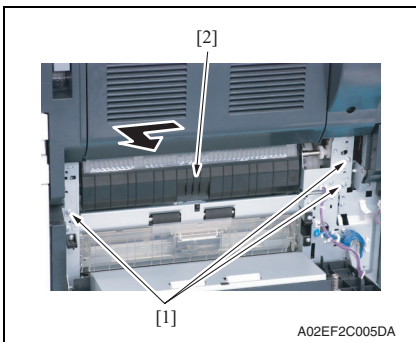

4. Remove three screws [1], and remove the tray 1 paper feed assy [2].

#### NOTE

- The tray 1 paper feed assy is positioned by the shaft that passes through the back frame of the assy. When removing the tray 1 paper feed assy, slide it in the direction of the arrow.

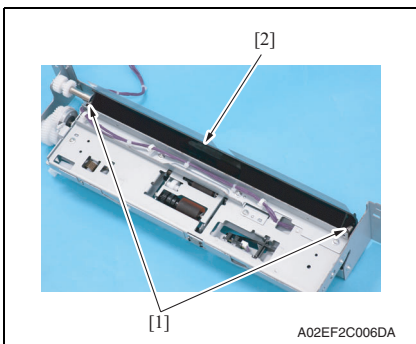

5. Remove two springs [1], and remove the cover [2].

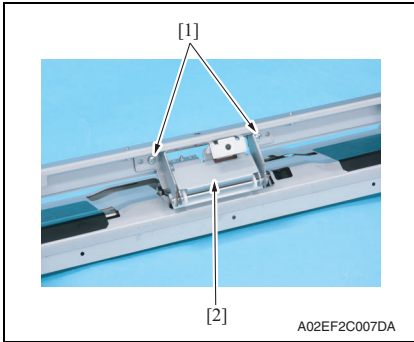

6. Remove two screws [1], and remove the tray 1 separation roller assy [2].

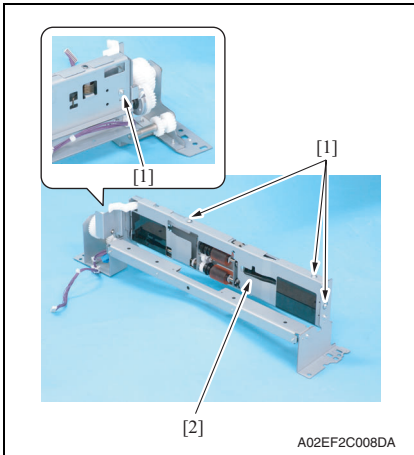

7. Remove four screws [1], and remove the tray 1 feed roller cover [2].

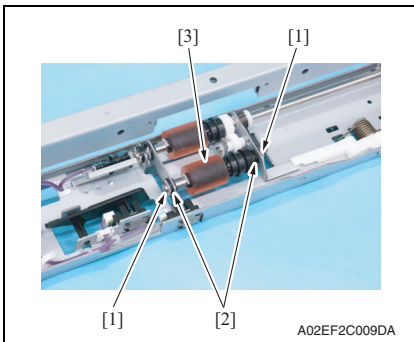

8. Remove two C-clips [1] and two bearings [2], and remove the tray 1 pick-up roller assy [3].

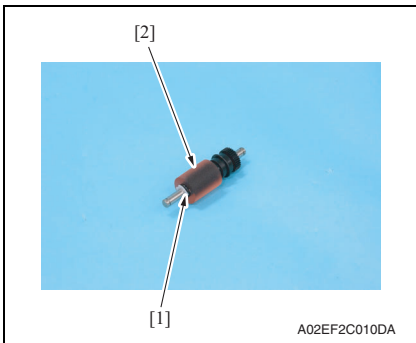

9. Remove the C-clip [1], and remove the tray 1 pick-up roller [2].

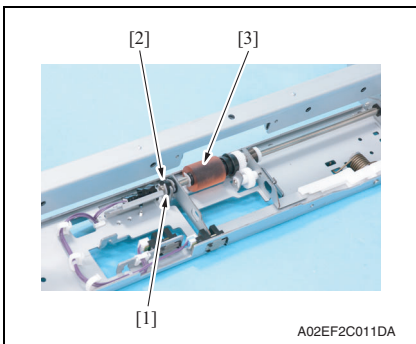

10. Remove the C-clip [1] and the bearing [2].  
Slide the tray 1 feed roller assy [3].

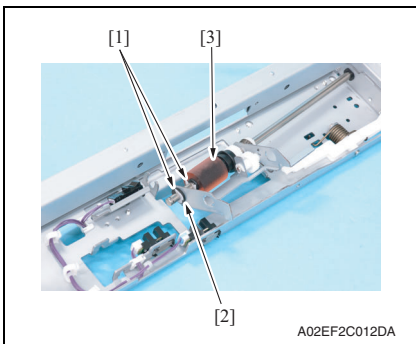

11. Remove two C-clips [1] and the bearing [2], and remove the tray 1 feed roller [3].

12. To reinstall, reverse the order of removal.

13. Replace the tray 1 separation roller assy.

[See P.27](#)

14. Select [Service Mode] → [Counter] → [Life] and clear the count of [1st.].

[See P.404](#)

### 3.5.6 Replacing the tray 1 separation roller assy

#### A. Periodically replacing parts/cycle

- Tray 1 separation roller assy: Every 300,000 prints

#### B. Procedure

1. Slide out the tray 1.
2. Remove the manual bypass tray unit.  
[See P.103](#)
3. Remove the tray 1 separation roller assy.

[See the replacement procedures 1 to 6 in "Tray 1 feed roller/tray 1 pick-up roller."](#)  
[See P.24](#)

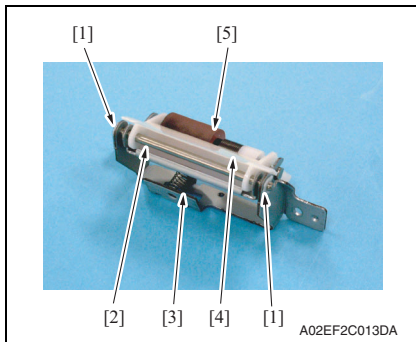

4. Remove two C-clips [1], the shaft [2], spring [3], and guide [4].  
Remove the separation roller fixing plate assy [5].

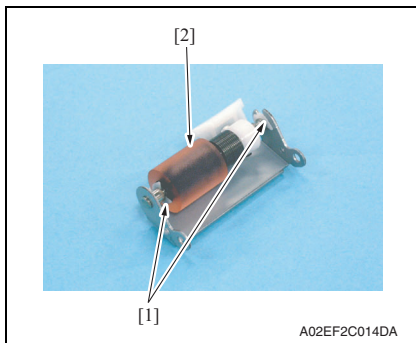

5. Remove two C-clips [1], and remove the tray 1 separation roller assy [2].

6. To reinstall, reverse the order of removal.



### 3.5.7 Replacing the tray 2 feed roller/tray 2 pick-up roller

#### A. Periodically replacing parts/cycle

- Tray 2 feed roller: Every 300,000 prints
- Tray 2 pick-up roller: Every 300,000 prints

#### B. Procedure

1. Slide out the tray 2.
2. Remove the vertical transport door.  
[See P.93](#)
3. Remove the rear right cover /3.  
[See P.91](#)

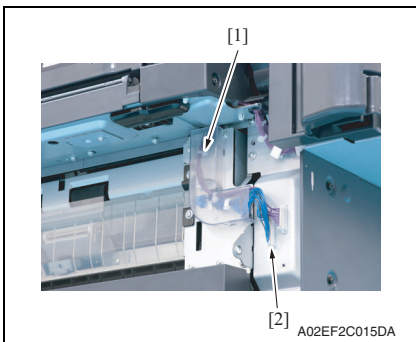

4. Remove the harness cover [1], and disconnect the connector [2].

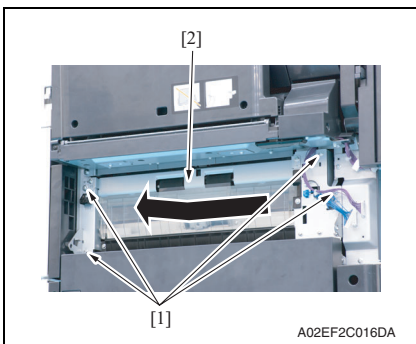

5. Remove four screws [1], and remove the tray 2 paper feed assy [2].

#### NOTE

- **The tray 2 paper feed assy is positioned by the shaft that passes through the back frame of the assy. When removing the tray 2 paper feed assy, slide it in the direction of the arrow.**

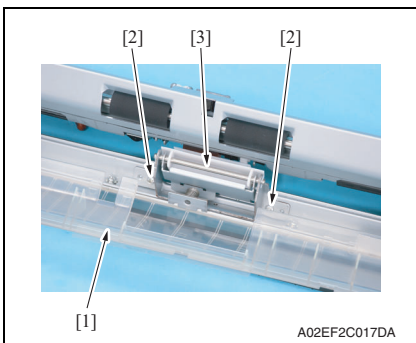

6. Lower the jam clearing cover [1], remove two screws [2], and remove the tray 2 separation roller assy [3].

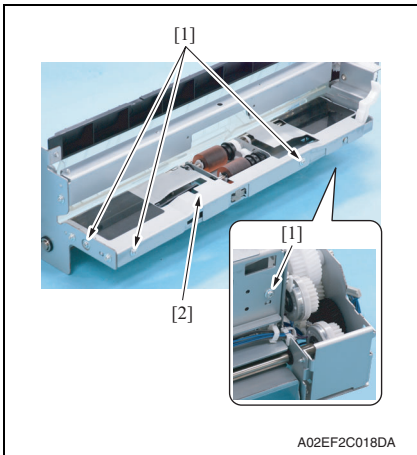

7. Remove four screws [1], and remove the tray 2 paper feed cover [2].

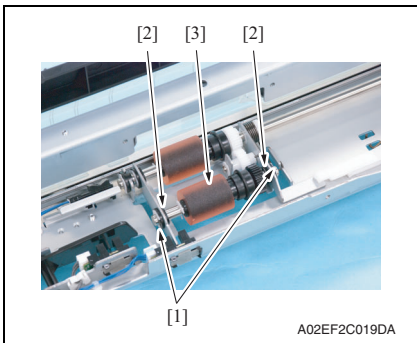

8. Remove two C-clips [1] and two bearings [2], and remove the tray 2 pick-up roller assy [3].

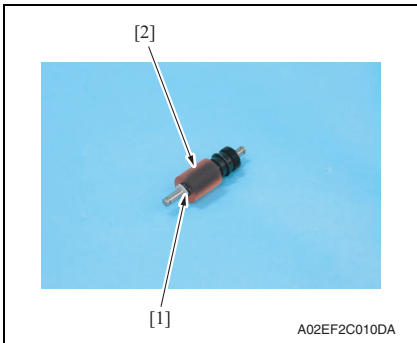

9. Remove the C-clip [1], and remove the tray 2 pick-up roller [2].

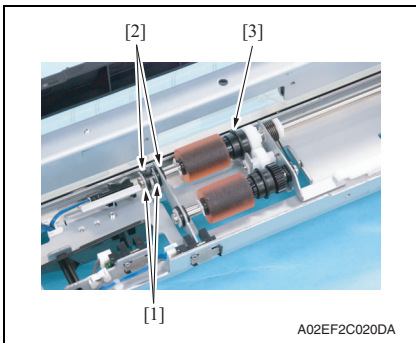

10. Remove two C-clips [1] and two bearings [2]. Slide the tray 2 feed roller [3] in the direction of the arrow.

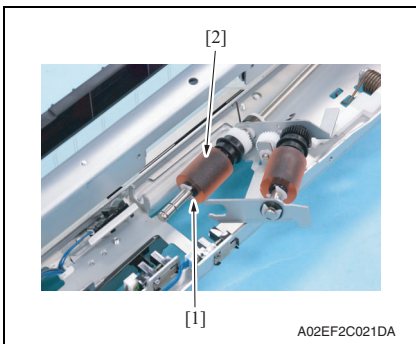

11. Remove the C-clip [1], and remove the tray 2 feed roller [2].

12. To reinstall, reverse the order of removal.

13. Replace the tray 2 separation roller assy.

[See P.31](#)

14. Select [Service Mode] → [Counter] → [Life] and clear the count of [2nd.].

[See P.404](#)

### 3.5.8 Replacing the tray 2 separation roller assy

#### A. Periodically replacing parts/cycle

- Tray 2 separation roller assy: Every 300,000 prints

#### B. Procedure

1. Slide out the tray 2.
2. Open the vertical transport door.

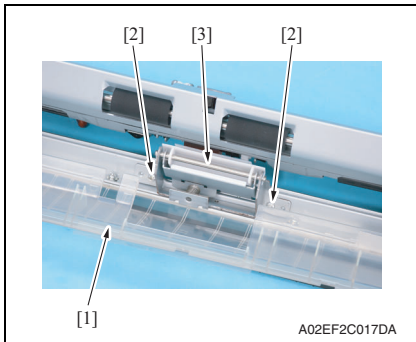

3. Opening the jam clearing cover [1], remove two screws [2], and remove the tray 2 separation roller assy [3].

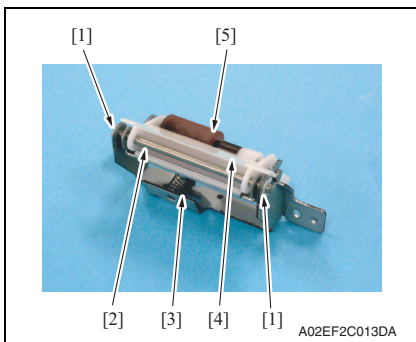

4. Remove two C-clips [1], the shaft [2], spring [3], and cover [4]. Remove the separation roller fixing plate assy [5].

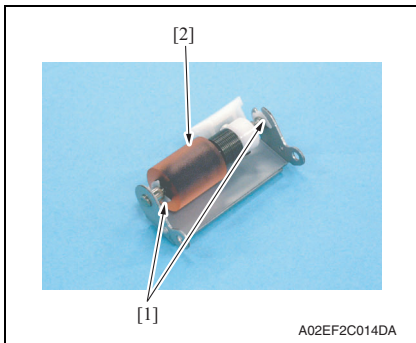

5. Remove two C-clips [1], and remove the tray 2 separation roller assy [2].

6. To reinstall, reverse the order of removal.

### 3.5.9 Replacing the manual bypass tray feed roller

#### A. Periodically replacing parts/cycle

- Manual bypass tray feed roller: Every 200,000 prints

#### B. Procedure

1. Remove the manual bypass tray unit.

See P.103

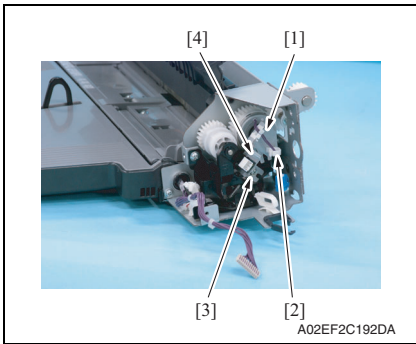

2. Remove the harness from the edge cover [1], and remove the wire saddle [2] and the screw [3].
3. Remove the metal plate [4].

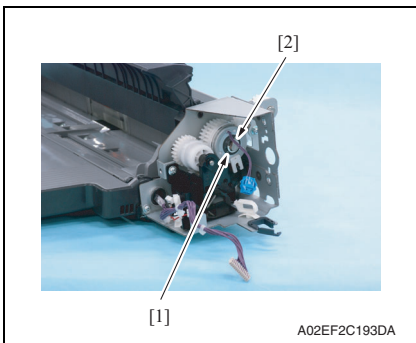

4. Remove the E-ring [1], and remove the manual paper feed clutch [2].

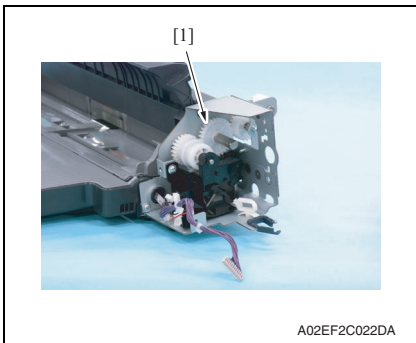

5. Remove the gear [1].

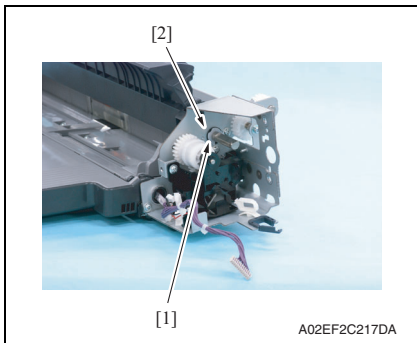

6. Remove the C-clip [1] and the bearing [2].

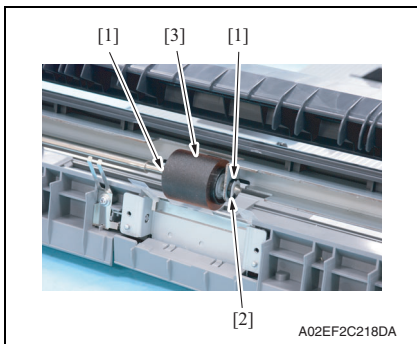

7. Remove two C-clips [1] and the bearing [2], and remove the manual bypass tray feed roller [3].

- 8. To reinstall, reverse the order of removal.
- 9. Replace the manual bypass tray separation roller assy.  
[See P.34](#)
- 10. Select [Service Mode] → [Counter] → [Life] and clear the count of [Manual Tray].  
[See P.404](#)

### 3.5.10 Replacing the manual bypass tray separation roller Assy

#### A. Periodically replacing parts/cycle

- Manual bypass tray separation roller Assy: Every 200,000 prints

#### B. Procedure

1. Remove the manual bypass tray unit.

See P.103

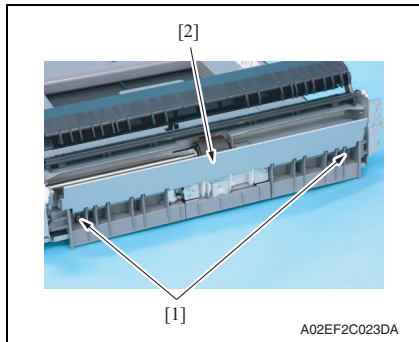

2. Remove two springs [1] and the guide plate [2].

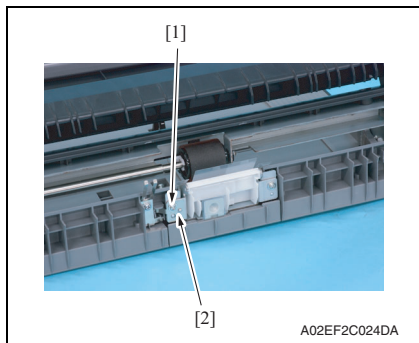

3. Remove the screw [1], and remove the ground terminal [2].

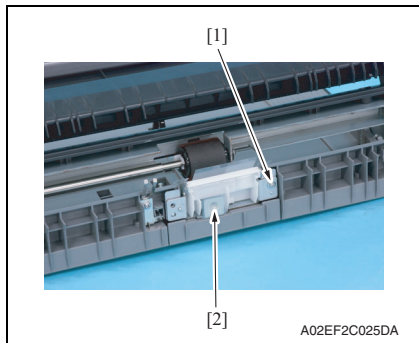

4. Remove the screw [1], and remove the manual bypass tray separation roller Assy [2].

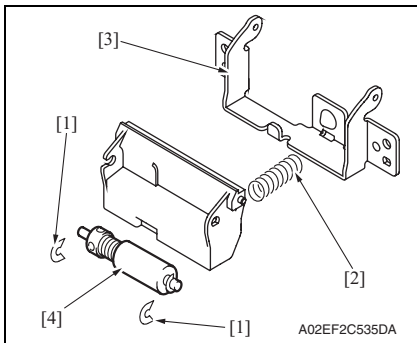

5. Snap off two C-clips [1], and remove the spring [2] and the guide plate [3]. Remove the manual bypass tray separation roller assy [4].

6. To reinstall, reverse the order of removal.

### 3.5.11 Replacing the waste toner box

#### A. Periodically replacing parts/cycle

- Waste toner box: Every 50,000 prints

#### B. Removal procedure

1. Open the front door.

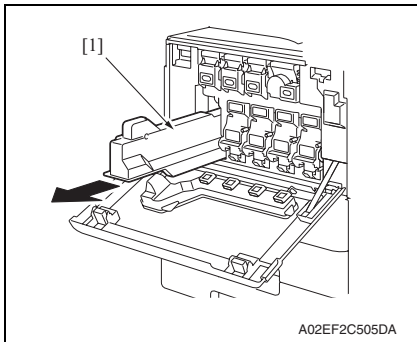

2. Raise the waste toner box [1] and remove it.

3. Clean the surface around the waste toner collecting port.  
[See P.23](#)



**C. Reinstall procedure**

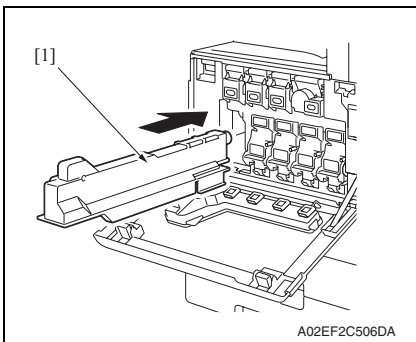

1. Remove a new waste toner box from its packaging and remove the packing material.
2. Place the waste toner box [1] in position.

3. Close the front door.

**3.5.12 Replacing the transfer roller unit**

**A. Periodically replacing parts/cycle**

- Transfer roller unit: Every 150,000 prints

**B. Removal procedure**

1. Open the right door.

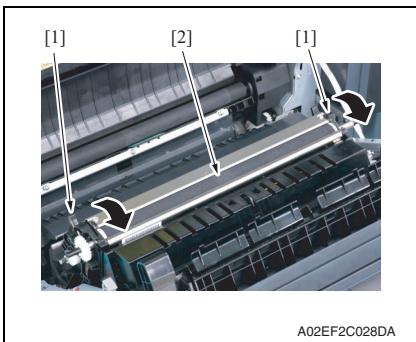

2. Unlock the lock levers [1] of the transfer roller unit (at two places).
3. Holding onto the lock levers [1] (at two places), remove the transfer roller unit [2].

**C. Reinstall procedure**

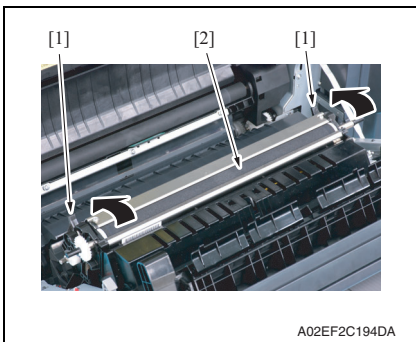

1. Holding onto the lock levers [1] (at two places), mount the new transfer roller unit [2].
2. Lock the lock levers [1] (at two places).

**NOTE**

- **Make sure that the levers are locked in position both at front and rear.**

3. Close the right door.

### 3.5.13 Replacing the imaging unit

#### A. Periodically replacing parts/cycle

- Imaging unit Y,M,C : Every 90,000 prints (bizhub C353)  
: Every 75,000 prints (bizhub C253)  
: Every 55,000 prints (bizhub C203)
- Imaging unit K : Every 120,000 prints (bizhub C353)  
: Every 100,000 prints (bizhub C253)  
: Every 70,000 prints (bizhub C203)

#### NOTE

- Although the procedure shown below is for the replacement of the imaging unit K, use the same procedure to replace other imaging units Y,M,C.

#### B. Removal procedure

1. Open the front door.

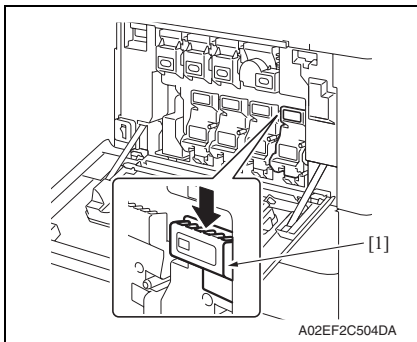

2. Press down to release the unlock lever [1] of the imaging unit to be replaced.

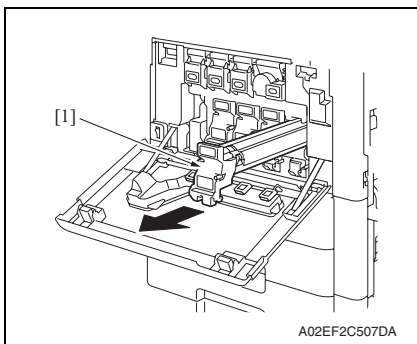

3. Remove the imaging unit [1].

### C. Reinstall procedure

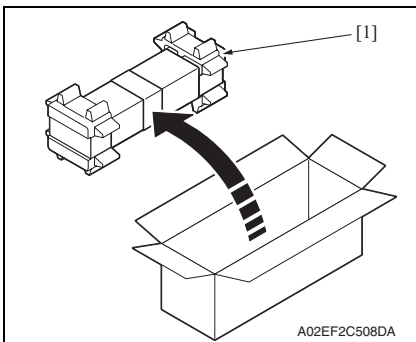

1. Remove the imaging unit [1] from its packaging.

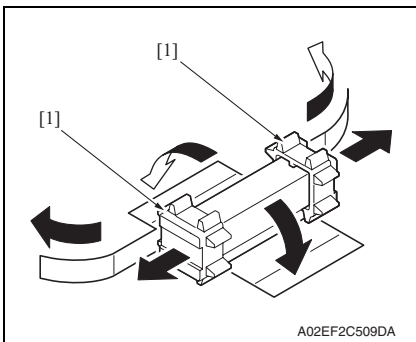

2. Peel off the tapes, and then remove the packing materials [1].

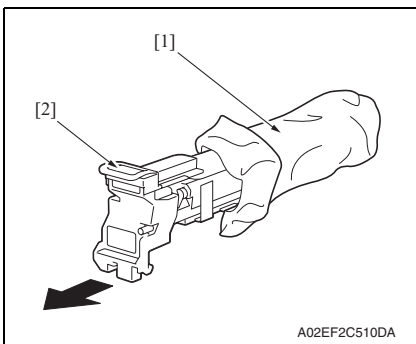

3. Remove the imaging unit [2] from the black protective bag [1].

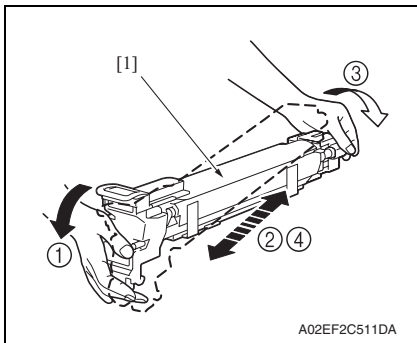

- 4. Tilt the imaging unit [1] to the left and shake it a little left to right twice. Then, tilt the imaging unit to the right and shake it a little right to left twice.

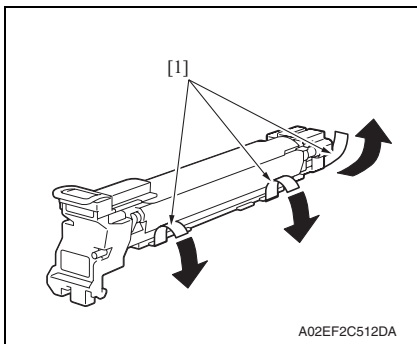

- 5. Peel off the tapes [1].

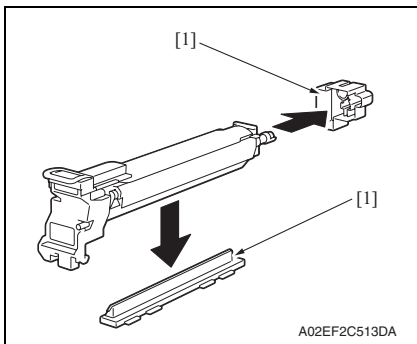

- 6. Remove the packing material and securing material [1].

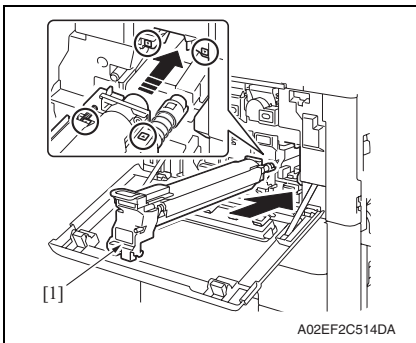

- 7. Align the ▲ mark on the imaging unit with the ▼ mark on the main body. Install the imaging unit [1] into the main body.

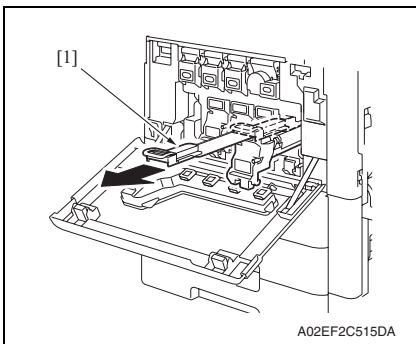

- 8. To remove the protective sheet [1] which guards against PC drum damage, slowly pull its tab.

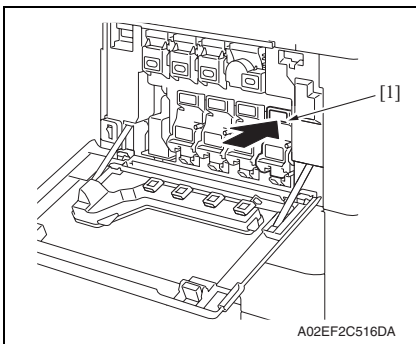

- 9. Insert the imaging unit [1] completely and close the front door.

### 3.5.14 Replacing the ozone filter

#### A. Periodically replacing parts/cycle

- Ozone filter: Every 150,000 prints

#### B. Procedure

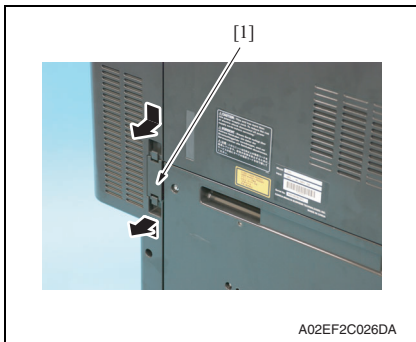

1. Grip the handle on the ozone filter [1] and slide it out of the main body.

### 3.5.15 Replacing the toner cartridge

#### A. Periodically replacing parts/cycle

- Toner cartridge Y,M,C : Every 20,000 prints (bizhub C353)  
: Every 19,000 prints (bizhub C253/C203)
- Toner cartridge K : Every 26,000 prints (bizhub C353)  
: Every 24,500 prints (bizhub C253/C203)

#### B. Removal procedure

1. Open the front door.

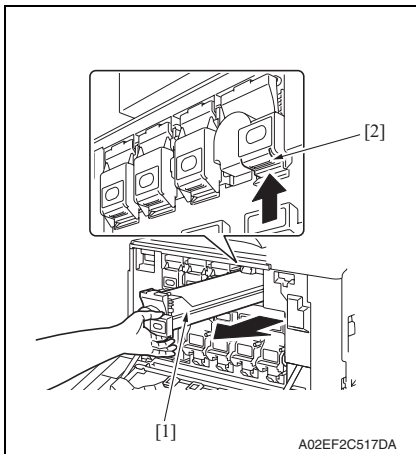

2. Pull up the locking tab [2] of the empty toner cartridge [1] to unlock it.
3. Pull out the toner cartridge [1] as far as possible, and then pull it up to remove it.

### C. Reinstall procedure

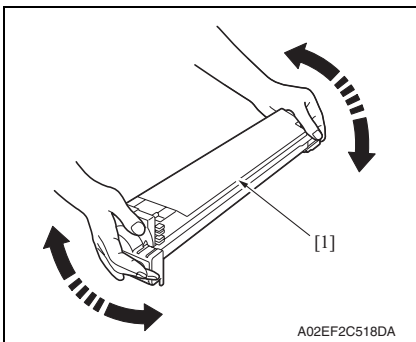

1. Remove the new toner cartridge [1] from its packaging, and then shake the cartridge up and down 5 to 10 times.

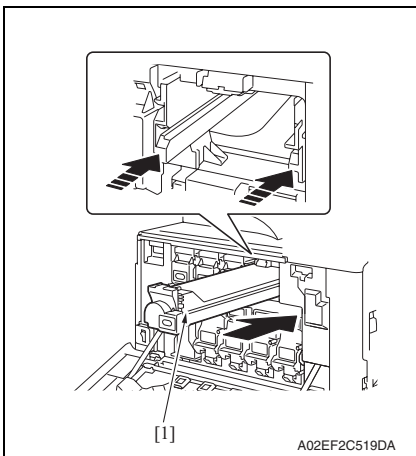

2. Align the toner cartridge [1] with the slots in the machine, and then insert the cartridge until the locking tab locks into place.

3. Clean the electrostatic charger wire.  
[See P.22](#)

### 3.5.16 Replacing the transfer belt unit

#### A. Periodically replacing parts/cycle

- Transfer belt unit: Every 150,000 prints

#### B. Removal procedure

1. Open the right door.

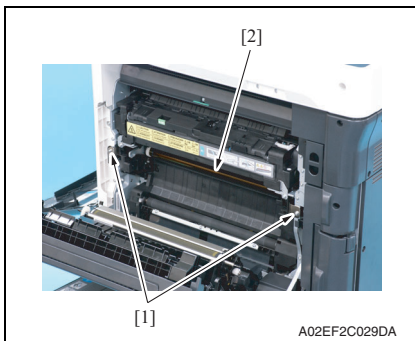

2. Remove two screws [1] and release the lock of the transfer belt unit [2].

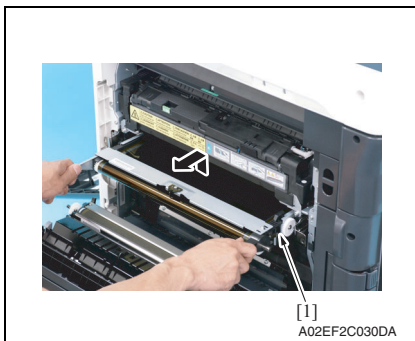

3. Hold the both sides and lift it to take out the transfer belt unit [1] a little.

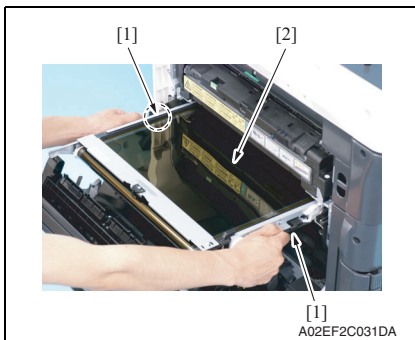

4. Hold the position [1] as shown in the left and remove the transfer belt unit [2].

#### NOTE

- Do not touch the surface of the Image transfer belt unit.
- Cover the image transfer belt unit with something such shade cloth to protect its surface from dust or foreign matter.



### C. Reinstall procedure

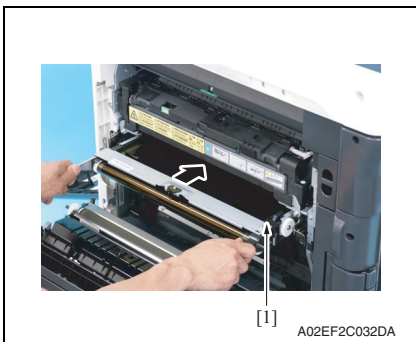

1. Insert the transfer belt unit [1].

**NOTE**

- Insert the transfer belt unit with care not to allow its docking gear to be damaged by hitting it against the rail or associated part.
- Do not touch the surface of the image transfer belt unit.
- Cover the image transfer belt unit with something such shade cloth to protect its surface from dust or foreign matter.

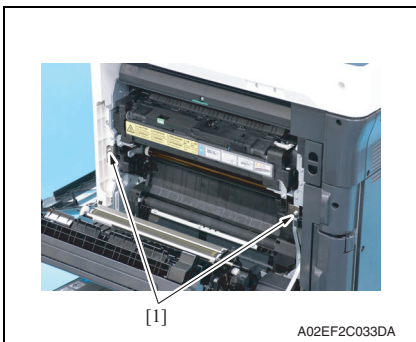

2. Install the transfer belt unit with two screws [1].

**NOTE**

- Replace the ozone filter, which is supplied with the transfer belt unit, at the same time.

3. Close the right door.
4. Turn ON the main power switch.
5. Select [Service Mode] → [Imaging Process Adjustment] → [Gradation Adjust] and carry out gradation adjust.

[See P.361](#)

### 3.5.17 Cleaning of the image transfer entrance guide

#### A. Periodically cleaning parts/cycle

- Image transfer entrance guide: When the transfer belt unit is replaced (every 150,000 print)

#### B. Procedure

1. Remove the transfer belt unit.

See P.43

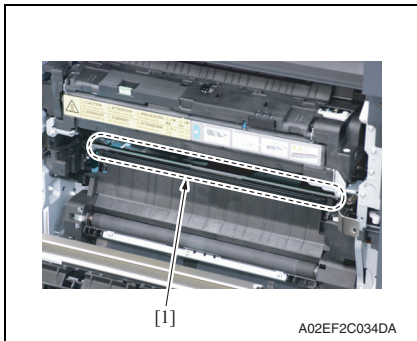

2. Wipe the image transfer entrance guide [1] clean of spilled toner and dirt using a cleaning pad with water or alcohol.

### 3.5.18 Cleaning of the IDC/registration sensor/MK,YC

#### A. Periodically cleaning parts/cycle

- IDC/registration sensor/MK,YC: When the transfer belt unit is replaced (every 150,000 print)

#### B. Procedure

1. Remove the transfer belt unit.

See P.43

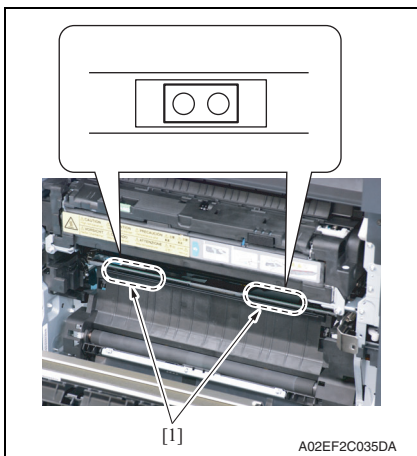

2. Wipe the surface of the IDC/registration sensor/MK,YC [1] clean of spilled toner and dirt using a cotton bud.

### 3.5.19 Replacing the fusing unit

#### CAUTION



- The temperature gets high in the vicinity of the fusing unit. You may get burned when you come into contact with the area. Before replacement operations, make sure that more than 20 minutes have elapsed since the main and sub power switches were turned off.

#### A. Periodically replacing parts/cycle

- Fusing unit: Every 400,000 prints

#### B. Procedure

1. Open the front door.
2. Open the right door.

3. Remove the screw [1], and remove the connector protective cover [2].

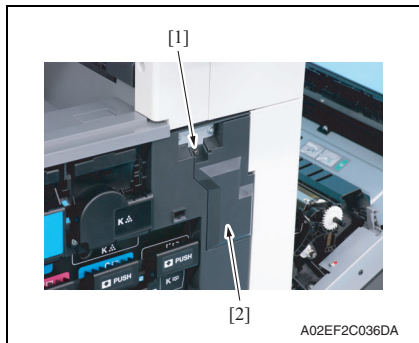

4. Disconnect three connectors [1].
5. Remove the harness from the wire saddle [2].

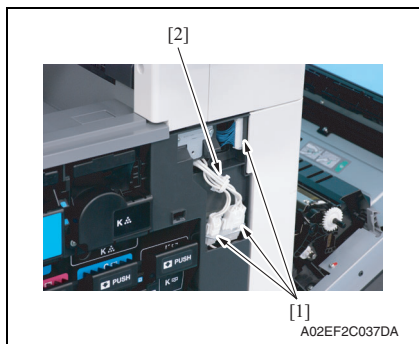

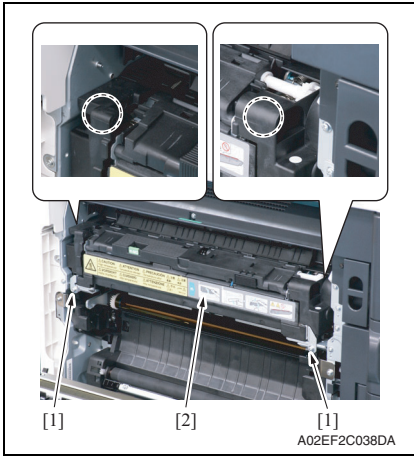



6. Remove two screws [1], and remove the fusing unit [2].

**NOTE**

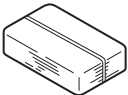

- **When removing the fusing unit, hold the parts shown on the picture on the left so that it would not fall.**

## 4. Service tool

### 4.1 Service material list

Name	Shape	Material No.	Remarks
Cleaning pad	 A02EF2C526DA	000V-18-1	10pcs/1pack
Isopropyl alcohol	 A00KF2C506DA	—	
Molykote EM-50L grease	 A00KF2C507DA	4478 7801 ##	Used with FS-519

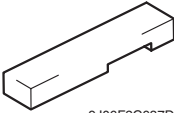
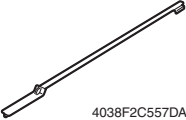
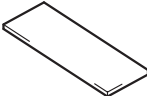
### 4.2 CE tool list

Tool name	Shape	Quantity	Parts No.	Remarks
Original glass moving unit height adjustment jig	 9J06F2C637DA	1	9J06 PJG0 ##	
PH window cleaning jig	 4038F2C557DA	1	4038 2083 ##	
PH window cleaning jig pad	 4038F2C558DA	1	4038 2084 ##	
Slit glass cleaning jig	 A00JF2C527DA	1	A01H 1005 ##	

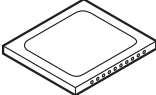
Tool name	Shape	Quantity	Parts No.	Remarks
Color chart	 A02EF2C520DA	1	9J06 PJP1 ##	A3
			9J06 PJP2 ##	11 x 17
Compact flash	 4037F2C601DA	1	V865400001 (blank)	*1

\*1: Inquire of KMBT about the part number of compact flash in which the firmware data is written.

### 4.3 Copy materials

#### 4.3.1 Imaging unit single parts (IU)

Parts name	Replacing period		
	bizhub C353	bizhub C253	bizhub C203
Imaging unit K	120,000 prints	100,000 prints	70,000 prints
Imaging unit Y	90,000 prints	75,000 prints	55,000 prints
Imaging unit M	90,000 prints	75,000 prints	55,000 prints
Imaging unit C	90,000 prints	75,000 prints	55,000 prints

[See P.20](#)

#### 4.3.2 Toner cartridge single parts (T/C)

Parts name	Replacing period		
	bizhub C353	bizhub C253	bizhub C203
Toner cartridge K	26,000 prints	24,500 prints	24,500 prints
Toner cartridge Y	20,000 prints	19,000 prints	19,000 prints
Toner cartridge M	20,000 prints	19,000 prints	19,000 prints
Toner cartridge C	20,000 prints	19,000 prints	19,000 prints

\*1: Life value that can be achieved with a probability of 90% even with product-to-product variations and fluctuating operating environmental conditions taken into consideration, when the T/C is used under the conditions of B/W ratio 5% for each color

#### 4.3.3 Waste toner box

Parts name	Replacing period *1
Waste toner box	50,000 prints *1

\*1: A waste toner full condition is detected with detecting the actual waste toner emissions.  
[See P.20](#)

#### 4.3.4 Maintenance kit

There is no setting for the maintenance kit.

## 5. Firmware upgrade

### 5.1 Outline

- There are two ways to update the firmware: One is by directly connecting with the main body using the compact flash, and the other is by downloading over a network using the Internet ISW.

### 5.2 Notes about firmware rewrite

#### 5.2.1 Types of firmware

- Two types of firmware are released for bizhub C353/C253/C203. They are a maintenance release version and an enhanced version.  
 Maintenance release version : Addresses remaining problems  
 Function enhanced version : Adds new features and includes the contents of the maintenance release version available at the same time
- The function enhanced version firmware is available in two types:  
 “Function Enhancement 1” and “Function Enhancement 2”
- Before rewriting a firmware, check the current firmware version of the machine and confirm the type of the current firmware using CSES.  
 Select an appropriate firmware and rewrite the current firmware.

#### 5.2.2 Rewrite to/from a function enhanced version of firmware

- The processing that ensures compatibility is required when upgrading the firmware to the function enhanced version.  
 HDD Version Up (LK) : To maintain the compatibility of management information data and documents stored in HDD after the firmware upgrade. (only for Function Enhancement 2).

#### NOTE

- **Firmware can be rewritten only through the menu operation on the control panel and cannot be rewritten with the CS Remote Care system.**
- Take the following steps to perform processing that ensures compatibility.

#### **A. Upgrade to the function enhancement 2 from the early mass-production firmware/function enhancement 1**

1. After rewriting the firmware, turn OFF and ON the main power switch and sub power switch.
2. Trouble code C-E002 is displayed.
3. Call the Service Mode to the screen.
4. Touch [State Confirmation] → [Memory/HDD Adj.] → [HDD Version Up (LK)].
5. Check to see that the Start key is lit in blue. Touch the Start key to initiate version up.
6. When version up is completed, the result is displayed on the screen.
7. Turn OFF and ON the main power switch and sub power switch.

### 5.3 Preparations for firmware rewriting by Windows Command Prompt

#### 5.3.1 Service environment

- OS: Windows 2000/XP
- Drive which enables writing/reading of compact flash
- Compact flash (service tool)

#### 5.3.2 Writing into the compact flash

1. Put the data of firmware in the optional directory. (C:\bizhub in the below figure)

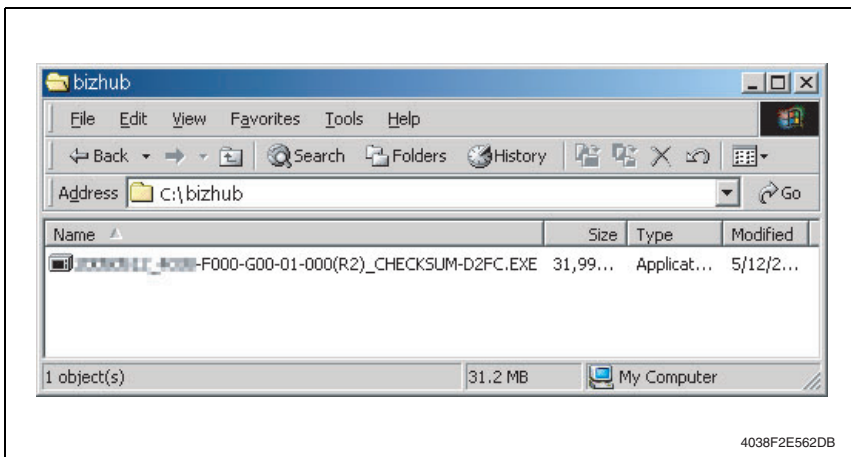

4038F2E562DB

#### NOTE

- The file name of firmware data consists of the “Release Date\_Version\_CHECKSUM-\*\*\*\*.exe.”
2. Double-click the firmware data, and specify the directory to be uncompressed, and then uncompress it.

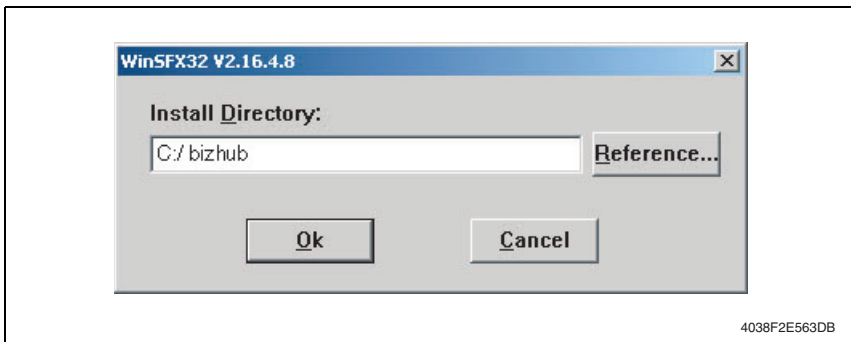

4038F2E563DB

#### NOTE

- When old firmware is still left in the specified directory to be uncompressed, delete it before uncompressing.
- When the firmware data is decompressed, “card\_work” folder is created in the selected directory and the data is decompressed in this folder.



- Mount the compact flash on the PC, and check the drive name, which was recognized in the Windows. (F-drive in the following figure)

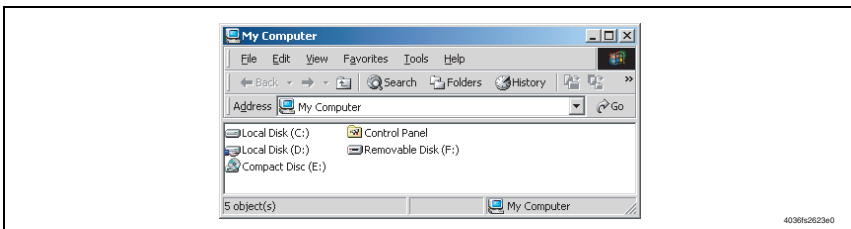

- Click [Start] → [Program] → [Accessories] → [Command Prompt] to open the command prompt.
- Use the command prompt to move into the uncompressed directory.
- Specify the drive of compact flash, which was recognized through the procedure 3, and execute the “mkcf.bat.” (Input the C:\bizhub\card\_work>mkcf ## f (drive number): in the below figure, and push the “Enter”).

**NOTE**

- For ## within the above mkcf command, type two characters that correspond to the machine model on which firmware upgrading is made. Take a look at the following list to find right characters for a correct command.

Model and command list	
bizhub C353	t1
bizhub C253	t2
bizhub C203	t25

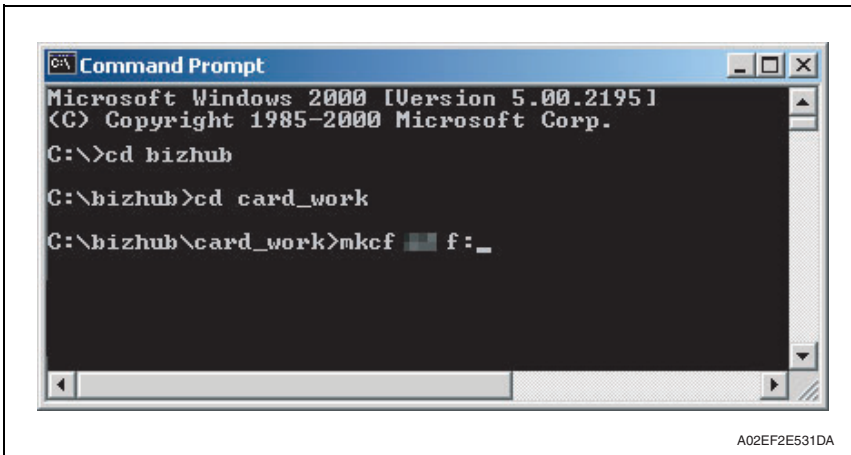

- Once the “mkcf.bat” is executed, data writing into the compact flash is started.

- 8. Upon completion of writing, CHECKSUM is executed. If CHECKSUM value is precisely matched, "VERIFY OK" appears.

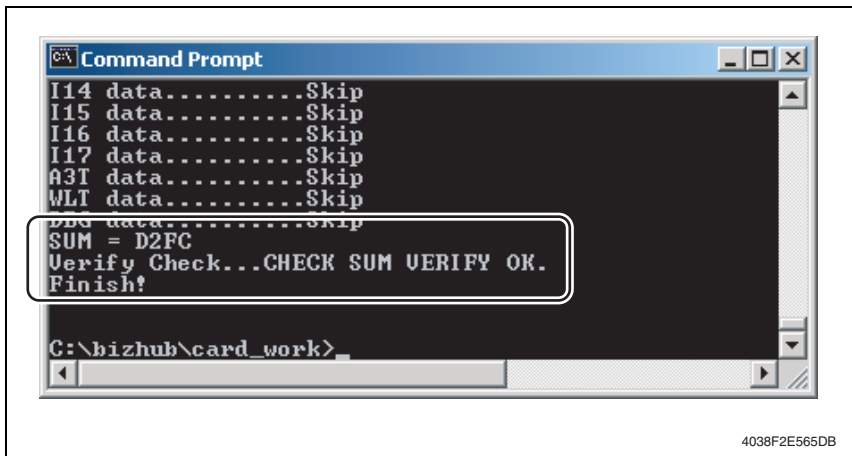

- 9. Remove the compact flash from PC.

**NOTE**

- When removing the compact flash, be sure to check if data is written as normal and then remove it according to the precise removing method.

## 5.4 Preparations for firmware rewriting by Firmware Imaging Toolkit 2006

- This software is designed as the tool to write firmware data of MFP/printer released by KMBT into the compact flash card.

### 5.4.1 Correspond model

- Correspond models of the software is as follows.

Color machine	<ul style="list-style-type: none"> <li>• bizhub C650/C550/C451/C450/C353/C352/C351/C350/C300/C253/C250/C203</li> <li>• bizhub C450P/C353P/C352P/C250P</li> </ul>
B/W machine	<ul style="list-style-type: none"> <li>• bizhub 350/250/200</li> <li>• Di3510/3510f/3010/3010f/2510/2510f</li> </ul>



### 5.4.2 Function outline

- The following functions are available with this software.

Function type	Function name	Description
Basic functions	Write Firmware to a card	<ul style="list-style-type: none"> <li>• Write firmware data into the compact flash card.</li> </ul> <a href="#">See P.60</a>
	Compare Firmware with a card	<ul style="list-style-type: none"> <li>• Compare the firmware data written into the compact flash card with the one saved in PC.</li> </ul> <a href="#">See P.60</a>
Advanced functions	Create a Firmware Image from a card	<ul style="list-style-type: none"> <li>• Create the firmware image form using the firmware data written into the compact flash card.</li> </ul> <a href="#">See P.61</a>
	Format a card	<ul style="list-style-type: none"> <li>• Format the compact flash card by the FAT or vxWorks form.</li> </ul> <p><b>NOTE</b></p> <ul style="list-style-type: none"> <li>• <b>vxWorks form is not applicable</b></li> </ul> <a href="#">See P.61</a>
	Display information about a card	<ul style="list-style-type: none"> <li>• Acquisition the information of firmware data written into the compact flash card.</li> </ul> <a href="#">See P.61</a>

### 5.4.3 System environment

- The following system environments are required or recommended to use the software.

Computer	<ul style="list-style-type: none"> <li>• IBM PC/AT compatible machine</li> </ul>
CPU	<ul style="list-style-type: none"> <li>• Pentium III / 500 MHz or higher is recommended.</li> </ul>
Correspond OS	<ul style="list-style-type: none"> <li>• Windows 2000, Windows XP or Windows Server 2003</li> </ul>
Required memory	<ul style="list-style-type: none"> <li>• More than 128 MB (Windows 2000), 256MB (Windows XP/2003) is recommended.</li> </ul>
Others	<ul style="list-style-type: none"> <li>• Drive that is able to Read/Write compact flash.</li> </ul>

### 5.4.4 Installation of software

- Follow the procedures shown below to install the software.

#### NOTE

- **Install the software to the PC with the administration authentication.**
- **When any anti-virus program is activated, quite the program before the installation.**

1. Double click [setup.exe] to start the installation of the software.



2. Click [Next >].

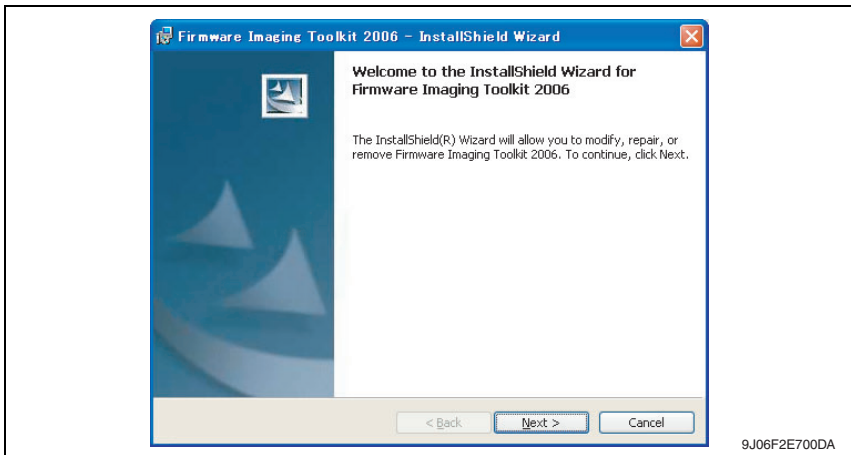

- 3. After checking the contents of license agreement, select [I accept the terms in the license agreement] and click [Next >].

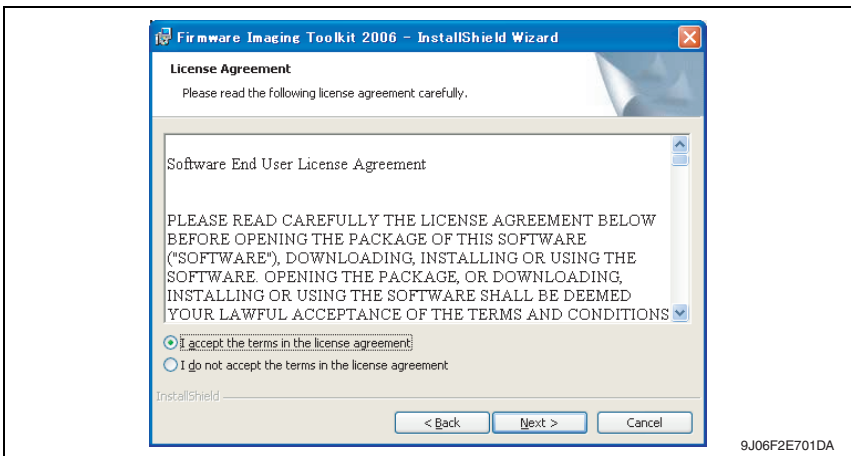

- 4. Select the installed destination folder of Firmware Imaging Toolkit 2006, and click [Next>].

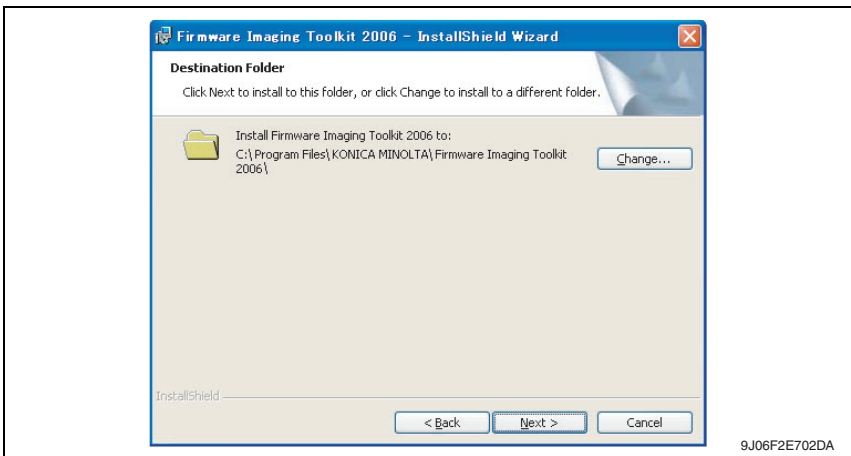

5. Click [Install] to start installation.
6. Click [Finish] to complete the installation.

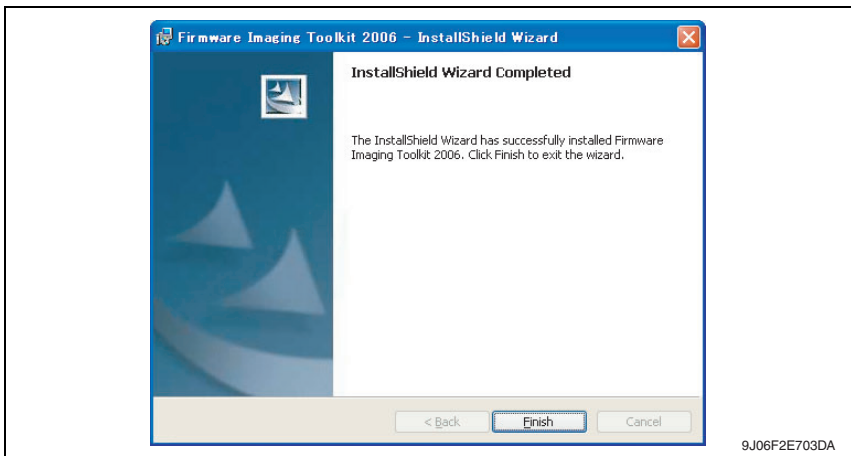

7. Shortcut file will be created inside Windows Start menu ([Program] → [KONICA MINOLTA] → [Firmware Imaging Toolkit 2006]).

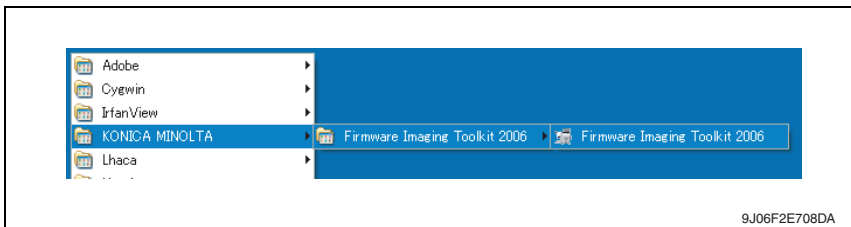

### 5.4.5 Update of software

- To update the software version, delete (uninstall) the currently installed program and install the new version.
  - Follow the procedures shown below to delete (uninstall) the program.
1. Quite the program if the software is activated.
  2. Select [Firmware Imaging Toolkit 2006] of [Add/Remove Programs] in Windows Control Panel menu to delete the program.

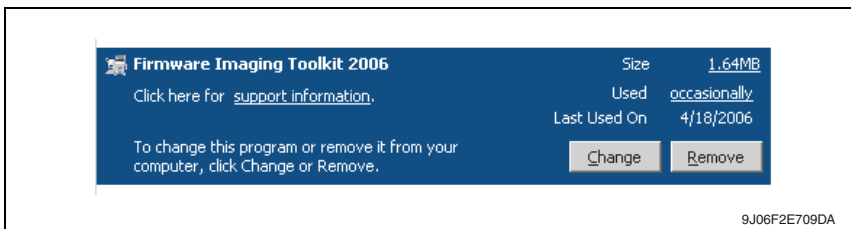

5.4.6 Screen

A. Main window

- The main window will be displayed after activating the software.
- Main window consists of 2 patterns: Basic mode, Advanced mode

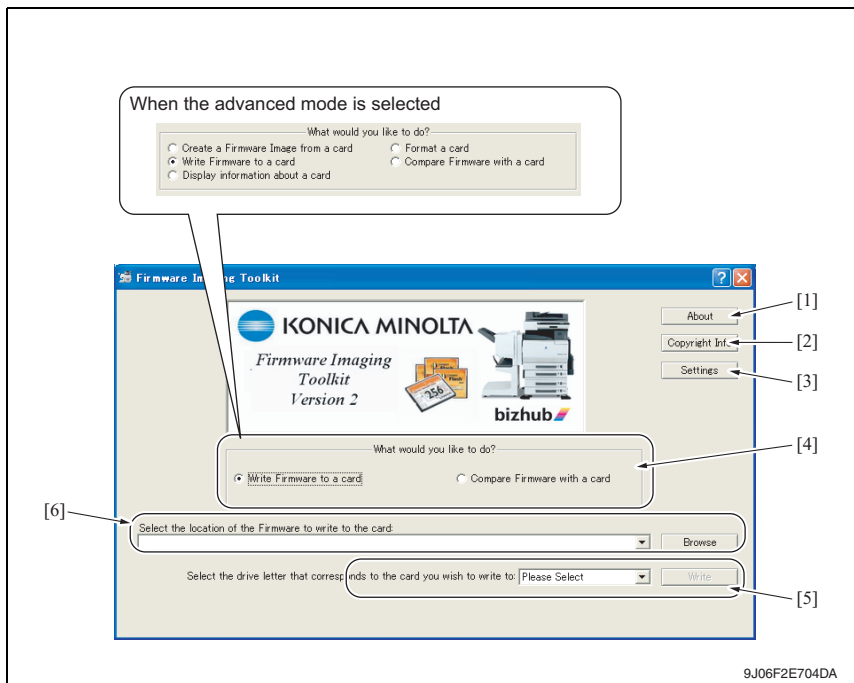

9J06F2E704DA

[1]	About	<ul style="list-style-type: none"> <li>• To display the outline of the tool.</li> </ul>
[2]	Copyright Info	<ul style="list-style-type: none"> <li>• To display the license agreement and version information of the tool.</li> </ul>
[3]	Settings	<ul style="list-style-type: none"> <li>• To display the dialog to enable the advanced functions.</li> <li>• Select the check box of [Enabled Advanced Features] to enable advanced functions at main window.</li> </ul> <p><a href="#">See P.59</a></p>
[4]	What would you like to do?	<ul style="list-style-type: none"> <li>• To select the function to be used.</li> <li>• Displayed screen is different between Basic mode and Advanced mode.</li> </ul> <p><a href="#">See P.60</a></p>
[5]	Select the location of the Firmware to write to the card:	<ul style="list-style-type: none"> <li>• To select the compact flash drive to which the data to write.</li> </ul>
[6]	Select the drive letter that corresponds to the card you wish to write to:	<ul style="list-style-type: none"> <li>• To select the location where the firmware is stored in PC.</li> </ul>

### B. Settings dialog

- It will be displayed by clicking [Settings] at main window.
- Other settings will be enabled by selecting the check box of [Enabled Advanced Features].

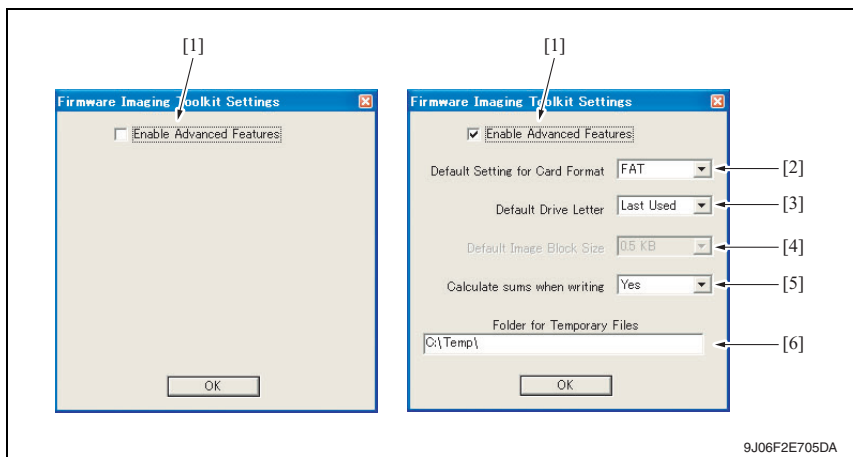

9J06F2E705DA

[1]	Enable Advanced Features	<ul style="list-style-type: none"> <li>• Enable the setting of advanced functions at the dialog by selecting the check box. Also advanced functions can be selected at the main window.</li> </ul>
[2]	Default Setting for Card Format	<ul style="list-style-type: none"> <li>• Select the default card format during software starting.                      FAT : The format to be used by all models that the software supports.                      vxWorks : Not available yet.</li> </ul>
[3]	Default Drive Letter	<ul style="list-style-type: none"> <li>• Select how to set default of compact flash drive during software starting.                      LastUsed : The drive used at previous time is selected.                      None : [Please Select] is displayed on the screen every starting and the drive should be selected every time.</li> </ul>
[4]	Default Image Block Size	<ul style="list-style-type: none"> <li>• Not available yet.</li> </ul>
[5]	Calculate sums when writing	<ul style="list-style-type: none"> <li>• Set whether to calculate check sums during data writing.</li> <li>• If [YES] is selected, data consistency can be ensured by data verification of check sums during data writing. However, it takes more time for data writing compared to the case without sums calculation. (Basically this mode shall be selected.)</li> <li>• If [No] is selected, check sums calculation is skipped during data writing. Although it take less time for data writing compared to the case with sums calculation, it fails to ensure the reliability of the written data.</li> </ul>
[6]	Folder for Temporary Files	<ul style="list-style-type: none"> <li>• Set the folder for saving temporary files during the tool is activating. The temporary file is automatically deleted after the operation completes normally.</li> </ul>



### 5.4.7 Details of each function

#### A. Basic functions

##### (1) Write Firmware to a card

- To write FW data into the compact flash. The FW data of the models shown below can be written.
- To write FW data into the compact flash. The FW data of the models shown below can be written.

<Corresponding models and firmware file type>

Models	File type	Indexed firmware type	Compressed firmware type	Uncompressed firmware type	Di3510/350/250/200 firmware type
C650		Mosel1_cf.tar.gz	*.img.gz	*.img	—
C550		Mosel2_cf.tar.gz			—
C451		Mosel3_cf.tar.gz			—
C353/C353P		thames1_cf.tar.gz			—
C253		thames2_cf.tar.gz			—
C203		thames25_cf.tar.gz			—
C450/C450P/C351		rhein1_cf.tar.gz			—
C352/C352P/C300		rhein2_cf.tar.gz			—
C350		tss2_cf.tar.gz			—
C250/C250P		rhein3_cf.tar.gz			—
Di3510/3510f/3010/ 3010f/2510/2510f		—	—	—	ma001
350/250/200		—	—	—	ma001a

#### NOTE

- The above-mentioned [Indexed firmware type] and [Di3510/350/250/200 firmware type] shall be comprised of multiple files and one of the files shall be named as above.
- [Compressed firmware type] means the compressed formed image file that is created using the tool's function of the [Create a Firmware Image from a card].
- [Uncompressed firmware type] means the image file that is uncompressed the compressed firmware file.
- To write the image file data (\*.img.gz or \*.img) into the compact flash, use the compact flash with the same capacity as the one used for the original image file. Although the compact flash with larger capacity than the original one can be used, it is not covered under warranty.
- C350 firmware requires the compact flash over 64 MB.
- Firmware of C650/C550/C451/C450/C450P/C353/C352/C352P/C351/C300/C253/C250/C250P/C203 requires the compact flash over 128 MB.

##### (2) Compare Firmware with a card

- Compare the firmware data written into the compact flash and the one (file) saved in PC.
- After the comparison, display the check sum information (comparison result dialog) of the firmware data of the compact flash and the file.
- The firmware data (file) format saved in PC shall consistent with the one written into the compact flash.

## B. Advanced functions

### (1) Create a Firmware Image from a card

- Create the image file from the firmware data written into the compact flash.  
Create the image file by dumping directly the data in the card. This function allows us to save the various type of firmware data in the compact flash as the image file and hold as copy data.
- The created FW image file is automatically compressed and created as the Compressed firmware file (\*.img.gz).

The image file is written into the compact flash in the uncompressed form, however, the uncompressed data would occupy too much capacity, which makes file control difficult. Therefore this tool doesn't create uncompressed firmware file (\*.img).

### (2) Format a card

- Make format of the compact flash in FAT or vxWork form.
- To write the firmware data into the compact flash, the card should be formatted in FAT form to clear (initialize) the description of the compact flash.

### NOTE

- **In current version, only FAT format is available but not vxWork format.**
- **After the firmware data is written into the compact flash, it becomes the own file style that is different from the FAT, and the compact flash that the firmware data is written cannot be browsed on the Windows OS.**

### (3) Display information about a card

- Display the information of the firmware data written into the compact flash.  
The information to be displayed is according to the type of written FW data.
- For the series of Di3510/200/250/350 series, MSC version is displayed.
- ⚠ For the series of C650/C550/C451/C450/C450P/C353/C353P/C352/C352P/C351/C350/C300/C253/C250/C250P/C203, check sums of each firmware data is displayed.

### 5.4.8 How to write firmware data

#### A. In the case of C650/C550/C451/C450P/C450P/C353/C353P/C352/C352P/C351/C350/C300/C253/C250/C250P/C203 series

1. Put the firmware data in the optional directory. (C:\bizhub in the below figure)

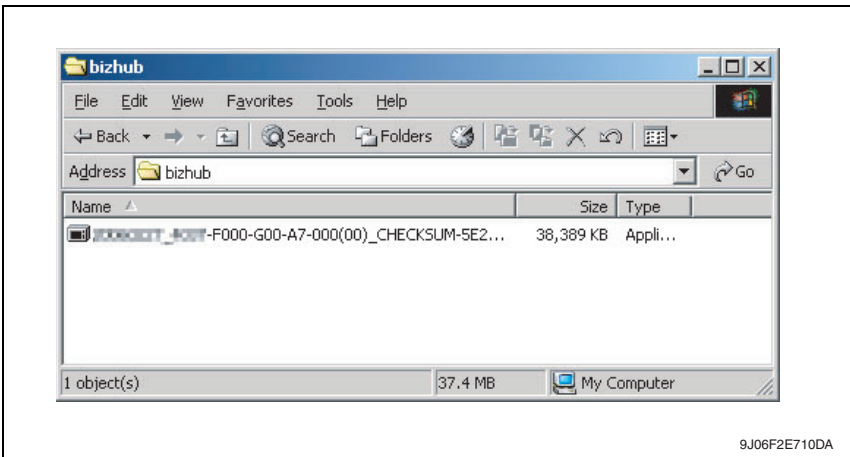

9J06F2E710DA

#### NOTE

- The file name of firmware data consists of the “Release Date\_Version\_CHECKSUM-\*\*\*\*.exe.”
2. Double-click the firmware data, and specify the directory to be uncompressed, and then uncompress it.

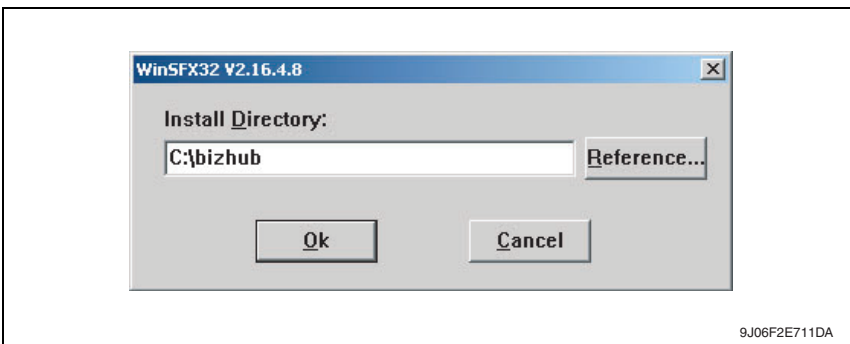

9J06F2E711DA

#### NOTE

- When old firmware is still left in the specified directory to be uncompressed, delete it before uncompressing.

3. Mount the compact flash on the PC, and check the drive name, which was recognized in the Windows. (F-drive in the following figure)

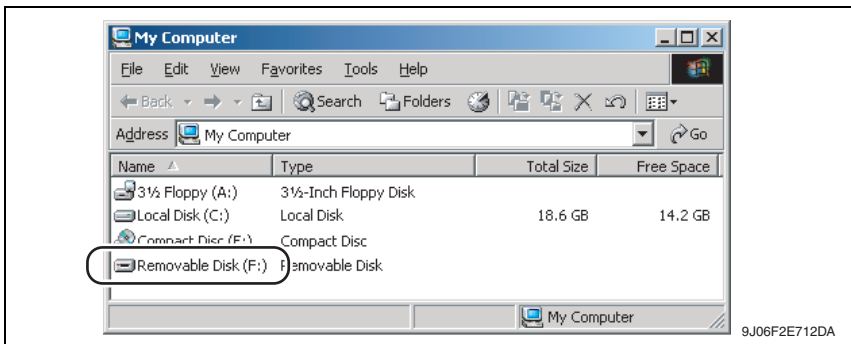

4. Start Firmware Imaging Toolkit 2006.

**NOTE**

- When using the external compact flash drive such as USB be sure to connect them before starting this tool.
5. Select the check box of [Write Firmware to a card].

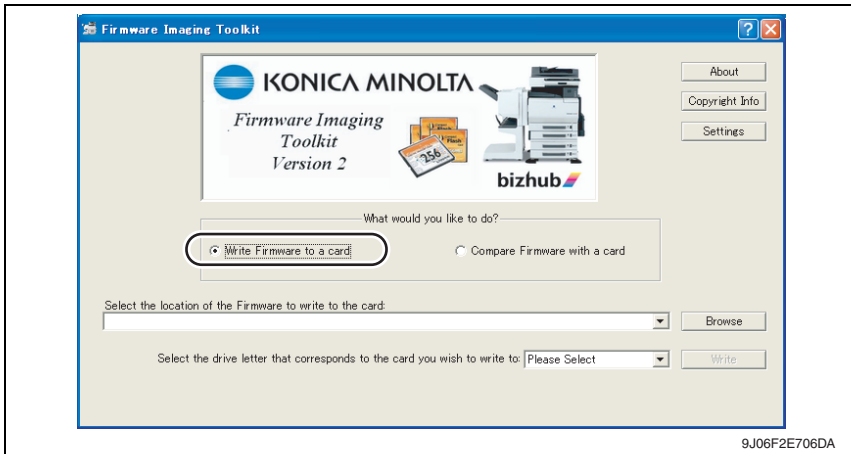

6. Click [Browse].

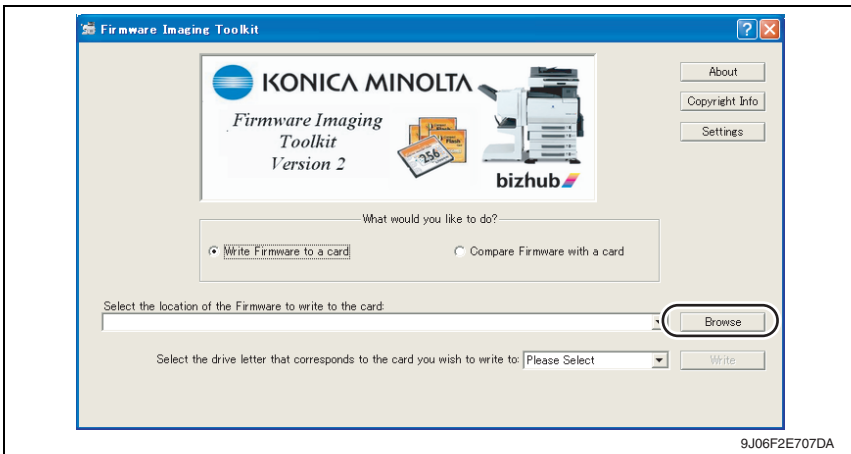

7. Select the file type [C353/C253/C203 Indexed Firmware].

8. Move to the folder decompressed at step 2, confirm that only “###\_cf.tar.gz” (### is for model name) is displayed, and select.

**NOTE**

- If the file extension is set to be not displayed in Windows, the file name “.gz” will not be displayed.

9. Click [Open].

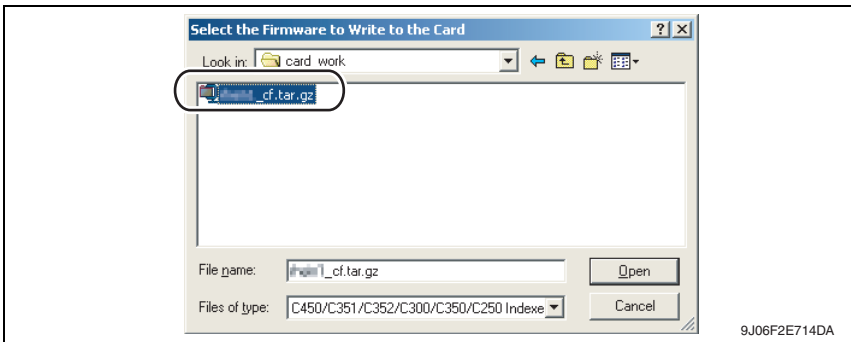

10. Select the drive that the compact flash is inserted, which is confirmed at step 3.

**NOTE**

- **The drives other than the compact flash that is recognized as “Removable Disk” can be selected for the writing destination. If these drives are selected mistakenly to make the writing, it may give fatal damage on Windows system or delete the saved data. Therefore pay close attention when selecting the drive.**

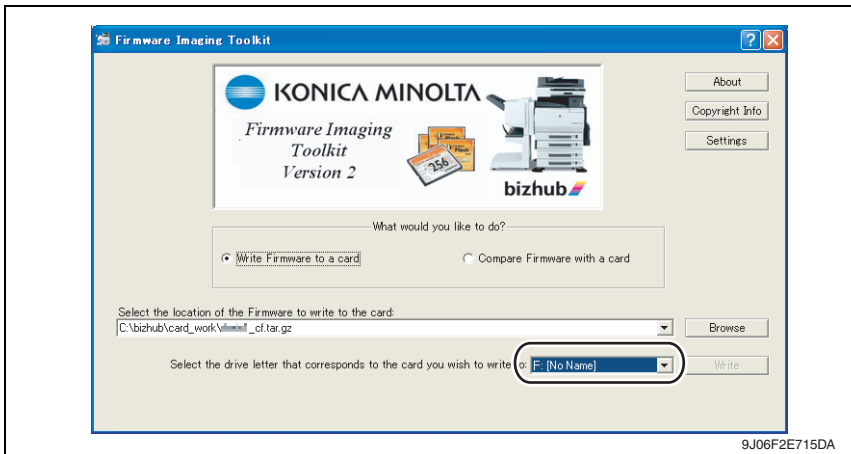

9J06F2E715DA

11. [Write] button is changed from gray into active status.

When clicking [Write] button, the following dialog is displayed.

12. In the dialog, re-confirm the firmware data and the written destination drive, and click [YES].

(If [NO] is clicked, the screen goes back of the main window.)

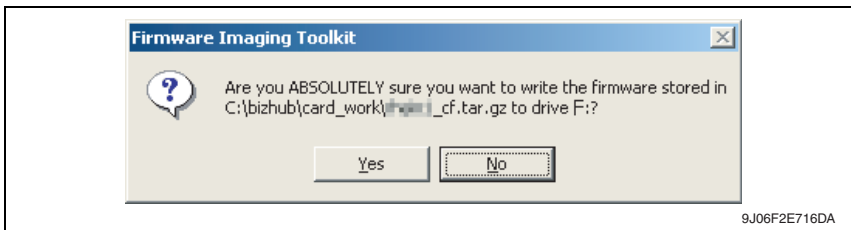

9J06F2E716DA

13. Click [Yes], and data writing starts.

**NOTE**

- **Writing a card is a resource intensive operation for your computer - do not attempt to multitask (use the computer for anything else) during the writing procedure.**

14. When the writing is completed, the following screen appears.

In this screen, check sums will be compared between the firmware data and one written into the compact flash.

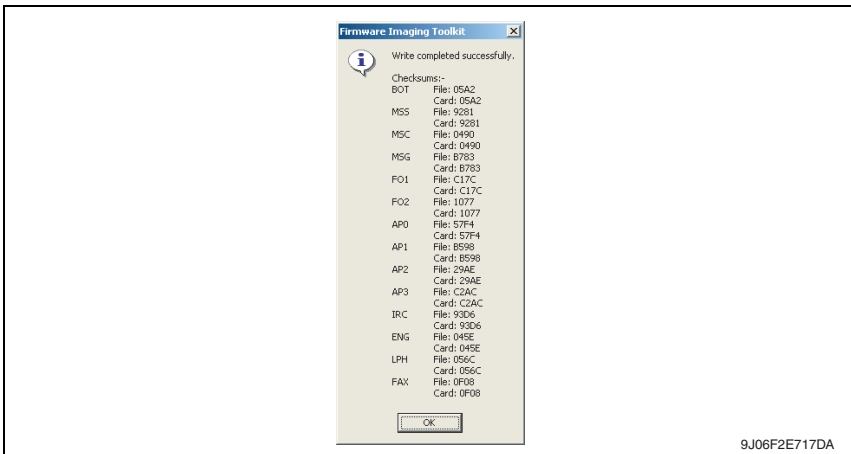

**NOTE**

- **The contents displayed on the screen may differ according to the model type. The above is the screen displayed for firmware data writing of bizhub C450.**

15. Confirm each check sums are identical and quit Firmware Imaging Toolkit 2006.

16. Take out the compact flash from the PC.

**NOTE**

- **When removing the compact flash, be sure to check if data is written as normal and then remove it according to the precise removing method.**

## 5.5 Firmware rewriting by compact flash

- The firmware is updated using the compact flash.

### 5.5.1 Updating method

#### NOTE

- **NEVER** remove or insert the compact flash card with the machine power turned ON.

1. Turn OFF the main power switch.
2. Open the rear right door.

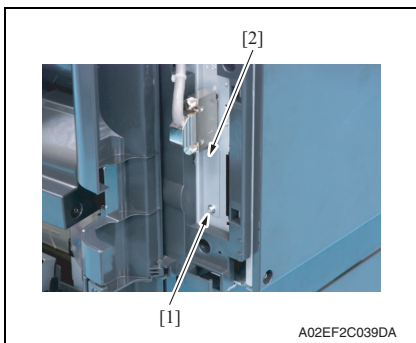

3. Remove the screw [1] and the metal blanking plate [2].

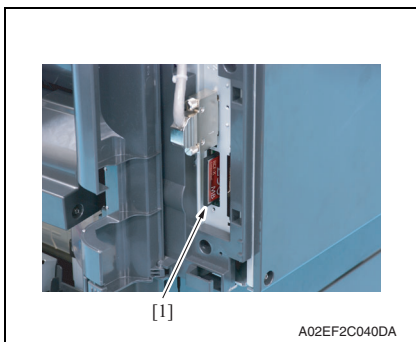

4. Insert the compact flash card [1] into the slot.

5. Turn ON the main power switch and the sub power switch.
6. Control panel shows F/W items to be updated.



7. Select the particular type of F/W to be updated. (Select [YES].)

**Firmware Update**    Please do not turn off the main SW and Sub-Power !!

---

<p><b>MFP CONTROLLER</b></p> <p><input type="checkbox"/> YES    <input type="checkbox"/> NO</p> <p><b>SCANNER</b></p> <p><input type="checkbox"/> YES    <input type="checkbox"/> NO</p> <p><b>PRINTER</b></p> <p><input type="checkbox"/> YES    <input type="checkbox"/> NO</p> <p><b>FAX BOARD CONTROLLER1</b></p> <p><input type="checkbox"/> YES    <input type="checkbox"/> NO</p>	<p><b>FAX BOARD CONTROLLER2</b></p> <p><input type="checkbox"/> YES    <input type="checkbox"/> NO</p> <p><b>ADF(DF-M)</b></p> <p><input type="checkbox"/> YES    <input type="checkbox"/> NO</p> <p><b>FINISHER</b></p> <p><input type="checkbox"/> YES    <input type="checkbox"/> NO</p>
--	---

A02EF2C522DA

F/W to be updated	Appropriate board
MFP CONTROLLER	MFP board (MFPB)
SCANNER	Image processing board (IPB)
PRINTER	Printer control board (PRCB)
FAX BOARD CONTROLLER1	Fax board (Main) *1
FAX BOARD CONTROLLER2	Fax board (Sub) *2
ADF (DF-M)	DF control board (DFCB)
FINISHER	FS control board (FSCB) *3

\*1: The optional fax kit is necessary for the above procedure.

\*2: The optional fax multi line ML-501 is necessary for the above procedure.

\*3: The optional finisher FS-519 or FS-609 is necessary for the above procedure.

8. Press the [START]. (At this time, the Start key starts blinking red.)
9. Check that the control panel shows the message indicating that the data has been rewritten correctly ([Downloading Completed]). Check also the check sum value ([Check Sum ####]) shown on the control panel. (The Start key blinks blue.)
10. Turn OFF the main power switch.
11. Remove the compact flash card from the slot.
12. Turn ON the main power switch, and close the front door.

**NOTE**

- When turning the main power switch ON for the first time after the firmware is updated, data may sometimes be internally updated. In that case, the following message will be displayed. Never turn the main power switch OFF until either the serial number input screen or the trouble code screen is displayed.

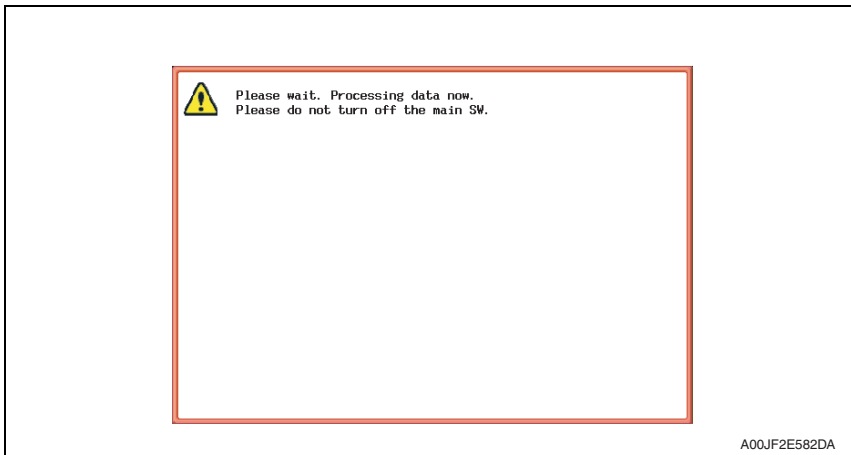

13. Call the Service Mode to the screen.
14. Select [Firmware Version].
15. Make sure if the version of firmware is updated.

**5.5.2 Action when data transfer fails**

- If “NG” appears on the control panel, indicating that rewriting has been unsuccessful (in which case the Start key lights up red), take the following steps.
  1. Perform the data rewriting procedure again.
  2. If the procedure is abnormally terminated, change the compact flash for a new one and try another rewriting sequence.
  3. If the procedure is still abnormally terminated, change the board that has caused “NG” and carry out data rewriting procedure.

MFP CONTROLLER	MFP board (MFPB)
SCANNER	Image processing board (IPB)
PRINTER	Printer control board (PRCB)
FAX BOARD CONTROLLER1	Fax board (Main) *1
FAX BOARD CONTROLLER2	Fax board (Sub) *2
ADF (DF-M)	DF control board (DFCB)
FINISHER	FS control board (FSCB) *3

\*1: The optional fax kit is necessary for the above procedure.

\*2: The optional fax multi line ML-501 is necessary for the above procedure.

 \*3: The optional finisher FS-519 or FS-609 is necessary for the above procedure.

## 5.6 Updating the firmware with the Internet ISW

### 5.6.1 Outline

- [Internet ISW] is the system which gives the instruction for updating the firmware with the control panel of the main body, so the main body will automatically receive the firmware from the program server over a network for updating. With the Internet ISW, the firmware can be updated when the CE is at the user's without firmware data.

### 5.6.2 Service environment

The following conditions are necessary for using the Internet ISW function.

- The main body is connected to such a network environment that the firmware can be downloaded on the internet using the ftp or http protocol.

The "Internet ISW" will not operate under the following conditions.

- Main power switch is set to OFF.
- Sub power switch is set to OFF.
- When the following setting is set to "ON":  
[Administrator Setting] → [Security Setting] → [Enhanced Security Mode]
- The main body has the job currently performing.

### 5.6.3 Preparations for firmware rewriting

- For using the Internet ISW, the network parameter, program server address as well as firewall address need to be set to the main body.
- For details of each setting item, refer to Adjustment/Setting "Internet ISW".

[See P.432](#)

#### A. Internet ISW Set

1. Call the Service Mode to the screen.
2. Touch [Internet ISW Set] which is available from [Internet ISW].

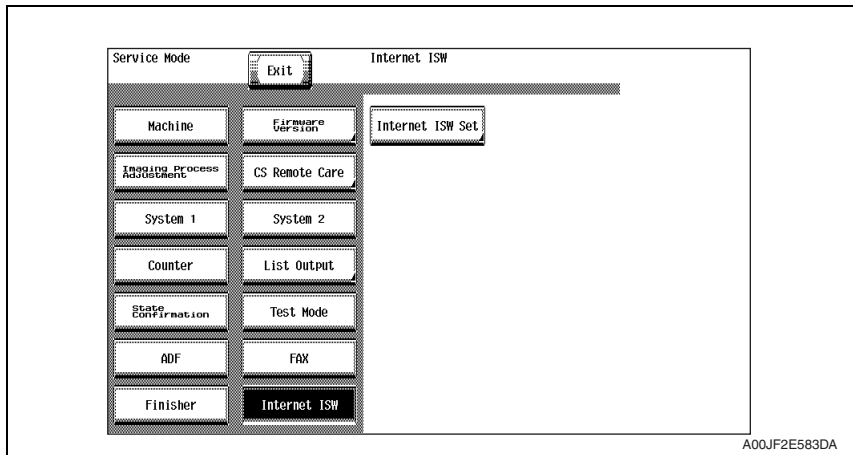

3. Touch [ON], and touch [END].

**NOTE**

- **Settings such as server setting, etc. will be available by selecting “ON” on this setting.**
- **When the following setting is set to “ON”, “ON” cannot be selected on this setting. [Administrator Setting] → [Security Setting] → [Enhanced Security Mode]**

**B. Protocol setting**

- **It performs the setting concerning the protocol (ftp or http) for connecting to the Internet ISW.**
- **When connecting to the program server using a proxy server, perform the setting for a proxy server.**

Step	Connecting by http	Connecting by ftp
0	Select [Internet ISW] which is available from [Service Mode].	
1	Data Input Setting • Touch [HTTP Setting], and select [ON].	Data Input Setting • Touch [FTP Setting], and select [ON].
2	Connect Proxy • For connecting via proxy server, select [ON].	
3	Proxy Server • For connecting via proxy server, set the proxy server address and the port number.  1. Select the [Server Address], and set the proxy server address by IP addressing scheme or FQDN scheme. 2. Select [Port Number], and set the port number for the proxy server from 1 through 65535.	
4	Proxy Authentication • Set the login name and the password which may be necessary for authentication when accessing to the proxy server.  1. When Authentication is necessary for accessing to the proxy server, select [Authentication], and select [ON]. 2. Select [Log-in Name], and enter the login name on the on-screen keyboard. 3. Select [Password], and enter the password on the on-screen keyboard.	Connection Setting • Perform the setting for accessing FTP server.  1. Select [Port Number], and set the port number for FTP server from 1 through 65535. 2. Select [Connection Time Out], and set the time for the connection time out from 1 through 60. 3. When connecting in PASV mode, select [PASV Mode], and select [ON].  *PASV Mode: This mode is for transferring the file with FTP under the condition where communication is restricted such as inside the firewall. Since with PASV mode, the client with restriction sets the port number, data transmission port can be secured to enable the file transmission.
5	Connection Time-Out • Select [Connection Time-Out], and set the time for the connection time out between 30 and 300 seconds.	—

**C. Forwarding access setting**

- To make the access setting for the program server which stores the firmware data.
1. Select [Internet ISW] which is available from [Service Mode].
  2. Touch [Forwarding Access Setting].

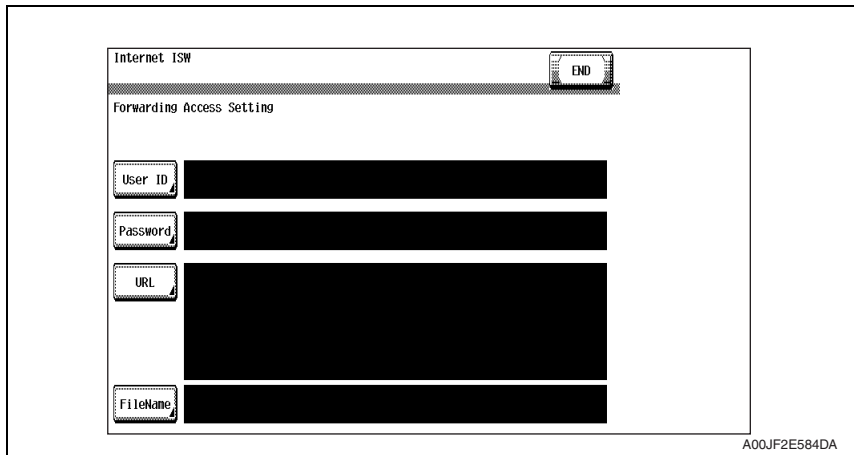

3. Select [User ID], and enter the user ID which is necessary for connecting to the program server on the on-screen keyboard, and touch [END].
4. Select [Password], and enter the password which is necessary for connecting to the program server on the on-screen keyboard, and touch [END].
5. Select [URL], and enter the directory which stores the program server address and the firmware on the on-screen keyboard by URL method, and touch [END].

**NOTE**

- Enter the URL which matches to the protocol to be used.
    - When connecting to http    **http://(host name or IP address)/directory name**
    - or    **https://(host name or IP address)/directory name**
    - When connecting to ftp        **ftp://(host name or IP address)/directory name**
6. Select [File Name], and enter the file name of the firmware data to be downloaded on the on-screen keyboard, and touch [END].
  7. Touch [END] to finish setting.

### 5.6.4 Firmware rewriting

#### NOTE

- When performing the Internet ISW, ask the administrator for permission beforehand.
- DO NOT turn OFF the main/sub power switch while downloading.

#### A. Conducting rewriting on the control panel.

1. Perform the following setting.  
[Service Mode] → [Internet ISW] → [Download]
2. Touch [ISW Start].

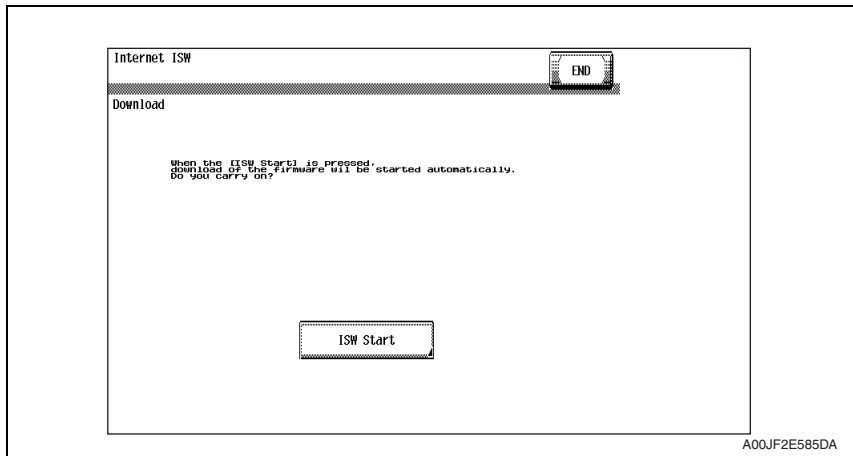

3. The main body will automatically start running, and it starts accessing the server.
4. Select the F/W to be updated, and start downloading.

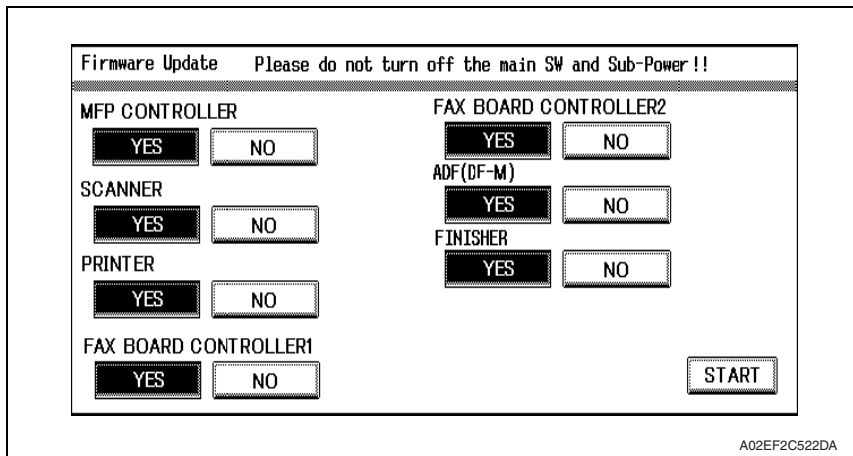

#### B. During firmware updating

1. The message to indicate the status will be displayed on the screen while connecting or transferring data.

**C. Completed or failed****(1) Firmware updated normally**

1. When the firmware is normally updated, restart the main body in auto or manual mode to display the outcome, and touch [OK] to return to the main screen.

**(2) Failing to update the firmware due to the network trouble**

1. When updating failed to complete due to the trouble on connecting to the network, an error code and the message will be displayed.
2. Restart the main body in auto or manual mode, and touch [OK]. It can be used with the firmware version before conducting updating.
3. Check the settings for the network by error codes, and try updating again.

**NOTE**

- For error codes, refer to “Error code list for the Internet ISW”.

[See P.75](#)

**(3) Failing to update the firmware after downloading has started**

1. Once firmware updating has started, the ROM in the main body will be deleted. When it failed right after updating has started, restart the main body, and shift to the standby screen to retry downloading.
2. When updating on the control panel, touch [settings] on the standby screen, and check the Network settings again. Touch [Download], and restart the Internet ISW.

**NOTE**

- Return to the standby screen without fail after turning the main power switch OFF/ON if the firmware is not updated.
- Firmware can be updated with the compact flash with the main power switch OFF.

**D. Confirming the firmware version**

1. Call the Service Mode to the screen.
2. Select the [Firmware Version].
3. Check if the firmware version is updated.

**5.6.5 Error code list for the Internet ISW**

- When a trouble occurred while conducting the Internet ISW and it was not normally connected, the message on the status and the error code will be displayed on the control panel.

When updating with CS Remote Care, the error code will be sent to the CS Remote Care center.

<Sample display>

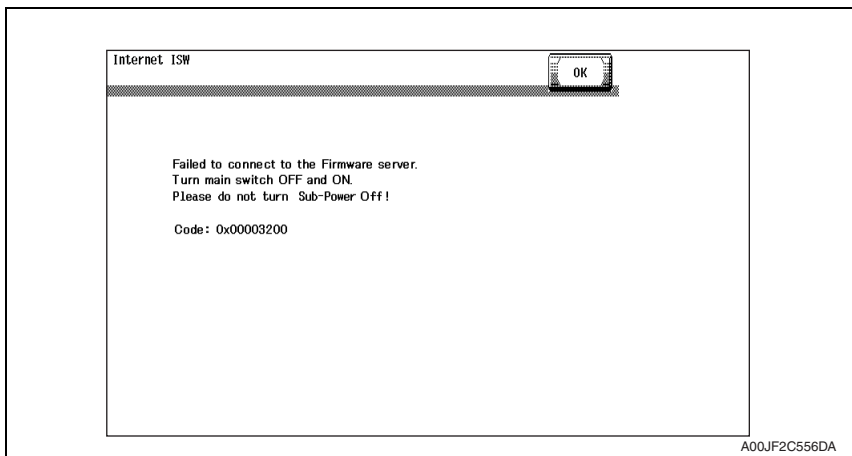

Error code	Description	Countermeasure
Control panel		
0x00000001	Illegal error on the control	<ul style="list-style-type: none"> <li>• Check if the following setting is set to "ON". [Service Mode] → [Internet ISW] → [Internet ISW Set]</li> <li>• Check the status of the following setting. [Service Mode] → [Internet ISW] → [Forwarding Access Setting]</li> <li>• If the above process does not solve the problem, inform the corresponding error code to the KMBT.</li> </ul>
0x00000010	Parameter error	<ul style="list-style-type: none"> <li>• Check if the following setting is set to "ON". [Service Mode] → [Internet ISW] → [Internet ISW Set]</li> <li>• If the above process does not solve the problem, inform the corresponding error code to KMBT.</li> </ul>



Error code	Description	Countermeasure
Control panel		
0x00111000	Error concerning the network • Connection has been completed.	<ul style="list-style-type: none"> <li>• Check the User's network environment. (LAN cable's connection)</li> <li>• Check the status of the following setting. [Service Mode] → [Internet ISW] → [Forwarding Access Setting]</li> <li>• Check to see if the FTP server operates normally.</li> </ul>
0x00111001	Error concerning the network • It cannot be connected to the server.	<ul style="list-style-type: none"> <li>• Check the network environment of the User.</li> <li>• Check to see if the FTP server operates normally.</li> </ul>
0x00111100	Error concerning the network • Communication timeout.	
0x00111101	Error concerning the network • Disconnection occurred	<ul style="list-style-type: none"> <li>• Check the network environment of the User.</li> <li>• Check to see if the FTP server operates normally.</li> </ul>
0x00111110	Error concerning the network • The network is not connected.	
0x00110010	Error concerning the network • Others	
0x00001###	FTP error • Reply code when it failed to be connected	<ul style="list-style-type: none"> <li>• Check to see if FTP server normally operates.</li> <li>• Check the IP address, user's name, etc.</li> </ul>
0x00002###	FTP error • Error reply code for the user command or pass command	<ul style="list-style-type: none"> <li>• Check to see if FTP server operates normally.</li> </ul>
0x00003###	FTP error • Error reply code for CWD command	
0x00004###	FTP error • Error reply code for the TYPE command.	<ul style="list-style-type: none"> <li>• Check to see if FTP server operates normally.</li> </ul>
0x00005###	FTP error • Error reply code for the PORT command.	
0x00006###	FTP error • Error reply code for the PASV command.	<ul style="list-style-type: none"> <li>• Check to see if FTP server operates normally.</li> <li>• Set the PASV mode to "OFF", and try it again.</li> </ul>
0x00007###	FTP error • Error rely code for the RETR command.	<ul style="list-style-type: none"> <li>• Check to see if FTP server operates normally.</li> <li>• Wait for about 30 minutes and try it again.</li> </ul>
0x1000 0100	<ul style="list-style-type: none"> <li>• It cannot be accepted because of the job currently being executed.</li> <li>• ISW being executed by other method.</li> </ul>	<ul style="list-style-type: none"> <li>• Wait for the current job to be completed and try it again.</li> </ul>
0x10000101	<ul style="list-style-type: none"> <li>• It cannot be accepted because the sub power switch is OFF.</li> </ul>	<ul style="list-style-type: none"> <li>• Turn sub power switch ON and try it again.</li> </ul>
0x10000102	<ul style="list-style-type: none"> <li>• The Internet ISW is already being executed.</li> </ul>	<ul style="list-style-type: none"> <li>• Wait for the current Internet ISW to be completed.</li> </ul>

Error code	Description	Countermeasure
Control panel		
0x10000103	<ul style="list-style-type: none"> <li>It failed to prohibit the job. (It failed to lock the operation.) → It failed to lock the job because the operation is already locked with PSWC, etc.</li> </ul>	<ul style="list-style-type: none"> <li>Check if the following setting is set to "ON". [Service Mode] → [Internet ISW] → [Internet ISW Set]</li> <li>If the above process does not solve the problem, inform the corresponding error code to the KMBT.</li> </ul>
0x10000104	<ul style="list-style-type: none"> <li>There is no space for F/W data to be downloaded.</li> </ul>	
0x10000106	<ul style="list-style-type: none"> <li>Check sum error</li> </ul>	
0x10000107	<p>File access error</p> <ul style="list-style-type: none"> <li>The file downloaded has an error.</li> <li>The header of the file which has been read has an error.</li> <li>The size of the file to be downloaded is too large.</li> <li>When it is identified to be the different type of F/W.</li> </ul>	<ul style="list-style-type: none"> <li>Check to see if the downloaded F/W is of the correct type.</li> </ul>
0x10000108	<ul style="list-style-type: none"> <li>The area F/W is stored is destroyed, and another ISW is necessary.</li> </ul>	<ul style="list-style-type: none"> <li>Wait until ISW is automatically executed on MFP side.</li> </ul>
0x20000000	<p>The temporary error when running the subset</p> <ul style="list-style-type: none"> <li>When starting the Internet ISW in a normal program, the rebooting will start and the Internet ISW will be executed with the subset program. During the process by the subset program, it has to be in the "Failed" status unless the Internet ISW is successfully conducted. This code is used temporarily to make it in error status.</li> </ul>	

## 6. Other

### 6.1 Disassembly/adjustment prohibited items

#### A. Paint-locked screws

##### NOTE

- To prevent loose screws, a screw lock in blue or green series color is applied to the screws.
- The screw lock is applied to the screws that may get loose due to the vibrations and loads created by the use of machine or due to the vibrations created during transportation.
- If the screw lock coated screws are loosened or removed, be sure to apply a screw lock after the screws are tightened.

#### B. Red-painted screws

##### NOTE

- The screws which are difficult to be adjusted in the field are painted in red in order to prevent them from being removed by mistake.
- Do not remove or loosen any of the red-painted screws in the field. It should also be noted that, when two or more screws are used for a single part, only one representative screw may be marked with the red paint.

#### C. Variable resistors on board

##### NOTE

- Do not turn the variable resistors on boards for which no adjusting instructions are given in Adjustment/Setting.

#### D. Removal of PWBs

##### CAUTION

- When removing a circuit board or other electrical component, refer to “Handling of PWBs” and follow the corresponding removal procedures.
- The removal procedures given in the following omit the removal of connectors and screws securing the circuit board support or circuit board.
- Where it is absolutely necessary to touch the ICs and other electrical components on the board, be sure to ground your body.

## 6.2 Disassembly/assembly/cleaning list (other parts)

### 6.2.1 Disassembly/assembly parts list

No.	Section	Part name	Ref. page
1	Exterior parts	Front door	<a href="#">P.82</a>
2		Upper front cover/1	<a href="#">P.83</a>
3		Upper front cover/2	<a href="#">P.84</a>
4		Right front cover/1	<a href="#">P.84</a>
5		Right front cover/2	<a href="#">P.85</a>
6		Left cover	<a href="#">P.86</a>
7		Rear left cover/1	<a href="#">P.87</a>
8		Rear left cover/2	<a href="#">P.87</a>
9		Exit cover	<a href="#">P.88</a>
10		Paper exit rear cover	<a href="#">P.88</a>
11		IR rear cover	<a href="#">P.89</a>
12		IR right cover	<a href="#">P.89</a>
13		IR upper rear cover/1	<a href="#">P.89</a>
14		IR upper rear cover/2	<a href="#">P.89</a>
15		IR upper rear cover/3	<a href="#">P.89</a>
16		IR left cover	<a href="#">P.89</a>
17		IR upper front cover	<a href="#">P.89</a>
18		IR front cover	<a href="#">P.90</a>
19		Original glass	<a href="#">P.90</a>
20		Rear right cover/1	<a href="#">P.91</a>
21		Rear right cover/2	<a href="#">P.91</a>
22		Rear right cover/3	<a href="#">P.91</a>
23		Manual bypass tray front cover	<a href="#">P.92</a>
24		Manual bypass tray rear cover	<a href="#">P.92</a>
25		Upper rear cover	<a href="#">P.92</a>
26		Rear cover/1	<a href="#">P.92</a>
27		Rear cover/2	<a href="#">P.92</a>
28		Lower rear cover/1	<a href="#">P.93</a>
29		Lower rear cover/2	<a href="#">P.93</a>
30		Vertical transport door	<a href="#">P.93</a>
31		Control panel assy	<a href="#">P.93</a>
32		Exit tray	<a href="#">P.94</a>
33		Tray 1	<a href="#">P.95</a>
34		Tray 2	<a href="#">P.95</a>
35		Front cover	<a href="#">P.96</a>

No.	Section	Part name	Ref. page	
36	Units	PH unit	<a href="#">P.98</a>	
37		Manual bypass tray unit	<a href="#">P.103</a>	
38		CCD unit	<a href="#">P.104</a>	
39		Original glass moving unit	<a href="#">P.106</a>	
40		Glass step sheet	<a href="#">P.109</a>	
41		Scanner assy	<a href="#">P.111</a>	
42		Hard disk drive	<a href="#">P.113</a>	
43		Main drive unit	<a href="#">P.113</a>	
44		Transport drive unit	<a href="#">P.115</a>	
45		Fusing drive unit	<a href="#">P.119</a>	
46		Hopper drive unit (C/K, Y/M)	<a href="#">P.121</a>	
47		Right door assy	<a href="#">P.122</a>	
48		IR Assy	<a href="#">P.125</a>	
49		PWBs	Scanner relay board (REYB/SCAN)	<a href="#">P.127</a>
50	Original glass position control board (OGPCB)		<a href="#">P.128</a>	
51	Inverter board (INVB)		<a href="#">P.129</a>	
52	Image processing board (IPB)		<a href="#">P.130</a>	
53	PH relay board (REYB/PH)		<a href="#">P.132</a>	
54	DC power supply (DCPU)		<a href="#">P.134</a>	
55	Printer control board (PRCB)		<a href="#">P.136</a>	
56	MFP board (MFPB)		<a href="#">P.138</a>	
57	High voltage unit (HV)		<a href="#">P.142</a>	
58	Service EEPROM board (SV ERB)		<a href="#">P.143</a>	
59	SODIMM/1, SODIMM/2		<a href="#">P.145</a>	
60	JMP board (JMPB)		<a href="#">P.145</a>	
61	NVRAM board (NRB)		<a href="#">P.146</a>	
62	Machine condition monitor board (MCMB)		<a href="#">P.146</a>	
63	Paper feed tray 1 paper FD size detect board (PSDTB/1)		<a href="#">P.147</a>	
64	Paper feed tray 2 paper FD size detect board (PSDTB/2)		<a href="#">P.148</a>	
65	Motors		Scanner motor (M201)	<a href="#">P.149</a>
66			Original glass moving motor (M202)	<a href="#">P.152</a>
67		Duplex transport motor (M7)	<a href="#">P.153</a>	
68		Transport motor (M1)	<a href="#">P.154</a>	
69		Color PC motor (M2)	<a href="#">P.154</a>	
70		Fusing motor (M5)	<a href="#">P.155</a>	
71		Switchback motor (M6)	<a href="#">P.156</a>	
72		Fusing retraction motor (M12)	<a href="#">P.157</a>	
73		Paper feed tray 1 lift-up motor (M8)	<a href="#">P.158</a>	
74		Paper feed tray 2 lift-up motor (M9)	<a href="#">P.159</a>	
75		Toner supply motor/CK (M3)	<a href="#">P.161</a>	
76		Toner supply motor/YM (M4)	<a href="#">P.161</a>	



No.	Section	Part name	Ref. page
77	Clutches	Paper feed tray 1 paper feed clutch (CL1)	<a href="#">P.162</a>
78		Paper feed tray 2 vertical transport clutch (CL3)	<a href="#">P.163</a>
79		Paper feed tray 2 paper feed clutch (CL2)	<a href="#">P.164</a>
80		Manual paper feed clutch (CL4)	<a href="#">P.164</a>
81		Transfer belt retraction clutch (CL7)	<a href="#">P.165</a>
82		Developing clutch/K (CL5)	<a href="#">P.165</a>
83		Tim. roller clutch (CL6)	<a href="#">P.166</a>
84	etc.	IDC registration sensor/MK (IDCS/MK)	<a href="#">P.167</a>
85		IDC registration sensor/YC (IDCS/YC)	<a href="#">P.167</a>
86		Scanner drive cables	<a href="#">P.169</a>

### 6.2.2 Cleaning parts list

No.	Section	Part name	Ref. page
1	Processing section	Transfer belt unit	<a href="#">P.180</a>
2		PH window	<a href="#">P.180</a>
3	Tray 1	Tray 1 feed roller	<a href="#">P.181</a>
4		Tray 1 pick-up roller	<a href="#">P.181</a>
5		Tray 1 separation roller	<a href="#">P.181</a>
6	Tray 2	Tray 2 feed roller	<a href="#">P.182</a>
7		Tray 2 pick-up roller	<a href="#">P.182</a>
8		Tray 2 separation roller	<a href="#">P.182</a>
9		Tray 2 transport roller	<a href="#">P.183</a>
10	Manual bypass tray	Manual bypass tray feed roller	<a href="#">P.183</a>
11		Manual bypass tray separation roller	<a href="#">P.183</a>
12	Scanner section	Original glass	<a href="#">P.184</a>
13		Scanner rails	<a href="#">P.184</a>
14		Mirrors (1st/2nd/3rd)	<a href="#">P.185</a>
15		Lens	<a href="#">P.185</a>
16		CCD sensor	<a href="#">P.186</a>

### 6.3 Disassembly/assembly procedure

#### 6.3.1 Front door

1. Open the front door.

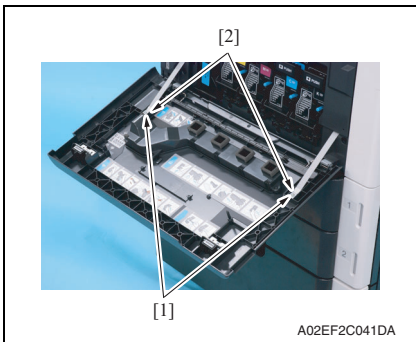

2. Remove two screws [1] and two suppression plates [2].

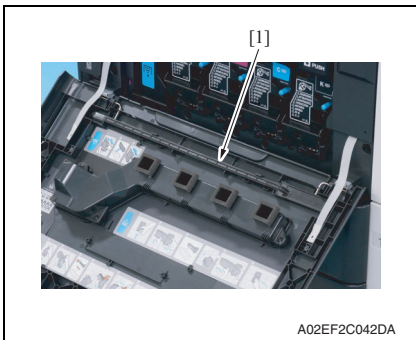

3. Remove the PH window cleaning jig [1].

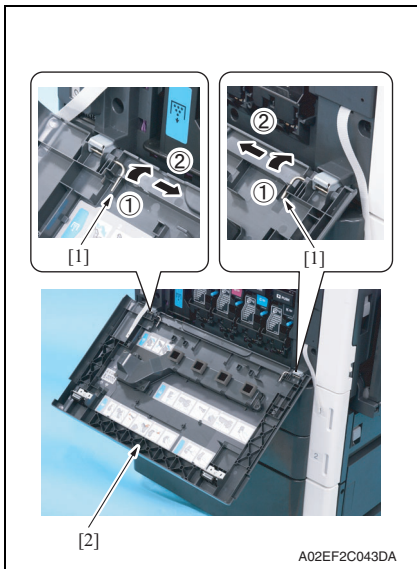

- 4. Slide two pins [1] in the direction of the arrow and remove it.
- 5. Remove the front door [2].

### 6.3.2 Upper front cover/1

- 1. Open the front door.
- 2. Remove the IR left cover.  
[See P.89](#)
- 3. Remove the IR right cover.  
[See P.89](#)
- 4. Remove the IR upper front cover.  
[See P.89](#)

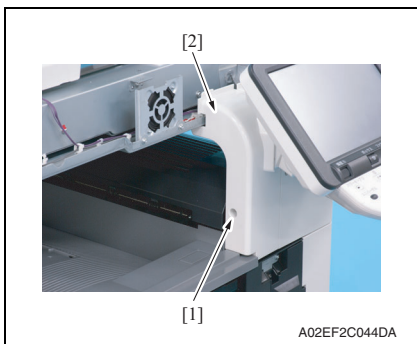

- 5. Remove the screw [1], and remove the upper front cover/1 [2].



### 6.3.3 Upper front cover/2

1. Open the right door.
2. Remove the upper front cover/1.  
See P.83

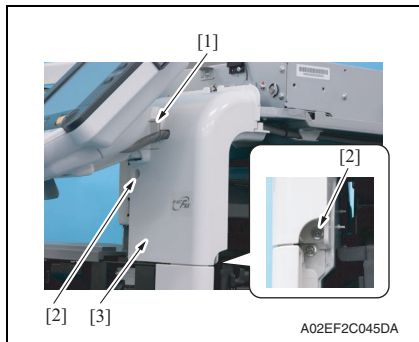

3. Remove the harness cover [1].
4. Remove two screws [2], and remove the upper front cover/2 [3].

### 6.3.4 Right front cover/1

1. Open the right cover.
2. Remove the upper front cover/2.  
See P.84

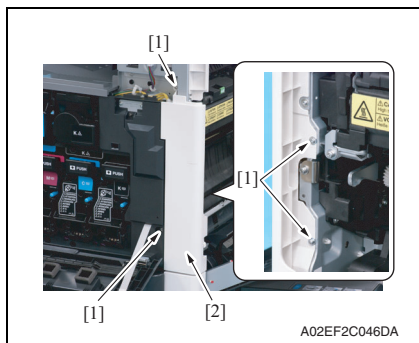

3. Remove four screws [1], and remove the right front cover/1 [2].

### 6.3.5 Right front cover/2

1. Slide out the tray 1 and tray 2.
2. Remove the right front cover/1.

See P.84

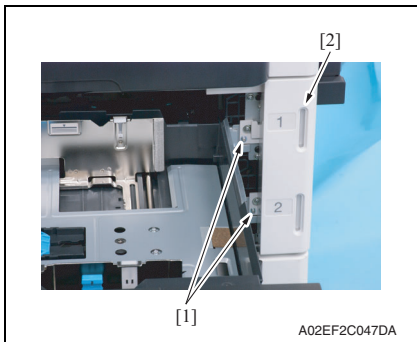

3. Remove two screws [1], and remove the right front cover/2 [2].

#### NOTE

- Do not remove it in rush as it is connected to the harness.

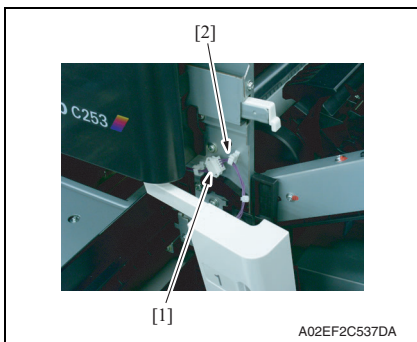

4. Disconnect the connector [1], and remove the harness from the wire saddle [2].

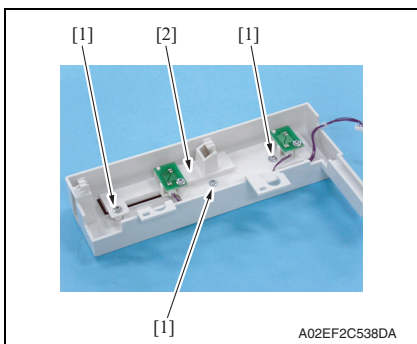

5. Remove three screw [1], and remove the paper empty indicator board assy [2].

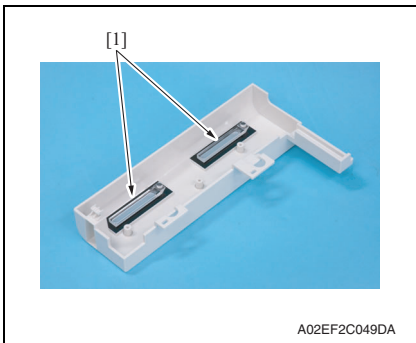

- Remove two empty display lenses [1].

### 6.3.6 Left cover

- Open the front door.

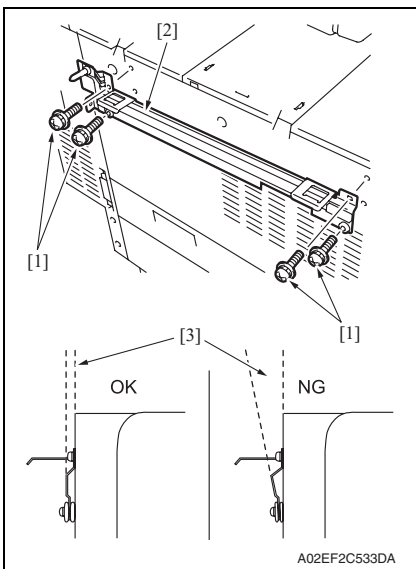

- If the optional finisher FS-519 is mounted, remove it.  
[See P.28 of the FS-519/PK-515/OT-602 service manual.](#)

#### NOTE

- After removing the finisher FS-519, remove four screws [1] and mounting plate [2].
- When reinstalling the mounting plate, do not secure two lower screws too tight, and make sure that the plate and the main unit will be parallel and the clearance [3] between those two will be even.

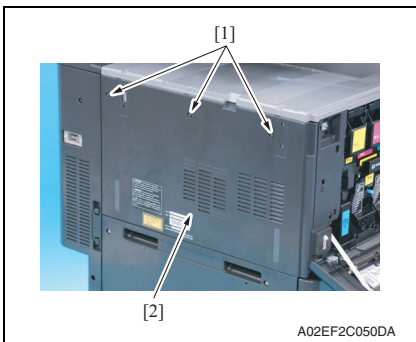

- Remove three screws [1], and remove the left cover [2].

**6.3.7 Rear left cover/1**

- 1. Open the front door.
- 2. Remove the ozone filter.  
[See P.41](#)
- 3. Remove the left cover.  
[See P.86](#)

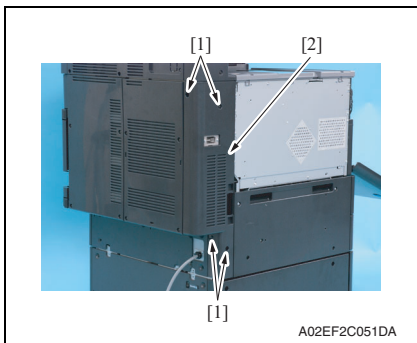

- 4. Remove four screws [1], and remove the rear left cover/1 [2].

**6.3.8 Rear left cover/2**

- 1. Remove the rear left cover/1.  
[See P.87](#)

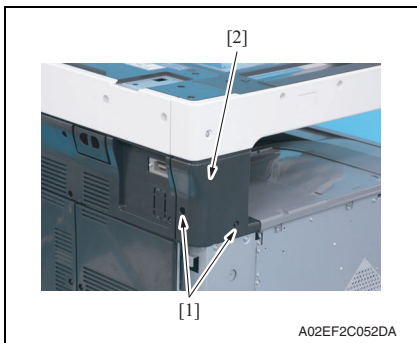

- 2. Remove two screws [1], and remove the rear left cover/2 [2].

### 6.3.9 Exit cover

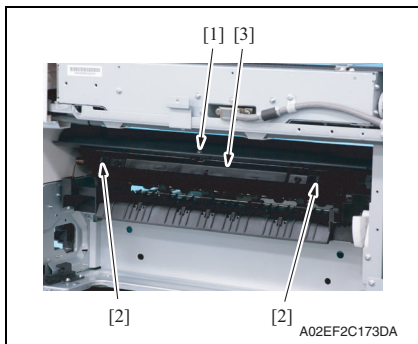

1. Remove the screw [1], unhook two tabs [2], and remove the paper exit cover [3].

### 6.3.10 Paper exit rear cover

1. Remove the rear left cover/2.  
[See P.87](#)
2. Remove the rear right cover/1.  
[See P.91](#)
3. Remove the exit tray.  
[See P.94](#)
4. Remove the exit cover.  
[See P.88](#)

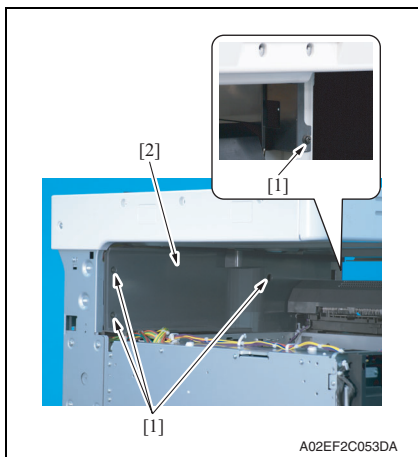

5. Remove four screws [1], and remove the paper exit rear cover [2].

### 6.3.11 IR rear cover, IR right cover, IR upper rear cover/1, IR upper rear cover/2, IR upper rear cover/3

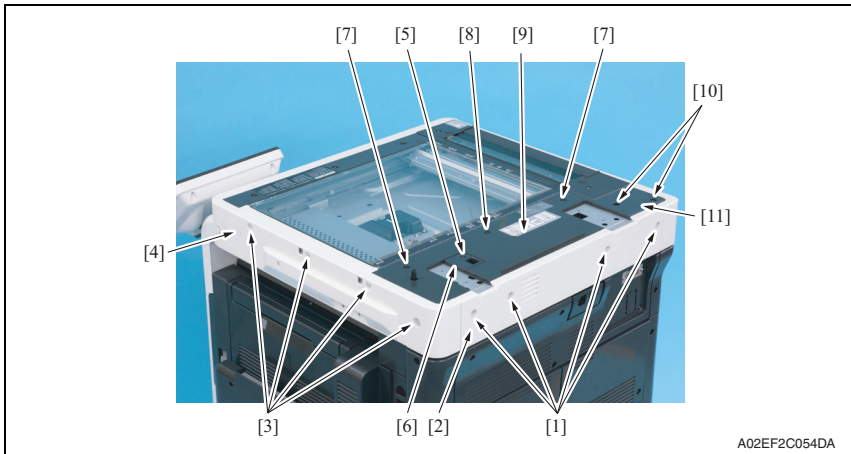

1. Remove four screws [1], and remove the IR rear cover [2].
2. Remove four screws [3], and remove the IR right cover [4].
3. Remove the screw [5], and remove the IR upper rear cover/3 [6].
4. Remove two shoulder screws [7] and the screw [8], and remove the IR upper rear cover/1 [9].
5. Remove two screws [10], and remove the IR upper rear cover/2 [11].

### 6.3.12 IR left cover, IR upper front cover

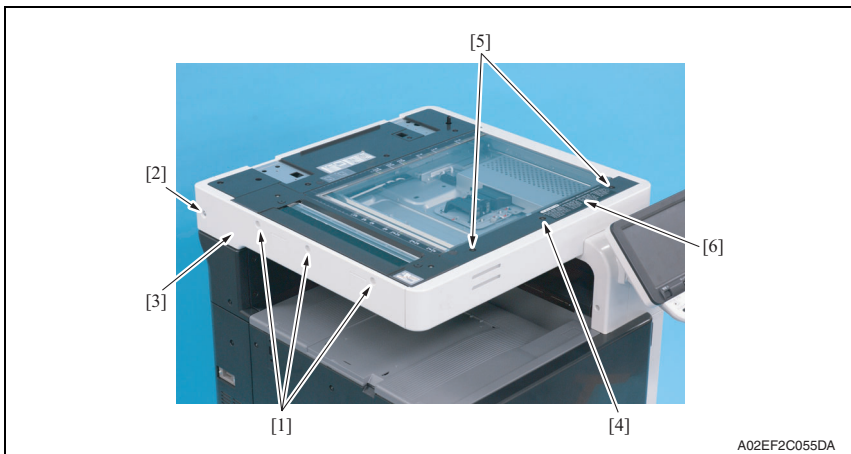

1. Remove three screws [1] and the shoulder screw [2], and remove the IR left cover [3].
2. Remove the screw [4] and two shoulder screws [5], and remove the IR upper front cover [6].

### 6.3.13 IR front cover

1. Remove the IR left cover.  
[See P.89](#)
2. Remove the IR right cover.  
[See P.89](#)
3. Remove the IR upper front cover.  
[See P.89](#)

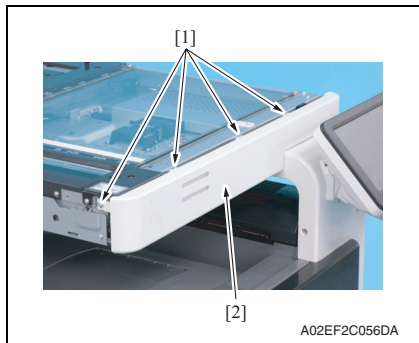

4. Remove four screws [1], and remove the IR front cover [2].

#### NOTE

- Do not remove it in rush as it is connected to the harness.

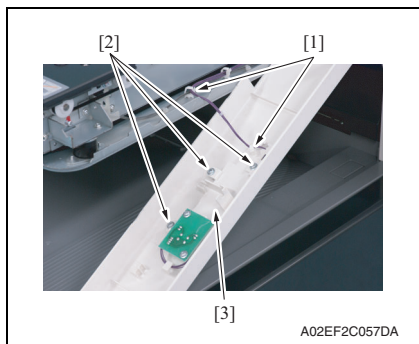

5. Remove the harness from two wire saddles [1].
6. Remove three screws [2], and remove the machine condition monitor board assembly [3].
7. Remove two display lenses.

### 6.3.14 Original glass

1. Remove the IR right cover.  
[See P.89](#)

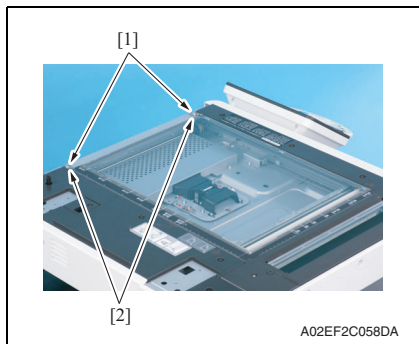

2. Remove each screw [1], and remove two original glass fixing brackets [2].

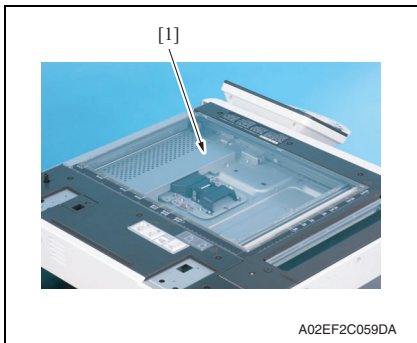

3. Remove the original glass [1].

### 6.3.15 Rear right cover/1, rear right cover/2, rear right cover/3

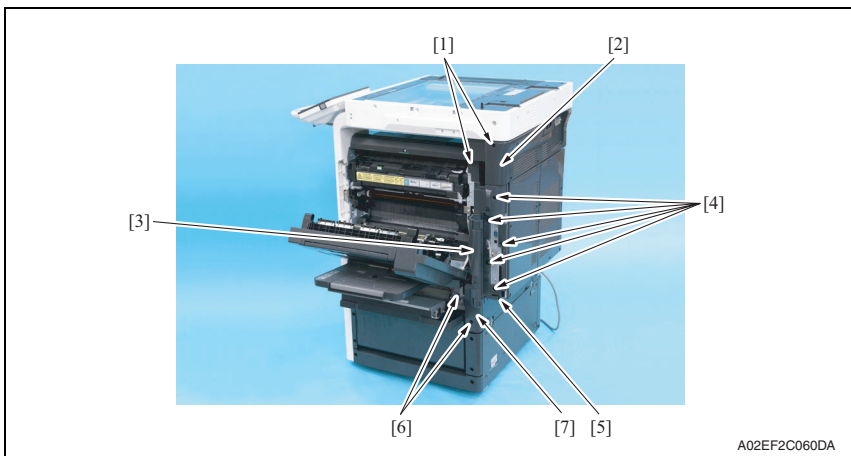

1. Open the right door.
2. Remove two screws [1], and remove the rear right cover/1 [2].
3. Open the rear right door [3], remove five screws [4], and remove the rear right cover/2 [5].
4. Remove two screws [6], and remove the rear right cover/3 [7].



### 6.3.16 Manual bypass tray front cover, manual bypass tray rear cover

1. Open the vertical transport door.
2. Remove the rear right cover/3.

See P.91

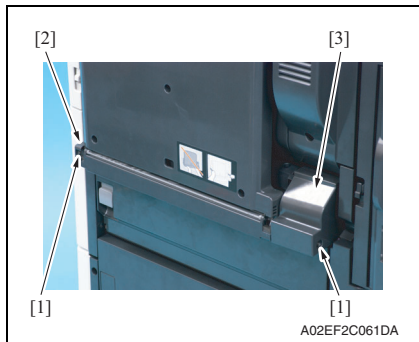

3. Remove two screws [1], and remove the manual bypass tray front cover [2] and the manual bypass tray rear cover [3].

### 6.3.17 Upper rear cover, rear cover/1, rear cover/2

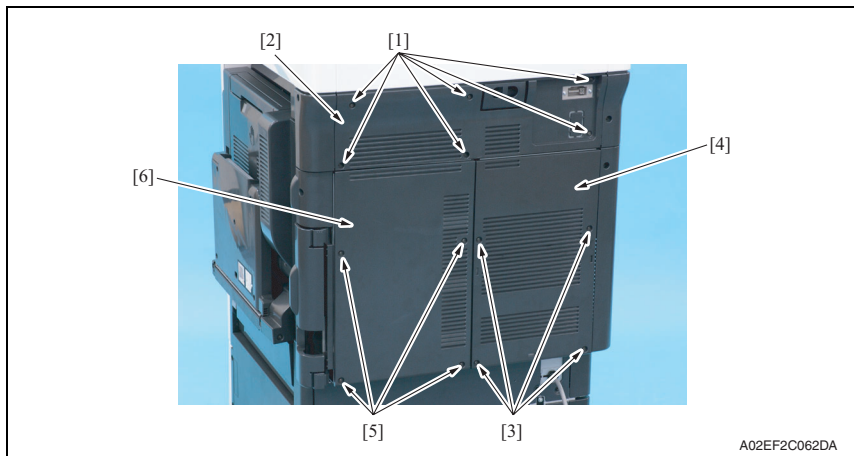

1. Remove six screws [1], and remove the upper rear cover [2].
2. Remove four screws [3], and remove the rear cover/2 [4].
3. Remove four screws [5], and remove the rear cover/1 [6].

### 6.3.18 Lower rear cover/1, lower rear cover/2

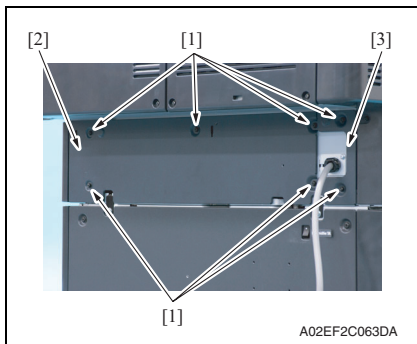

1. Remove seven screws [1], and remove the lower rear cover/1 [2] and the lower rear cover/2 [3].

### 6.3.19 Vertical transport door

1. Open the vertical transport door.

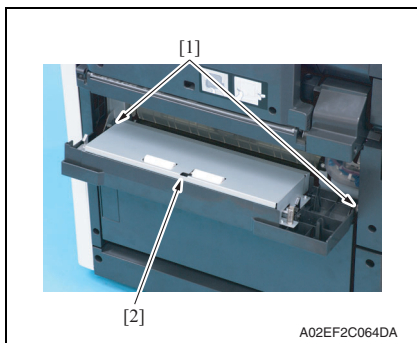

2. Unhook two tabs [1], and remove the vertical transport door [2].

### 6.3.20 Control panel assy (UN201)

1. Remove the upper front cover/1.  
[See P.83](#)
2. Remove the upper front cover/2.  
[See P.84](#)

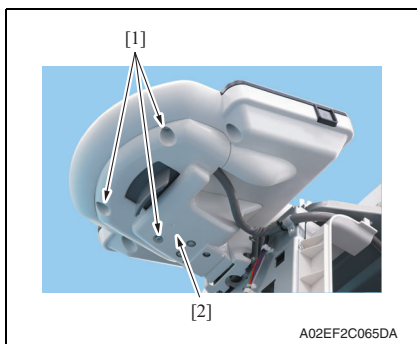

3. Remove three screws [1], and remove the control panel support cover [2].

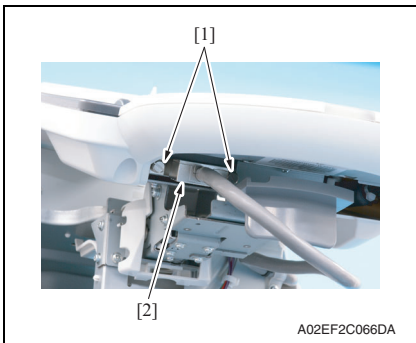

4. Remove two screws [1], and disconnect the connector [2].

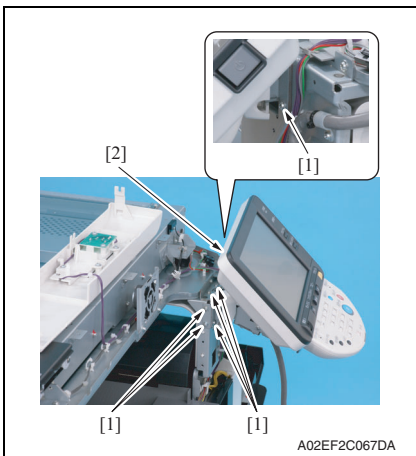

5. Remove six screws [1], and remove the control panel assy [2].

### 6.3.21 Exit tray

1. Open the front door.
2. Remove the left cover.  
[See P.86](#)

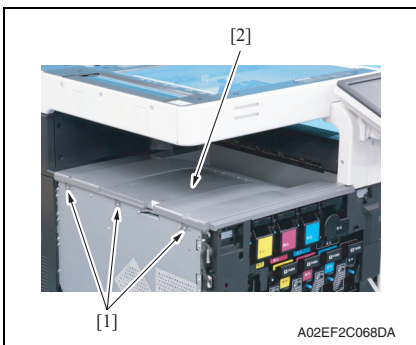

3. Remove three screws [1], and remove the exit tray [2].

### 6.3.22 Tray 1

1. Slide out the tray 1.

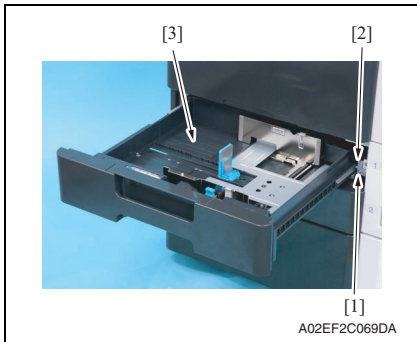

2. Remove the screw [1] and metal plate [2], and remove the tray 1 [3].

### 6.3.23 Tray 2

1. Slide out the tray 1 and tray 2.
2. Remove the right front cover/2.  
[See P.85](#)

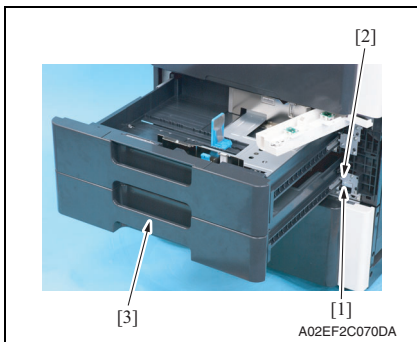

3. Remove the screw [1] and metal plate [2], and remove the tray 2 [3].

### 6.3.24 Front cover

1. Slide out the tray 1.
2. Remove the front door.  
[See P.82](#)
3. Remove the left cover.  
[See P.86](#)
4. Remove the toner cartridges (C, M, Y, K).  
[See P.41](#)
5. Remove the waste toner box.  
[See P.35](#)
6. Remove the imaging units (C, M, Y, K).  
[See P.37](#)
7. Remove the right front cover/2.  
[See P.85](#)

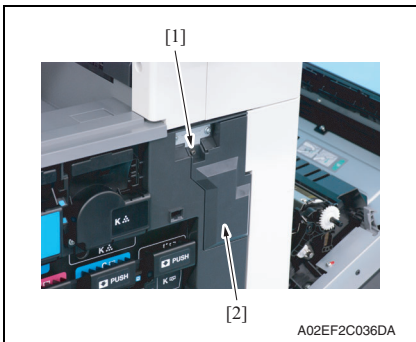

8. Remove the screw [1], and remove the connector protective cover [2].

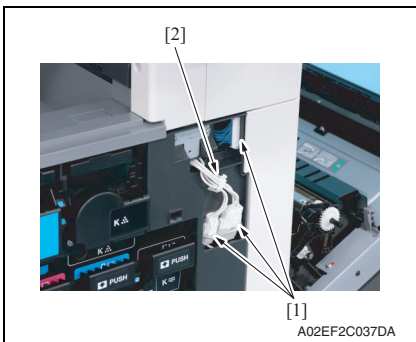

9. Disconnect three connectors [1], and remove the harness from the wire saddle [2].

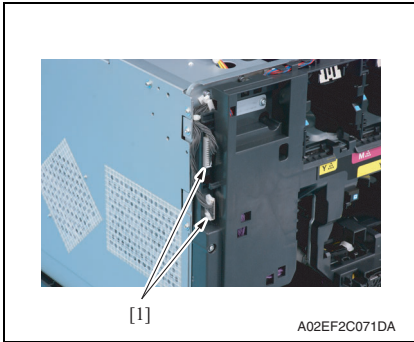

10. Disconnect two connectors [1].

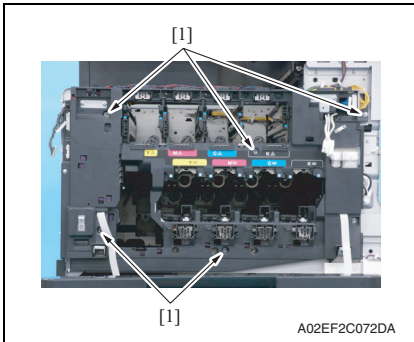

11. Remove five screws [1].

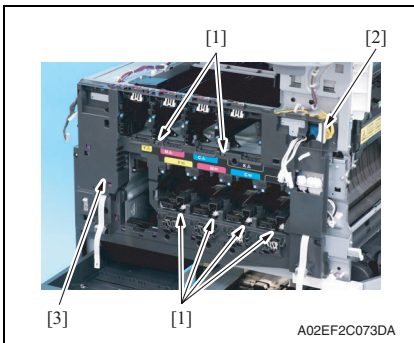

12. Unhook six tabs [1], and disconnect the connector [2] from the front cover.

13. Remove the front cover [3].

### 6.3.25 PH unit

#### CAUTION



- Do not replace the printer head unit while the power is ON. Laser beam generated during the above mentioned activity may cause blindness.



- Do not disassemble or adjust the printer head unit. Laser beam generated during the above mentioned activity may cause blindness.

#### NOTE

- When replace the PH unit, replace 4-color PH units at the same time.

#### A. Removal procedure

1. Remove the front cover.  
[See P.96](#)
2. Remove the transfer belt unit.  
[See P.43](#)

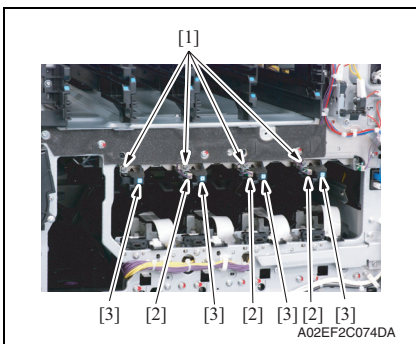

3. Remove four screws [1] and disconnect three connectors [2], and remove four imaging unit guide rails [3].

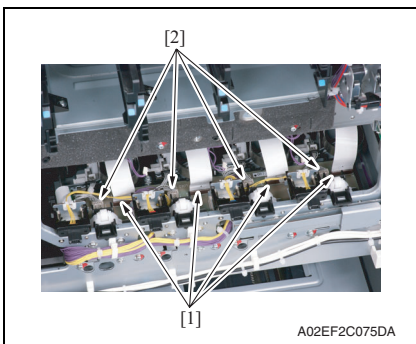

4. Disconnect four flat cables [1] and four connectors [2] of the PH unit.

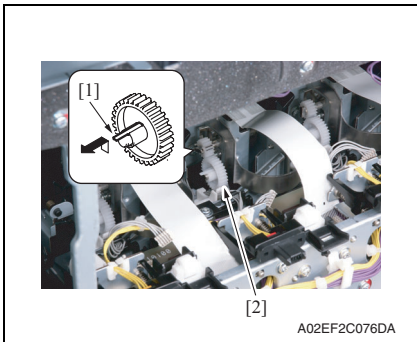

A02EF2C076DA

5. Unhook the tab [1], and remove the gear [2] of the PH unit.

**NOTE**

- This step is not needed when removing PH unit (Black) that does not have a gear.

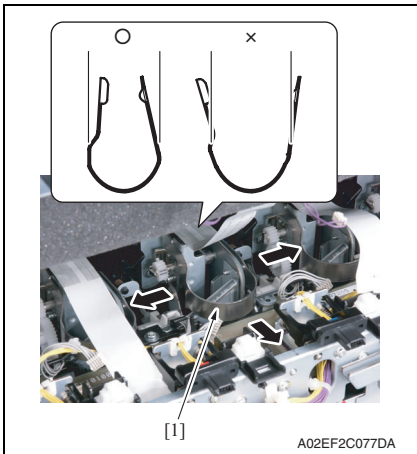

A02EF2C077DA

6. Remove the stopper [1] of the PH unit.

**NOTE**

- When removing the stopper, use care so that both ends of the stopper will not open but stay parallel as shown on the left. Keep using the stopper after once stretched out may cause uneven pitch or other image troubles.

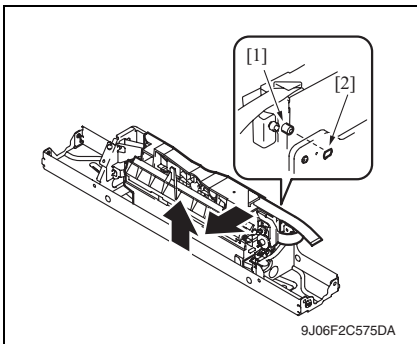

9J06F2C575DA

7. Remove the PH unit.

Move the front side of the PH unit to left a little, and remove the boss [1] from the locating hole [2].  
Lift up the front side of the PH unit a little.



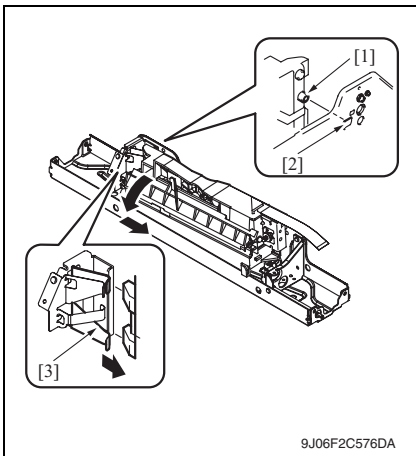

Remove the boss [1] at the rear side of the PH unit from the locating hole [2].

**NOTE**

- Since the back of the PH unit is pushed to the right with the two plate springs [3], remove it by tilting the backside of the PH unit to the left as shown in the left illustration.

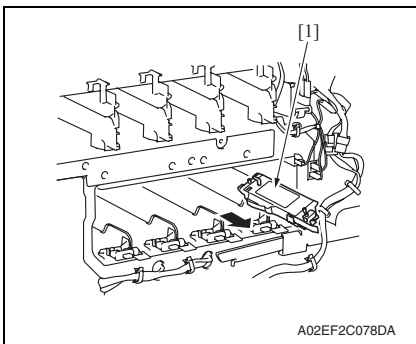

**Remove the PH unit [1].**

8. Follow the same procedures to remove all PH units.

**B. Reinstall procedure**

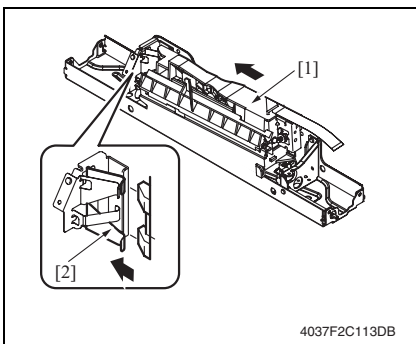

7. Fit the back of the PH unit [1] into the plate spring [2] of installation plate.

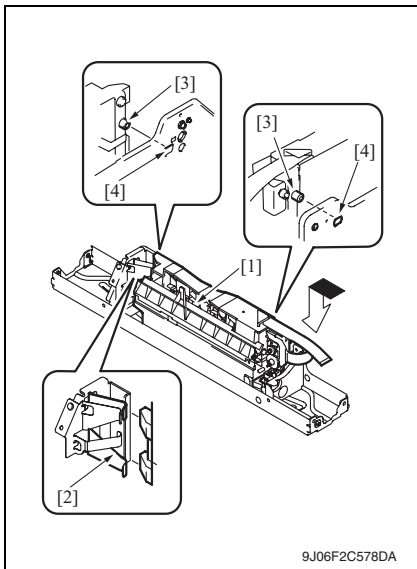

2. Push the PH unit [1] along the right side line of PH unit installation plate all the way and fit it into the plate spring [2].
3. Make sure that the two bosses [3] at front and rear side of the PH unit fit in two locating holes [4].

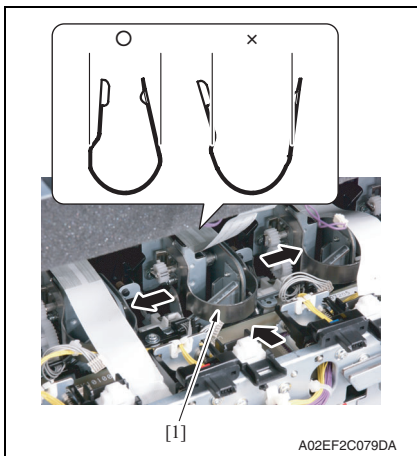

4. Reinstall the stopper [1].
- NOTE**
- When reinstalling the stopper, use care so that both ends of the stopper will not open but stay parallel as shown on the left. Keep using the stopper after once stretched out may cause uneven pitch or other image troubles.

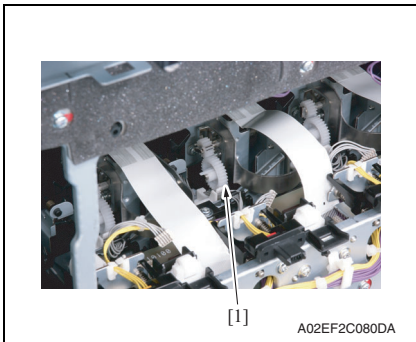

5. Reinstall the gear [1].

**NOTE**

- **Make sure that the gear claw is fit in.**
6. Connect the connector and the flat cable.

**NOTE**

- **Make sure the harness is installed along with the harness guide.**
7. Follow the same procedures to install all the PH units.

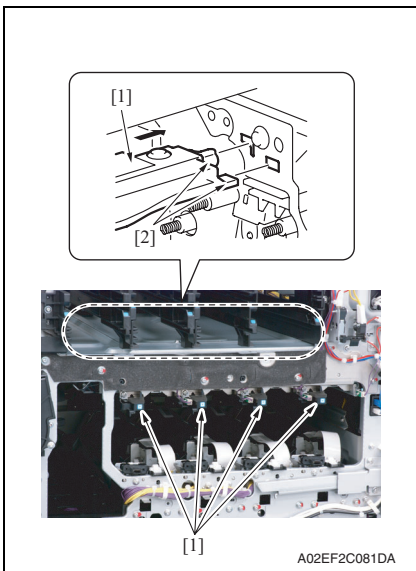

8. Install the imaging unit guide rails [1].

**NOTE**

- **Make sure that the two claws [2] at rear end of the rail are fit in the locating hole on the main unit.**

9. Reinstall the Image transfer belt unit.

10. Reinstall the front cover.

11. Make skew adjustment of the PH unit.

[See P.460](#)

**NOTE**

- When replacing the PH unit, make sure to conduct PH unit skew adjustment.

### 6.3.26 Manual bypass tray unit

1. Open the vertical transport door.
2. Remove the rear cover/3.  
[See P.92](#)
3. Remove the manual bypass tray front cover and the manual bypass tray rear cover.  
[See P.92](#)

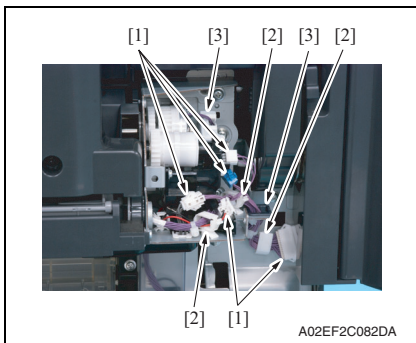

4. Disconnect five connectors [1], and remove the harness from the three wire saddles [2] and two edge covers [3].

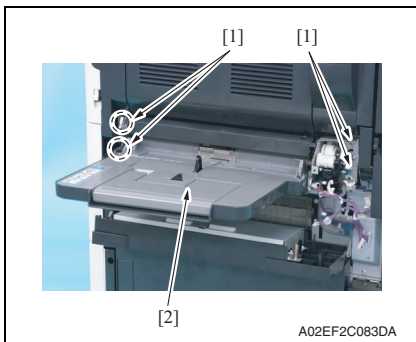

5. Remove four screws [1], and remove the manual bypass tray unit [2].

### 6.3.27 CCD unit

#### A. Removal procedure

1. Remove the original glass.  
See P.90

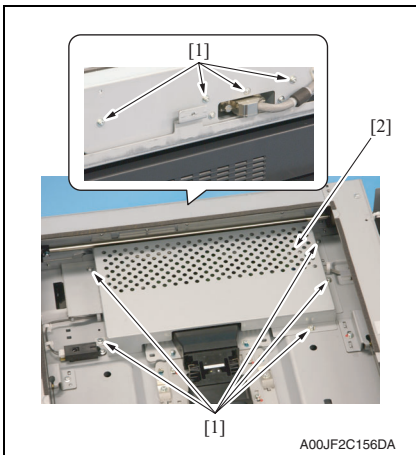

2. Remove nine screws [1], and remove the image processing board protective shield [2].

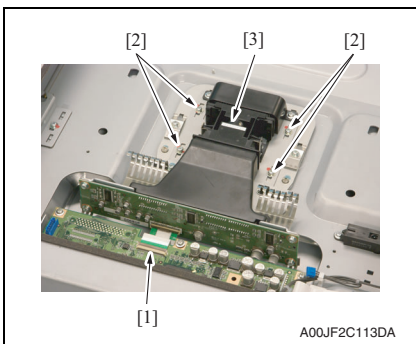

3. Remove the flat cable [1].
4. Remove four screws [2], and take out the CCD unit [3].

## B. Reinstall procedure

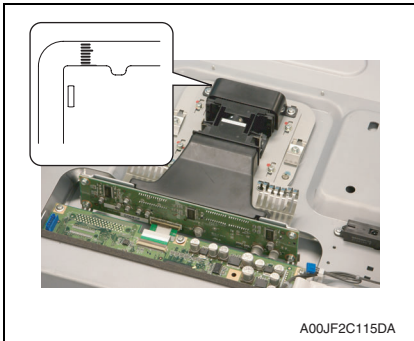

1. Set the CCD unit to the mounting position at the center of the scale, and fix it with four screws.

2. Reinstall the original glass.
3. Turn ON the main power switch and sub power switch.
4. Carry out the [Cross Direction Adjustment]. If the specifications are not met, loosen the CCD unit mounting screws and move the CCD unit in the sub scan direction as necessary.

[See P.354](#)

### NOTE

- **Hold the CCD unit by hand when moving it. NEVER use a screwdriver or similar tool to tap to move it, as a varied distance between the CCD sensor and lens results.**
- **When CCD unit is replaced, [Scan Calibration] and [Line Mag Setting] under [System 2] available in Service Mode should be OFF.**

### 6.3.28 Original glass moving unit

#### A. Removal procedure

1. Remove the IR left cover.  
[See P.89](#)
2. Remove the IR right cover.  
[See P.89](#)
3. Remove the IR upper front cover.  
[See P.89](#)
4. Remove the IR front cover.  
[See P.90](#)
5. Remove the original glass.  
[See P.90](#)
6. Remove the IR upper rear cover/1, the IR upper rear cover/2 and the IR upper rear cover/3.  
[See P.89](#)
7. Remove the original glass moving motor.  
[See P.106](#)
8. Remove the glass step sheet.  
[See P.109](#)

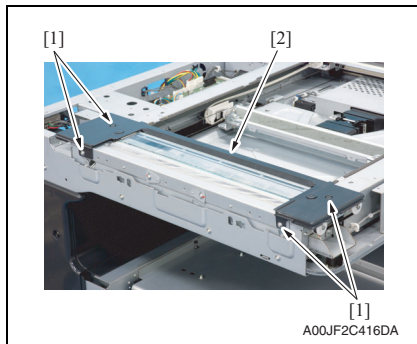

9. Remove four screws [1], and remove the original glass moving unit cover [2].

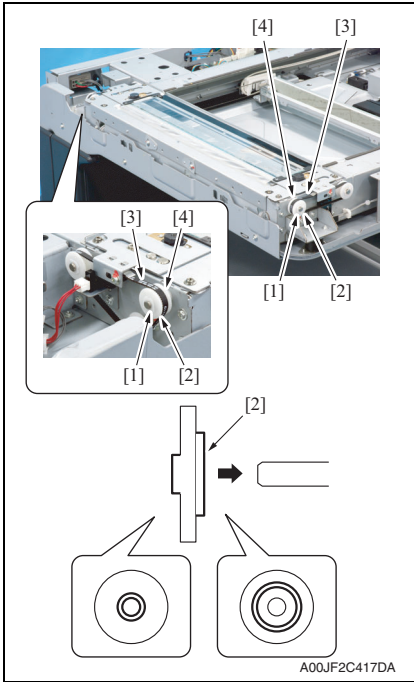

10. Remove the C-ring [1] and the collar [2] one each, and remove the belts [3] of both sides of the original glass mounting unit out of the gear [4].

**NOTE**

- Be sure the direction of the collar [2] to be as shown in the left illustration when mounting it.

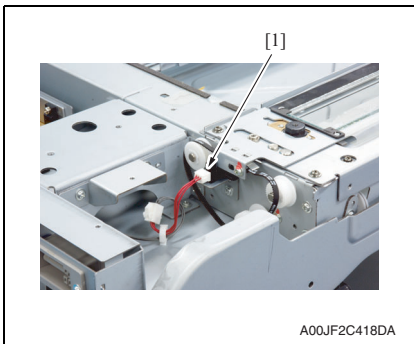

11. Disconnect the connector [1].



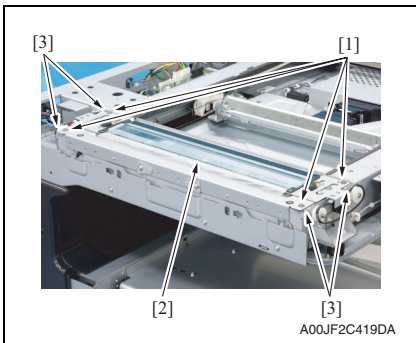

12. Remove four screws [1], and remove the original glass moving unit [2].

**NOTE**

- Use care not to lose the spacer [3] mounted on each screw.
- Write down the type and numbers of the spacer [3]. The same numbers of the spacer of the same type with what is written should be mounted when replacing the original glass moving unit.

**B. Reinstall procedure**

**NOTE**

- When replacing the original glass moving unit, clean the glass surface of the original glass moving unit.

Clean the inside of the glass well since it cannot be easily cleaned once it is mounted.

1. When mounting the new original glass moving unit, take out the original glass moving unit cover.

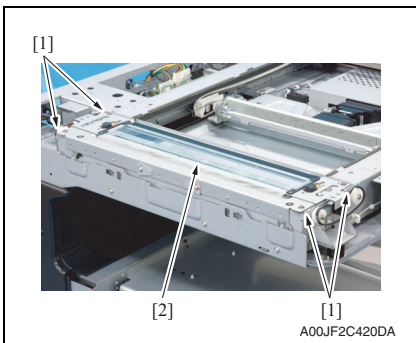

2. Set the spacers [1] and mount the original glass moving unit [2] to the machine.

**NOTE**

- Make sure to set the spacers [1] which are exact same type and number as before removing the original glass moving unit.

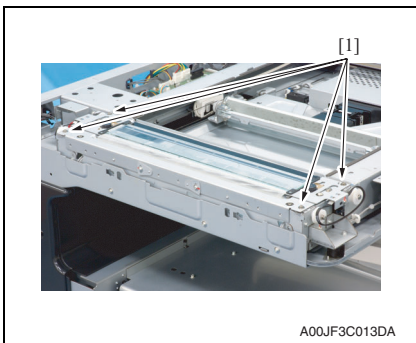

3. Tighten four screws [1] loosely and adjust the height of the original glass moving unit.

[See P.454](#)

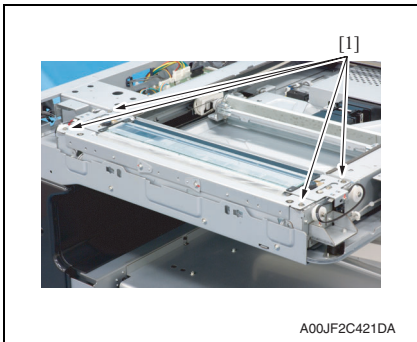

A00JF2C421DA

4. Tighten four screws [1] fully.

- 5. Follow the removing procedures in the opposite steps.
- 6. Perform the following setting.  
[Service Mode] → [ADF] → [Read Pos Adj]  
[See P.32 of the DF-611 service manual.](#)

### 6.3.29 Glass step sheet

#### A. Removal procedure

- 1. Remove the IR left cover.  
[See P.89](#)

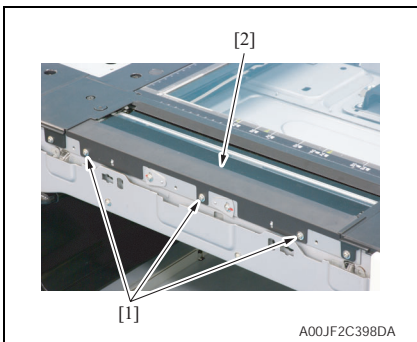

A00JF2C398DA

- 2. Remove three screws [1], and remove the glass step sheet [2].

### B. Reinstall procedure

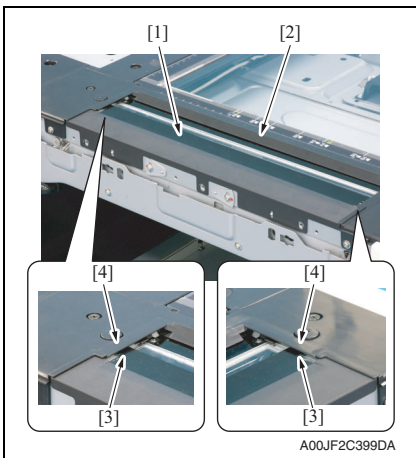

1. Mount the glass step sheet [1] to the original glass moving unit [2].

#### NOTE

- Set the sheet [3] under the cover of the original glass moving unit [4].
- Use care not to bend the edge of the glass step sheet.

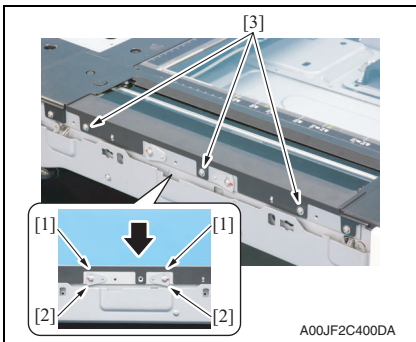

2. Set the points [1] of the glass step sheet to the edge of the scale plate [2] on the original glass moving unit, and mount it with three screws [3].

3. Perform the following setting.  
 [Service Mode] → [ADF] → [Read Pos Adj]  
[See P.32 of the DF-611 service manual.](#)

### 6.3.30 Scanner assy

#### A. Removal procedure

1. Remove the original glass.  
See P.90

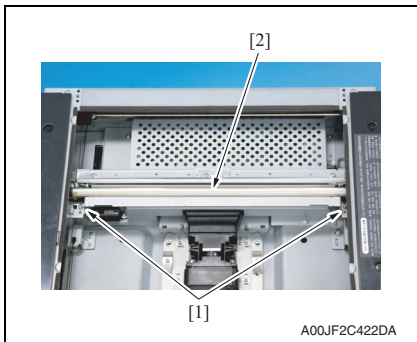

2. Remove two screws [1], and remove the scanner assy [2].

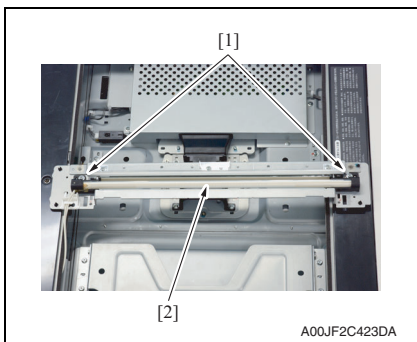

3. Remove two screws [1], and remove the exposure lamp [2] from the scanner assy.

#### B. Reinstall procedure

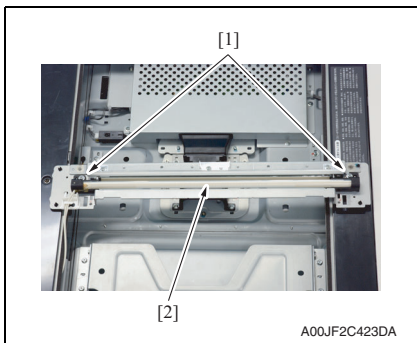

1. Fix the exposure lamp [2] to the scanner assy with the two screws [1].

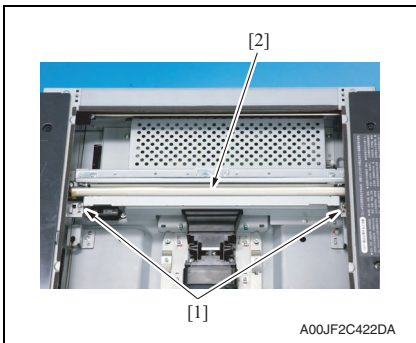

2. Tighten the scanner assy [2] with the two screws [1] temporarily.

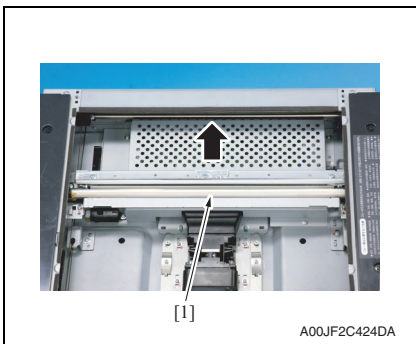

3. Move the scanner assy [1] and the mirror unit to the end of the right.

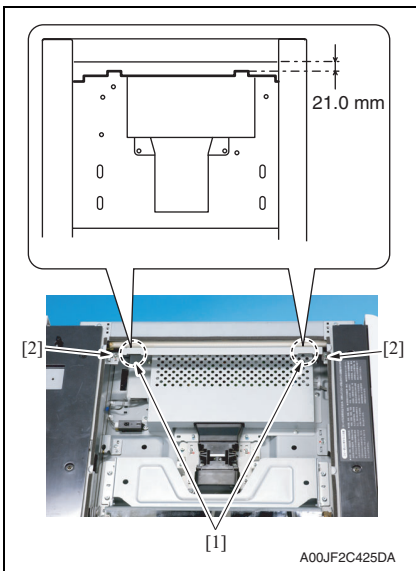

4. Slide the mirror unit until it hits the end of the IR right frame.
5. Provide the length of 21.0 mm between the end of the left indentation [1] on the scanner assy upper surface and the end of the IR right frame upper surface. When the length is ensured, tighten the two screws [2].

6. Perform the following setting.  
 [Service Mode] → [ADF] → [Read Pos Adj]  
 See P.32 of the DF-611 service manual.

### 6.3.31 Hard disk drive (HDD)

1. Remove the hard disk drive unit.  
[See the steps 1 to 8 of printer control board removing procedure.](#)  
[See P.136](#)

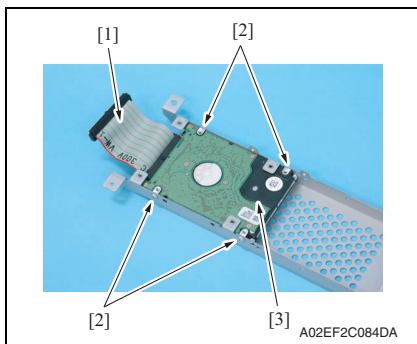

2. Disconnect the connector [1].
3. Remove four screws [2], and remove the hard disk drive [3].

#### NOTE

- When the hard disk is replaced, select [State Confirmation] → [Memory/HDD Adj.] → [HDD Format] in Service Mode for logical format.

### 6.3.32 Main drive unit

1. Remove the transfer belt unit.  
[See P.43](#)
2. Remove the high voltage unit.  
[See P.142](#)
3. Remove the Color PC motor.  
[See P.154](#)
4. Remove the transport motor.  
[See P.154](#)

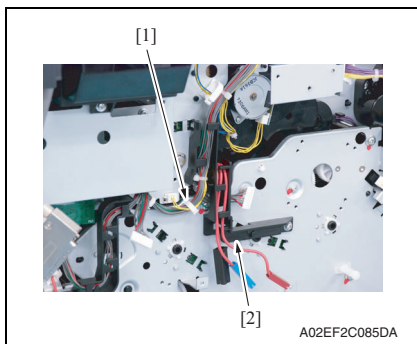

5. Remove the harness from the wire saddle [1] and the harness cover [2].

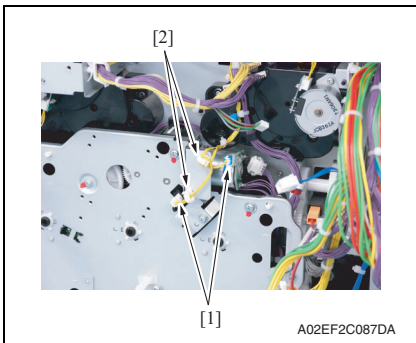

- 6. Disconnect two connectors [1], and remove the harness from two wire saddles [2].

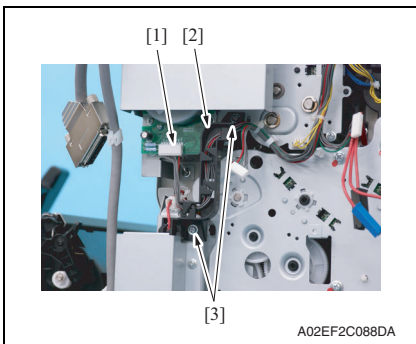

- 7. Disconnect the connector [1], and remove the harness from the harness guide [2].
- 8. Remove two screws [3], and remove the harness guide [2].

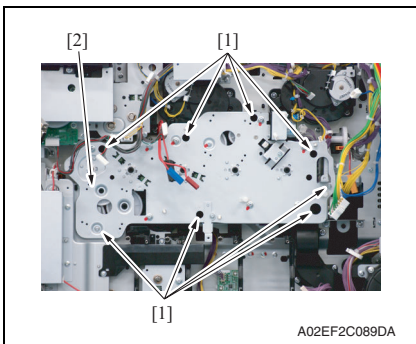

- 9. Remove eight screws [1], and slide out the main drive unit [2].

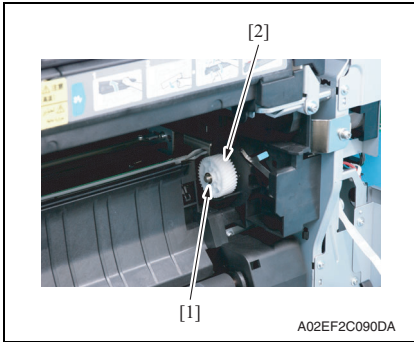

10. Remove the E-ring [1], and remove the gear [2].

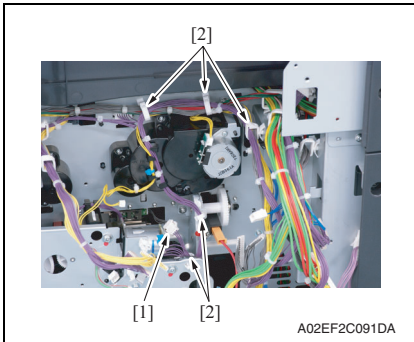

11. Disconnect the connector [1], and remove the harness from five wire saddles [2].  
 12. Remove the main drive unit.

**6.3.33 Transport drive unit**

1. Remove the main drive unit.  
[See P.113](#)
2. Remove the lower rear cover/1 and the lower rear cover/2.  
[See P.93](#)

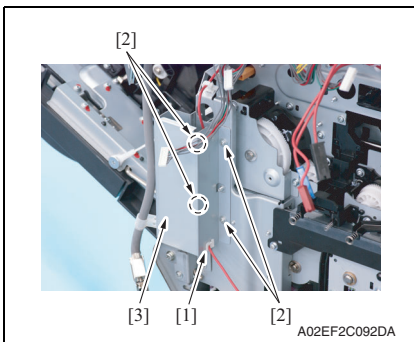

3. Remove the harness from the edge cover [1].
4. Remove four screws [2], and remove the metal plate [3].



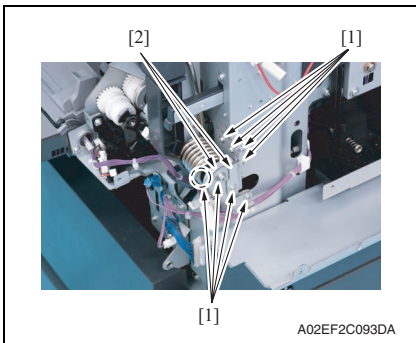

- 5. Close the right door.
- 6. Remove eight screws [1], and remove two reinforcement plates [2] of the right door.

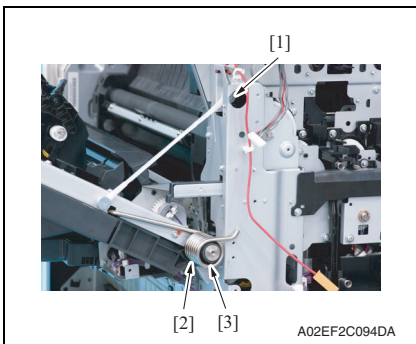

- 7. Remove the shoulder screw [1], the spring [2] and the collar [3].

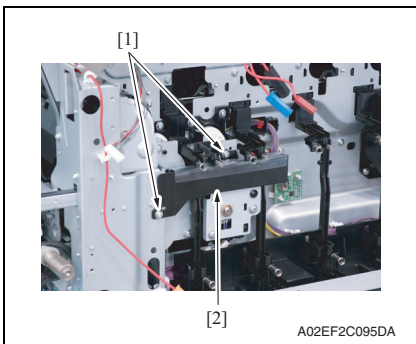

- 8. Remove two screws [1], and remove the rear handle cover [2].

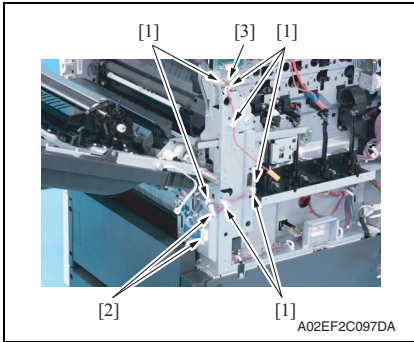

- 9. Remove the harness from seven wire saddles [1].
- 10. Disconnect two connectors [2], and remove the harness from the edge cover [3].

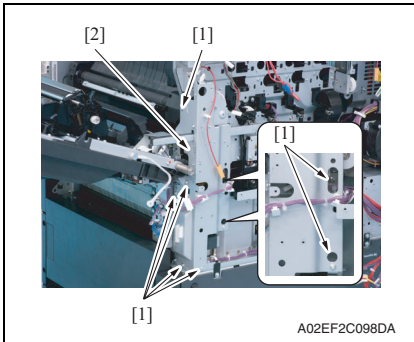

- 11. Remove seven screws [1], and remove the rear handle assy [2].

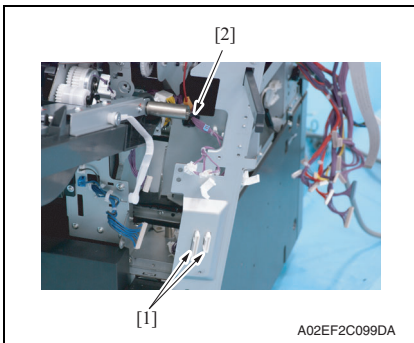

- 12. Disconnect two connectors [1], and remove the harness from the edge cover [2].

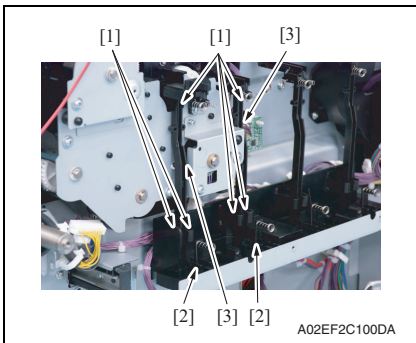

- 13. Remove each six tabs [1] and two hooks [3].
- 14. Remove two wire guides [2].

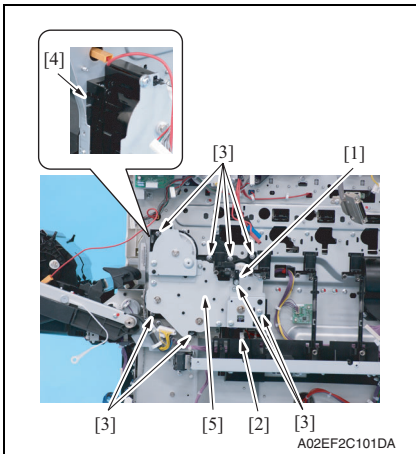

- 15. Remove the wire guide [1] and eight screws [3], and disconnect the connector [2].
- 16. Unhook the tab [4], and remove the transport drive unit [5].

### 6.3.34 Fusing drive unit

1. Remove the transfer belt unit.  
See P.43
2. Remove the fusing unit.  
See P.46
3. Remove the fusing motor.  
See P.155

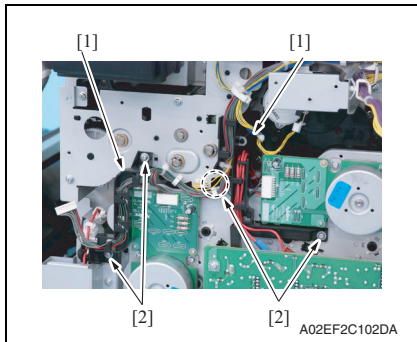

4. Remove the harness from two harness guides [1].
5. Remove four screws [2], and remove the harness guide [1].

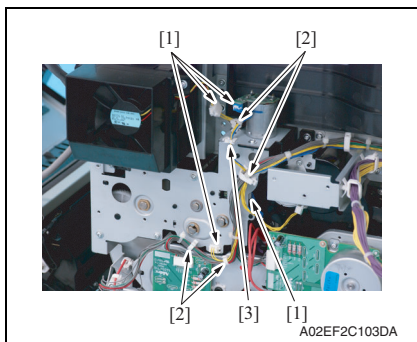

6. Disconnect four connectors [1], and remove the harness from four wire saddles [2].
7. Remove the harness from the edge cover [3].

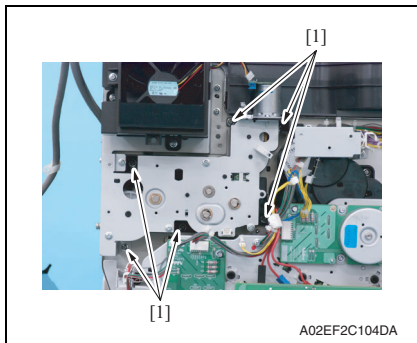

8. Remove six screws [1] of the fusing drive unit.

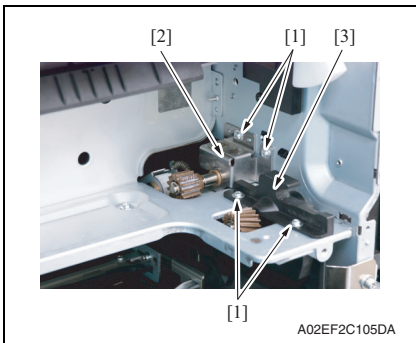

- 9. Remove four screws [1], and remove the fusing rear guide [2] and the shaft cover [3].

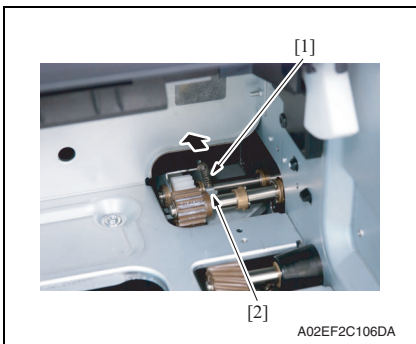

- 10. Remove the spring [1] from the protrusion [2].

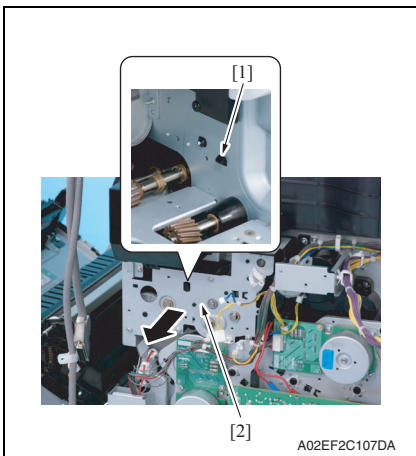

- 11. Unhook the tab [1]. Pull the fusing drive unit [2] to the front and remove it.

### 6.3.35 Hopper drive unit (C/K, Y/M)

#### A. Hopper drive unit (C/K)

1. Remove the main drive unit.

See P.113

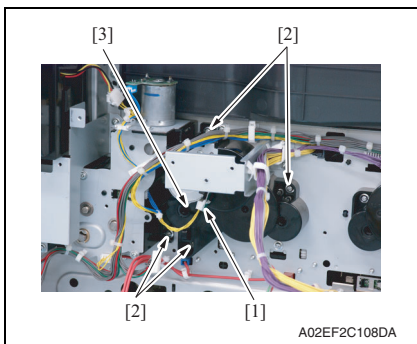

2. Disconnect the connector [1].
3. Remove four screws [2], and remove the hopper drive unit (C/K) [3].

#### B. Hopper drive unit (Y/M)

1. Remove the main drive unit.

See P.113

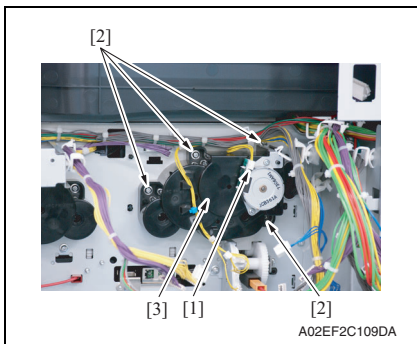

2. Disconnect the connector [1].
3. Remove four screws [2], and remove the hopper drive unit (Y/M) [3].

### 6.3.36 Right door assy

1. Remove the lower rear cover/1 and the lower rear cover/2.  
[See P.93](#)
2. Remove the manual bypass tray unit.  
[See P.103](#)
3. Remove the high voltage unit.  
[See P.142](#)
4. Slide out the tray 1.
5. Remove the right front cover/2.  
[See P.85](#)

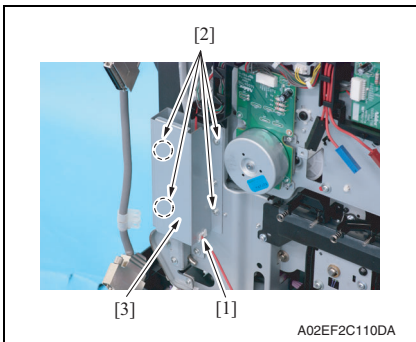

6. Remove the harness from the edge cover [1].
7. Remove four screws [2], and remove the metal plate [3].

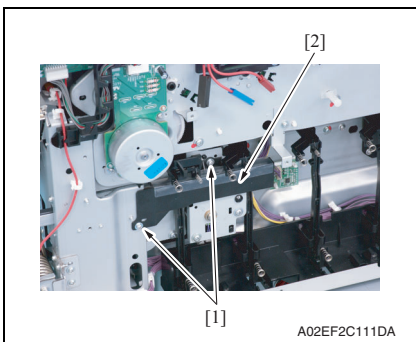

8. Remove two screws [1], and remove the rear handle cover [2].

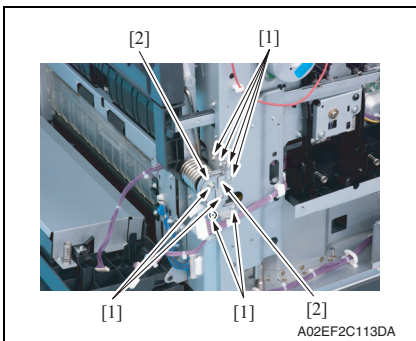

9. Remove eight screws [1], and remove two reinforcement plates [2] of the right door.

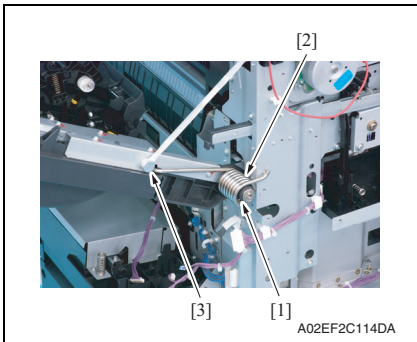

10. Open the right door, and remove the collar [1], the spring [2] and the shoulder screw [3].

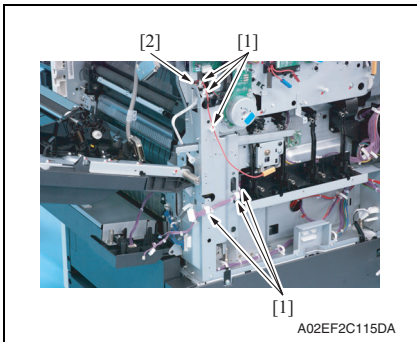

11. Remove the harness from six wire saddles [1] and the edge cover [2].

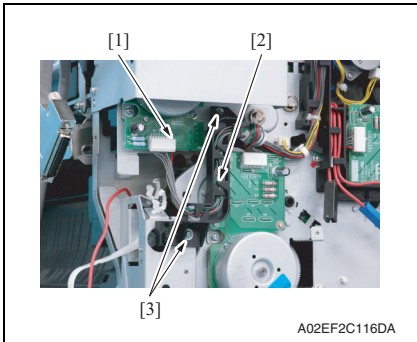

12. Disconnect the connector [1], and remove the harness from the harness guide [2].

13. Remove two screws [3], and remove the harness guide [2].



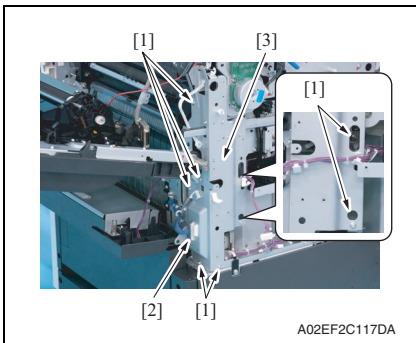

14. Disconnect the connector [2], remove seven screws [1], and remove the rear handle assy [3].

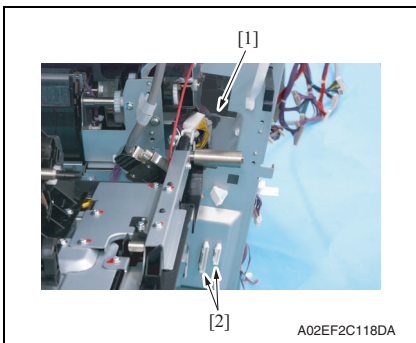

15. Disconnect two connectors [2], and remove the harness from the edge cover [1].

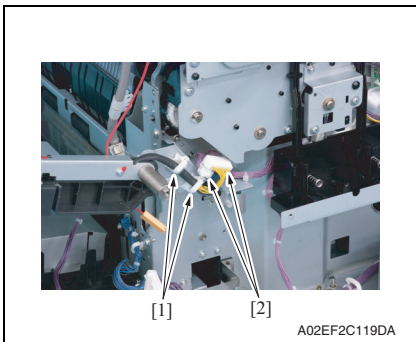

16. Remove two wire saddles [1] and two connectors [2].

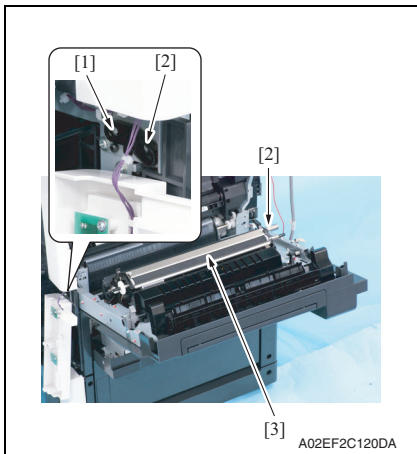

- 17. Remove the screw [1], and remove two shafts [2].
- 18. Remove the right door Assy [3].

### 6.3.37 IR Assy

- 1. Remove the IR left cover.  
[See P.89](#)
- 2. Remove the IR right cover.  
[See P.89](#)
- 3. Remove the IR upper front cover.  
[See P.89](#)
- 4. Remove the IR front cover.  
[See P.90](#)
- 5. Remove the IR rear cover.  
[See P.89](#)
- 6. Remove the IR upper rear cover/1, the IR upper rear cover/2 and the IR upper rear cover/3.  
[See P.89](#)
- 7. Remove the upper rear cover.  
[See P.92](#)

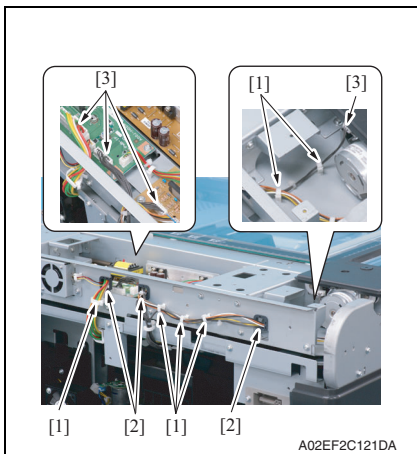

- 8. Disconnect four connectors [3], and remove the harness from six wire saddles [1] and three edge covers [2].

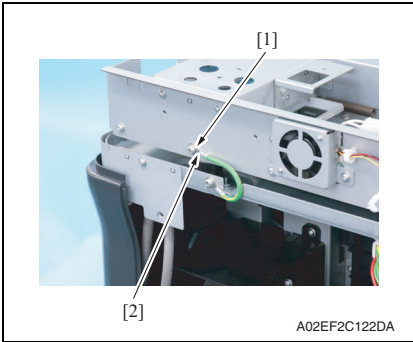

- 9. Remove the screw [1], and remove the ground terminal [2].

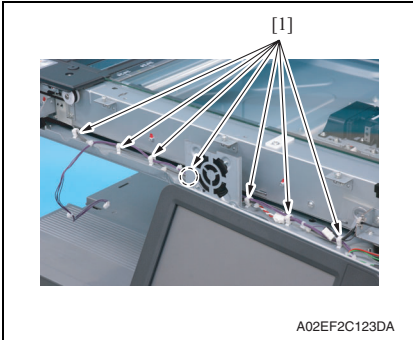

- 10. Remove the harness from seven wire saddles [1].

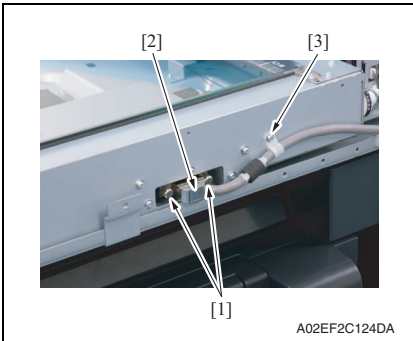

- 11. Loosen two screws [1] and remove the connector [2].
- 12. Remove the screw [3] that fixes the IR cable.

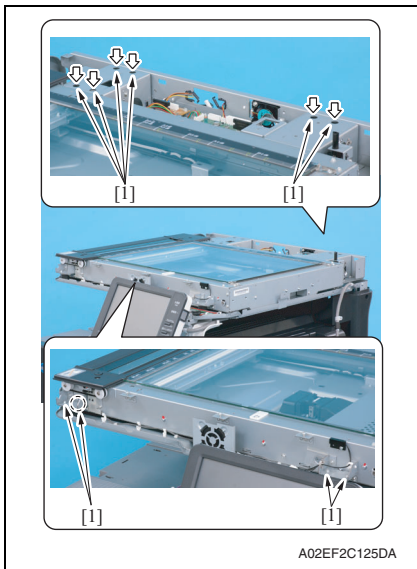

13. Remove ten screws [1], and remove IR Assy.

**NOTE**

- The two right rear screws are hidden under the seals. Peel off the stickers first and remove the screws.

**6.3.38 Scanner relay board (REYB/SCAN)**

1. Remove the IR upper rear cover/1 and the IR upper rear cover/2.  
[See P.89](#)

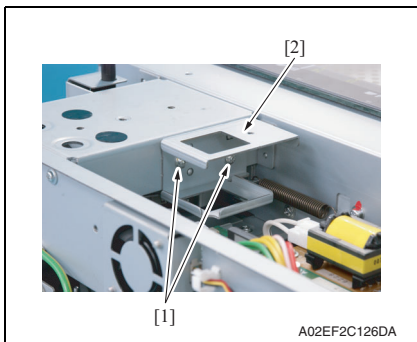

2. Remove two screws [1], and remove the bracket [2].

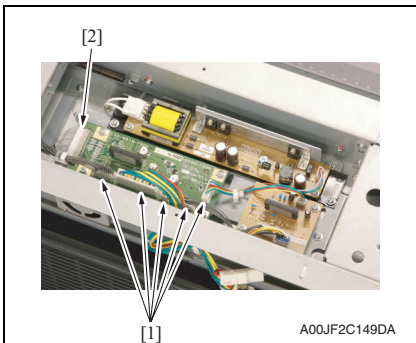

3. Disconnect five connectors [1] and the flat cable [2].

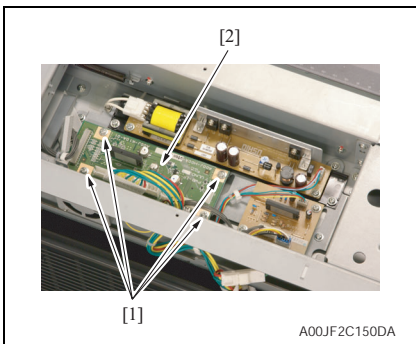

4. Remove four screws [1], and remove the scanner relay board [2].

### 6.3.39 Original glass position control board (OGPCB)

1. Remove the IR upper rear cover/1 and the IR upper rear cover/2.  
See P.89

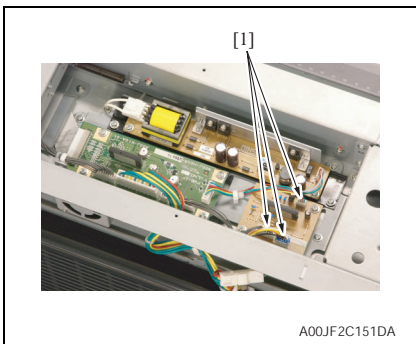

2. Disconnect three connectors [1].

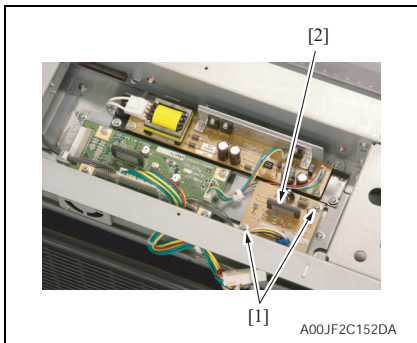

- 3. Remove two screws [1], and remove the original glass position control board [2].

### 6.3.40 Inverter board (INVB)

- 1. Remove the IR upper rear cover/1 and the IR upper rear cover/2.  
[See P.89](#)

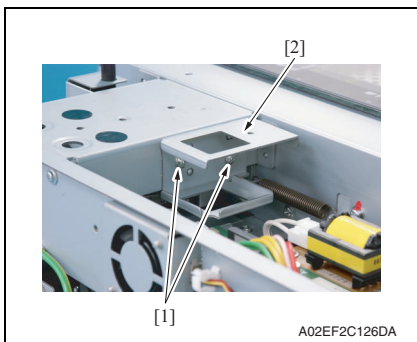

- 2. Remove two screws [1], and remove the bracket [2].

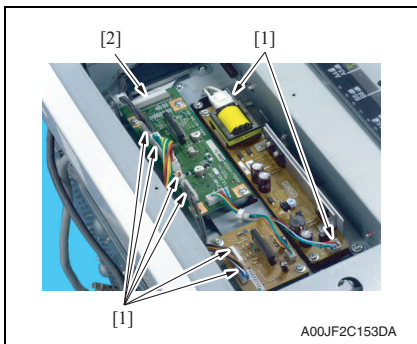

- 3. Disconnect eight connectors [1] and the flat cable [2].

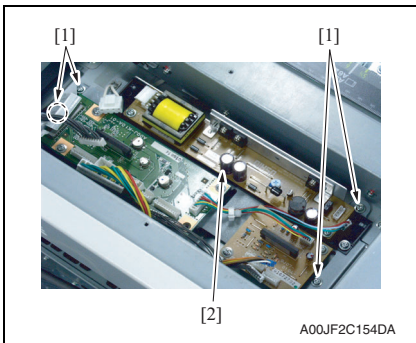

4. Remove four screws [1], and the inverter board assy [2].

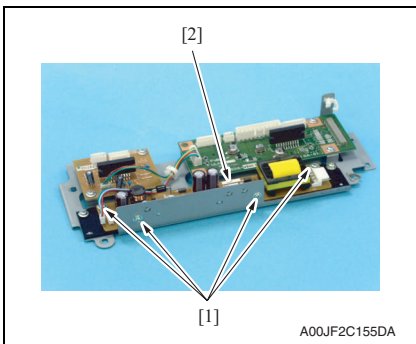

5. Remove four screws [1], and remove the inverter board [2].

### 6.3.41 Image processing board (IPB)

1. Remove the original glass.  
See P.90

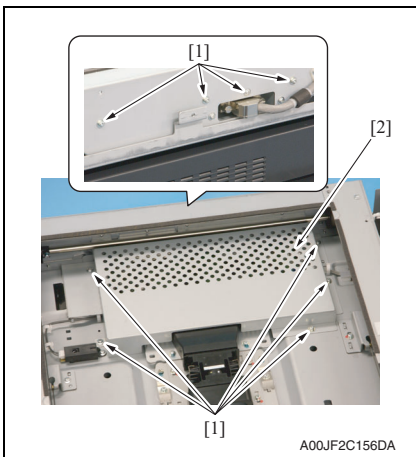

2. Remove nine screws [1], and remove the image processing board protective shield [2].

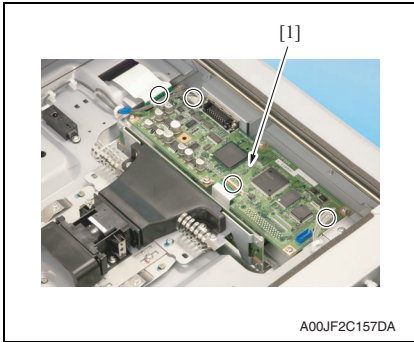

A00JF2C157DA

3. Remove all the connectors and flat cables on the image processing board [1].

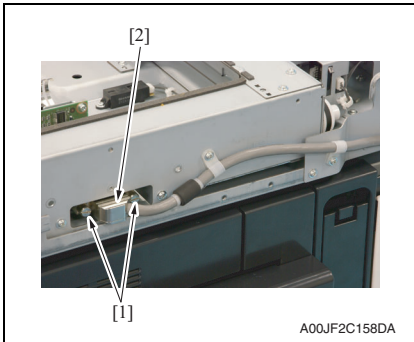

A00JF2C158DA

4. Loosen two screws [1], disconnect the IR cable connector [2].

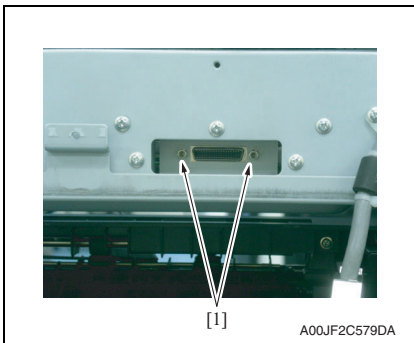

A00JF2C579DA

5. Remove the two bolts [1].



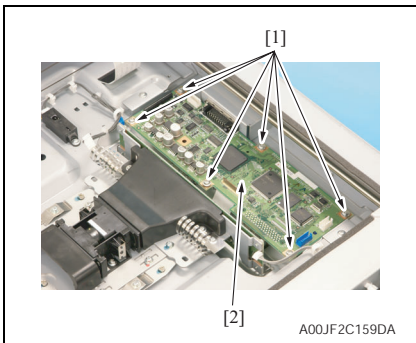

- Remove six screws [1], and remove the image processing board [2].

**NOTE**

- When the image processing board is replaced, make sure to update the firmware.

**6.3.42 PH relay board (REYB/PH)**

- Remove the front cover.  
[See P.96](#)
- Remove the transfer belt unit.  
[See P.43](#)

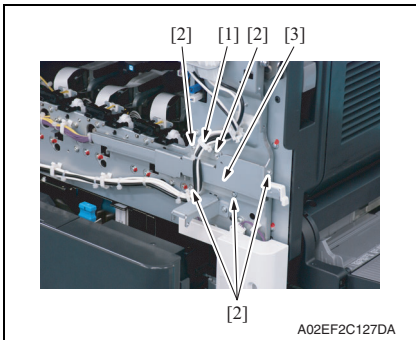

- Remove the harness from the wire saddle [1].
- Remove five screws [2], and remove the front handle assy [3].

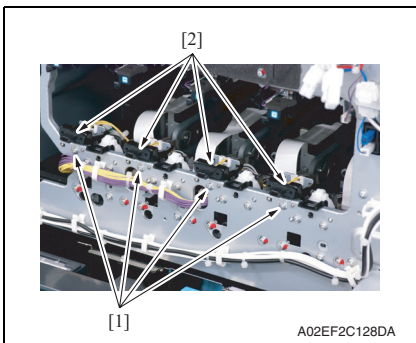

- Remove the screw [1] each, and remove the imaging unit contact assy [2] of each color.

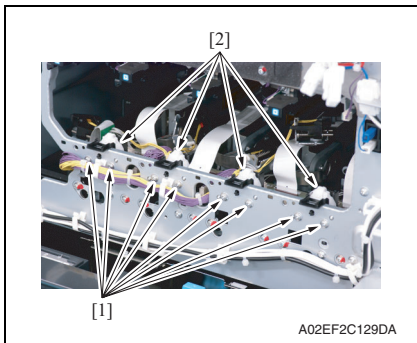

6. Remove two screws [1] each, and remove the imaging unit roll assy [2] of each color.

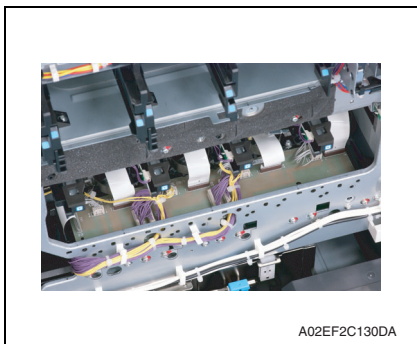

7. Remove all the connectors and the flat cables on the PH relay board.

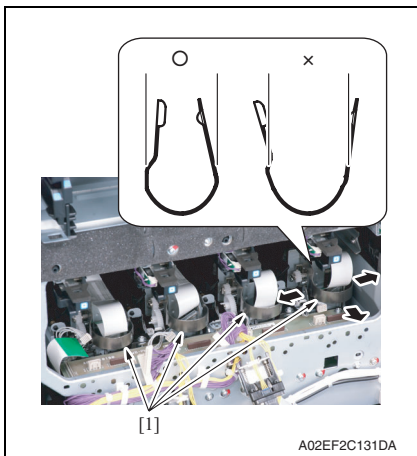

8. Remove the stopper [1] of the PH unit.

**NOTE**

- When removing the stopper, use care so that both ends of the stopper will not open but stay parallel as shown on the left. Keep using the stopper after once stretched out may cause uneven pitch or other image troubles.

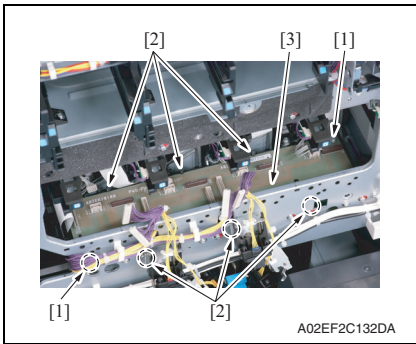

- Remove two screws [1] and six tabs [2], and remove the PH relay board [3].

### 6.3.43 DC power supply (DCPU)

 <b>CAUTION</b>
<ul style="list-style-type: none"> <li>Remove the DC power supply after six minutes or more have passed since the power plug was disconnected.</li> </ul>

- Remove the left cover.  
[See P.86](#)
- Remove the rear left cover/1.  
[See P.87](#)

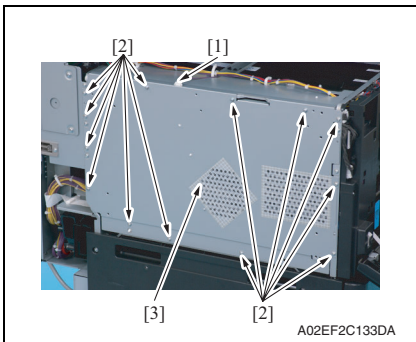

- Disconnect the connector [1].
- Remove thirteen screws [2], and remove the DC power supply protective shield [3].

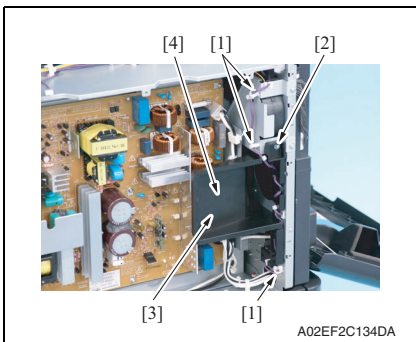

- Remove the harness from three wire saddles [1].
- Remove the harness from the cover [2].
- Remove the screw [3], and remove the cover [4].

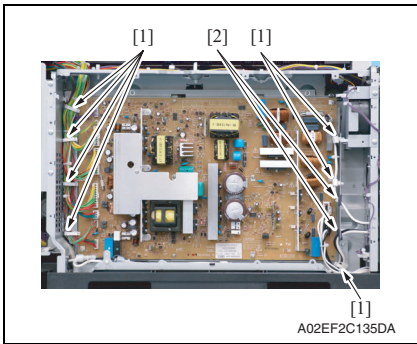

- 8. Remove the harness from seven wire saddles [1] and two edge covers [2].

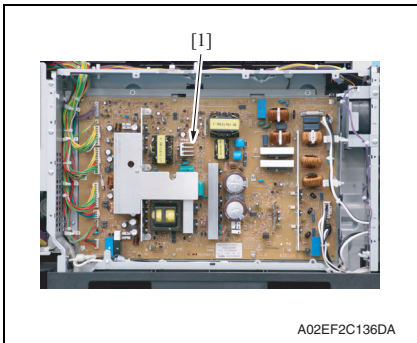

- 9. Remove all the connectors on the DC power supply [1].

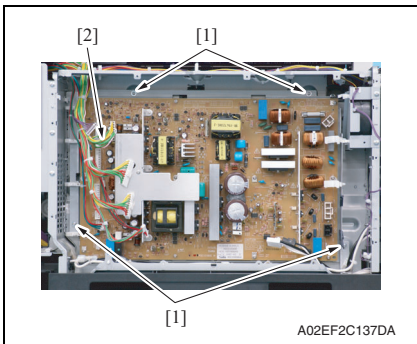

- 10. Remove four screws [1], and remove the DC power supply [2].

### 6.3.44 Printer control board (PRCB)

1. Open the front door.
2. Remove the rear left cover/1 and the rear left cover/2.  
[See P.87](#)
3. Remove the upper rear cover, the rear cover/1 and the rear cover/2.  
[See P.92](#)

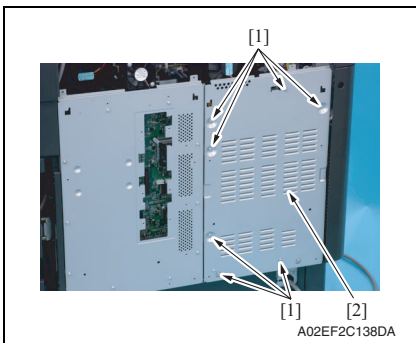

4. Remove seven screws [1], and remove the protective shield/2 [2].

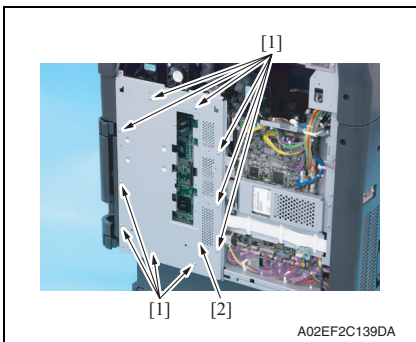

5. Remove ten screws [1], and remove the protective shield/1 [2].

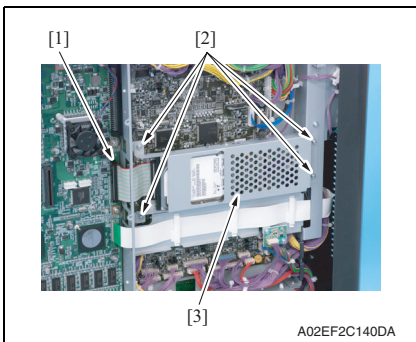

6. Disconnect the connector [1], remove four screws [2], and remove the hard disk drive unit [3].

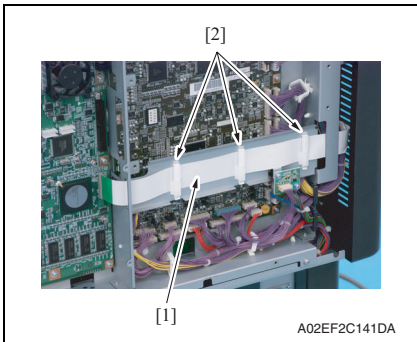

- 7. Disconnect the flat cable [1].
- 8. Remove the flat cable [1] from three cable holders [2] and get the flat cable out of the way.

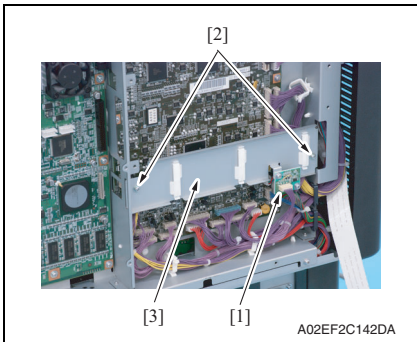

- 9. Disconnect the connector [1], remove two screws [2], and remove the metal plate [3].

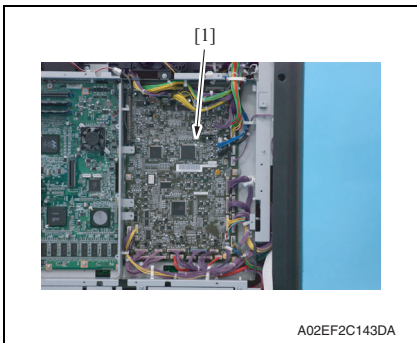

- 10. Remove all the connectors on the printer control board [1].

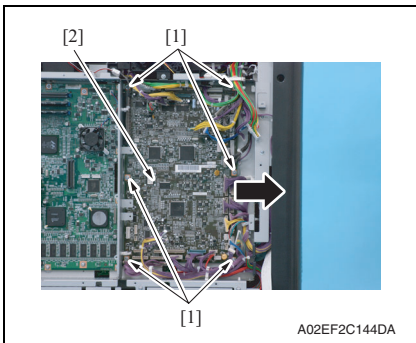

11. Remove six screws [1]. Slide the printer control board [2] in the direction of the arrow and remove it.

**NOTE**

- When the printer control board is to be replaced, rewriting the firmware to the latest one.

**6.3.45 MFP board (MFPB)**

1. Remove the protective shield/1 and the protective shield/2.  
[See the steps 1 to 5 of printer control board removing procedure.](#)  
[See P.136](#)
2. Remove the rear right cover/2 and the rear right cover/3.  
[See P.91](#)
3. Remove the NVRAM board.  
[See P.146](#)
4. Remove the JMP board.  
[See P.145](#)
5. Remove the SODIMM/1, SODIMM/2.  
[See P.145](#)

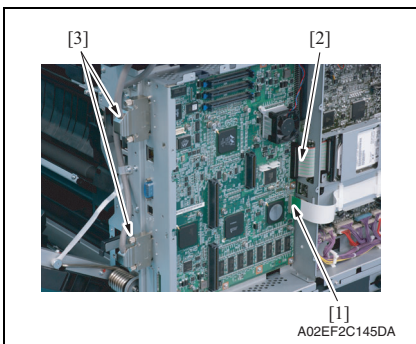

6. Disconnect the flat cable [1] and the connector [2], and remove two cables [3].

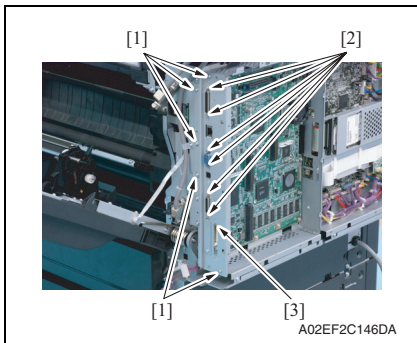

- Remove five screws [1] and six bolts [2], and remove the metal plate [3].

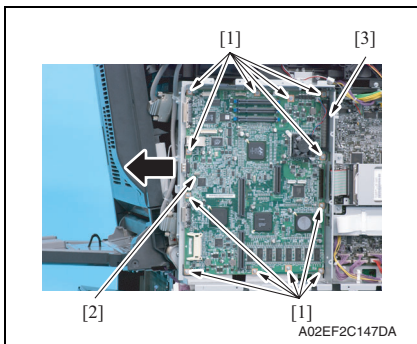

- Remove twelve screws [1] of the MFP board.
- Slide the MFP board [2] in the direction of the arrow, disconnect the connector [3], and remove the MFP board.

**NOTE**

- When the MFP board is to be replaced, rewriting the firmware to the latest one.

**6.3.46 PWB box**

- Remove the rear right cover/1 and the rear right cover/2.  
[See P.91](#)
- Remove the lower rear cover/1 and the lower rear cover/2.  
[See P.93](#)
- Remove the hard disk drive and the metal plate.  
[See the steps 1 to 6 of printer control board removing procedure.](#)  
[See P.136](#)

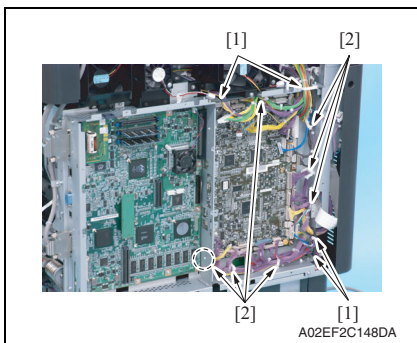

- Remove the harness from four edge covers [1] and seven wire saddles [2].



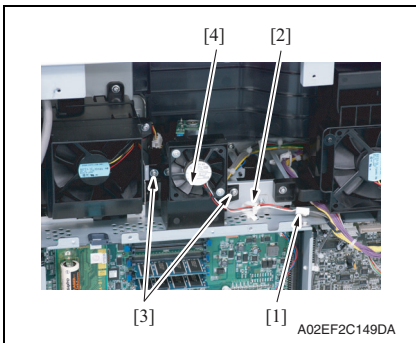

- 5. Disconnect the connector [1], and remove the harness from the wire saddle [2].
- 6. Remove two screws [3], and remove the MFP board cooling fan motor [4].

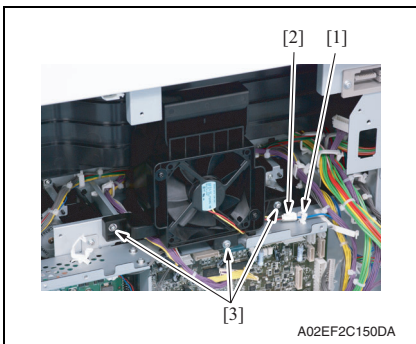

- 7. Remove the harness from the wire saddle [1], and disconnect the connector [2].
- 8. Remove three screws [3] of the cooling fan motor/2.

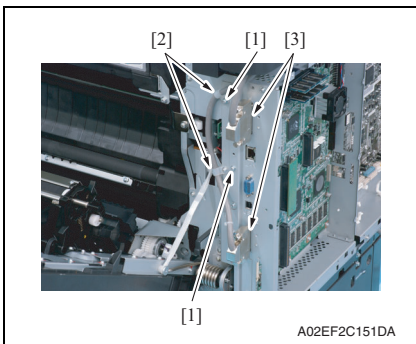

- 9. Remove two screws [1] and two cable clamps [2], and remove two cables [3].

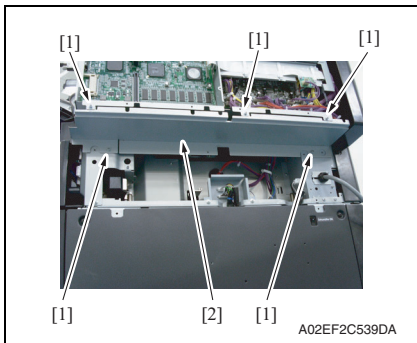

10. Remove five screws [1], and remove the metal plate [2].

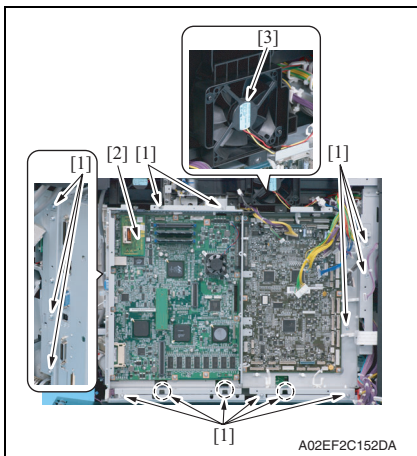

11. Remove fourteen screws [1]. While raising the PWB box [2] a little, slide it to the left. Then, remove the cooling fan motor/2 [3].

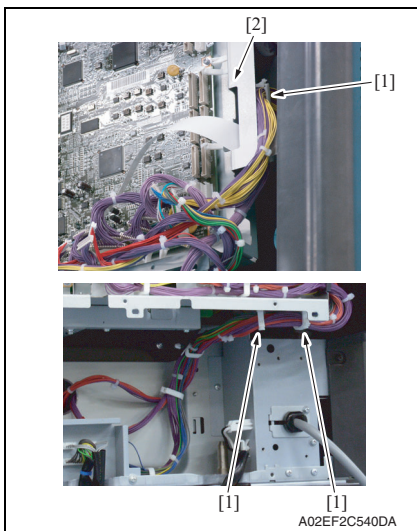

12. Remove the harness from three wire saddles [1], and remove the PWB box [2].



### 6.3.47 High voltage unit (HV)

1. Remove the PWB box  
See P.139

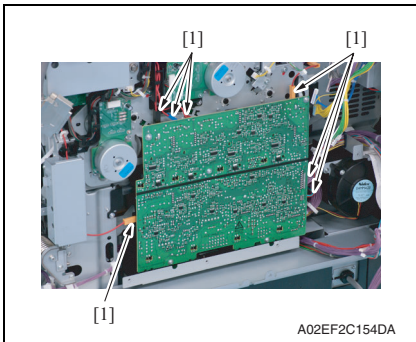

2. Disconnect seven connectors [1].

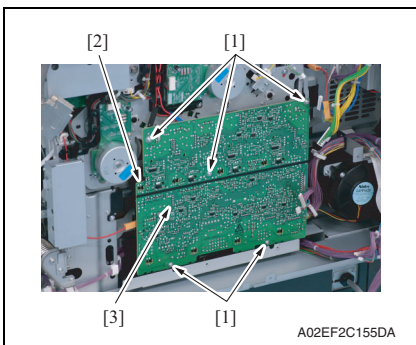

3. Remove five screws [1] and the tab [2], and remove the high voltage unit [3].

**NOTE**

- When reinstalling the high voltage unit, make sure that the terminal end surely contacts.

**6.3.48 Service EEPROM board (SV ERB)**

1. Remove the rear cover /1 and the rear cover /2  
See P.92
2. Remove the protective shield/1 and the protective shield/2.  
See the steps 1 to 5 of printer control board removing procedure.  
See P.136

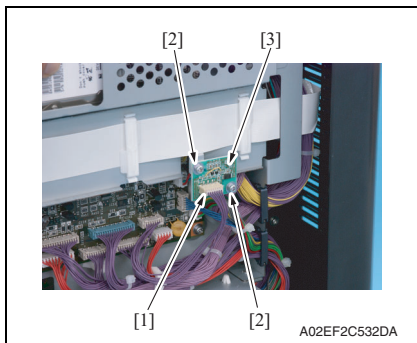

3. Remove two screws [2] and the connector [1], and take out the service EEPROM board [3].

**NOTE**

After replacing the service EEPROM board, all parts shown below are required to be replaced with new ones.

- Imaging unit Y/M/C/K
- Toner cartridge Y/M/C/K
- Image transfer belt unit
- Fusing unit

**NOTE**

• When Service EEPROM is replaced, data of all adjustment settings stored in EEPROM disappear and the adjustment settings are returned to the default ones. After replacing the service EEPROM board, take the following steps to make readjustments.

4. Open the front door and turn OFF and ON the main power switch and sub power switch.
5. Enter the Service mode. Make individual adjustments shown in the following table in the order listed, using the machine maintenance list and the adjustment lists that were output at the time of main body installation and maintenance.

**NOTE**

- At this time, a front door must be an open state.

Order	Items that require readjustment in the Service mode		Ref. page
1	Machine	Color Registration Adjustment	Cyan
2			Magenta
3			Yellow
4	Imaging Process Adjustment	TCR Level Setting	
5		Background Voltage Margin	
6		D Max Density	
7		Dev. Bias Choice	
8	System 1	Change Warm Up Time	



Order	Items that require readjustment in the Service mode		Ref. page	
9	Machine	Exhaust Fan Stop Delay	P.358	
10	System 2	Unit Change	Warning Display	P.396
11	System 1	IU Life Setting	P.392	

**NOTE**

- **After replacing the service EEPROM board, be sure to make the above listed adjustments before the first warm-up is made.**

6. Turn OFF the main power switch and sub power switch.
7. Close the front door and turn ON the main power switch and sub power switch.  
Check to see that warm-up and image stabilization operations are completed normally.
8. Enter the Service mode again. Make individual adjustments shown in the following table in the order listed, using the machine management list and the adjustment lists that were output at the time of main body installation and maintenance.

Order	Items that require readjustment in the Service mode		Ref. page		
1	Machine	LD adjustment	LD lightness balance adjust.	P.359	
2		Manual Bypass Tray Adjustment		P.360	
3		Printer Resist Loop		P.356	
4		Fusing Temperature		P.345	
5	Finisher	CB-FN adjustment	Fold&Staple Pos. Adjustment	P.431	
6			Finisher Check		
7			Punch Regist Loop Size		
8			Punch Horizontal Position		
9	Machine	Printer Area	Paper Feed Direction Adj.	P.351	
10		Fusing Transport Speed		P.346	
11		Printer Area	Centering	P.348	
12			Centering (Duplex 2nd Side)	P.350	
13			Leading Edge Adjustment	P.347	
14			Leading Edge Adj. (Duplex Side 2)	P.349	
15		Imaging Process Adjustment	Transfer Output Fine Adjustment	Secondary transfer adj.	P.365
16				Primary transfer adj.	P.364

### 6.3.49 SODIMM/1, SODIMM/2

1. Remove the protective shield/1 and the protective shield/2.  
[See the steps 1 to 5 of printer control board removing procedure.](#)  
[See P.136](#)

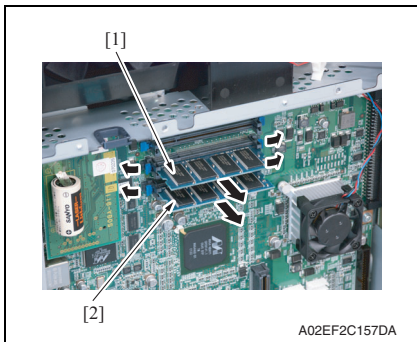

2. Remove the SODIMM/1 [1] and SODIMM/2 [2] on the MFP board.

### 6.3.50 JMP board (JMPB)

1. Remove the protective shield/1 and the protective shield/2.  
[See the steps 1 to 5 of printer control board removing procedure.](#)  
[See P.136](#)

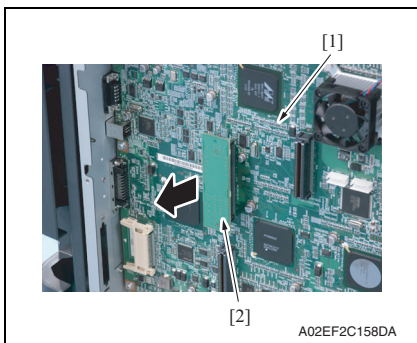

2. Remove the JMP board [2] on the MFP board [1].

### 6.3.51 NVRAM board (NRB)

1. Remove the protective shield/1 and the protective shield/2.  
[See the steps 1 to 5 of printer control board removing procedure.](#)  
[See P.136](#)

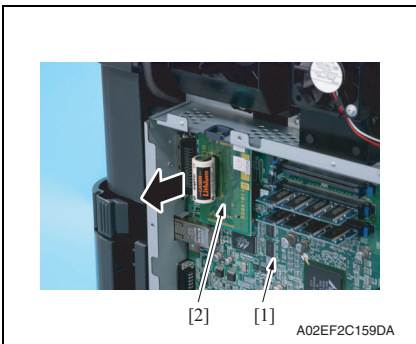

2. Remove the NVRAM board [2] on the MFP board [1].

### 6.3.52 Machine condition monitor board (MCMB)

1. Remove the IR left cover.  
[See P.89](#)
2. Remove the IR right cover.  
[See P.89](#)
3. Remove the IR upper front cover.  
[See P.89](#)
4. Remove the IR front cover.  
[See P.90](#)

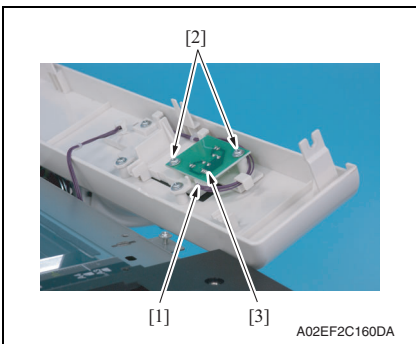

5. Disconnect the connector [1], remove two screws [2], and remove the machine condition monitor board [3].

### 6.3.53 Paper feed tray 1 paper FD size detect board (PSDTB/1)

1. Remove the tray 1.  
See P.95
2. Remove the tray 2.  
See P.95

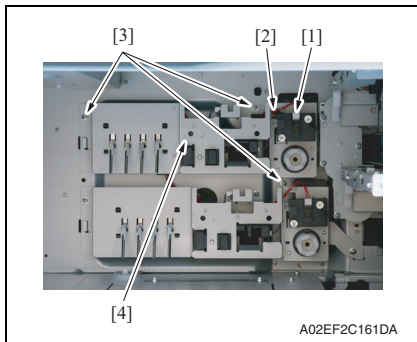

3. Disconnect the connector [1], and remove the harness from the edge cover [2].
4. Remove three screws [3], take out the paper feed tray 1 lift-up motor assy [4] and turn it around.

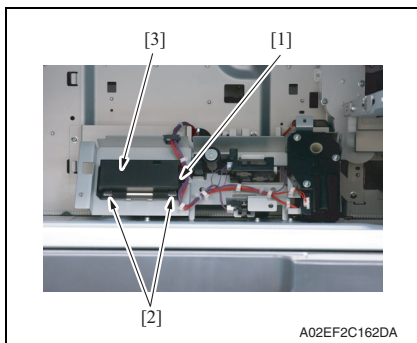

5. Disconnect the connector [1].
6. Unhook two tabs [2] and remove the paper feed tray 1 paper FD size detect board assy [3].

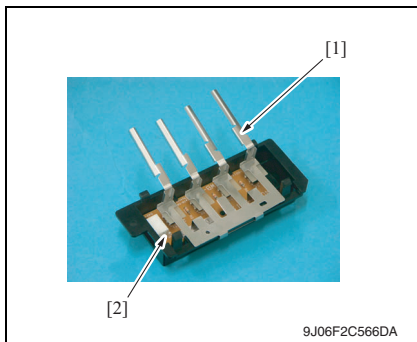

7. Remove the lever [1], and remove the paper feed tray 1 paper FD size detect board [2].



### 6.3.54 Paper feed tray 2 paper FD size detect board (PSDTB/2)

1. Remove the tray 1.  
[See P.95](#)
2. Remove the tray 2.  
[See P.95](#)

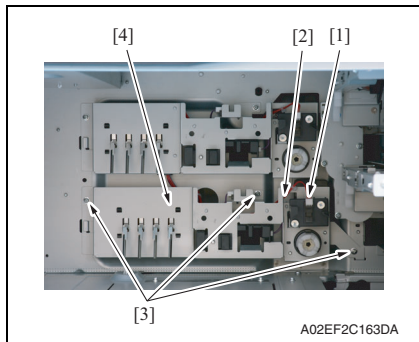

3. Disconnect the connector [1], and remove the harness from the edge cover [2].
4. Remove three screws [3], take out the paper feed tray 2 lift-up motor assy [4] and turn it around.

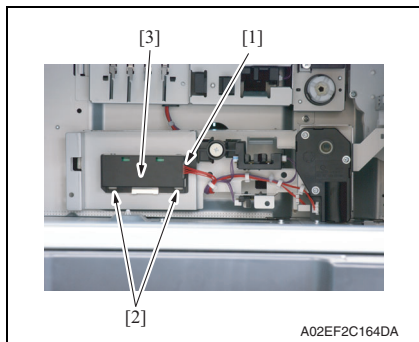

5. Disconnect the connector [1].
6. Unhook two tabs [2] and remove the paper feed tray 2 paper FD size detect board assy [3].

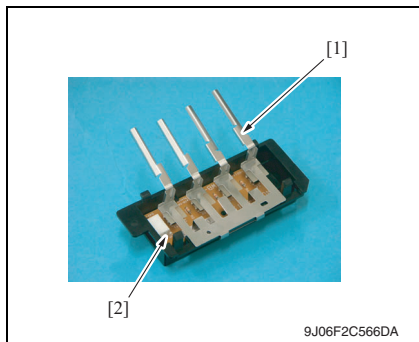

7. Remove the lever [1], and remove the paper feed tray 2 paper FD size detect board [2].

### 6.3.55 Scanner motor (M201)

#### A. Removal procedure

1. Remove the IR rear cover.

See P.89

2. Remove the IR upper rear cover/1 and the IR upper rear cover/2.

See P.89

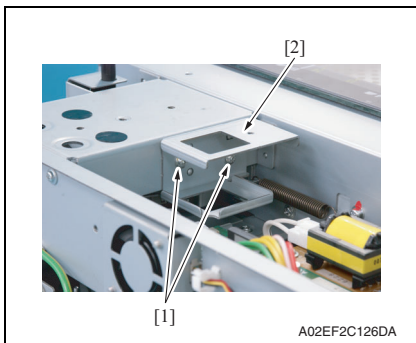

3. Remove two screws [1], and remove the bracket [2].

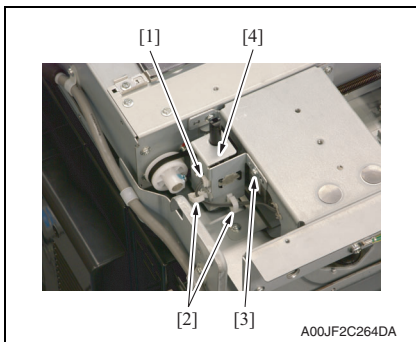

4. Remove the connector [1] and take out the harnesses from two wire saddles [2].
5. Remove the screw [3], and remove the 20 degree sensor assy [4].

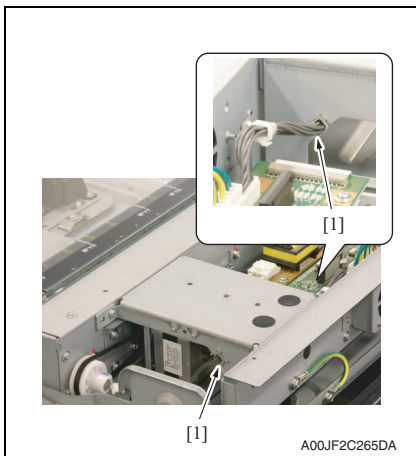

6. Remove the harness from two edge covers [1].

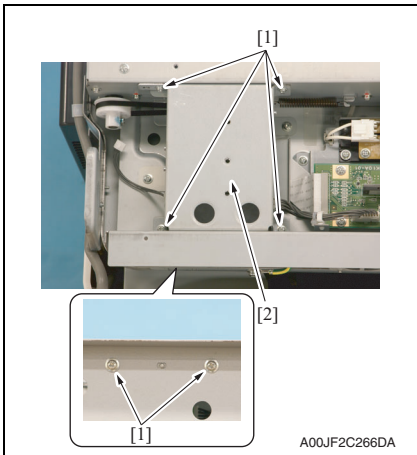

- 7. Remove six screws [1] and take out the ADF table [2].

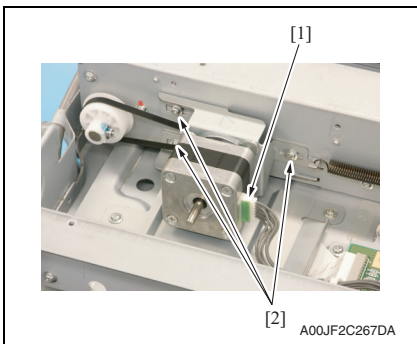

- 8. Disconnect the connector [1] and remove three screws [2].

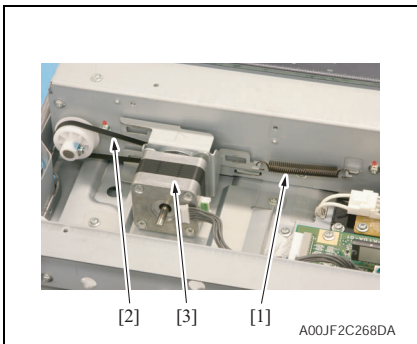

- 9. Remove the spring [1] and the belt [2], and take out the scanner motor assy [3].

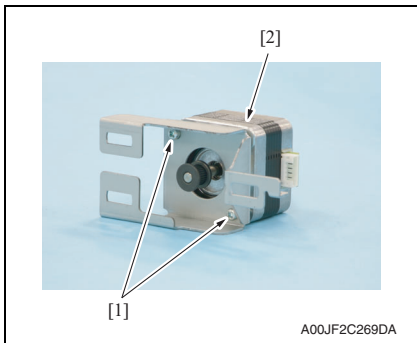

10. Remove two screws [1], and remove the scanner motor [2].

### B. Reinstall procedure

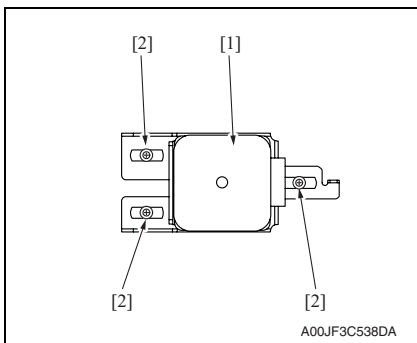

1. Temporarily secure the scanner motor assy [1] with three screws [2].

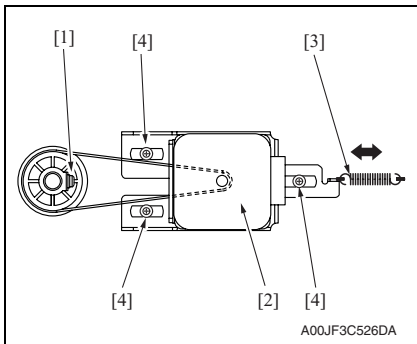

2. With the scanner drive gear set screw [1] located on the right-hand side as shown on the left, slide the scanner motor assy [2] to the left and check that it is returned to the original position by the tension of the spring [3]. Perform this step three times.
3. Turn the pulley and make sure that the belt does not ride up on the pulley teeth.
4. Tighten the three screws [4] to fix the scanner motor assy into position.

### 6.3.56 Original glass moving motor (M202)

1. Remove the IR rear cover.  
See P.89
2. Remove the IR upper rear cover/1, the IR upper rear cover/2 and the IR upper rear cover/3.  
See P.89

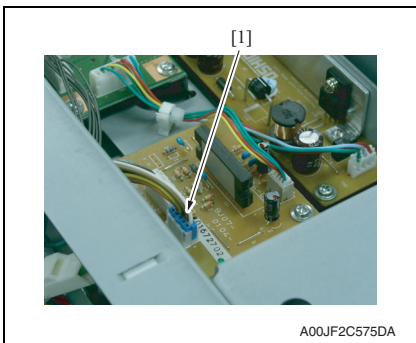

3. Disconnect the connector [1].

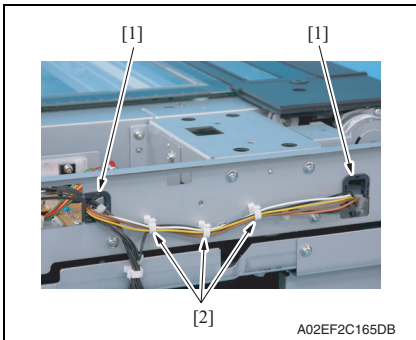

4. Remove the harness from two edge covers [1] and three wire saddles [2].

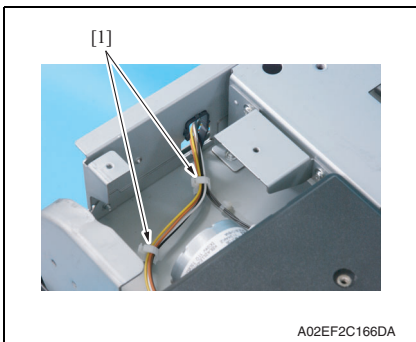

5. Remove the harness from two wire saddles [1].

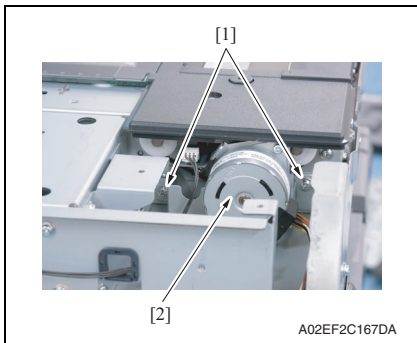

6. Remove two screws [1], and remove the original glass moving motor assy [2].

**⚠ 6.3.57 Duplex transport motor (M7)**

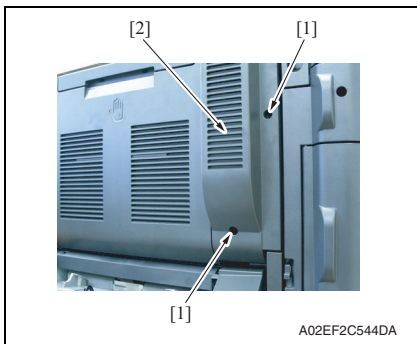

1. Remove two screws [1], and remove the duplex cover [2].

2. Open the right door.

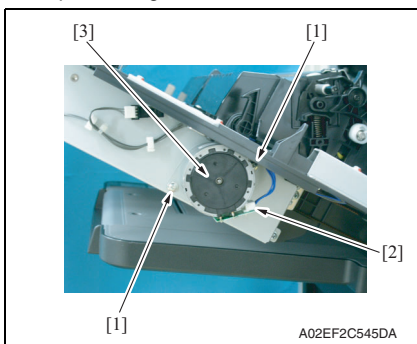

3. Remove two screws [1], disconnect the connector [2], and remove the duplex transport motor [3].

### 6.3.58 Transport motor (M1)

1. Remove the PWB box.  
[See P.139](#)

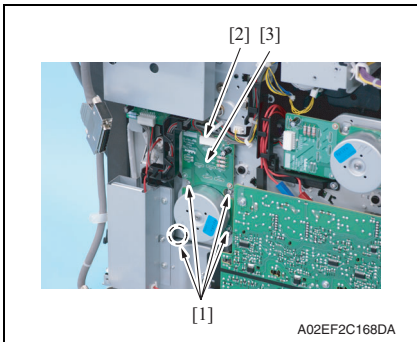

2. Remove four screws [1], disconnect the connector [2], and remove the transport motor [3].

### 6.3.59 Color PC motor (M2)

1. Remove the PWB box.  
[See P.139](#)

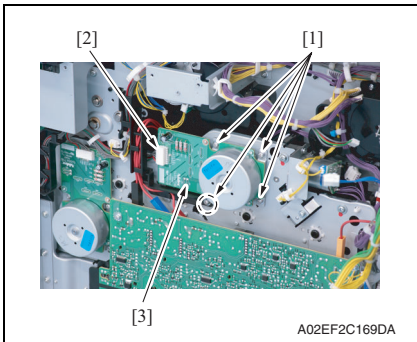

2. Remove four screws [1], disconnect the connector [2], and remove the color PC motor [3].

### 6.3.60 Fusing motor (M5)

1. Remove the PWB box.  
[See P.139](#)

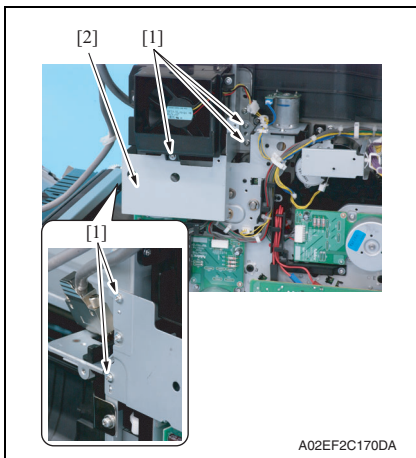

2. Remove five screws [1], and remove the bracket [2].

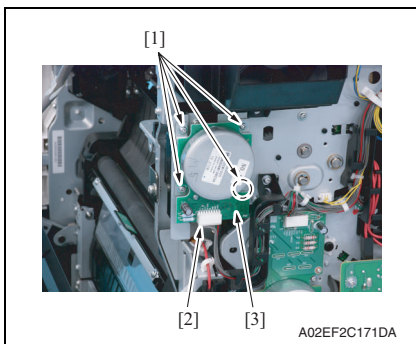

3. Remove four screws [1], disconnect the connector [2], and remove the fusing motor [3].



### 6.3.61 Switchback motor (M6)

1. Remove the paper exit rear cover.  
See P.88

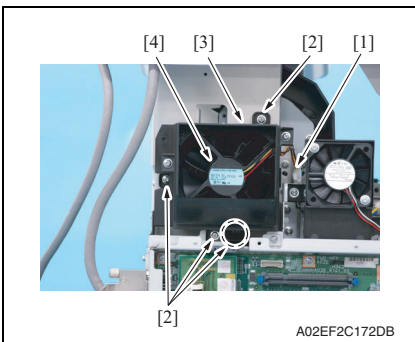

2. Disconnect the connector [1].
3. Remove four screws [2], unhook the tab [3], and remove the paper cooling fan motor assembly [4].

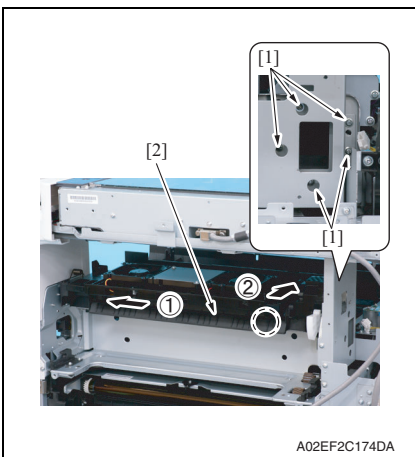

4. Remove five screws [1] and slide the paper exit section assembly [2] in the direction of the arrow.

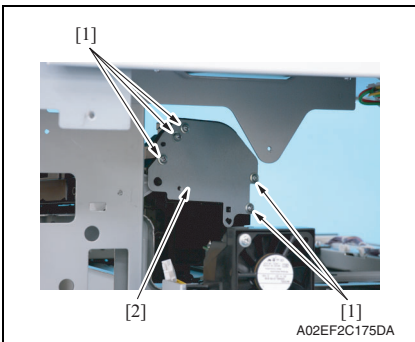

5. Remove five screws [1], and remove the metal plate [2].

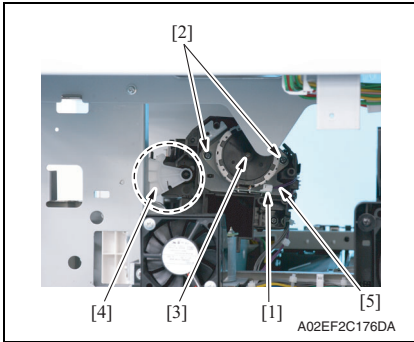

6. Disconnect the connector [1].
7. Remove two screws [2], and remove the switchback motor [3].

**NOTE**

- Care should be taken to avoid letting the lever [4] hit the housing and be damaged.
- Care should be taken to prevent the harness wires [5] from being pulled loose or pulled out of the connector.

**6.3.62 Fusing retraction motor (M12)**

1. Remove the paper exit rear cover.  
[See P.88](#)
2. Remove the protective shield/1 and the protective shield/2.  
[See the steps 1 to 5 of printer control board removing procedure.](#)  
[See P.136](#)

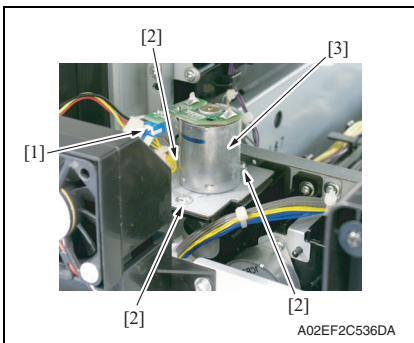

3. Disconnect the connector [1].
4. Remove three screws [2], and remove the fusing retraction motor assy [3].

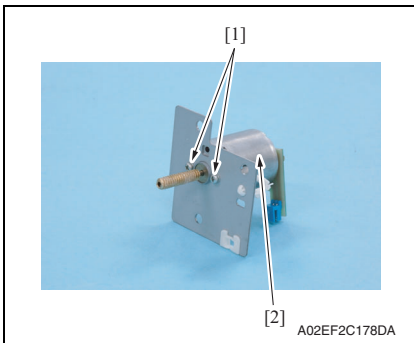

5. Remove two screws [1], and remove the fusing retraction motor [2].

### 6.3.63 Paper feed tray 1 lift-up motor (M8)

1. Remove the tray 1.  
[See P.95](#)
2. Remove the tray 2.  
[See P.95](#)
3. Remove the right front cover/2.  
[See P.85](#)
4. Remove the lower rear cover/1 and the lower rear cover/2.  
[See P.93](#)
5. Remove the protective shield/1 and the protective shield/2.  
[See the steps 1 to 5 of printer control board removing procedure.](#)  
[See P.136](#)

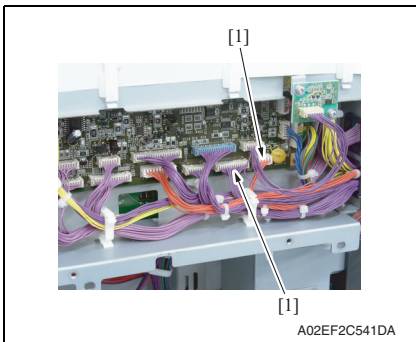

6. Disconnect two connectors (CN10, CN11) [1] on the printer control board.

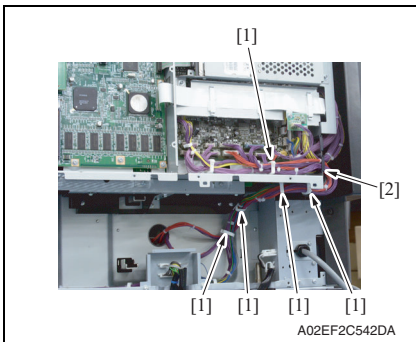

7. Remove the harness from five wire saddles [1] and the edge cover [2].

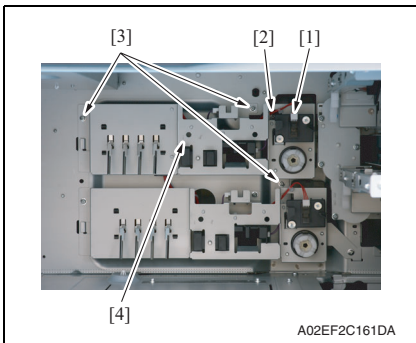

8. Disconnect the connector [1], and remove the harness from the edge cover [2].
9. Remove three screws [3], take out the paper feed tray 1 lift-up motor assy [4].

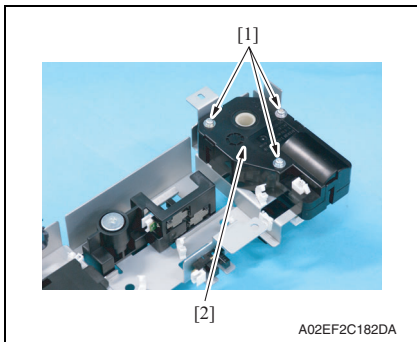

10. Remove three screws [1], and remove the paper feed tray 1 lift-up motor [2].

### 6.3.64 Paper feed tray 2 lift-up motor (M9)

1. Remove the tray 1.  
[See P.95](#)
2. Remove the tray 2.  
[See P.95](#)
3. Remove the right front cover/2.  
[See P.85](#)
4. Remove the lower rear cover/1 and the lower rear cover/2.  
[See P.93](#)
5. Remove the protective shield/1 and the protective shield/2.  
[See the steps 1 to 5 of printer control board removing procedure.](#)  
[See P.136](#)

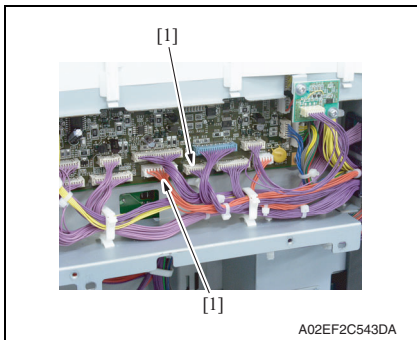

6. Disconnect two connectors (CN7, CN8) [1] on the printer control board

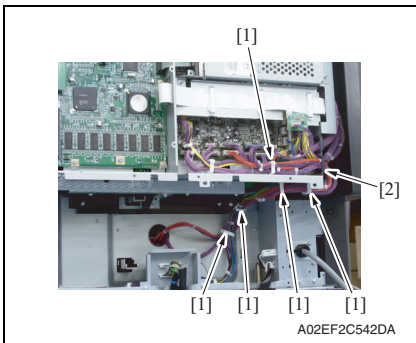

7. Remove the harness from five wire saddles [1] and the edge cover [2].

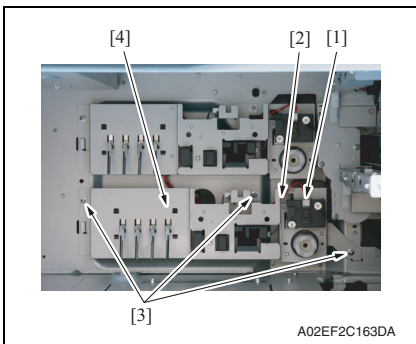

8. Disconnect the connector [1], and remove the harness from the edge cover [2].

9. Remove three screws [3], take out the paper feed tray 2 lift-up motor assy [4].

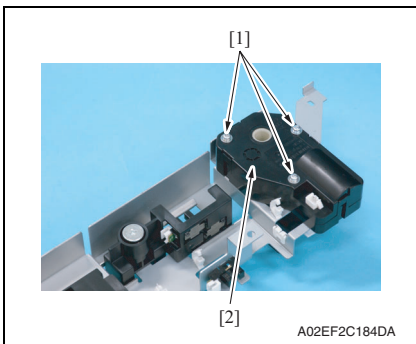

10. Remove three screws [1], and remove the paper feed tray 2 lift-up motor [2].

### 6.3.65 Toner supply motor/CK (M3)

1. Remove the PWB box.  
[See P.139](#)

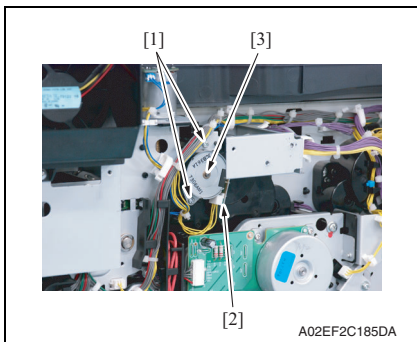

2. Disconnect the connector [2], remove two screws [1], and remove the toner supply motor/CK [3].

### 6.3.66 Toner supply motor/YM (M4)

1. Remove the PWB box.  
[See P.139](#)

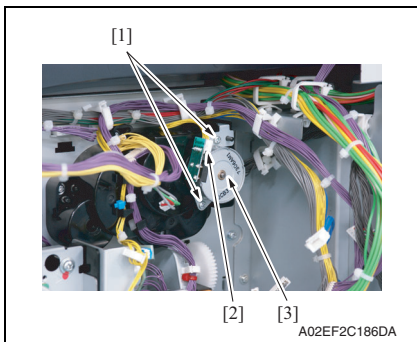

2. Disconnect the connector [2], remove two screws [1], and remove the toner supply motor/YM [3].

### 6.3.67 Paper feed tray 1 paper feed clutch (CL1)

1. Remove the tray 1 paper feed Assy.  
See the steps 1 to 4 of tray 1 feed roller/tray 1 pick-up roller removing procedure.  
See P.24

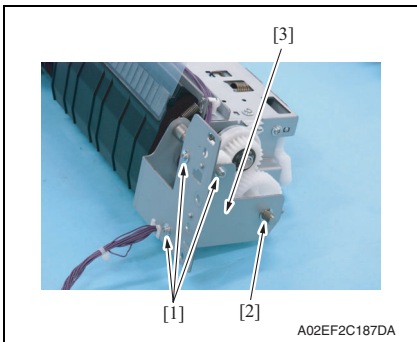

2. Remove three screws [1] and the E-ring [2], and remove the metal plate [3].

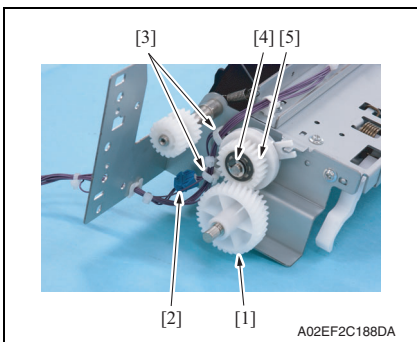

3. Remove the gear [1].
4. Disconnect the connector [2], and remove the harness from two wire saddles [3].
5. Remove the E-ring [4], and remove the paper feed tray 1 paper feed clutch [5].

#### NOTE

- When mounting the paper feed tray 1 paper feed clutch [5], set the convex part of the stopper into the concave part of the paper feed tray 1 paper feed clutch.

### 6.3.68 Paper feed tray 2 vertical transport clutch (CL3)

1. Remove the tray 2 paper feed assy.  
See the steps 1 to 5 of tray 2 feed roller/tray 2 pick-up roller removing procedure.  
See P.28

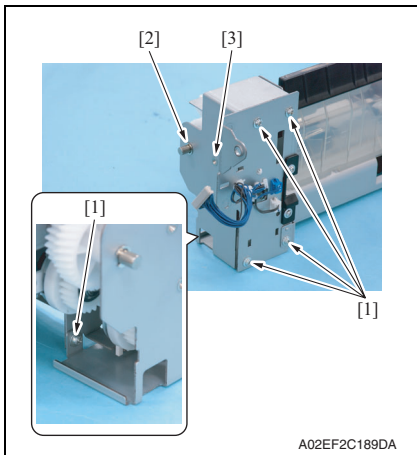

2. Remove five screws [1] and the E-ring [2], and remove the metal plate [3].

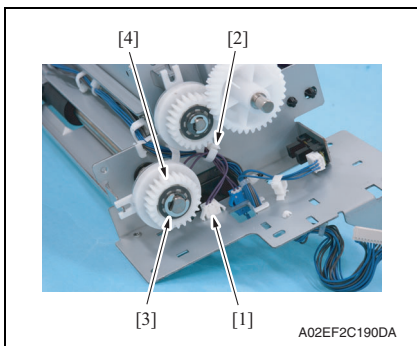

3. Disconnect the connector [1], and remove the harness from the wire saddle [2].
4. Remove the E-ring [3], and remove the paper feed tray 2 vertical transport clutch [4].

#### NOTE

- When mounting the paper feed tray 2 vertical transport clutch [4], set the convex part of the stopper into the concave part of the paper feed tray 2 vertical transport clutch.



### 6.3.69 Paper feed tray 2 paper feed clutch (CL2)

1. Remove the tray 2 paper feed Assy.  
See the steps 1 to 5 of tray 2 feed roller/tray 2 pick-up roller removing procedure.  
See P.28

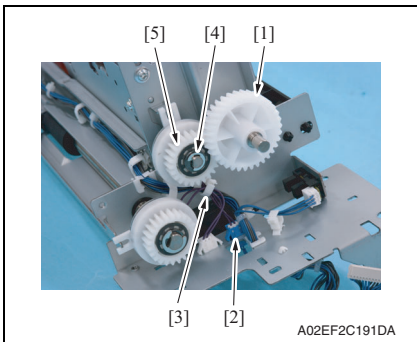

2. Remove the gear [1].
3. Disconnect the connector [2], and remove the harness from the wire saddle [3].
4. Remove the E-ring [4], and remove the paper feed tray 2 paper feed clutch [5].

#### NOTE

- When mounting the paper feed tray 2 paper feed clutch [5], set the convex part of the stopper into the concave part of the paper feed tray 2 paper feed clutch.

### 6.3.70 Manual paper feed clutch (CL4)

1. Remove the manual bypass tray unit.  
See P.103

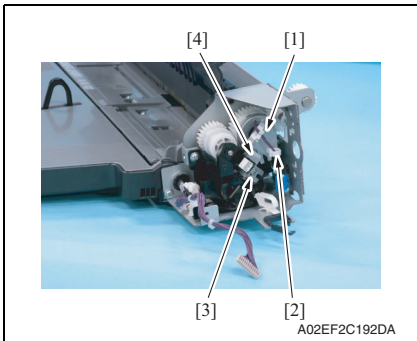

2. Remove the harness from the edge cover [1] and the wire saddle [2], and remove the screw [3].
3. Remove the metal plate [4].

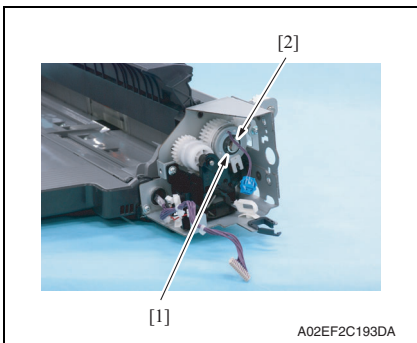

4. Remove the E-ring [1], and remove the manual paper feed clutch [2].

#### NOTE

- When mounting the manual paper feed clutch [2], set the convex part of the stopper into the concave part of the manual paper feed clutch.

### 6.3.71 Transfer belt retraction clutch (CL7)

1. Remove the fusing drive unit.  
[See P.119](#)

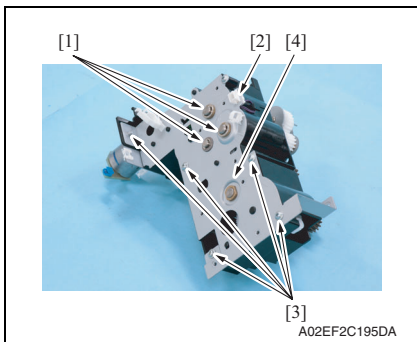

2. Disconnect the connector [2], remove three E-rings [1] and five screws [3], and remove the metal plate [4].

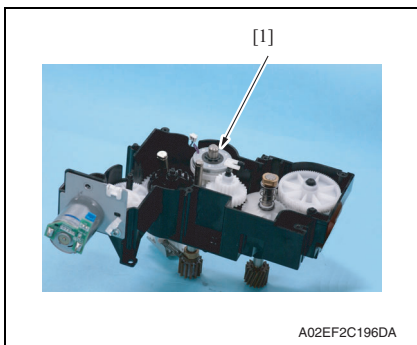

3. Remove the transfer belt retraction clutch [1].

### 6.3.72 Developing clutch/K (CL5)

1. Remove the high voltage unit.  
[See P.142](#)

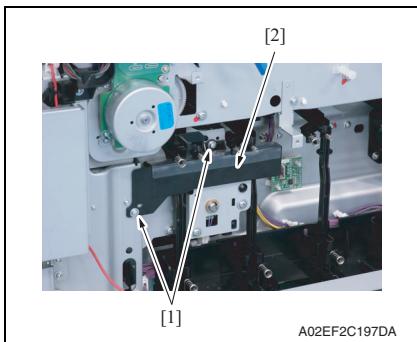

2. Remove two screws [1], and remove the rear handle cover [2].

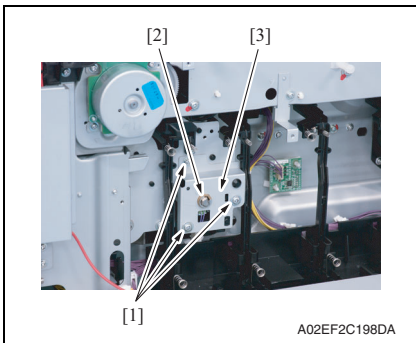

3. Remove three screws [1] and the E-ring [2], and remove the developing clutch/K cover [3].

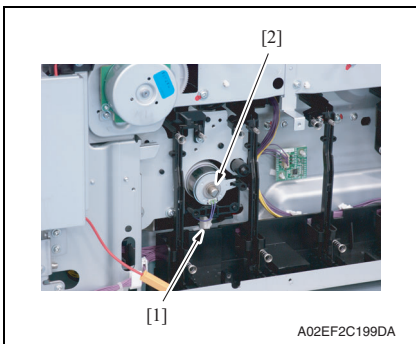

4. Disconnect the connector [1], and remove the developing clutch/K [2].

**6.3.73 Tim. roller clutch (CL6)**

1. Remove the vertical transport unit.  
 See the steps 1 to 7 of IDC registration sensor removing procedure.  
 See P.167

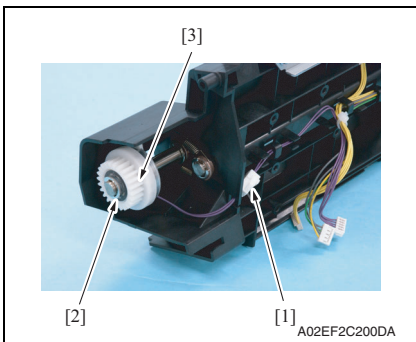

2. Disconnect the connector [1], remove the E-ring [2], and remove the tim. roller clutch [3].

### 6.3.74 IDC registration sensor/MK (IDCS/MK), IDC registration sensor/YC (IDCS/YC)

1. Remove the transfer belt unit.  
[See P.43](#)
2. Remove the manual bypass tray unit.  
[See P.103](#)

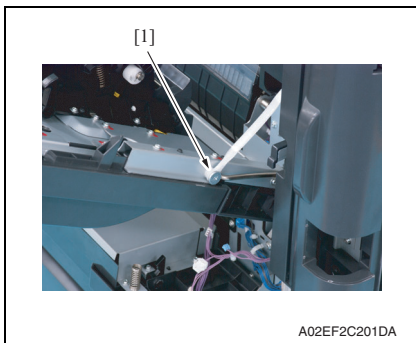

3. Remove the shoulder screw [1].

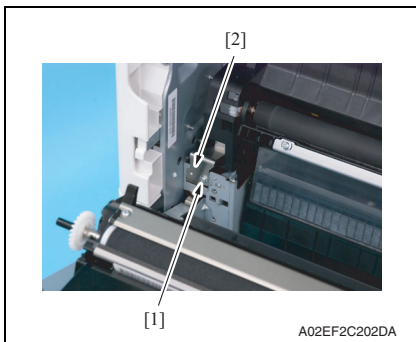

4. Remove the screw [1], and remove the plate spring [2].

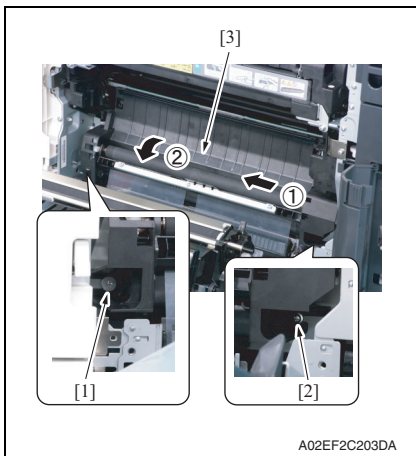

5. Remove the shoulder screw [1] and the screw [2].
6. Remove the vertical transport unit [3] as shown in the left illustration.

#### NOTE

- Since multiple connectors are connected to the backside of the vertical transport assy, do not pull it by force.

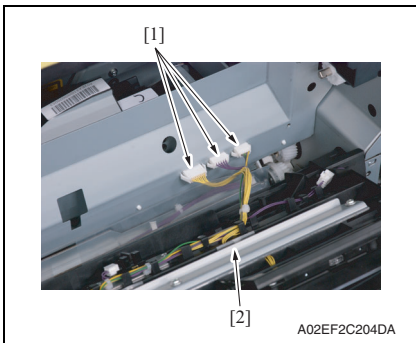

7. Disconnect three connectors [1], and remove the vertical transport unit [2].

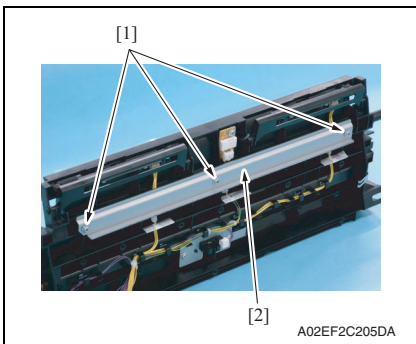

8. Remove three screws [1], and remove the metal plate [2].

**NOTE**

- Both end screws has a spacer. Remove the screws, being careful not to drop the spacers.

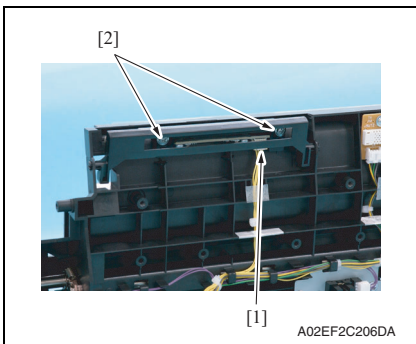

9. Disconnect the connector [1], remove two screws [2], and remove the IDC registration sensor/MK.
10. Repeat steps 8 to 9 to remove IDC registration sensor/YC.

### 6.3.75 Scanner drive cables

#### A. Removal procedure

1. Remove the IR Assy.  
[See P.125](#)
2. Remove the scanner Assy.  
[See P.111](#)
3. Remove the scanner motor.  
[See P.149](#)
4. Remove the original glass moving unit.  
[See P.106](#)

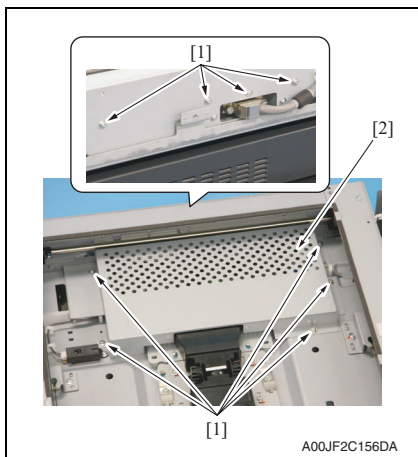

5. Remove nine screws [1], and remove the image processing board protective shield [2].

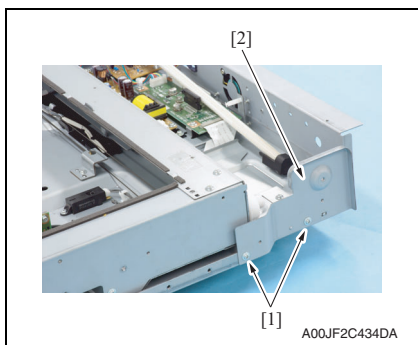

6. Remove two screws [1], and remove the metal plate [2].

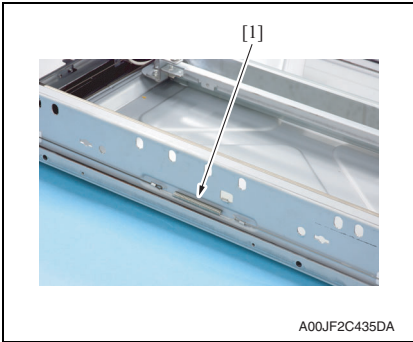

- 7. Remove the hook side spring [1] of the scanner drive cables.

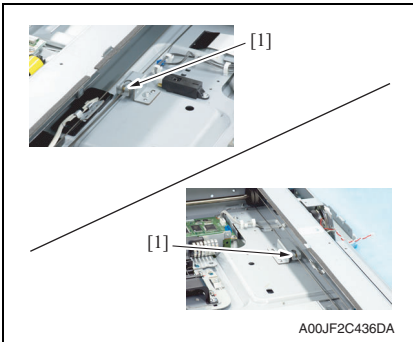

- 8. Remove the bead side [1] of the scanner drive cables from the adjustment anchor.

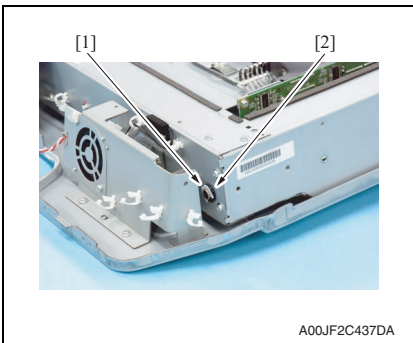

- 9. Remove the C-ring [1] and bearing [2].

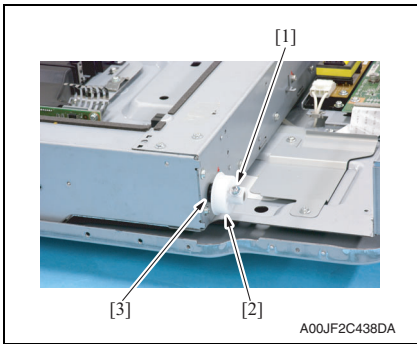

- 10. Remove the screw [1], and remove the scanner drive gear [2].
- 11. Remove the bearing [3].

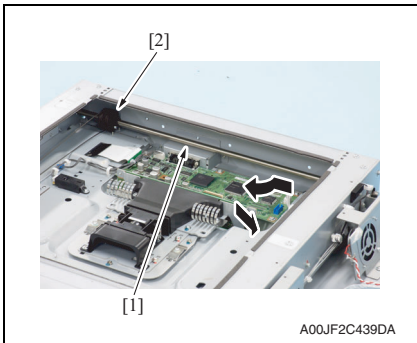

- 12. Remove the shaft [1] and pulley [2].

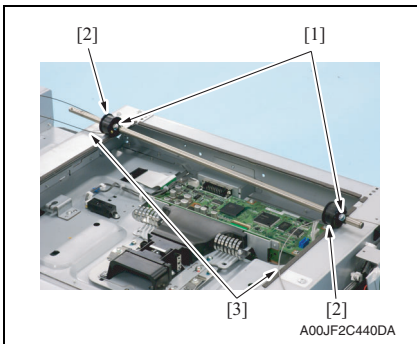

- 13. Remove the screw [1] one each and take out the two pulleys [2] from the shaft.
- 14. Remove the scanner drive cables [3] from each pulley [2].



**B. reinstall procedure**

**(1) Overall figure**

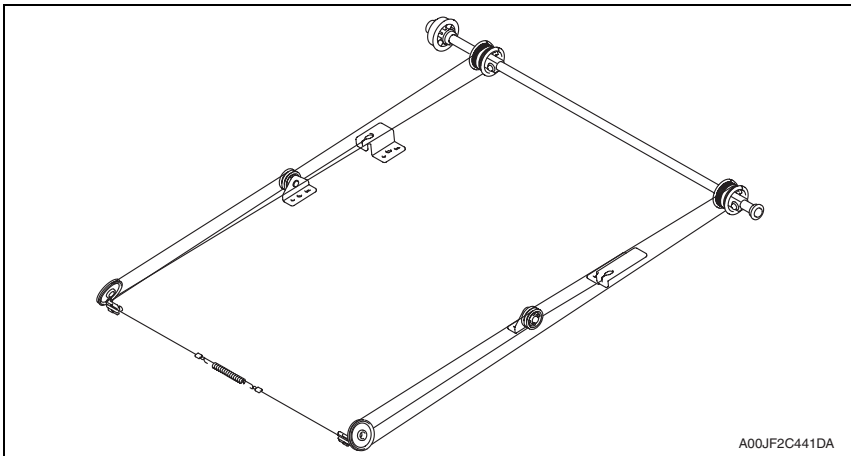

**(2) Winding of the scanner drive cables**

**NOTE**

- The scanner drive cable differs in type between the front (silver) and the rear (black), which are colored differently.

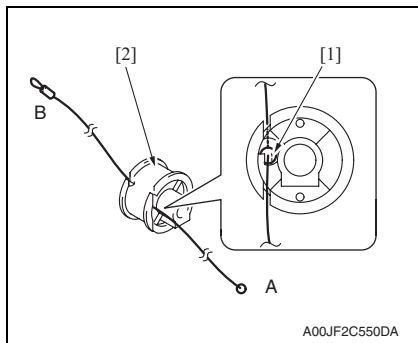

<Front>

1. Set the round bead [1] of the scanner drive cable (silver) to the pulley [2] at the position as shown in the illustration.

**NOTE**

- Make sure that the bead snugly rests in the slit in the pulley.

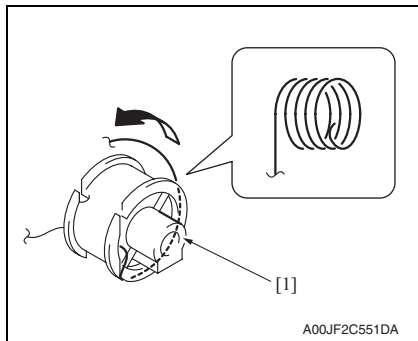

2. Twist the A side scanner drive cable around the pulley [1] starting from the front groove in anticlockwise direction five times.

**NOTE**

- Make sure that no part of the cable rides on the other.

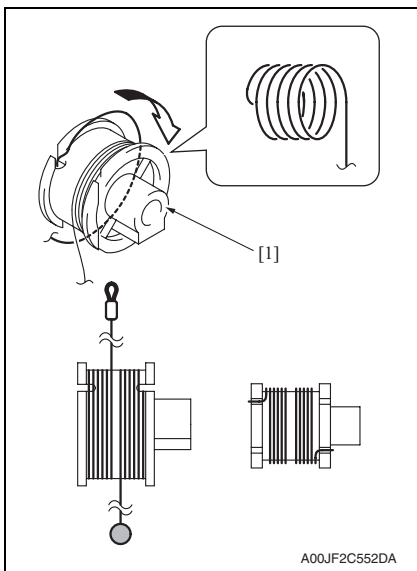

3. Twist the B side scanner drive cable around the pulley [1] starting from the rear groove in clockwise direction five times.

**NOTE**

- Make sure that no part of the cable rides on the other.

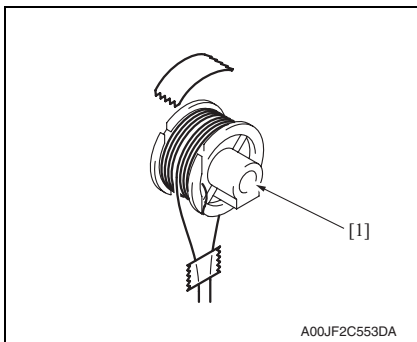

4. Apply the tape to fix the scanner drive cable to the pulley [1].

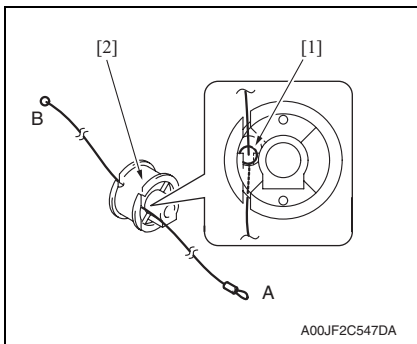

<Rear>

5. Set the round bead [1] of the scanner drive cable (black) to the pulley [2] at the position as shown in the illustration.

**NOTE**

- Make sure that the bead snugly rests in the slit in the pulley.

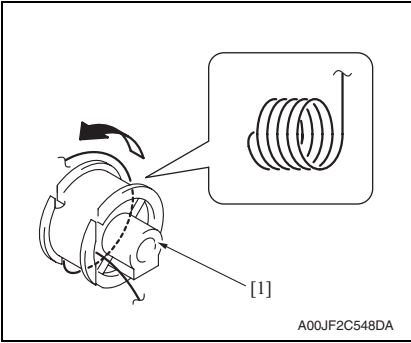

- Twist the B side scanner drive cable around the pulley [1] starting from the rear groove in anticlockwise direction five times.

**NOTE**

- Make sure that no part of the cable rides on the other.

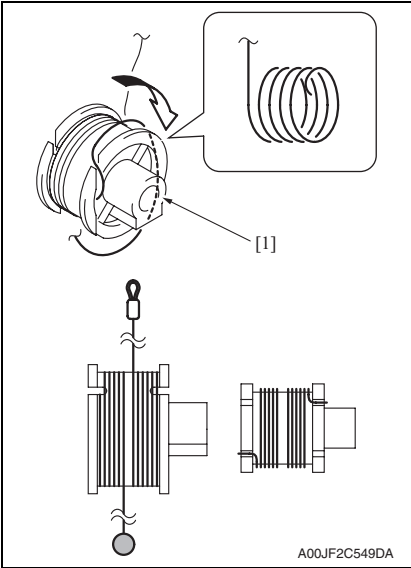

- Twist the A side scanner drive cable around the pulley [1] starting from the front groove in clockwise direction five times.

**NOTE**

- Make sure that no part of the cable rides on the other.

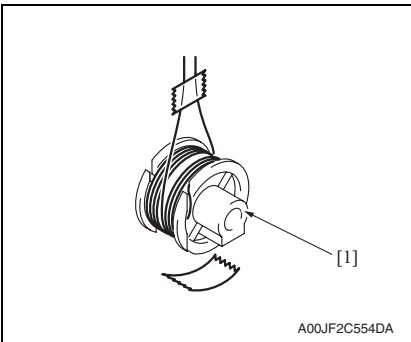

- Apply the tape to fix the scanner drive cable to the pulley [1].

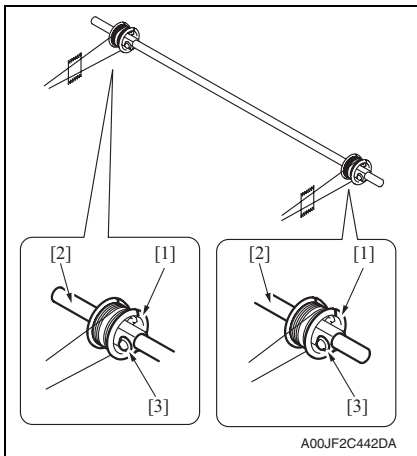

9. Put the front/rear pulleys [1] into the shaft [2], and fix them with one screw each [3].

**NOTE**

- Set the pulley at the direction as shown in the illustration.
- Fix the pulley at the position as shown in the illustration.
- Apply the screw lock on the screw.

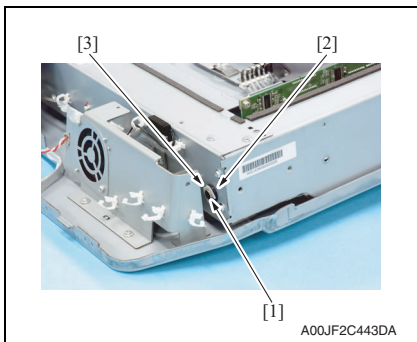

10. Set the shaft [1] and install the bearing [2] and the C-ring [3].

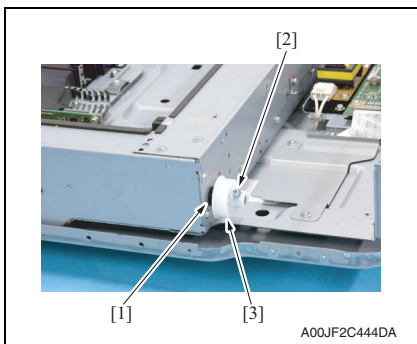

11. Install the bearing [1].  
12. Install the gear [3] with the screw [2].

**NOTE**

- Apply the screw lock on the screw.

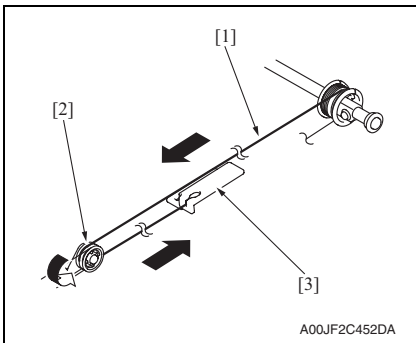

<Front>

13. Place the fixed bead side of the scanner drive cable [1] to the pulley B [2], and place the fixed bead to the adjustment anchor [3].

**NOTE**

- **Make sure to hook the scanner drive cable to the outside groove of the pulley B.**

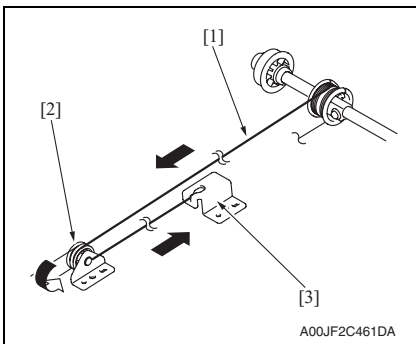

<Rear>

14. Place the fixed bead side of the scanner drive cable [1] to the pulley D [2], and place the fixed bead to the adjustment anchor [3].

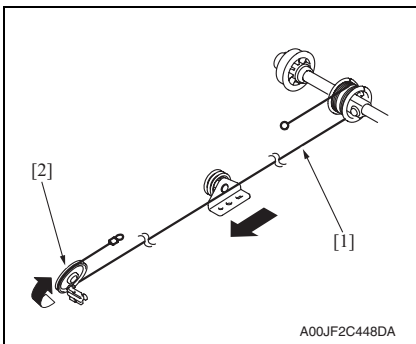

<Rear>

15. Place the hook side of the scanner drive cable [1] to the pulley C [2].

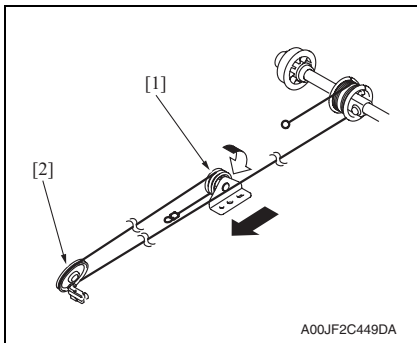

16. Place the scanner drive cable to the pulley D [2] via the pulley C [1].

**NOTE**

- **Make sure to hook the scanner drive cable to the outside groove of the pulley D [2].**

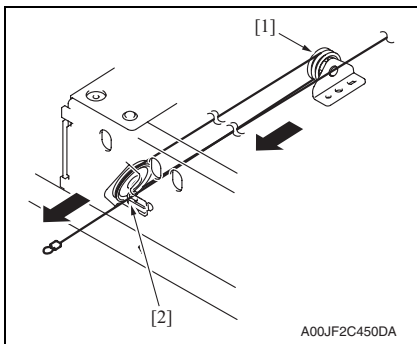

17. Put the scanner drive cable into the IR frame hole [2] via the pulley D [1].

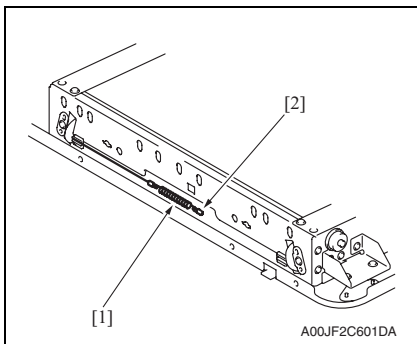

18. Hook the end of the spring [1] to the wire and the other end to the hook [2] on the IR left frame.

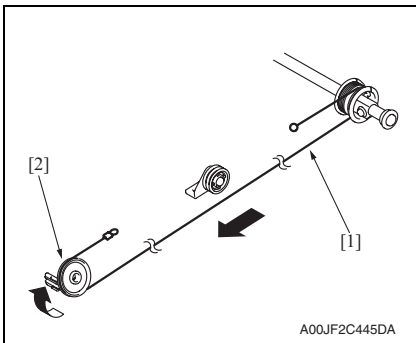

<Front>

19. Place the hook side of the scanner drive cable [1] to the pulley A [2].

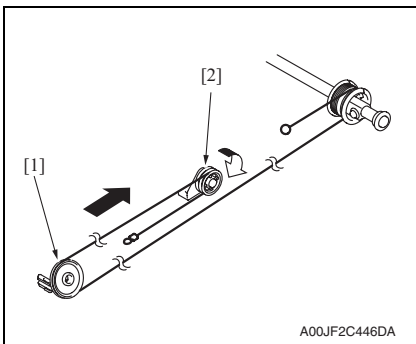

20. Place the scanner drive cable to the pulley B [2] via the pulley A [1].

**NOTE**

- Make sure to hook the scanner drive cable to the outside groove of the pulley B [2].

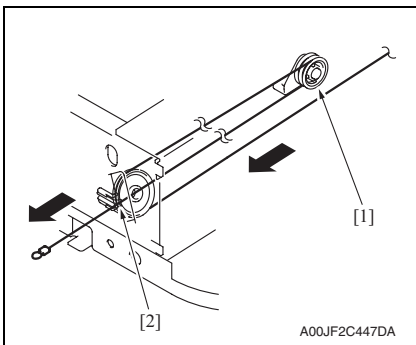

21. Put the scanner drive cable into the IR frame hole [2] via the pulley B [1].

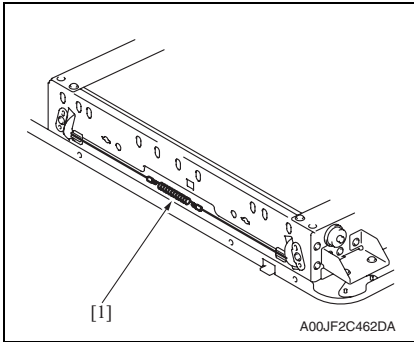

22. Remove the end of the spring [1] from the hook. Hook the end of the spring to the wire coming from the front.

23. Remove the tape that fixes the front/rear pulleys.
24. Adjust the focus positioning of the scanner and mirrors unit.  
[See P.452](#)
25. Adjust the position of the scanner and 2nd/3rd mirrors carriage.  
[See P.453](#)
26. Mount the original glass moving unit, and adjust the height of the original glass moving unit.  
[See P.454](#)
27. Perform the following setting.  
[Service Mode] → [Machine] → [Scan Area] → [Feed Direction Adjustment]  
[See P.355](#)
28. Perform the following setting.  
[Service Mode] → [ADF] → [Read Pos Adj]  
[See P.32 of the DF-611 service manual.](#)



### 6.4 Cleaning procedure

#### NOTE

- The alcohol described in the cleaning procedure represents the ethanol isopropyl alcohol.

#### 6.4.1 Transfer belt unit

1. Remove the transfer belt unit.

See P.43

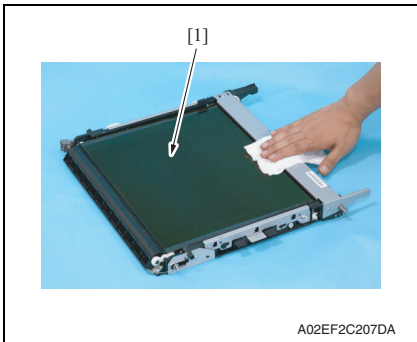

2. Using a cleaning pad, wipe the transfer belt [1].

#### NOTE

- Do not wipe out with water.
- Do not wipe out with any solvents.

#### 6.4.2 PH window Y,M,C,K

1. Open the front door.

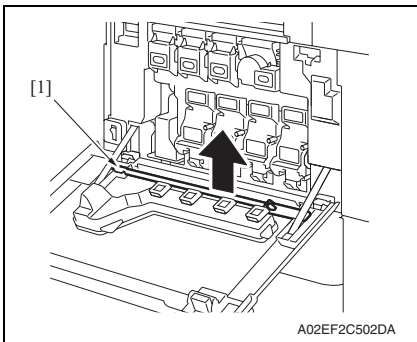

2. Remove the PH window cleaning jig [1] from the front door.

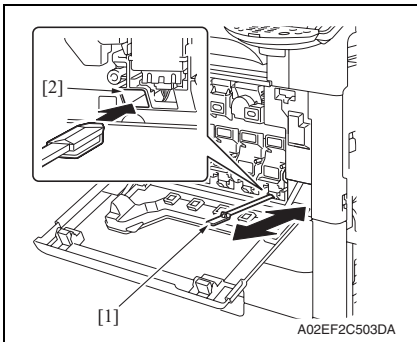

3. Insert the PH window cleaning jig [1] to the cleaning port [2] and clean it by putting the jig back and forth a couple times.

#### NOTE

- Clean every PH window of Y,M,C,K.

### 6.4.3 Tray 1 feed roller, tray 1 pick-up roller, tray 1 separation roller

1. Remove the tray 1 paper feed assy.

See the steps 1 to 4 of tray 1 feed roller/tray 1 pick-up roller removing procedure.  
See P.24

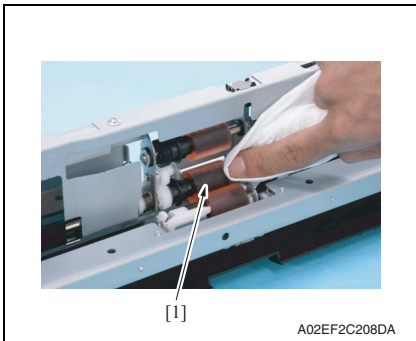

2. Using a cleaning pad dampened with alcohol, wipe the tray 1 feed roller [1] clean of dirt.

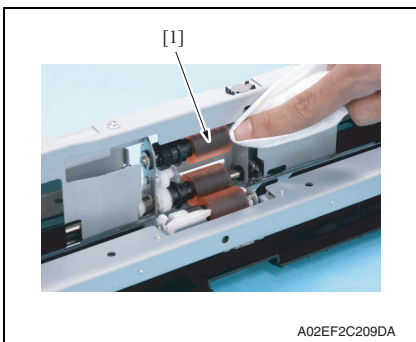

3. Using a cleaning pad dampened with alcohol, wipe the tray 1 pick-up roller [1] clean of dirt.

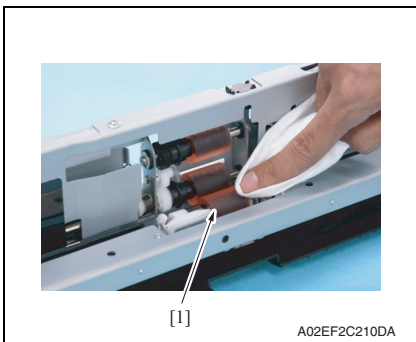

4. Using a cleaning pad dampened with alcohol, wipe the tray 1 separation roller [1] clean of dirt.

### 6.4.4 Tray 2 feed roller, tray 2 pick-up roller, tray 2 separation roller

1. Remove the tray 2 paper feed assy.  
See the steps 1 to 5 of tray 2 feed roller/tray 2 pick-up roller removing procedure.  
See P.28

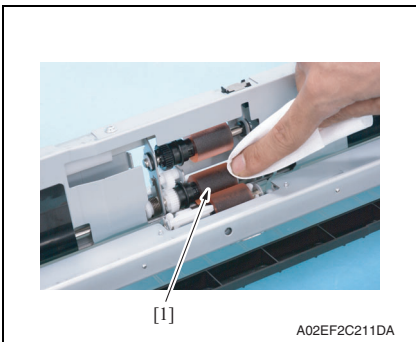

2. Using a cleaning pad dampened with alcohol, wipe the tray 2 feed roller [1] clean of dirt.

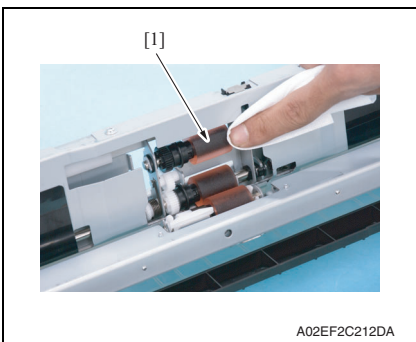

3. Using a cleaning pad dampened with alcohol, wipe the tray 2 pick-up roller [1] clean of dirt.

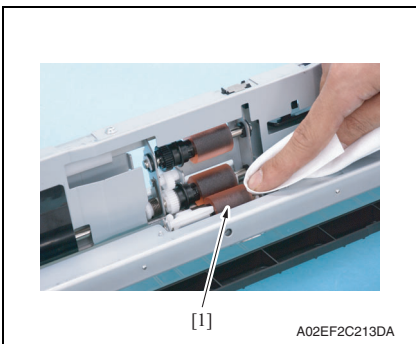

4. Using a cleaning pad dampened with alcohol, wipe the tray 2 separation roller [1] clean of dirt.

### 6.4.5 Tray 2 transport roller

1. Open the vertical transport door.

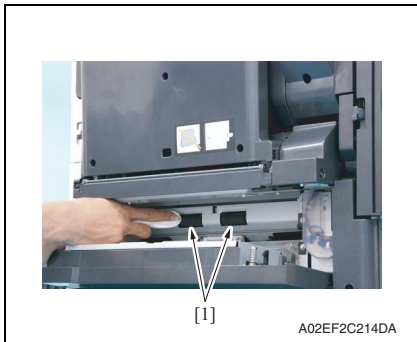

2. Using a cleaning pad dampened with alcohol, wipe the tray 2 transport roller [1] clean of dirt.

### 6.4.6 Manual bypass tray feed roller

1. Remove the manual bypass tray unit.  
[See P.103](#)

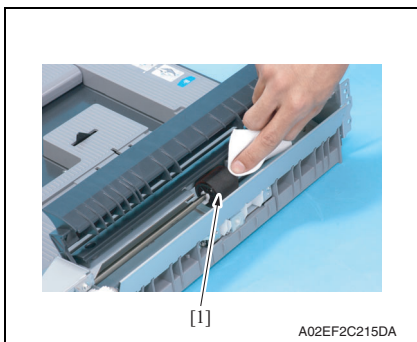

2. Using a cleaning pad dampened with alcohol, wipe the manual bypass tray feed roller [1] clean of dirt.

### 6.4.7 Manual bypass tray separation roller

1. Remove the manual bypass tray separation roller assy.  
[See P.34](#)

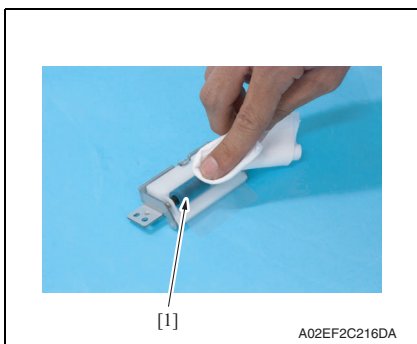

2. Using a cleaning pad dampened with alcohol, wipe the manual bypass tray separation roller [1] clean of dirt.

### 6.4.8 Original glass

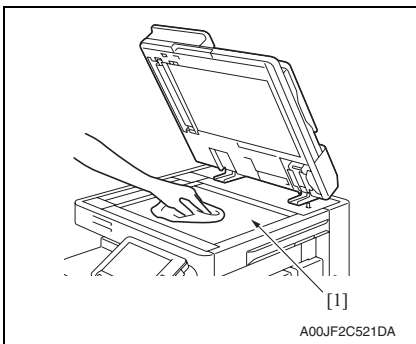

1. Using a cleaning pad dampened with alcohol, wipe the original glass [1] clean of dirt.

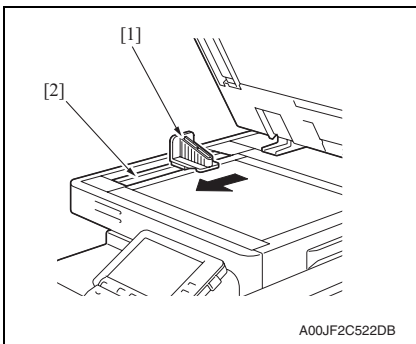

2. Clean the slit glass [2] with the cleaner [1].

### 6.4.9 Scanner rails

1. Remove the original glass.  
[See P.90](#)

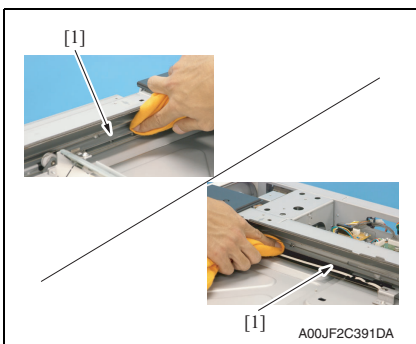

2. Using a cleaning pad dampened with alcohol, wipe the scanner rails [1] clean of dirt.

**NOTE**

- **Apply lubricant after cleaning.**

### 6.4.10 Mirrors (1st/2nd/3rd)

1. Remove the original glass.  
See P.90

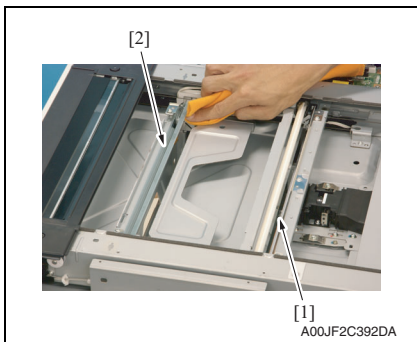

2. Using a cleaning pad dampened with alcohol, wipe the mirror 1 [1] and mirror 2/3 [2].

### 6.4.11 Lens

1. Remove the original glass.  
See P.90

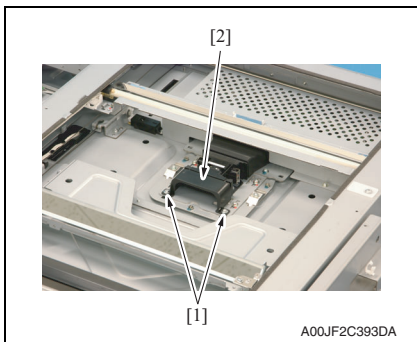

2. Remove two screws [1] and lens cover [2].

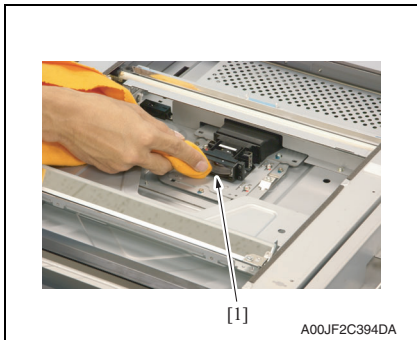

3. Using a cleaning pad dampened with alcohol, wipe the lens [1] clean of dirt.

### 6.4.12 CCD sensor

1. Remove the original glass.  
See P.90

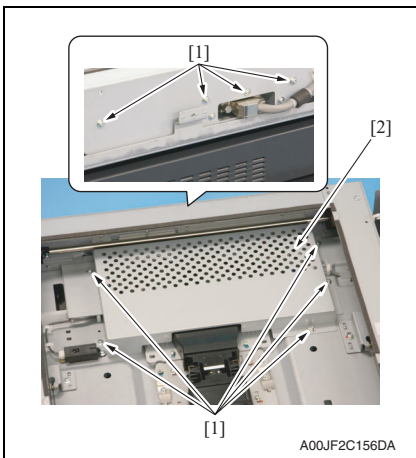

2. Remove nine screws [1], and remove the image processing board protective shield [2].

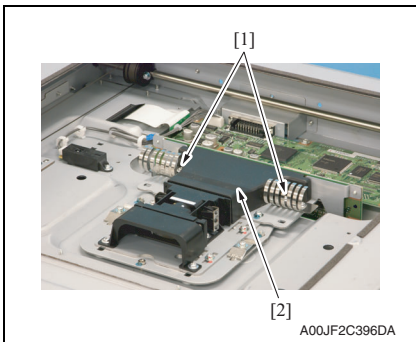

3. Remove two screws [1], and remove the CCD sensor cover [2].

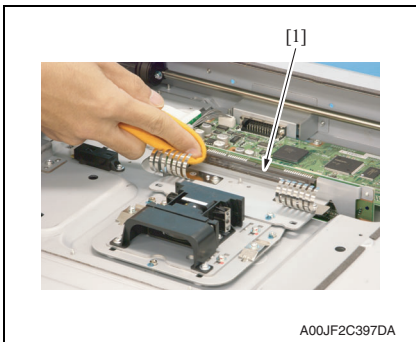

4. Using a cleaning pad dampened with alcohol, wipe the CCD sensor [1] clean of dirt.

### 6.5 Mount the original size detection 2 sensor (PS205)

1. Remove the original glass.  
See P.90

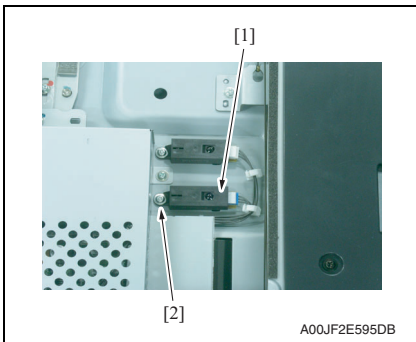

2. Using the screw [2], mount the original size detection 2 sensor (PS205) [1] and fix it.

<How to set the harness>

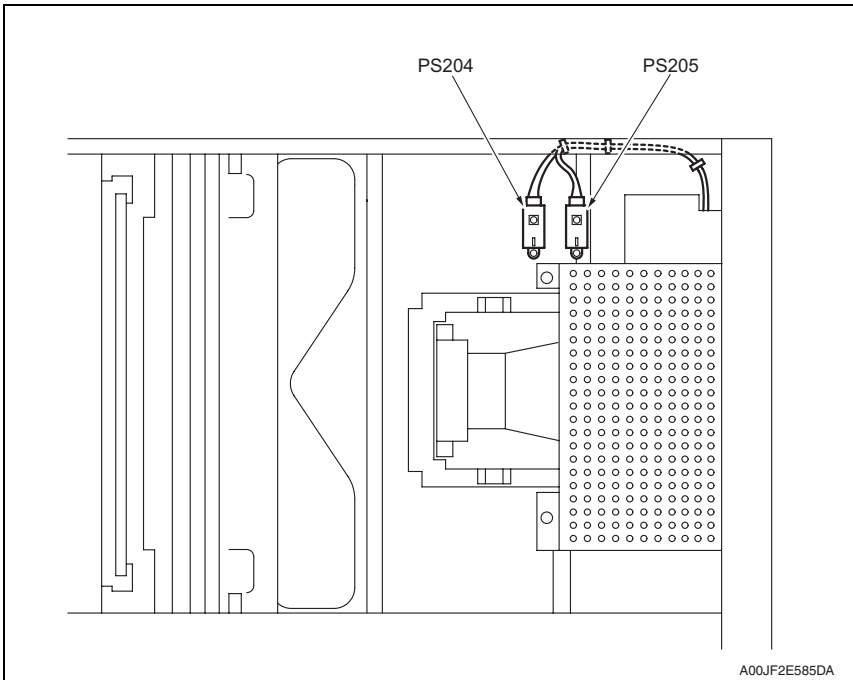



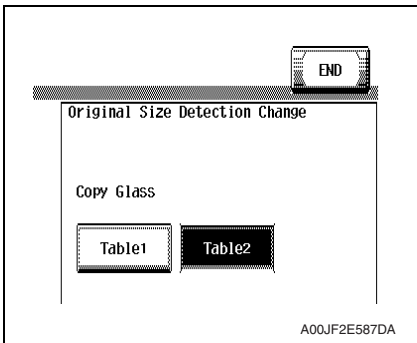

3. Select [Service Mode] → [System 1] → [Original Size Detection], and set the original glass to [Table2].

4. Select [Service Mode] → [Machine] → [Org. Size Detecting Sensor Adj].  
See P.346

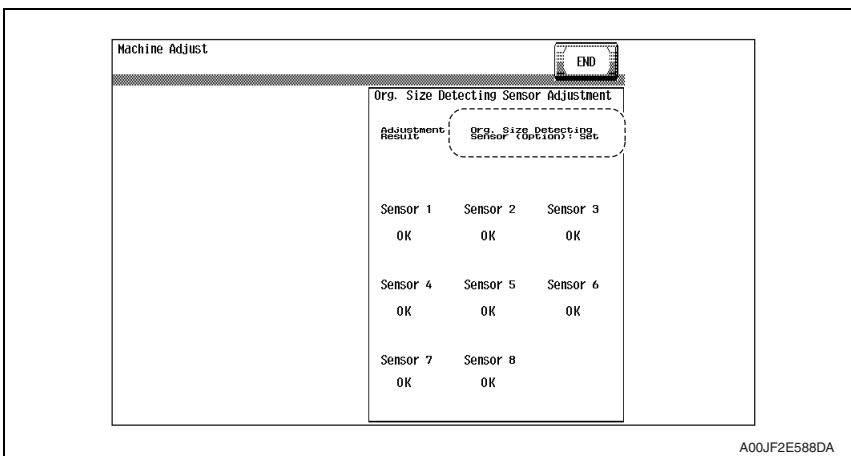

5. Check to make sure that the [Org. Size Detecting Sensor (Option): Set] is displayed on the original size detection sensor adjustment screen.

## 6.6 Option counter

### 6.6.1 Installation method for the key counter

1. Remove the IR front cover.

See P.90

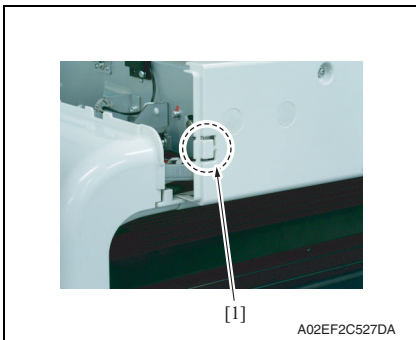

2. Remove the knockouts [1] on the IR right cover.

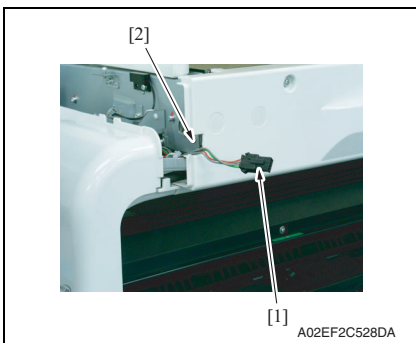

3. Run the key counter harness [1] out through the hole [2] on the IR right cover.

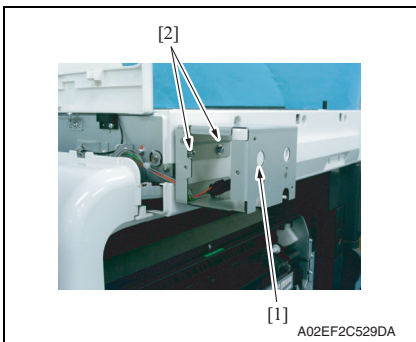

4. Using two screws [2], secure the counter mounting bracket [1].

#### NOTE

- Secure the counter mounting bracket passing the connector into the bracket.
- Use the four long screws (9646 0418 14: M4 x 18) in the key counter kit to secure the counter mounting bracket.

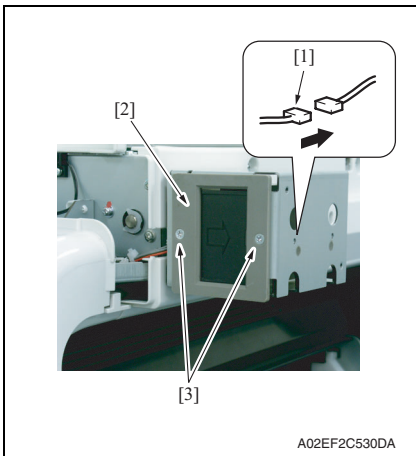

5. Connect the key counter socket connector [1].
6. Using two screws [3], secure the counter socket [2].

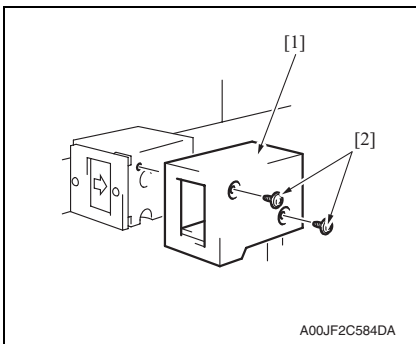

7. Using two screws [2], secure the key counter cover [1].

8. Select [Service Mode] → [Billing Setting] → [Management Function Choice] → [Key Counter Only], [Vendor 1 + Key Counter] or [Vendor 2 + Key Counter]. Set color mode and message.  
 For details on setting, see "Adjustment/Setting."  
 See P.442

# Adjustment/Setting

## 7. How to use the adjustment section

- “Adjustment/Setting” contains detailed information on the adjustment items and procedures for this machine.
- Throughout this “Adjustment/Setting,” the default settings are indicated by “ ”.

### Advance checks

- Before attempting to solve the customer problem, the following advance checks must be made. Check to see if:
  - The power supply voltage meets the specifications.
  - The power supply is properly grounded.
  - The machine shares the power supply with any other machine that draws large current intermittently (e.g., elevator and air conditioner that generate electric noise).
  - The installation site is environmentally appropriate: high temperature, high humidity, direct sunlight, ventilation, etc.; levelness of the installation site.
  - The original has a problem that may cause a defective image.
  - The density is properly selected.
  - The original glass, slit glass, or related part is dirty.
  - Correct paper is being used for printing.
  - The units, parts, and supplies used for printing (developer, PC drum, etc.) are properly replenished and replaced when they reach the end of their useful service life.
  - Toner is not running out.

### CAUTION

- **To unplug the power cord of the machine before starting the service job procedures.**
- **If it is unavoidably necessary to service the machine with its power turned ON, use utmost care not to be caught in the scanner cables or gears of the exposure unit.**
- **Special care should be used when handling the fusing unit which can be extremely hot.**
- **The developing unit has a strong magnetic field. Keep watches and measuring instruments away from it.**
- **Take care not to damage the PC drum with a tool or similar device.**
- **Do not touch IC pins with bare hands.**

# 8. Utility Mode

## 8.1 Touch Panel Adjustment

Functions	<ul style="list-style-type: none"> <li>To adjust the position of the touch panel display</li> </ul>
Use	<ul style="list-style-type: none"> <li>Make this adjustment if the touch panel is slow to respond to a pressing action.</li> <li>Use during the setup procedure.</li> </ul>
Setting/ Procedure	<ol style="list-style-type: none"> <li>Press the Accessibility key.</li> <li>Touch [Touch Panel Adj.].</li> <li>Using the tip of a pen or similar object, touch the four keys (+) on the screen in sequence. <ul style="list-style-type: none"> <li>These crosses may be touched in any order; but be sure to touch the center of each cross.</li> <li>Use care not to damage the screen surface with the tip of the pen.</li> </ul> </li> </ol> <div data-bbox="285 502 927 890" data-label="Image"> </div> <p style="text-align: right; font-size: small;">A00JF3E532DA</p> <ol style="list-style-type: none"> <li>Touching all four crosses will turn the Start key ON in blue.</li> <li>Press the Start key.</li> </ol>

## 8.2 Utility Mode function tree

\* The function tree is shown to comply with the format displayed on the screen.

### NOTE

- **Keys displayed on screens are different depending on the setting.**
- **For displaying the keys with \*, \*\* marks, see “Administrator Security Level.”**  
See P.320
- **For displaying the keys with \*\*\* marks, see “Administrator Feature Level.”**  
See P.438

Utility Mode			Ref. page		
One-Touch/ User Box Registration	Create One-Touch destination	Address Book	E-mail	P.204	
			User Box	P.204	
			Fax	P.204	
			PC (SMB)	P.204	
			FTP	P.204	
			WebDAV	P.205	
			IP Address Fax	P.205	
			Internet Fax	P.205	
		Group	P.205		
		E-mail Setting	E-mail Subject	P.205	
	E-mail Body		P.206		
	Create User Box	Public/Personal User Box		P.206	
		Bulletin Board User Box		P.206	
		Relay User Box		P.206	
	Limiting Access to Destina- tions	Apply Levels/ Groups to Destinations	Address Book	P.207	
Group			P.207		
Program			P.207		
User Settings	System Settings	Language Selection		P.208	
		Measurement Unit Settings		P.208	
		Paper Tray Settings	Auto Tray Selection Settings		P.208
			Auto Tray Switch ON/OFF		P.208
			No Matching Paper in Tray Setting		P.208
			Print Lists		P.209
		Auto Color Level Adjust.		P.209	
		Power Save Settings*	Low Power Mode Settings*		P.209
			Sleep Mode Settings*		P.210
		Output Settings**	Print/Fax Out- put Settings**	Print**	P.210
				Fax**	
			Output Tray Settings**		P.210
			Bin Setting **		P.211
AE Level Adjustment**		P.211			
Auto Paper Select for Small Original		P.211			
Blank Page Print Settings		P.212			

Utility Mode			Ref. page	
User Settings	Custom Display Settings	Copier Settings	Default Tab	P.212
			Shortcut Key 1	P.212
			Shortcut Key 2	
		Scan/Fax Settings	Default Tab	P.212
			Program Default	P.213
			Address Book Index Default	P.213
			Shortcut Key 1	P.213
			Shortcut Key 2	
			Default Address Book	P.213
		Copy Screen	Copy Operating Screen	P.214
		Fax Active Screen	TX Display	P.214
			RX Display	P.214
		Color Selection Settings		P.214
		Left Panel Display Default		P.215
	Search Option Settings		P.215	
	Copier Settings	Auto Booklet ON when Fold & Staple	P.215	
		Auto Zoom for Combine/Booklet	P.215	
		Auto Sort/Group Selection	P.216	
		Default Copy Settings	P.216	
		Default Enlarge Display Settings	P.217	
		When AMS Direction is Incorrect	P.217	
		Separate Scan Output Method	P.217	
		Enlargement Rotation	P.218	
		Auto Zoom (Platen)*	P.218	
		Auto Zoom (ADF)*	P.218	
		Specify Default Tray when APS Off*	P.218	
		Select Tray for Insert Sheet*	P.219	
		Print Jobs During Copy Operation	P.219	
		Automatic Image Rotation**	P.219	
	Scan/Fax Settings	JPEG Compression Level	P.219	
		Black Compression Level	P.220	
		TWAIN Lock Time	P.220	
		Default Scan/Fax Settings	P.220	
Default Enlarge Display Settings		P.221		
Compact PDF Compression Level		P.221		
Printer Settings	Basic Settings	PDL Setting	P.221	
		Number of Copies	P.222	
		Original Direction	P.222	
		Spool Print Jobs in HDD before RIP	P.222	
		A4/A3 ↔ LTR/LGR Auto Switch	P.222	
		Banner Sheet Setting	P.222	
		Binding Direction Adjustment	P.223	

Utility Mode				Ref. page	
⚠ User Settings	Printer Settings	Basic Settings	Line Width Adjustment	P.223	
		Paper Setting	Paper Tray	P.223	
			Paper Size	P.223	
			2-Sided Print	P.223	
			Binding Position	P.224	
			Staple	P.224	
			Punch	P.224	
			Banner Paper Tray	P.224	
		PCL Settings	Font Settings	P.224	
			Symbol Set	P.225	
			Font Size	P.225	
			Line/Page	P.225	
			CR/LF Mapping	P.225	
		PS Setting	Print PS Errors	P.225	
			ICC Profile Settings	Photo-RGB Color	P.226
				Photo-Output Profile	
				Text-RGB Color	
				Text-Output Profile	
				Figure/Table Graph-RGB Color	
	Figure/Table Graph-Output Profile				
	Simulation-Profile				
	XPS Settings	Verify XPS Digital Signature	P.226		
	Print Reports	Configuration Page	P.226		
Demo Page					
PCL Font List					
PS Font List					
Change Password				P.227	
Change E-mail Address				P.227	
Administrator Settings	System Settings	Power Save Settings	Low Power Mode Settings	P.228	
			Sleep Mode Settings	P.228	
			Power Save Key	P.228	
			Enter Power Save Mode	P.229	
		Output Settings	Print/Fax Output Settings	Print	P.229
				Fax	
			Output Tray Settings	P.229	
	Bin Setting	P.230			
	Shift Output Each Job	P.230			
	Date/Time Settings	P.230			
Daylight Saving Time	P.230				



bizhub C353/C253/C203

Adjustment / Setting



Utility Mode			Ref. page			
Administrator Setting	System Setting	Weekly Timer Settings	Weekly Timer ON/OFF Settings	P.231		
			Time Settings	P.231		
			Date Settings	P.231		
			Select Time for Power Save	P.231		
			Password for Non-Business Hours	P.231		
		Restrict User Access	Restrict Access to Job Settings	Copy Program Lock Settings	P.232	
				Delete Saved Copy Program	P.232	
				Changing Job Priority	P.232	
				Delete Other User Jobs	P.232	
				Registering and Changing Addresses	P.232	
				Changing Zoom Ratio	P.233	
				Changing the "From" Address	P.233	
				Change Registered Overlay	P.233	
		Restrict Operation	Restrict Broadcasting	P.233		
		Expert Adjustment	Printer Adjustment	AE Level Adjustment	P.233	
				Leading Edge Adjustment	Leading Edge Adjustment	P.234
					Centering	P.235
					Leading Edge Adjustment (Duplex Side 2)	P.236
					Centering (Duplex 2nd Side)	P.237
					Erase Leading Edge ***	P.237
					Vertical Adjustment ***	P.238
					Media Adjustment	P.239
				Finisher Adjustment	Center Staple Position	P.239
					Half-Fold Position	
					Punch Horizontal Position Adjustment	
					Punch Regist Loop Size Adjustment	
				Density Adjustment	Thick -Yellow	P.240
Thick - Magenta						
Thick - Cyan						
Thick - Black						
Black Image Density	P.240					
Image Stabilization			P.240			

Utility Mode				Ref. page		
Administrator Setting	System Setting	Expert Adjustment	Color Registration Adjust	Color Registration Adjust (Yellow)	P.242	
				Color Registration Adjust (Magenta)		
				Color Registration Adjust (Cyan)		
			Gradation Adjustment	Copy	P.243	
				Printer (Gradation)		
				Printer (Resolution)		
			Scanner Area ***	Scanner Adjustment: Leading Edge ***	P.245	
				Scanner Adjustment: Centering ***	P.246	
				Horizontal Adjustment ***	P.247	
				Vertical Adjustment ***	P.248	
			ADF Adjustment ***	Centering***	P.248	
				Original Stop Position***		
		Centering Auto Adjustment***				
		Auto Adj. of Stop Position***				
		Line Detection	Prior Detection Setting	P.249		
			Detection While Feeding Setting	P.250		
		List/Counter	Management List	Job Settings List	P.250	
			Paper Size/Type Counter		P.250	
			Meter Counter List		P.251	
			Check Consumables List		P.251	
		Reset Settings	System Auto Reset		P.251	
			Auto Reset		P.251	
			Job Reset	When Account is changed		P.252
				When Original is set on ADF		P.252
			NEXT JOB	Staple Setting	P.252	
				Original Set/ Bind Direction	P.252	
		Reset Data After Job		P.252		
User Box Settings	Delete Unused User Box		P.253			
	Delete Secure Print Documents		P.253			
	Auto Delete Secure Documents		P.253			
	Encrypted PDF Delete Time		P.253			
	Touch & Print Delete Time		P.253			
	Document Hold Setting		P.253			
	External Memory Function Settings		P.254			

bizhub C353/C253/C203

Adjustment / Setting

bizhub C353/C253/C203

Adjustment / Setting

Utility Mode				Ref. page	
Administrator Settings	System Setting	Standard Size Setting***	Original Glass Original Size Detect***	P.254	
			Foolscap Size Setting***	P.254	
		Stamp Settings	Header/Footer Settings		P.254
			Fax TX Settings		P.255
		Blank Page Print Settings			P.255
		Application Key Settings			P.255
	Administrator/Machine Settings	Administrator Registration			P.255
		Input Machine Address			P.255
	One-Touch/User Box Registration	Create One-Touch Destination	Address Book	E-mail	P.256
				User Box	P.256
				Fax	P.256
				PC (SMB)	P.256
				FTP	P.256
				WebDAV	P.256
				IP Address Fax	P.257
				Internet Fax	P.257
		Group	P.257		
		E-mail Settings	E-mail Subject	P.257	
			E-mail Body	P.257	
		Create User Box	Public/Personal User Box		P.258
Bulletin Board User Box			P.258		
Relay User Box			P.258		
Annotation User Box			P.258		
One-Touch/User Box Registration List		Address Book List		P.259	
	Group List		P.259		
	Program List		P.259		
	E-mail Subject/Text List		P.259		
Maximum Number of User Boxes			P.260		
Administrator Settings	User Authentication/Account Track	General Settings		P.260	
		User Authentication Settings	Administrative Setting	User Name List	P.263
				Default Function Permission	P.263
			ID & Print Settings		P.263
			ID & Print Operation Settings		P.264
		User Registration		P.264	
		User Counter		P.264	
		Account Track Settings	Account Track Registration		P.265
	Account Track Counter		P.265		
	Print without Authentication			P.265	
	Print Counter List			P.265	
External Server Settings			P.266		

Utility Mode			Ref. page		
Administrator Settings	User Authentication/ Account Track	Limiting Access to Destinations	Create Group	P.266	
			Apply Levels/Groups to Destinations	P.266	
			Apply Levels/Groups to Users	P.266	
		Authentication Device Settings	General Settings	P.267	
			Touch & Print Setting	P.267	
			Logoff Settings	P.267	
	Network Settings	TCP/IP Settings		P.267	
		NetWare Settings		P.273	
		HTTP Server Settings		P.276	
		FTP Settings		P.277	
		SMB Settings		P.279	
		LDAP Settings	Enabling LDAP		P.281
			Setting Up LDAP		P.281
			Default LDAP Server Setting		P.284
		E-mail Settings	E-mail TX (SMTP)		P.284
			E-mail RX (POP)		P.287
			S/MIME Communication Settings		P.289
		SNMP Settings		P.290	
		AppleTalk Settings		P.292	
		Bonjour Setting		P.293	
TCP Socket Settings		P.293			
Network Fax Settings		Network Fax Function Settings	IP Address Fax Function	P.294	
			Internet Fax Function	P.294	
		SMTP TX Settings		P.294	
		SMTP RX Settings		P.295	
		WebDAV Client Settings		P.295	
WebDAV Settings	WebDAV Server Settings		P.296		
	Web Service Common Settings		P.296		
Web Service Settings	Printer Settings		P.297		
	Scanner Settings		P.297		
	Detail Settings	Device Setting		P.298	
Time Adjustment Setting		P.299			
Status Notification Setting		Register Notification Address	P.299		
Total Counter Notification Settings		P.300			
PING Confirmation		P.301			
SLP Setting		P.301			
LPD Setting		P.301			
Prefix/Suffix Setting		ON/OFF Setting		P.301	
		Prefix/Suffix Setting		P.302	
Action for Invalid Certificate		P.302			



bizhub\_C353/C253/C203

Adjustment / Setting



Utility Mode			Ref. page	
Administrator Settings	Copier Settings	Auto Zoom (Platen)	P.302	
		Auto Zoom (ADF)	P.302	
		Specify Default Tray when APS OFF	P.302	
		Select Tray for Insert Sheet	P.302	
		Print Jobs During Copy Operation	P.303	
		Automatic Image Rotation	P.303	
	Printer Settings	USB Timeout	P.303	
		Network Timeout	P.303	
		Print XPS Errors	P.304	
	Fax Settings	Header Information		P.304
		Header/ Footer Position	Header Position	P.304
			Print Receiver's Name	P.304
			Footer Position	P.305
		Line Parameter Setting	Dialing Method	P.305
			Receive Mode	P.305
			Number of RX Call Rings	P.305
			Number of Redials	P.306
			Redial interval	P.306
			Line Monitor Sound	P.306
			Line Monitor Sound Vol.	P.306
		TX/RX Settings	Duplex Print (RX)	P.306
			Letter/Ledger over A4/A3	P.306
			Print Paper Selection	P.307
			Print Paper Size	P.307
			Incorrect User Box No. Entry	P.307
			Tray Selection for RX Print	P.307
			Min. Reduction for RX Print	P.307
			Print Separate Fax Pages	P.308
			File After Polling TX	P.308
	No. of Sets (RX)	P.308		
	Function Settings	Function ON/ OFF Setting	F Code TX	P.308
			Relay RX	P.308
Relay Printing			P.309	
Destination Check Display Function			P.309	
Confirm Address (TX)			P.309	
Confirm Address (Register)		P.309		
Memory RX Setting		P.310		
Closed Network RX		P.310		
Forward TX Setting	P.310			

Utility Mode			Ref. page		
Administrator Settings	Fax Settings	Function Settings	Incomplete TX Hold	P.311	
			PC-Fax RX Setting	P.311	
			TSI User Box Setting	P.311	
		PBX Connection Setting			P.312
		Report Settings	Activity Report		P.312
			TX Result Report		P.312
			Sequential TX Report		P.312
			Timer Reservation TX Report		P.312
			Confidential RX Report		P.313
			Bulletin TX Report		P.313
			Relay TX Result Report		P.313
			Relay Request Report		P.313
			PC-FAX TX Error Report		P.313
			Broadcast Result Report		P.314
			TX Result Report Check		P.314
			Network Fax RX Error Report		P.314
			MDN Message		P.314
			DSN Message		P.314
			Print E-mail Message Body		P.315
		Job Settings List			P.315
		Multi Line Settings	Line Parameter Setting	Dialing Method	P.315
				Number of RX Call Rings	P.315
				Line Monitor Sound	P.316
			Function Settings	PC-FAX TX Setting	P.316
			Multi Lines Settings		P.316
			Sender Fax No.		P.316
		Network Fax Settings	Black Compression Level		P.317
			Internet Fax Self Rx Ability		P.317
			Internet Fax Advanced Settings		P.318
		System Connection	OpenAPI Settings	Access Setting	P.318
				Port Number	P.318
				SSL	P.319
				Authentication	P.319
Call Remote Center			P.319		
Security Settings	Administrator Password		P.319		
	User Box Administrator Setting		P.320		
	Administrator Security Levels		P.320		

bizhub\_C353/C253/C203

Adjustment / Setting

Utility Mode			Ref. page		
Administrator Settings	Security Settings	Security Details	Password Rules	P.321	
			Prohibited Functions When Authentication Error	P.322	
			Confidential Document Access Method	P.323	
			Manual Destination Input	P.323	
			Print Data Capture	P.323	
			Audit Log Settings	P.324	
			Restrict Fax TX	P.324	
			Hide Personal Information	P.324	
			Display Activity Log	P.324	
			Delete Job Log	P.325	
		Enhanced Security Mode			P.325
		HDD Settings	Check HDD Capacity	P.326	
			Overwrite Temporary Data	P.327	
			Overwrite All Data	P.328	
			HDD Lock Password	P.328	
			Format HDD	P.329	
			HDD Encryption Setting	P.329	
		Function Management Settings	Usage Settings for Each Function	P.330	
			Maximum Job Allowance	P.330	
			Network Function Usage Settings	P.330	
			Authentication Time Setting	P.331	
		Stamp Settings	Apply Stamps	P.331	
			Delete Registered Stamp	P.331	
Image Log Transfer Settings			P.332		
Driver Password Encryption Setting			P.332		
License Settings	Get Request Code	P.333			
	Install License	P.333			
	List of Enabled Functions	P.333			
Check Consumable Life	Print List	—			
Banner Printing			P.333		
My Panel Settings	Language Setting	P.334			
	Measurement Unit Setting				
	Copier Settings				
	Scan/Fax Settings				
	Color Selection Setting				
	Main Menu Settings				
	Initial Screen Setting				

Utility Mode			Ref. page
Meter Count	Check Details	Print List	—
		Coverage Rate	—
		Copy	—
		Print	—
		Scan/Fax	—
		Other	—
Remaining Copy Count *1			—



\*1: Displayed after a user or account authentication if maximum limit is set for the number of copies the user or account can make.

### 8.3 Utility Mode function setting procedure

#### 8.3.1 Procedure

1. Press the Utility/Counter key.
2. The Utility Mode screen will appear.

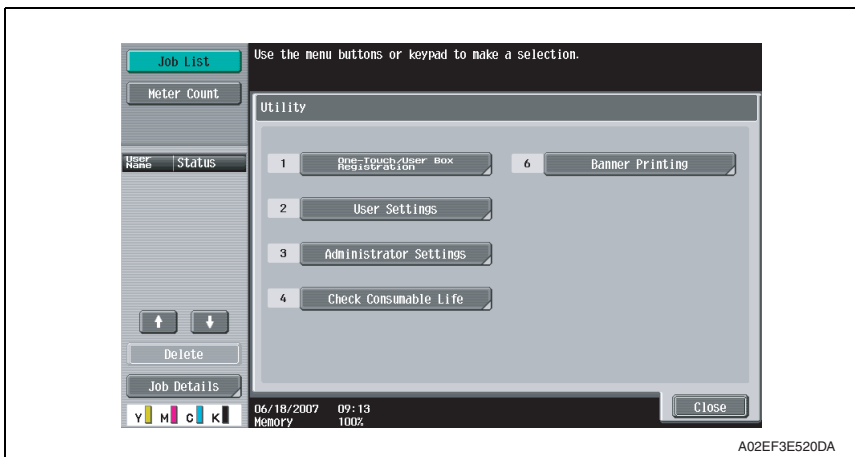

#### 8.3.2 Exiting

- Touch the [Close] key.

#### 8.3.3 Changing the setting value in Utility Mode functions

- Use the [+] / [-] key to enter or change the setting value.
- Use the 10-key pad to enter the setting value.  
(To change the setting value, first press the Clear key before making an entry.)



## 8.4 One-Touch User Box Registration

- In a copier where the user authentication function that uses an external server or MFP is set to ON, when you operate the copier without performing user authentication, this menu is not displayed.
- It will not be displayed when the authentication device is set to “Set” by the following setting.  
[Service Mode] → [Billing Setting] → [Management Function Choice]

### 8.4.1 Create One-Touch destination

#### A. Address Book

##### (1) E-mail

Functions	• To register/change e-mail address to send scanned data.
Use	
Setting/ Procedure	<ul style="list-style-type: none"> <li>• A new address can be registered by touching [New].</li> <li>• Select any displayed address to check, edit or delete the setting.</li> </ul>

##### (2) User Box

- It will not be displayed when the following setting shows that authentication device or the vendor is mounted.  
[Service Mode] → [Billing Setting] → [Management Function Choice]  
(It will be displayed when the key counter is mounted.)

Functions	• To register/change the Box address when storing the scanned data in the box in the hard disk in the main body.
Use	
Setting/ Procedure	<ul style="list-style-type: none"> <li>• A new address can be registered by touching [New].</li> <li>• Select any displayed address to check, edit or delete the setting.</li> <li>• At least one User Box must be registered for registering a Box address.</li> </ul>

##### (3) Fax

Functions	• To register/change the fax destinations.
Use	
Setting/ Procedure	<ul style="list-style-type: none"> <li>• A new address can be registered by touching [New].</li> <li>• Select any displayed address to check, edit or delete the setting.</li> </ul>

##### (4) PC(SMB)

Functions	• To register/change SMB address to send scanned data.
Use	
Setting/ Procedure	<ul style="list-style-type: none"> <li>• A new address can be registered by touching [New].</li> <li>• Select any displayed address to check, edit or delete the setting.</li> </ul>

##### (5) FTP

Functions	• To register/change FTP address to send scanned data.
Use	
Setting/ Procedure	<ul style="list-style-type: none"> <li>• A new address can be registered by touching [New].</li> <li>• Select any displayed address to check, edit or delete the setting.</li> </ul>

**(6) WebDAV**

Functions	<ul style="list-style-type: none"> <li>To register/change WebDAV address to send scanned data.</li> </ul>
Use	
Setting/ Procedure	<ul style="list-style-type: none"> <li>A new address can be registered by touching [New].</li> <li>Select any displayed address to check, edit or delete the setting.</li> </ul>

**(7) IP Address Fax**

- Setting will be available only when [IP Address FAX] is set to “ON” in the following settings.  
 [Administrator Settings] → [Network Settings] → [Network Fax Settings] → [Network Fax Function Settings]

Functions	<ul style="list-style-type: none"> <li>To register/change the IP address fax destination when transmitting the IP address fax data.</li> </ul>
Use	
Setting/ Procedure	<ul style="list-style-type: none"> <li>A new address can be registered by touching [New].</li> <li>Select any displayed address to check, change or delete the setting.</li> </ul>

**(8) Internet Fax**

- Setting will be available only when [Internet FAX] is set to “ON” in the following settings.  
 [Administrator Settings] → [Network Settings] → [Network Fax Settings] → [Network Fax Function Settings]

Functions	<ul style="list-style-type: none"> <li>To register/change the Internet fax address when transmitting the internet fax data.</li> </ul>
Use	
Setting/ Procedure	<ul style="list-style-type: none"> <li>A new address can be registered by touching [New].</li> <li>Select any displayed address to check, change or delete the setting.</li> </ul>

**B. Group**

Functions	<ul style="list-style-type: none"> <li>To register/change a group to send scanned data/fax data simultaneously.</li> </ul>
Use	
Setting/ Procedure	<ul style="list-style-type: none"> <li>A new address can be registered by touching [New].</li> <li>Select any displayed group to check, edit or delete them.</li> <li>At least one address must be registered for registering a new group.</li> </ul>

**C. E-mail Settings**

- It will not be displayed when the following setting shows that the management device 2 is mounted.  
 [Service Mode] → [Billing Setting] → [Management Function Choice]

**(1) E-mail Subject**

Functions	<ul style="list-style-type: none"> <li>To register the e-mail subject when transmitting the scanned data.</li> </ul>
Use	
Setting/ Procedure	<ul style="list-style-type: none"> <li>A new address can be registered by touching [New].</li> <li>Select any displayed address to detail check, edit or delete the setting.</li> <li>The subject can be set as default by selecting the subject displayed on the screen and pressing [Set as Default].</li> </ul>

**(2) E-mail Body**

Functions	<ul style="list-style-type: none"> <li>To register the e-mail message when transmitting the scanned data.</li> </ul>
Use	
Setting/ Procedure	<ul style="list-style-type: none"> <li>A new address can be registered by touching [New].</li> <li>Select any displayed address to detail check or delete the setting.</li> <li>The text can be set as default by selecting the text displayed on the screen and pressing [Set as Default].</li> </ul>

**8.4.2 Create User Box**

- It will not be displayed when the authentication device is set to “Set” by the following setting.  
[Service Mode] → [Billing Setting] → [Management Function Choice]
- It will not be displayed when the following setting shows that the vendor is mounted.  
[Service Mode] → [Billing Setting] → [Management Function Choice]  
(It will be displayed when the key counter is mounted.)
- This menu is not available due to functional restriction during user authentication when [User Box] is set to Restrict.

**A. Public/Personal User Box**

Functions	<ul style="list-style-type: none"> <li>To register/change the box for storing text data in the hard disk of the machine.</li> </ul>
Use	<ul style="list-style-type: none"> <li>Shared or personal box can be registered according to its intended use.</li> </ul>
Setting/ Procedure	<ul style="list-style-type: none"> <li>A new box can be registered by touching [New].</li> <li>Select any displayed box to change or delete it.</li> </ul>

**B. Bulletin Board User Box**

- It will be displayed only when the optional fax kit (FK-502) is mounted.
- It will not be displayed during user authentication if the fax operation is set to “Restrict” by the function restriction.

Functions	<ul style="list-style-type: none"> <li>To register/change the bulletin board user box.</li> </ul>
Use	
Setting/ Procedure	<ul style="list-style-type: none"> <li>A new box can be registered by touching [New].</li> <li>Select any displayed box to change or delete it.</li> </ul>

**C. Relay User Box**

- It will be displayed only when the optional FAX kit (FK-502) is mounted.
- It will be displayed when the following setting is set to “ON.”  
[Service Mode] → [FAX] → [System] → [Display Setting] → [Relay]

Functions	<ul style="list-style-type: none"> <li>To register/change the Relay User Box.</li> </ul>
Use	
Setting/ Procedure	<ul style="list-style-type: none"> <li>A new box can be registered by touching [New].</li> <li>Select any displayed box to change or delete it.</li> </ul>

### 8.4.3 Limiting Access to Destinations

- It will not be displayed when the following setting is set to “ON.”  
[Administrator Settings] → [Security Settings] → [Enhanced Security Mode]

#### A. Outline

- The Limiting Access to Destinations setting allows or restricts individual user's access to each destination. This enables security control by restricting information that can be accessed.

#### (1) Apply Levels

- One of the six levels from 0 to 5 can be assigned to all destinations. Similarly, one of the levels from 0 to 5 can be assigned to all users. Depending on the combination of the destination and user levels, destinations that a user can access can be limited. For example, users of level 2 can access the destinations that belong to the levels 0 to 2, but cannot access to the destinations that belong to the levels 3 to 5. Level 5 users can access all destinations of the levels 0 to 5.

#### (2) Groups

- A group can be made with a certain name to allow its members to access its destinations. Users and destinations can be registered for the group so that the registered destinations can be accessed by the registered users. Access restriction depending on an individual level is also applied to the group with access to the destinations determined by the combination of the user and destination levels within a group.
- A destination can be included in only one group.
- A user can be included in multiple different groups.

#### B. Apply Levels/Groups to Destinations

##### (1) Address Book

Functions	• Sets a level and a group for destinations registered in the address book.
Use	
Setting/ Procedure	• Select a destination, press [Apply Level] or [Apply Group] and make a setting.

##### (2) Group

Functions	• Sets a level and a group for destinations registered in the group.
Use	
Setting/ Procedure	• Select a destination, press [Apply Level] or [Apply Group] and make a setting.

##### (3) Program

Functions	• Sets a level and a group for destinations registered in the program.
Use	
Setting/ Procedure	• Select a destination, press [Apply Level] or [Apply Group] and make a setting.



**(4) Print Lists**

- It will not be displayed when the following setting shows that authentication device or the vendor is mounted.  
 [Service Mode] → [Billing Setting] → [Management Function Choice]  
 (It will be displayed when the key counter is mounted.)
- It will not be displayed when the authentication device 1 is set to “Set” by the following setting.  
 [Service Mode] → [Billing Setting] → [Management Function Choice]

Functions	<ul style="list-style-type: none"> <li>To set the paper feed tray for output the list for the meter count or the unit check.</li> </ul>
Use	<ul style="list-style-type: none"> <li>It sets the simplex/duplex printing of the output for the sales counter or the unit check list.</li> </ul>
Setting/ Procedure	<Paper tray> <ul style="list-style-type: none"> <li>The default setting is Tray 1.</li> </ul> <Simplex/Duplex> <ul style="list-style-type: none"> <li>The default setting is 1-Sided.</li> </ul>

**D. Auto Color Level Adjust.**

Functions	<ul style="list-style-type: none"> <li>To set the criterion level to discriminate between a colored original and a black-and-white original in the auto color mode.</li> </ul>						
Use	<ul style="list-style-type: none"> <li>To change the criterion level for the partly colored image to be taken as a black-and-white original.</li> </ul>						
Setting/ Procedure	<ul style="list-style-type: none"> <li>Five levels are available to choose from and the default setting is 3.</li> </ul> <table style="margin-left: auto; margin-right: auto;"> <tr> <td style="padding: 0 10px;">Black</td> <td style="padding: 0 10px;">Standard</td> <td style="padding: 0 10px;">Full Color</td> </tr> <tr> <td style="text-align: center;">1</td> <td style="text-align: center;">2 “3”</td> <td style="text-align: center;">4 5</td> </tr> </table>	Black	Standard	Full Color	1	2 “3”	4 5
Black	Standard	Full Color					
1	2 “3”	4 5					

**E. Power Save Settings**

- It will be displayed only when the following setting is set to “Level 1” or “Level 2.”  
 [Administrator Settings] → [Security Setting] → [Administrator Security Level]
- It will not be displayed when the following setting shows that authentication device 1 or the vendor is mounted.  
 [Service Mode] → [Billing Setting] → [Management Function Choice]

**(1) Low Power Mode Settings**

Functions	<ul style="list-style-type: none"> <li>To set the time until low power starts operating after the last key operation has been completed.</li> <li>Low power: To turn LED and LCD OFF, and lower the power consumption.</li> </ul>
Use	<ul style="list-style-type: none"> <li>To change the time until low power starts.</li> </ul>
Setting/ Procedure	<ul style="list-style-type: none"> <li>Use the 10-key pad for setting.</li> <li>The default setting is 15 min.</li> </ul> <p style="text-align: center;">“15 min.” (2 to 240)</p>

**(2) Sleep Mode Settings**

Functions	<ul style="list-style-type: none"> <li>To set the time until sleep mode starts operating after the last key operation has been completed.</li> <li>Turn all lines OFF except 5 V line for control.</li> <li>"OFF" will only be displayed when [No Sleep] in Service Mode is set.</li> </ul>
Use	<ul style="list-style-type: none"> <li>To change the time until the sleep mode starts.</li> </ul>
Setting/ Procedure	<ul style="list-style-type: none"> <li>Use the 10-key pad for setting.</li> <li>The default setting is 20 min.</li> </ul> <p style="text-align: center;">"20 min." (2 to 240) / OFF</p>

**F. Output Settings**

- It will be displayed only when the following setting is set to "Level 2."  
[Administrator Settings] → [Security Settings] → [Administrator Security Levels]
- It will not be displayed when the following setting shows that authentication device or the vendor is mounted.  
[Service Mode] → [Billing Setting] → [Management Function Choice]  
(It will be displayed when the key counter is mounted.)

**(1) Print/Fax Output Settings**

Functions	<ul style="list-style-type: none"> <li>To set the timing for printing for the PC print job or fax received.</li> </ul>
Use	<p>Batch Print : Starts printing when all data are received</p> <p>Page Print : Starts printing every time data for each page are received</p>
Setting/ Procedure	<p>&lt;Printer&gt;</p> <ul style="list-style-type: none"> <li>The default setting is Page Print.</li> </ul> <p>&lt;Fax&gt;</p> <ul style="list-style-type: none"> <li>The default setting is Batch Print.</li> </ul> <p><b>NOTE</b></p> <ul style="list-style-type: none"> <li><b>[FAX] will be displayed only when the optional fax kit (FK-502) is mounted.</b></li> </ul>

**(2) Output Tray Settings**

- ⚠ It will be displayed only when the optional finisher FS-509 or job separator JS-505 is mounted.

<When the FS-519 is mounted>

Functions	<ul style="list-style-type: none"> <li>To set the priority output tray for each application (Copy print, Printer, Fax and Print Reports).</li> </ul>
Use	<ul style="list-style-type: none"> <li>To change the prior output tray according to the application.</li> </ul>
Setting/ Procedure	<ul style="list-style-type: none"> <li>The default settings are as follows.</li> </ul> <p>Copy : Tray 1 (Tray 3: When [Bin Setting] is enabled.)</p> <p>Print : Tray 1</p> <p>Report Output : Tray 2 (Tray 3: When the optional OT-602 is mounted./When [Bin Setting] is enabled.)</p> <p>Fax : Tray 2 (Tray 3: When the optional OT-602 is mounted./When [Bin Setting] is enabled.)</p>

<When the JS-505 is mounted>

Functions	<ul style="list-style-type: none"> <li>To set the priority output tray for each application (Copy print, Printer, Fax and Print Reports).</li> </ul>
Use	<ul style="list-style-type: none"> <li>To change the prior output tray according to the application.</li> </ul>
Setting/ Procedure	<ul style="list-style-type: none"> <li>The default settings are as follows.                      Copy : Tray 1                      Print : Tray 2                      Report Output : Tray 1                      Fax : Tray 2</li> </ul>

**(3) Bin Setting**

- It will be displayed only when the optional mailbin kit MT-502 is mounted.

Functions	<ul style="list-style-type: none"> <li>Assign the tray 1 of the finisher to the mailbin 5, and the tray 2 to the mailbin 6.</li> <li>The tray 2 can be assigned when the optional exit tray OT-602 is mounted.</li> </ul>
Use	<ul style="list-style-type: none"> <li>Use when assigning the tray 1 and the tray 2 of the finisher to the mailbins.</li> </ul>
Setting/ Procedure	<ul style="list-style-type: none"> <li>The default setting is Disable.</li> </ul> <p style="text-align: center;">Enable <span style="float: right;">"Disable"</span></p>

**G. AE Level Adjustment**

- It will be displayed only when the following setting is set to "Level 2."  
 [Administrator Settings] → [Security Settings] → [Administrator Security Levels]
- It will not be displayed when the following setting shows that authentication device or the vendor is mounted.  
 [Service Mode] → [Billing Setting] → [Management Function Choice]  
 (It will be displayed when the key counter is mounted.)

Functions	<ul style="list-style-type: none"> <li>To set the default setting for AE (Auto Exposure) The larger the value becomes the more emphasized the background will be.</li> </ul>
Use	To make the background level foggier: Increase the setting value To make the background level less foggy: Decrease the setting value
Setting/ Procedure	<ul style="list-style-type: none"> <li>The default setting is 2.</li> </ul> <p style="text-align: center;">"2" (0 to 4)</p>

**H. Auto Paper Select for Small Original**

Functions	<ul style="list-style-type: none"> <li>To make the copy setting when the paper is undetectably small, or no original is being set.</li> </ul>
Use	<ul style="list-style-type: none"> <li>To copy the original such as business cards with which the original detection is not effective.                      Copy on Small Size : Copies on A5 paper.                      Copy on A4/Letter : Copies on A4 or Letter (8 1/2 x 11) size paper.                      Prohibit Copy : Does not copy since the original size cannot be detected.                      paper feed tray needs to be selected prior to pressing the Start key.</li> </ul>
Setting/ Procedure	<ul style="list-style-type: none"> <li>The default setting is Prohibit Copy.</li> </ul> <p style="text-align: center;">Copy on Small Size <span style="margin-left: 100px;">Copy on A4/Letter</span> <span style="float: right;">"Prohibit Copy"</span></p>



**I. Blank Page Print Settings**

- It will be displayed only when the following setting is set to “Level 2.”  
[Administrator Settings] → [Security Settings] → [Administrator Security Levels]
- It will not be displayed when the following setting shows that vendor is mounted.  
[Service Mode] → [Billing Setting] → [Management Function Choice]

Functions	• Select whether or not to print the stamp/composition on blank pages.
Use	• To print a stamp/composition on blank pages.
Setting/ Procedure	• The default setting is Do Not Print.  Print “Do Not Print”

**8.5.2 Custom Display Settings**

**A. Copier Settings**

**(1) Default Tab**

Functions	• Selects a default tab display in the copy mode.
Use	• To change the default tab display in the copy mode. Basic : Normal basic screen Quick Copy : This screen displays all options that can be selected for Paper, Zoom, and Duplex/Combine functions. For color functions, all selectable options can be displayed on the screen. The normal [Basic] screen is also displayed as another tab on the screen.
Setting/ Procedure	• The default setting is Basic.  “Basic” Quick Copy

**(2) Shortcut Key 1/2**

Functions	• Selects whether to use the shortcut key.
Use	• Adds frequently used shortcut keys of auxiliary functions to the basic screen.
Setting/ Procedure	• The default setting is OFF.  ON “OFF”  • When this setting is set to ON, select auxiliary functions to get their shortcut keys displayed on the screen.

**B. Scan/Fax Settings**

- It will not be displayed when the following setting shows that authentication device is mounted.  
[Service Mode] → [Billing Setting] → [Management Function Choice]

**(1) Default Tab**

Functions	• To set the basic screen display in scan/fax mode.
Use	• To change the basic screen display in scan/fax mode.
Setting/ Procedure	• The default setting is Address Book.  Address Search (LDAP) Job History “Address Book” Direct Input

**(2) Program Default**

Functions	<ul style="list-style-type: none"> <li>To set the default display for the program screen during scan/fax mode.</li> </ul>
Use	<ul style="list-style-type: none"> <li>To keep the default display on the program screen which frequently changes during scan/fax mode</li> </ul>
Setting/ Procedure	<ul style="list-style-type: none"> <li>The default setting is PAGE 1.  Temporary One-Touch/ "PAGE1" to PAGE27</li> </ul>

**(3) Address Book Index Default**

Functions	<ul style="list-style-type: none"> <li>To set the default display for the address book screen during scan/fax mode.</li> </ul>
Use	<ul style="list-style-type: none"> <li>To keep the default display instead of search string on the address book which frequently changes during scan/fax mode.</li> </ul>
Setting/ Procedure	<ul style="list-style-type: none"> <li>The default setting is Favorite.  "Favorite" /ABC to WXYZ / etc</li> </ul>

**(4) Shortcut Key 1/2**

- [Shortcut Key 2] is not displayed when the optional image controller (IC-409) is installed.

Functions	<ul style="list-style-type: none"> <li>Selects whether to use the shortcut key.</li> </ul>
Use	<ul style="list-style-type: none"> <li>Adds frequently used shortcut keys of auxiliary functions to the basic screen.</li> </ul>
Setting/ Procedure	<ul style="list-style-type: none"> <li>The default setting is OFF.  ON "OFF"</li> <li>When this setting is set to ON, select auxiliary functions to get their shortcut keys displayed on the screen.</li> </ul>

**(5) Default Address Book**

Functions	<ul style="list-style-type: none"> <li>Sets a default screen display for the scan/fax mode where the address book is set to be displayed.</li> </ul>
Use	
Setting/ Procedure	<ul style="list-style-type: none"> <li>The default setting is Index.  "Index" Address Type</li> </ul>

**C. Copy Screen**

- It will not be displayed when the following setting shows that key counter, vendor, or authentication device 1 is mounted.  
 [Service Mode] → [Billing Setting] → [Management Function Choice]  
 However, this menu is available when the key counter is installed and [The next job reservation] is set to License.  
 [Service Mode] → [Billing Setting] → [Management Function Choice]

**(1) Copy Operating Screen**

Functions	<ul style="list-style-type: none"> <li>To set the display on the control panel screen during printing.</li> </ul>
Use	<ul style="list-style-type: none"> <li>To display the screen to indicate printing when printing is being carried out.                      Yes : The screen shows that the printing is being carried out. The job can be reserved with [Program Next Job].                      No: The screen does not indicate the printing being carried out. The normal copy setting screen will be displayed. The copy reservation is available.</li> </ul>
Setting/ Procedure	<ul style="list-style-type: none"> <li>The default setting is No.</li> </ul> <p style="text-align: center;">Yes <span style="margin-left: 150px;">"No"</span></p>

**D. Fax Active Screen**

- It will be displayed only when the optional fax kit (FK-502) is mounted.
- It will not be displayed when the following setting shows that key counter, vendor, or authentication device 1 is mounted.  
 [Service Mode] → [Billing Setting] → [Management Function Choice]

**(1) TX Display**

Functions	<ul style="list-style-type: none"> <li>To set the screen display for the control panel when transmitting fax.</li> </ul>
Use	<ul style="list-style-type: none"> <li>To display [Sending] on the screen when transmitting fax.</li> </ul>
Setting/ Procedure	<ul style="list-style-type: none"> <li>The default setting is No.</li> </ul> <p style="text-align: center;">Yes <span style="margin-left: 150px;">"No"</span></p>

**(2) RX Display**

Functions	<ul style="list-style-type: none"> <li>To set the screen display on the control panel when receiving fax.</li> </ul>
Use	<ul style="list-style-type: none"> <li>To display [Receiving] on the screen when receiving the fax.</li> </ul>
Setting/ Procedure	<ul style="list-style-type: none"> <li>The default setting is No.</li> </ul> <p style="text-align: center;">Yes <span style="margin-left: 150px;">"No"</span></p>

**E. Color Selection Settings**

Functions	<ul style="list-style-type: none"> <li>Specifies a color that highlights a selection on the control panel.</li> </ul>
Use	
Setting/ Procedure	<ul style="list-style-type: none"> <li>The default setting is Green.</li> </ul> <p style="text-align: center;">"Green" <span style="margin-left: 50px;">Blue</span> <span style="margin-left: 50px;">Yellow</span> <span style="margin-left: 50px;">Pumpkin</span></p>

**F. Left Panel Display Default**

Functions	<ul style="list-style-type: none"> <li>Specifies an item that is shown as a default on the left panel display.</li> </ul>		
Use	<ul style="list-style-type: none"> <li>To change the item that is shown as a default on the left panel display.                             <ul style="list-style-type: none"> <li>Job List (List Display) : Displays a list of jobs that are both being printed and waiting to be printed.</li> <li>Job List (Status Display) : Displays the status of jobs that are being processed.</li> <li>Check Job Settings : Displays the setting of the copy job that is being printed.</li> </ul> </li> </ul>		
Setting/ Procedure	<ul style="list-style-type: none"> <li>The default setting is Job List.                             <table style="width: 100%; border: none;"> <tr> <td style="text-align: center;">“Job List.”</td> <td style="text-align: right;">Check Job Settings</td> </tr> </table> </li> </ul>	“Job List.”	Check Job Settings
“Job List.”	Check Job Settings		

**G. Search Option Settings**

**(1) Uppercase and Lowercase Letters**

Functions	<ul style="list-style-type: none"> <li>Select whether or not to differentiate between upper case and lowercase letters.</li> </ul>		
Use			
Setting/ Procedure	<ul style="list-style-type: none"> <li>The default setting is Differentiate.                             <table style="width: 100%; border: none;"> <tr> <td style="text-align: center;">“Differentiate”</td> <td style="text-align: right;">Do Not Differentiate</td> </tr> </table> </li> </ul>	“Differentiate”	Do Not Differentiate
“Differentiate”	Do Not Differentiate		

**(2) Search Option Screen**

Functions	<ul style="list-style-type: none"> <li>Select whether or not to display [Uppercase and Lowercase Letters] setting in the advanced search.</li> <li>Displaying the search option screen allows changing the search criteria for an individual search.</li> </ul>		
Use			
Setting/ Procedure	<ul style="list-style-type: none"> <li>The default setting is OFF.                             <table style="width: 100%; border: none;"> <tr> <td style="text-align: center;">ON</td> <td style="text-align: right;">“OFF”</td> </tr> </table> </li> </ul>	ON	“OFF”
ON	“OFF”		

**8.5.3 Copier Settings**

**A. Auto Booklet ON when Fold & Staple**

- It will be displayed only when the optional saddle stitcher SD-505 is mounted.

Functions	<ul style="list-style-type: none"> <li>To set whether to set the auto booklet when fold &amp; staple is selected.</li> </ul>		
Use	<ul style="list-style-type: none"> <li>To cancel setting the auto booklet when fold &amp; staple is selected.</li> </ul>		
Setting/ Procedure	<ul style="list-style-type: none"> <li>The default setting is Auto Select Booklet.                             <table style="width: 100%; border: none;"> <tr> <td style="text-align: center;">“Auto Select Booklet”</td> <td style="text-align: right;">OFF</td> </tr> </table> </li> </ul>	“Auto Select Booklet”	OFF
“Auto Select Booklet”	OFF		

**B. Auto Zoom for Combine/Booklet**

Functions	<ul style="list-style-type: none"> <li>To set whether to select the appropriate magnification when combine or booklet is selected during auto paper select.</li> </ul>		
Use			
Setting/ Procedure	<ul style="list-style-type: none"> <li>The default setting is Auto Display Zoom Ratio.                             <table style="width: 100%; border: none;"> <tr> <td style="text-align: center;">“Auto Display Zoom Ratio”</td> <td style="text-align: right;">OFF</td> </tr> </table> </li> </ul>	“Auto Display Zoom Ratio”	OFF
“Auto Display Zoom Ratio”	OFF		

**C. Auto Sort/Group Selection**

Functions	<ul style="list-style-type: none"> <li>Selects whether to use the auto sort/group selection function when a job has output of two or more sheets.</li> </ul> <p>Yes : Automatically disables the Auto sort/group selection when a sheet of original is placed on the ADF and the start key is pressed. Automatically enables the Auto sort/group selection when two or more sheets of originals are placed on the ADF and the start key is pressed.</p> <p>No : Disable the Auto sort/group selection.</p>
Use	
Setting/ Procedure	<ul style="list-style-type: none"> <li>The default setting is Yes.</li> </ul> <p style="text-align: center;">"Yes" <span style="float: right;">No</span></p>

**D. Default Copy Settings**

- This menu is unavailable if user authentication is not made while either of authentication devices is set to Set in the [Service Mode] → [Billing Setting] → [Management Function Choice].
- This menu is not available when the key counter is set or when a warning appears to inform that the vendor's main power switch needs to be checked or coins (a card) are not inserted under the condition where the vendor is set to Set in the [Service Mode] → [Billing Setting] → [Management Function Choice].

Functions	<ul style="list-style-type: none"> <li>To make default settings for the copy mode.</li> </ul> <p>* The machine is initialized at the following timings:</p> <ul style="list-style-type: none"> <li>The main power switch is turned ON.</li> <li>Panel is reset.</li> <li>In an Interrupt mode.</li> <li>Auto Reset</li> <li>The password entry screen for account track is changed.</li> </ul>
Use	<ul style="list-style-type: none"> <li>To change the Initial mode setting to meet the user's need.</li> </ul>
Setting/ Procedure	<p>&lt;Current Setting&gt;</p> <ul style="list-style-type: none"> <li>The settings made on the control panel before entering the setting menu screens are registered as the default settings of copy functions.</li> </ul> <p>&lt;Factory Default&gt;</p> <ul style="list-style-type: none"> <li>The settings made at the time of shipment from the factory are registered as the default settings of copy functions.</li> </ul>

### E. Default Enlarge Display Settings

- Displayed only when you select [Utility/Counter] → [User Settings] → [Copier Settings] in the enlarge display mode.

Functions	<ul style="list-style-type: none"> <li>• To make default settings for the enlarge display mode.</li> <li>* The machine is initialized at the following timings:                             <ul style="list-style-type: none"> <li>• The main power switch is turned ON.</li> <li>• Panel is reset.</li> <li>• In an Interrupt mode.</li> <li>• Auto Reset</li> <li>• The password entry screen for account track is changed.</li> </ul> </li> </ul>
Use	<ul style="list-style-type: none"> <li>• To change the Initial mode setting to meet the user's need.</li> </ul>
Setting/ Procedure	<p>&lt;Current Setting&gt;</p> <ul style="list-style-type: none"> <li>• The settings made on the control panel before entering the setting menu screens are registered as the default settings of copy functions.</li> </ul> <p>&lt;Factory Default&gt;</p> <ul style="list-style-type: none"> <li>• The settings made at the time of shipment from the factory are registered as the default settings of copy functions.</li> </ul>

### F. When AMS Direction is Incorrect

- It will not be displayed when the following setting shows that vendor1 is mounted.  
[Service Mode] → [Billing Setting] → [Management Function Choice]

Functions	<ul style="list-style-type: none"> <li>• To set whether to print when the original is set in different direction from the set paper during auto zoom select.</li> </ul>
Use	<ul style="list-style-type: none"> <li>• To display alarm when original is set in different direction from paper and to cancel the job during auto zoom select.                             <ul style="list-style-type: none"> <li>Print : To print according to the selected direction and size of paper</li> <li>Delete Job : To display alarm and cancel the job</li> </ul> </li> </ul>
Setting/ Procedure	<ul style="list-style-type: none"> <li>• The default setting is Print.</li> </ul> <p style="text-align: center;">"Print" <span style="float: right;">Delete Job</span></p>

### G. Separate Scan Output Method

- It will not be displayed when the following setting shows that vendor1 is mounted.  
[Service Mode] → [Billing Setting] → [Management Function Choice]

Functions	<ul style="list-style-type: none"> <li>• To set the output mode at Separate Scan setting.</li> </ul>
Use	<ul style="list-style-type: none"> <li>• To print all at once after reading all data.                             <ul style="list-style-type: none"> <li>Page Print : Print consecutively during the read operation.</li> <li>Batch print : Print all at once after reading all data.</li> <li>Copy setting can be changed after the read operation.</li> </ul> </li> </ul>
Setting/ Procedure	<ul style="list-style-type: none"> <li>• The default setting is Page Print.</li> </ul> <p style="text-align: center;">"Page Print" <span style="float: right;">Batch Print</span></p>

**H. Enlargement Rotation**

- It will not be displayed when the following setting shows that vendor1 is mounted.  
[Service Mode] → [Billing Setting] → [Management Function Choice]

Functions	<ul style="list-style-type: none"> <li>• Sets whether to rotate images of which length is more than 297 mm in the main scan direction (in the horizontal direction on the ADF or the Original glass) in the copying process.</li> </ul> <p style="margin-left: 40px;">Allow : Makes an enlargement rotation only when black is selected for the color setting.</p> <p style="margin-left: 40px;">Restrict : Disables an enlargement rotation regardless of the color setting.</p>
Use	
Setting/ Procedure	<ul style="list-style-type: none"> <li>• The default setting is Restrict.</li> </ul> <p style="text-align: center;">Allow <span style="float: right;">"Restrict"</span></p>

**I. Auto Zoom (Platen)**

- It will be displayed only when the following setting is set to "Level 1" or "Level 2."  
[Administrator Settings] → [Security Settings] → [Administrator Security Levels]

Functions	<ul style="list-style-type: none"> <li>• To set whether to function the auto magnification when the feed tray is selected with document set on the original glass (excepting at automatic paper selection mode.)</li> </ul>
Use	<ul style="list-style-type: none"> <li>• To function the auto magnification when the Tray is selected.</li> </ul>
Setting/ Procedure	<ul style="list-style-type: none"> <li>• The default setting is OFF.</li> </ul> <p style="text-align: center;">ON <span style="float: right;">"OFF"</span></p>

**J. Auto Zoom (ADF)**

- It will be displayed only when the following setting is set to "Level 1" or "Level 2."  
[Administrator Settings] → [Security Settings] → [Administrator Security Levels]

Functions	<ul style="list-style-type: none"> <li>• To set whether to function the auto magnification when the feed tray is selected with document set on the ADF (excepting at automatic paper selection mode.)</li> </ul>
Use	<ul style="list-style-type: none"> <li>• To function the auto magnification when the feed tray is selected.</li> </ul>
Setting/ Procedure	<ul style="list-style-type: none"> <li>• The default setting is ON.</li> </ul> <p style="text-align: center;">"ON" <span style="float: right;">OFF</span></p>

**K. Specify Default Tray when APS Off**

- It will be displayed only when the following setting is set to "Level 1" or "Level 2."  
[Administrator Settings] → [Security Settings] → [Administrator Security Levels]

Functions	<ul style="list-style-type: none"> <li>• To set the tray to be used when APS is cancelled.</li> </ul>
Use	<ul style="list-style-type: none"> <li>• To set the tray for the initial setting when APS is cancelled.</li> </ul>
Setting/ Procedure	<ul style="list-style-type: none"> <li>• The default setting is Tray (Tray 1) Before APS OFF.</li> </ul> <p style="text-align: center;">"Tray Before APS OFF" <span style="float: right;">Default Tray</span></p>

**L. Select Tray for Insert Sheet**

- It will be displayed only when the following setting is set to “Level 1” or “Level 2.”  
[Administrator Settings] → [Security Settings] → [Administrator Security Levels]

Functions	• To select the default setting of the tray for cover sheet paper.
Use	
Setting/ Procedure	• The default setting is Tray 2.

**M. Print Jobs During Copy Operation**

- It will be displayed only when the following setting is set to “Level 2.”  
[Administrator Settings] → [Security Settings] → [Administrator Security Levels]

Functions	• To set whether to accept the printing job for print data or fax data during copy operation.
Use	• To refuse print data or fax data during copy operation. Accept : Receives the print data or fax data to print. Receive Only : Print data or fax data will be printed when the copy operation is finished.
Setting/ Procedure	• The default setting is Accept.  “Accept” <span style="float: right;">Receive Only</span>

**N. Automatic Image Rotation**

- [It will be displayed only when the following setting is set to “Level 1” or “Level 2.”  
[Administrator Settings] → [Security Settings] → [Administrator Security Levels]

Functions	• Sets whether to automatically rotate images to print if the original and specified paper directions are not consistent with each other.
Use	
Setting/ Procedure	• The default setting is ON.  “ON” <span style="float: right;">OFF</span>

**8.5.4 Scan/Fax Settings**

**A. JPEG Compression Level**

Functions	• To set the JPEG compression method when scanning with JPEG while in scan/fax mode.
Use	• To change the compression rate when JPEG scanning. High Quality : Lowers the compression rate and puts priority in quality while scanning. Standard : Compression rate and quality are normally balanced while scanning. High Compression: Makes the compression rate higher and puts priority in lowering the data volume while scanning.
Setting/ Procedure	• The default setting is Standard.  High Quality <span style="margin-left: 100px;">“Standard”</span> <span style="float: right;">High Compression</span>



**B. Black Compression Level**

Functions	<ul style="list-style-type: none"> <li>To set the monochrome compression method for scanning in the monochrome mode while in scan/fax mode.</li> </ul>
Use	<ul style="list-style-type: none"> <li>To be used when changing the monochrome mode while in scanner mode.</li> </ul>
Setting/ Procedure	<ul style="list-style-type: none"> <li>The default setting is MMR.</li> </ul> <p style="text-align: center;">MH <span style="float: right;">“MMR”</span></p>

**C. TWAIN Lock Time**

- It will not be displayed when the optional image controller IC-409 is mounted.

Functions	<ul style="list-style-type: none"> <li>To set the period of time for unlocking the operation panel while in TWAIN scanning.</li> </ul>
Use	
Setting/ Procedure	<ul style="list-style-type: none"> <li>The default setting is 120 sec.</li> </ul> <p style="text-align: center;">“120 sec.” (30 to 300 sec.)</p>

**8.5.5 Default Scan/Fax Settings**

- This menu is unavailable if user authentication is not made while either of authentication devices is set to Set in the [Service Mode] → [Billing Setting] → [Management Function Choice].
- This menu is not available when the key counter is set or when a warning appears to inform that the vendor's main power switch needs to be checked or coins (a card) are not inserted under the condition where the vendor is set to Set in the [Service Mode] → [Billing Setting] → [Management Function Choice].

Functions	<ul style="list-style-type: none"> <li>To make default settings for the fax/scan mode.</li> </ul> <p>* The machine is initialized at the following timings:</p> <ul style="list-style-type: none"> <li>The main power switch is turned ON.</li> <li>Panel is reset.</li> <li>In an Interrupt mode.</li> <li>Auto Reset</li> <li>The password entry screen for account track is changed.</li> </ul>
Use	<ul style="list-style-type: none"> <li>To change the Initial mode setting to meet the user's need.</li> </ul>
Setting/ Procedure	<p>&lt;Current Setting&gt;</p> <ul style="list-style-type: none"> <li>The settings made on the control panel before entering the setting menu screens are registered as the default settings of fax/scan functions.</li> </ul> <p>&lt;Factory Default&gt;</p> <ul style="list-style-type: none"> <li>The settings made at the time of shipment from the factory are registered as the default settings of fax/scan functions.</li> </ul>

### 8.5.6 Default Enlarge Display Settings

- Displayed only when you select [Utility/Counter] → [User Settings] → [Scan/Fax Settings] in the enlarge display mode.

Functions	<ul style="list-style-type: none"> <li>• To make default settings for the enlarge display mode.</li> <li>* The machine is initialized at the following timings:             <ul style="list-style-type: none"> <li>• The main power switch is turned ON.</li> <li>• Panel is reset.</li> <li>• In an Interrupt mode.</li> <li>• Auto Reset</li> <li>• The password entry screen for account track is changed.</li> </ul> </li> </ul>
Use	<ul style="list-style-type: none"> <li>• To change the Initial mode setting to meet the user's need.</li> </ul>
Setting/ Procedure	<p>&lt;Current Setting&gt;</p> <ul style="list-style-type: none"> <li>• The settings made on the control panel before entering the setting menu screens are registered as the default settings of fax/scan functions.</li> </ul> <p>&lt;Factory Default&gt;</p> <ul style="list-style-type: none"> <li>• The settings made at the time of shipment from the factory are registered as the default settings of fax/scan functions.</li> </ul>

### A. Compact PDF Compression Level

Functions	<ul style="list-style-type: none"> <li>• Selects a compression method applied to scanned data that is produced with the use of Compact PDF in the scan/fax mode.</li> </ul>
Use	<ul style="list-style-type: none"> <li>• To change the compression ratio applied to scanned data that is produced with the Compact PDF format.             <ul style="list-style-type: none"> <li>High Quality : Lowers the compression rate and puts priority in quality while scanning.</li> <li>Standard : Compression rate and quality are normally balanced while scanning.</li> <li>High Compression: Makes the compression rate higher and puts priority in lowering the data volume while scanning.</li> </ul> </li> </ul>
Setting/ Procedure	<ul style="list-style-type: none"> <li>• The default setting is Standard.</li> </ul> <p style="text-align: center;">High Quality                      "Standard"                      High Compression</p>

### 8.5.7 Printer Settings

#### A. Basic Settings

##### (1) PDL Setting

Functions	<ul style="list-style-type: none"> <li>• To set the PDL (Page Description Language) for PC printing.</li> </ul>
Use	<ul style="list-style-type: none"> <li>• To fix the PDL as necessary. It usually switches automatically.</li> </ul>
Setting/ Procedure	<ul style="list-style-type: none"> <li>• The default setting is Auto.</li> </ul> <p style="text-align: center;">"Auto"                      PCL                      PS</p>

**(2) Number of Copies**

Functions	<ul style="list-style-type: none"> <li>To set the number to be copied when not specified by the printer driver during PC printing.</li> </ul>
Use	<ul style="list-style-type: none"> <li>To use when the number cannot be specified by the printer driver during printing from Windows DOS, etc.</li> </ul>
Setting/ Procedure	<ul style="list-style-type: none"> <li>The default setting is 1.</li> </ul> <p style="text-align: right;">“1” (1 to 999)</p>

**(3) Original Direction**

Functions	<ul style="list-style-type: none"> <li>To set the default setting for the direction of the original during PC printing.</li> </ul>
Use	
Setting/ Procedure	<ul style="list-style-type: none"> <li>The default setting is Portrait.</li> </ul> <p style="text-align: center;">“Portrait” <span style="float: right;">Landscape</span></p>

**(4) Spool Print Jobs in HDD before RIP**

Functions	<ul style="list-style-type: none"> <li>To set whether to store the print data to HDD when receiving the next job during RIP process of the current job.</li> </ul>
Use	
Setting/ Procedure	<ul style="list-style-type: none"> <li>The default setting is ON</li> </ul> <p style="text-align: center;">“ON” <span style="float: right;">OFF</span></p>

**(5) A4/A3 ↔ LTR/LGR Auto Switch**

Functions	<ul style="list-style-type: none"> <li>To set whether to switch between A4 and Letter (8 1/2 x 11) size paper, and A3 and Ledger (11 x 17) size paper in reading.</li> </ul>
Use	<ul style="list-style-type: none"> <li>To output Letter (8 1/2 x 11) size document to A4 size, and Ledger (11 x 17) size document to A3 size.</li> <li>To output A4 size document to Letter (8 1/2 x 11) size, and A3 size document to Ledger (11 x 17) size.</li> </ul> <p><b>NOTE</b></p> <ul style="list-style-type: none"> <li><b>When switching the size, the image will be printed in the same magnification.</b></li> <li><b>The image will not be reduced when there is image deficiency.</b></li> </ul>
Setting/ Procedure	<ul style="list-style-type: none"> <li>The default setting is OFF.</li> </ul> <p style="text-align: center;">ON <span style="float: right;">“OFF”</span></p>

**(6) Banner Sheet Setting**

Functions	<ul style="list-style-type: none"> <li>To set whether or not to print on the banner (front cover) page.</li> </ul>
Use	<ul style="list-style-type: none"> <li>To use when the banner (front cover) page is to be printed.</li> </ul>
Setting/ Procedure	<ul style="list-style-type: none"> <li>The default setting is OFF.</li> </ul> <p style="text-align: center;">ON <span style="float: right;">“OFF”</span></p>

### (7) Binding Direction Adjustment

Functions	<ul style="list-style-type: none"> <li>Specifies the alignment between the sides of paper (binding position adjustment) in duplex printing.</li> </ul>
Use	<ul style="list-style-type: none"> <li>To achieve faster printing performance, select Productivity Priority. To address mis-alignment problems between sides of copies in the horizontal and vertical directions, select Finishing Priority.                     <ul style="list-style-type: none"> <li>Finishing Priority : Able to optimize sides aligning operation as the process is performed after the machine receives all of the print data.</li> <li>Productivity Priority : Able to accelerate print speed as sides alignment proceeds together with data reception and print operation.</li> <li>Control Adjustments : Comply with the command from the printer driver and does not take the side alignment step.</li> </ul> </li> </ul>
Setting/ Procedure	<ul style="list-style-type: none"> <li>The default setting is Finishing Priority.</li> </ul> <p style="text-align: center;"> <span style="margin-right: 100px;">“Finishing Priority”</span> <span style="margin-right: 100px;">Productivity Priority</span> <span>Control Adjustments</span> </p>

### (8) Line Width Adjustment

- This is displayed only when the function enhanced version 1 firmware is installed.

Functions	<ul style="list-style-type: none"> <li>To correct line width of the output data during PC print.</li> </ul>
Use	<ul style="list-style-type: none"> <li>To correct the line width of the output data according to user's needs.</li> </ul>
Setting/ Procedure	<ul style="list-style-type: none"> <li>The default setting is Thin.</li> </ul> <p style="text-align: center;"> <span style="margin-right: 100px;">“Thin”</span> <span style="margin-right: 100px;">Normal</span> <span>Thick</span> </p>

## B. Paper Setting

### (1) Paper Tray

Functions	<ul style="list-style-type: none"> <li>To set the paper feed tray when not specified by the printer driver during PC printing.</li> </ul>
Use	<ul style="list-style-type: none"> <li>To use when paper feed tray cannot be specified by the printer driver when printing from Windows DOS, etc.</li> </ul>
Setting/ Procedure	<ul style="list-style-type: none"> <li>The default setting is Auto.</li> </ul>

### (2) Paper Size

Functions	<ul style="list-style-type: none"> <li>To set the paper size when not specified by the printer driver during printing.</li> </ul>
Use	<ul style="list-style-type: none"> <li>To use when the paper size cannot be specified by the printer driver during printing from Windows DOS, etc.</li> </ul>

### (3) 2-Sided Print

Functions	<ul style="list-style-type: none"> <li>To set whether to carry out duplex print during PC printing when not specified by the printer driver.</li> </ul>
Use	<ul style="list-style-type: none"> <li>To use when 2-sided printing cannot be specified by the printer driver while printing by Windows DOS, etc.</li> </ul>
Setting/ Procedure	<ul style="list-style-type: none"> <li>The default setting is OFF.</li> </ul> <p style="text-align: center;"> <span style="margin-right: 100px;">ON</span> <span>“OFF”</span> </p>

**(4) Binding Position**

Functions	<ul style="list-style-type: none"> <li>To set the binding direction during duplex printing when not specified by the printer driver during PC printing.</li> </ul>
Use	<ul style="list-style-type: none"> <li>To use when binding direction cannot be specified by the printer driver during printing by Windows DOS, etc.</li> </ul>
Setting/ Procedure	<ul style="list-style-type: none"> <li>The default setting is Left Bind.</li> </ul> <p style="text-align: center;">Top Bind                      “Left Bind”                      Right Bind</p>

**(5) Staple**

- ⚠ The menu is available only when the optional finisher FS-519 or FS-609 is mounted.

Functions	<ul style="list-style-type: none"> <li>To set whether to staple or not when not specified by the printer driver during PC printing.</li> </ul>
Use	<ul style="list-style-type: none"> <li>To use when staple is not specified by the printer driver during printing by the Windows DOS, etc.</li> </ul>
Setting/ Procedure	<ul style="list-style-type: none"> <li>The default setting is OFF.</li> </ul> <p style="text-align: center;">1 Position                      2 Position                      “OFF”</p>

**(6) Punch**

- ⚠ The menu is available only when the optional finisher FS-519/FS-609 and punch kit PK-515/PK-501 is mounted.

Functions	<ul style="list-style-type: none"> <li>To select whether to make punch-holes or not when not specified by the printer driver during PC printing.</li> </ul>
Use	<ul style="list-style-type: none"> <li>To use when the printer driver cannot specify punching during printing from Windows DOS, etc.</li> </ul>
Setting/ Procedure	<ul style="list-style-type: none"> <li>The default setting is OFF.</li> </ul> <p style="text-align: center;">2-Hole/3-Hole/4-Hole                      “OFF”</p> <p>* The number of punch holes being set is available from [Service Mode] → [Finisher].</p>

**(7) Banner Paper Tray**

Functions	<ul style="list-style-type: none"> <li>To set the feed tray for printing on the banner (front cover) page.</li> </ul>
Use	<ul style="list-style-type: none"> <li>To set the feed tray for printing on the banner (front cover) page.</li> </ul>
Setting/ Procedure	<ul style="list-style-type: none"> <li>The default setting is Auto.</li> </ul>

**C. PCL Settings**

**(1) Font Settings**

Functions	<ul style="list-style-type: none"> <li>To set the font when not specified by the printer driver during PC printing.</li> </ul>
Use	<ul style="list-style-type: none"> <li>To use when the printer driver cannot specify the font during printing from Windows DOS, etc.</li> <li>It can be selected from the Resident font or the download font.</li> </ul>
Setting/ Procedure	<ul style="list-style-type: none"> <li>The default setting is Courier.</li> </ul> <p>1. When selecting from the Internal font, touch [Internal], and select the one from the displayed font list.</p>



**(2) ICC Profile Settings**

Functions	<ul style="list-style-type: none"> <li>To select a profile to be used for print jobs from a computer when a profile is not specified by printer driver.</li> </ul>
Use	<ul style="list-style-type: none"> <li>Possible to set a profile separately for each of the following items.                     <ul style="list-style-type: none"> <li>Photo-RGB Color</li> <li>Photo-Output Profile</li> <li>Text-RGB Color</li> <li>Text-Output Profile</li> <li>Figure/Table/Graph-RGB Color</li> <li>Figure/Table/Graph-Output Profile</li> <li>Simulation Profile</li> </ul> </li> </ul>
Setting/ Procedure	<ul style="list-style-type: none"> <li>The default settings are shown below.                     <ul style="list-style-type: none"> <li>Photo-RGB Color : Device Color</li> <li>Photo-Output Profile : Auto</li> <li>Text-RGB Color : Device Color</li> <li>Text-Output Profile : Auto</li> <li>Figure/Table/Graph-RGB Color : Device Color</li> <li>Figure/Table/Graph-Output Profile : Auto</li> <li>Simulation Profile : None</li> </ul> </li> </ul>

**E. XPS Settings**

**(1) Verify XPS Digital Signature**

Functions	<ul style="list-style-type: none"> <li>Selects whether to verify digital signatures attached to XPS (XML Paper Specification) files when printing the files.</li> </ul>
Use	<ul style="list-style-type: none"> <li>When digital signature verification is selected, files with invalid digital signatures are not printed.</li> </ul>
Setting/ Procedure	<ul style="list-style-type: none"> <li>The default setting is OFF.                     <ul style="list-style-type: none"> <li>ON</li> <li>"OFF"</li> </ul> </li> </ul>

**F. Print Reports**

- It will not be displayed when the following setting shows that authentication device 1 or vendor is mounted.  
 [Service Mode] → [Billing Setting] → [Management Function Choice]  
 (It will be displayed when the key counter is mounted.)

Functions	<ul style="list-style-type: none"> <li>To output the report or demo page concerning the print setting.</li> </ul>
Use	<ul style="list-style-type: none"> <li>To check the setting concerning the printer.                      The types of report available for output are as follows.                     <ul style="list-style-type: none"> <li>Configuration Page : The list of printer setting will be output.</li> <li>Demo Page : The test page will be output.</li> <li>PCL Font List : PCL font list will be output.</li> <li>PS Font List : PS font list will be output.</li> </ul> </li> </ul>
Setting/ Procedure	<ol style="list-style-type: none"> <li>Touch [User Setting] → [Printer Setting] → [Print Reports].</li> <li>Select the report to be output.</li> <li>Select the feed tray.</li> <li>Select Simplex or Duplex print, and touch the Start key.</li> </ol>

### 8.5.8 Change Password

- When conducting user authentication (MFP only), it will be displayed only when the authentication is complete.
- This menu is available only when box administrator authentication is established during user authentication or account track.

Functions	<ul style="list-style-type: none"> <li>• To modify the password used for the user authentication.</li> </ul>
Use	<ul style="list-style-type: none"> <li>• To modify the user authentication password currently used.</li> </ul>
Setting/ Procedure	<ul style="list-style-type: none"> <li>• Enter the user authentication password with the keys on the control panel.                     <ul style="list-style-type: none"> <li>Current Password : Enter the user authentication password currently used.</li> <li>New Password : Enter the new user authentication password to be used.</li> <li>Retype Password : Enter the new user authentication password again.</li> </ul> </li> </ul> <p><b>NOTE</b></p> <ul style="list-style-type: none"> <li>• When [Password Rules] which can be displayed by the following setting is set to “ON”, password using the single letter or the password same with the previous one, less than 8-digit will not be modified. [Utility] → [Administrator Settings] → [Security Setting]</li> <li>• When the following setting is set to “ON”, entering the incorrect password three times will cause access lock. When an access lock occurred, turn the main power switch OFF, and wait for 10 seconds or more and turn main power switch ON again. [Administrator Settings] → [Security Setting] → [Enhanced Security Mode]</li> </ul>

### 8.5.9 Change E-mail Address

- When conducting user authentication (MFP only), it will be displayed only when the authentication is complete.
- It will be displayed only when the following setting is set to “Level 2.”  
[Administrator Settings] → [Security Settings] → [Administrator Security Levels]

Functions	<ul style="list-style-type: none"> <li>• To modify the e-mail address which is registered as a user.</li> </ul>
Use	<ul style="list-style-type: none"> <li>• To use when modifying the e-mail address currently being used.</li> </ul>
Setting/ Procedure	<ul style="list-style-type: none"> <li>• Enter the new e-mail address using the keys on the control panel.</li> </ul>





**(4) Enter Power Save Mode**

Functions	<ul style="list-style-type: none"> <li>To set whether to immediately switch to the power save mode after printing in case of receiving the fax during power save mode.</li> </ul>
Use	<ul style="list-style-type: none"> <li>To immediately switch to the power save mode after printing in case of receiving the fax during power save mode.                             <ul style="list-style-type: none"> <li>Normal : Switches to the power save mode according to the normal power save mode after the printing.</li> <li>Immediately : Switches to the power save mode immediately after the printing.</li> </ul> </li> </ul>
Setting/ Procedure	<ul style="list-style-type: none"> <li>The default setting is "Normal."</li> </ul> <p style="text-align: center;">"Normal" <span style="margin-left: 200px;">Immediately</span></p>

**B. Output Settings**

**(1) Print/Fax Output Settings**

Functions	<ul style="list-style-type: none"> <li>To set the timing for printing for the PC print job or fax received.</li> </ul>
Use	<p>Batch Print : Starts printing when all data are received</p> <p>Page Print : Starts printing every time data for each page are received</p>
Setting/ Procedure	<p>&lt;Printer&gt;</p> <ul style="list-style-type: none"> <li>The default setting is Page Print.</li> </ul> <p>&lt;Fax&gt;</p> <ul style="list-style-type: none"> <li>The default setting is Batch Print.</li> </ul> <p><b>NOTE</b></p> <ul style="list-style-type: none"> <li><b>[FAX] will be displayed only when the optional fax kit (FK-502) is mounted.</b></li> </ul>

**(2) Output Tray Settings**

- ▲ It will be displayed only when the optional finisher FS-509 or job separator JS-505 is mounted.

<When the FS-519 is mounted>

Functions	<ul style="list-style-type: none"> <li>To set the priority output tray for each application (Copy print, Printer, Fax and Print Reports).</li> </ul>
Use	<ul style="list-style-type: none"> <li>To change the prior output tray according to the application.</li> </ul>
Setting/ Procedure	<ul style="list-style-type: none"> <li>The default settings are as follows.                             <ul style="list-style-type: none"> <li>Copy : Tray 1 (Tray 3: When [Bin Setting] is enabled.)</li> <li>Print : Tray 1</li> <li>Report Output : Tray 2 (Tray 3: When the optional OT-602 is mounted./When [Bin Setting] is enabled.)</li> <li>Fax : Tray 2 (Tray 3: When the optional OT-602 is mounted./When [Bin Setting] is enabled.)</li> </ul> </li> </ul>

<When the JS-505 is mounted>

Functions	<ul style="list-style-type: none"> <li>To set the priority output tray for each application (Copy print, Printer, Fax and Print Reports).</li> </ul>
Use	<ul style="list-style-type: none"> <li>To change the prior output tray according to the application.</li> </ul>
Setting/ Procedure	<ul style="list-style-type: none"> <li>The default settings are as follows.                             <ul style="list-style-type: none"> <li>Copy : Tray 1</li> <li>Print : Tray 2</li> <li>Report Output : Tray 1</li> <li>Fax : Tray 2</li> </ul> </li> </ul>

**(3) Bin Setting**

- It will be displayed only when the optional mailbin kit MT-502 is mounted.

Functions	<ul style="list-style-type: none"> <li>• Assign the tray 1 of the finisher to the mailbin 5, and the tray 2 to the mailbin 6.</li> <li>• The tray 2 can be assigned when the optional exit tray OT-602 is mounted.</li> </ul>
Use	<ul style="list-style-type: none"> <li>• Use when assigning the tray 1 and the tray 2 of the finisher to the mailbins.</li> </ul>
Setting/ Procedure	<ul style="list-style-type: none"> <li>• The default setting is Disable.</li> </ul> <p style="text-align: center;">Enable <span style="float: right;">"Disable"</span></p>

**(4) Shift Output Each Job**

- It will be displayed only when the optional finisher FS-519/FS-609 or Job separator JS-505 is mounted.

Functions	<ul style="list-style-type: none"> <li>• To set whether to offset each job when paper is printed using the finisher or job separator.</li> </ul>
Use	<ul style="list-style-type: none"> <li>• Some paper type may fail to be discharged or get deteriorated loading when large volume copies are printed using the finisher or job separator. This function is used to print large volume copies when finisher or job separator is mounted. (When this function is set to "No", the paper is discharged without offsetting the paper to the center of the tray.)</li> </ul>
Setting/ Procedure	<ul style="list-style-type: none"> <li>• The default setting is Yes.</li> </ul> <p style="text-align: center;">"Yes" <span style="float: right;">No</span></p>

**C. Date/Time Settings**

Functions	<ul style="list-style-type: none"> <li>• To set the date/time and the time zone to start the clock.</li> </ul>
Use	<ul style="list-style-type: none"> <li>• To change settings concerning the date/time.</li> <li>• This setting should be carried out for set up.</li> </ul>
Setting/ Procedure	<ul style="list-style-type: none"> <li>• For time zone, set the time difference with the world standard time.</li> <li>• Setting range for the time zone: -12:00 to +12:00 (by 30 minutes)</li> <li>• When the following setting is set to "ON", [Set Data] will be displayed. Touch [Set Data] and modify the time. [Administrator Settings] → [Network Settings] → [Detail Settings] → [Time Adjustment Setting]</li> </ul>

**D. Daylight Saving Time**

Functions	<ul style="list-style-type: none"> <li>• To set whether to set the daylight saving time.</li> <li>• To set the time difference in setting the daylight saving time.</li> </ul>
Use	<ul style="list-style-type: none"> <li>• To set the daylight saving time.</li> </ul>
Setting/ Procedure	<ul style="list-style-type: none"> <li>• The default setting is No.</li> </ul> <p style="text-align: center;">Yes <span style="float: right;">"No"</span></p> <ul style="list-style-type: none"> <li>• When setting to ON, set the time difference to move up. "60 min." (1 to 150)</li> </ul>

**E. Weekly Timer Settings**

**(1) Weekly Timer ON/OFF Settings**

Functions	<ul style="list-style-type: none"> <li>To set whether to use or not to use the weekly timer.</li> </ul>
Use	<ul style="list-style-type: none"> <li>To set the weekly timer.</li> </ul>
Setting/ Procedure	<ul style="list-style-type: none"> <li>The default setting is OFF.</li> </ul> <p style="text-align: center;">ON <span style="float: right;">"OFF"</span></p>

**(2) Time Settings**

Functions	<ul style="list-style-type: none"> <li>To set the time to turn ON/OFF the weekly timer for each day of the week.</li> </ul>
Use	
Setting/ Procedure	<ol style="list-style-type: none"> <li>Touch the key of the day to be set.</li> <li>Using the 10-key pad, input the ON time and the OFF time.</li> <li>For cancelling the setting, press [Clear].</li> </ol>

**(3) Date Settings**

Functions	<ul style="list-style-type: none"> <li>To select the date or the day of the week for the weekly timer to function.</li> </ul>
Use	
Setting/ Procedure	<ol style="list-style-type: none"> <li>Select the Year/Month with [+] / [-] keys.</li> <li>For setting by the date, touch the appropriate key of the day.</li> <li>For setting by the day of the week, touch the appropriate key of the week by [Daily Setting].</li> <li>Check to make sure that the set key of the day is highlighted, and touch [OK].</li> </ol>

**(4) Select Time for Power Save**

Functions	<ul style="list-style-type: none"> <li>To set the time to turn power OFF/ON when the weekly timer is set and the power is ON.</li> </ul>
Use	<ul style="list-style-type: none"> <li>To turn power OFF for a certain period of time when the weekly timer is set.</li> </ul>
Setting/ Procedure	<ul style="list-style-type: none"> <li>The default setting is No.</li> </ul> <p style="text-align: center;">Yes <span style="float: right;">"No"</span></p> <p>&lt;Set Time for Power Save&gt;</p> <ul style="list-style-type: none"> <li>Using the 10-key pad, input the time to turn OFF and to turn back ON again.</li> </ul>

**(5) Password for Non-Business Hours**

Functions	<ul style="list-style-type: none"> <li>To set whether to input the password before using when the weekly timer is set.</li> </ul>
Use	<ul style="list-style-type: none"> <li>To set the password for turning the power ON temporarily when the weekly timer is set.</li> </ul>
Setting/ Procedure	<ul style="list-style-type: none"> <li>The default setting is No.</li> </ul> <p style="text-align: center;">Yes <span style="float: right;">"No"</span></p> <ul style="list-style-type: none"> <li>When setting to Yes, enter the password (eight digits).</li> </ul>

**F. Restrict User Access**

**(1) Copy Program Lock Settings**

Functions	• To set the prohibition for modifying the registered copy program.
Use	• To be used when prohibiting the user from changing the copy program.
Setting/ Procedure	1. Touch the key for the appropriate copy program. 2. Touch [OK].

**(2) Delete Saved Copy Program**

Functions	• To delete the registered program job.
Use	• To delete the registered program job.
Setting/ Procedure	1. Touch the appropriate program job. 2. Touch [Delete]. 3. Touch [Yes] on the check screen to delete the program job.

**(3) Restrict Access to Job Settings**

- It will not be displayed when the following setting shows that authentication device 1 or vendor 2 is mounted.

[Service Mode] → [Billing Setting] → [Management Function Choice]

<Changing Job Priority>

Functions	• To set whether to allow or restrict the change on the print priority for the job.
Use	
Setting/ Procedure	• The default setting is Allow.  "Allow" <span style="float: right;">Restrict</span>

<Delete Other User Jobs>

Functions	• To set whether to allow or restrict job delete by other users when the user is authenticated.
Use	
Setting/ Procedure	• The default setting is Restrict.  Allow <span style="float: right;">"Restrict"</span>

<Registering and Changing Addresses>

Functions	• To set whether to allow or restrict the change of the registered address.
Use	
Setting/ Procedure	• The default setting is Allow.  "Allow" <span style="float: right;">Restrict</span>  <b>NOTE</b> • [Allow] cannot be selected when the following setting is set to "ON". [Administrator Settings] → [Security Setting] → [Enhanced Security Mode]

<Changing Zoom Ratio>

Functions	<ul style="list-style-type: none"> <li>To set whether to allow or restrict the change on the registered magnification.</li> </ul>
Use	
Setting/ Procedure	<ul style="list-style-type: none"> <li>The default setting is Allow.</li> </ul> <p style="text-align: center;">"Allow" <span style="float: right;">Restrict</span></p>

<Change the "From" Address>

Functions	<ul style="list-style-type: none"> <li>To set whether or not to prohibit the registered from address to be changed.</li> </ul>
Use	
Setting/ Procedure	<ul style="list-style-type: none"> <li>The default setting is Allow.</li> </ul> <p style="text-align: center;">"Allow" <span style="float: right;">Restrict</span></p>

<Change Registered Overlay>

Functions	<ul style="list-style-type: none"> <li>Selects allow or restrict for the change of registered overlay.</li> </ul>
Use	
Setting/ Procedure	<ul style="list-style-type: none"> <li>The default setting is Allow.</li> </ul> <p style="text-align: center;">"Allow" <span style="float: right;">Restrict</span></p>

**(4) Restrict Operation**

<Restrict Broadcasting>

Functions	<ul style="list-style-type: none"> <li>To set whether or not to prohibit sending the fax to more than one address.</li> </ul>
Use	
Setting/ Procedure	<ul style="list-style-type: none"> <li>The default setting is OFF.</li> </ul> <p style="text-align: center;">ON <span style="float: right;">"OFF"</span></p>

**G. Expert Adjustment**

- It will not be displayed when the following setting shows that vendor 2 is mounted.  
 [Service Mode] → [Billing Setting] → [Management Function Choice]  
 (It will be displayed when the Key Counter is mounted or when the following setting shows that switch No.33 is set to [01] at HEX assignment.  
 [Service Mode] → [System 2] → [Software Switch Setting])

**(1) AE Level Adjustment**

Functions	<ul style="list-style-type: none"> <li>To set the default setting for AE (Auto Exposure) the larger the value becomes the more emphasized the background will be.</li> </ul>
Use	To make the background level foggier: Increase the setting value To make the background level less foggy: Decrease the setting value
Setting/ Procedure	<ul style="list-style-type: none"> <li>The default setting is 2.</li> </ul> <p style="text-align: center;">"2" (0 to 4)</p>

**(2) Printer Adjustment**

<Leading Edge Adjustment>

- It will not be displayed when the following setting shows that Management Device 1 is mounted during the device power is OFF or no authentication is set.  
[Service Mode] → [Billing Setting] → [Management Function Choice]
- This menu is unavailable when the key counter is not inserted while only the key counter is set to Set by [Service Mode] → [Billing Setting] → [Management Function Choice].

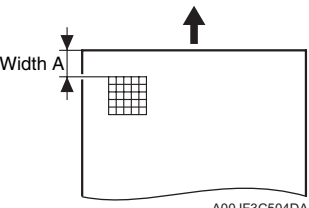
Functions	<ul style="list-style-type: none"> <li>• To vary the print start position in the sub scan direction for each of different paper types in the manual bypass tray.</li> </ul>
Use	<ul style="list-style-type: none"> <li>• The PH unit has been replaced.</li> <li>• The paper type has been changed.</li> <li>• The image on the copy deviates in the sub scan direction.</li> <li>• A faint image occurs on the leading edge of the image.</li> <li>• Able to make an individual adjustment for each paper type of plain paper, thick 1, thick 2, thick 3, thick 4, transparencies, and envelopes.</li> </ul>
Adjustment Specification	<div style="display: flex; align-items: center;">  <div style="margin-left: 20px;"> <p>Width A on the test pattern produced should fall within the following range.</p> <p>Specifications: <math>4.2 \pm 0.5</math> mm Setting range: -3.0 mm to +3.0 mm (in 0.2 mm increments)</p> </div> </div> <p style="text-align: center; font-size: small;">A00JF3C504DA</p>
Adjustment Instructions	<p>If width A is longer than the specifications, make the setting value smaller than the current one.</p> <p>If width A is shorter than the specifications, make the setting value greater than the current one.</p>
Setting/ Procedure	<ol style="list-style-type: none"> <li>1. Place A3 paper on the manual bypass tray.</li> <li>2. Call the Administrator Settings to the screen.</li> <li>3. Touch [System Settings] → [Expert Adjustment] → [Printer Adjustment] → [Leading Edge Adjustment].</li> <li>4. Select the [Normal].</li> <li>5. Press the Start key to let the machine produce a test pattern.</li> <li>6. Check the dimension of width A on the test pattern.</li> <li>7. If width A falls outside the specified range, change the setting using the [+] / [-] key.</li> <li>8. Press the Start key to let the machine produce a test pattern.</li> <li>9. Check the dimension of width A on the test pattern.</li> <li>10. If width A is outside the specified range, change the setting again and make a check again.</li> <li>11. If width A falls within the specified range, touch [OK].</li> <li>12. Following the same procedure, adjust for thick 1 to 3, OHP, and envelope.</li> </ol>

bizhub C353/C253/C203

Adjustment / Setting

<Centering>

- It will not be displayed when the following setting shows that Management Device 1 is mounted during the device power is OFF or no authentication is set.  
[Service Mode] → [Billing Setting] → [Management Function Choice]
- This menu is unavailable when the key counter is not inserted while only the key counter is set to Set by [Service Mode] → [Billing Setting] → [Management Function Choice].

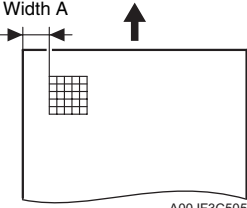
Functions	<ul style="list-style-type: none"> <li>• To vary the print start position in the main scan direction for each paper source.</li> </ul>
Use	<ul style="list-style-type: none"> <li>• The PH unit has been replaced.</li> <li>• A paper feed unit has been added.</li> <li>• The image on the copy deviates in the main scan direction.</li> </ul>
Adjustment Specification	<div style="display: flex; align-items: center;">  <div style="margin-left: 20px;"> <p>Width A on the test pattern produced should fall within the following range.</p> <p>Specifications: 3.0 ± 0.5 mm Setting range: -3.0 mm to +3.0 mm (in 0.2 mm increments)</p> </div> </div>
Adjustment Instructions	<p>If width A is longer than the specifications, make the setting value smaller than the current one.</p> <p>If width A is shorter than the specifications, make the setting value greater than the current one.</p>
Setting/ Procedure	<ol style="list-style-type: none"> <li>1. Call the Administrator Settings to the screen.</li> <li>2. Touch [System Settings] → [Expert Adjustment] → [Printer Adjustment] → [Centering].</li> <li>3. Select the paper source to be adjusted.</li> <li>4. Press the Start key to let the machine produce a test pattern.</li> <li>5. Check the dimension of width A on the test pattern.</li> <li>6. If width A falls outside the specified range, change the setting using the [+] / [-] key.</li> <li>7. Press the Start key to let the machine produce a test pattern.</li> <li>8. Check the dimension of width A on the test pattern.</li> <li>9. If width A is outside the specified range, change the setting again and make a check again.</li> <li>10. If width A falls within the specified range, touch [OK].</li> <li>11. Following the same procedure, adjust for all other paper sources. (Use A4 or 8 1/2 × 11 plain paper for the bypass.)</li> </ol>



<Leading Edge Adjustment (Duplex Side 2)>

- It will not be displayed when the following setting shows that Management Device 1 is mounted during the device power is OFF or no authentication is set.  
[Service Mode] → [Billing Setting] → [Management Function Choice]
- This menu is unavailable when the key counter is not inserted while only the key counter is set to Set by [Service Mode] → [Billing Setting] → [Management Function Choice].

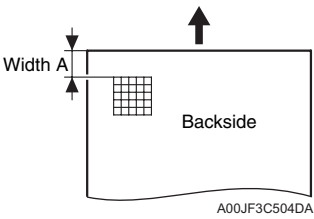
Functions	<ul style="list-style-type: none"> <li>• Makes an adjustment by changing the image write start position in the sub scan direction on the 2nd side of duplex printing for individual types of paper.</li> </ul>
Use	<ul style="list-style-type: none"> <li>• When the 2nd side image on paper fed from the tray is shifted in the sub scan direction.</li> <li>• Able to make an individual adjustment for each paper type of plain paper, thick 1, thick 2 and thick 3.</li> </ul>
Adjustment Specification	 <p>Width A on the test pattern produced should fall within the following range.</p> <p>Specifications: <math>4.2 \pm 0.5</math> mm Setting range: -3.0 mm to +3.0 mm (in 0.2 mm increments)</p>
Adjustment Instructions	<p>If width A is longer than the specifications, make the setting value smaller than the current one.</p> <p>If width A is shorter than the specifications, make the setting value greater than the current one.</p>
Setting/ Procedure	<ol style="list-style-type: none"> <li>1. Call the Administrator Settings to the screen.</li> <li>2. Touch [System Settings] → [Expert Adjustment] → [Printer Adjustment] → [Leading Edge Adjustment (Duplex side 2)].</li> <li>3. Select the [Normal].</li> <li>4. Press the Start key to let the machine produce a test pattern.</li> <li>5. Check the dimension of width A on the test pattern.</li> <li>6. If width A falls outside the specified range, change the setting using the [+] / [-] key.</li> <li>7. Press the Start key to let the machine produce a test pattern.</li> <li>8. Check the dimension of width A on the test pattern.</li> <li>9. If width A is outside the specified range, change the setting again and make a check again.</li> <li>10. If width A falls within the specified range, touch [OK].</li> <li>11. Following the same procedure, adjust for thick 1 to 3, OHP, and envelope.</li> </ol>

bizhub C353/C253/C203

Adjustment / Setting

<Centering (Duplex 2nd Side)>

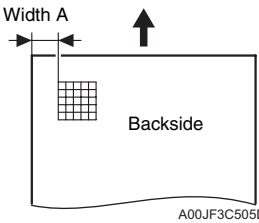
Functions	<ul style="list-style-type: none"> <li>To vary the print start position in the main scan direction for each paper source in the 2-sided mode.</li> </ul>
Use	<ul style="list-style-type: none"> <li>To use when the optional automatic duplex unit AD-503 is set up.</li> <li>The image on the backside of the 2-sided copy deviates in the main scan direction.</li> </ul>
Adjustment Specification	<div style="display: flex; align-items: center;">  <div style="margin-left: 20px;"> <ul style="list-style-type: none"> <li>Width A on the test pattern produced should fall within the following range.</li> <li>For measurement, use the image produced on the backside of the test pattern.</li> </ul> <p>Specifications: 3.0 ± 0.5 mm                      Setting range: -3.0 mm to +3.0 mm                      (in 0.2 mm increments)</p> </div> </div>
Adjustment Instructions	<ul style="list-style-type: none"> <li>If width A is longer than the specifications, make the setting value smaller than the current one.</li> <li>If width A is shorter than the specifications, make the setting value greater than the current one.</li> </ul>
Setting/ Procedure	<ol style="list-style-type: none"> <li>Call the Administrator Settings to the screen.</li> <li>Touch [System Settings] → [Expert Adjustment] → [Printer Adjustment] → [Centering (Duplex 2nd Side)].</li> <li>Select the paper source to be adjusted.</li> <li>Press the Start key to let the machine produce a test pattern.</li> <li>Check the dimension of width A on the test pattern.</li> <li>If width A falls outside the specified range, change the setting using the [+] / [-] key.</li> <li>Press the Start key to let the machine produce a test pattern.</li> <li>Check the dimension of width A on the test pattern on the backside of the copy.</li> <li>If width A is outside the specified range, change the setting again and make a check again.</li> <li>If width A falls within the specified range, touch [OK].</li> <li>Following the same procedure, adjust for all other paper sources.                      (Use A4 or 8 1/2 × 11 plain paper for the manual bypass tray.)</li> </ol>

<Erase Leading Edge>

- It will be displayed only when the following setting is set to "Level 2".  
 [Service Mode] → [Enhanced Security] → [Administrator Feature Level]

Functions	<ul style="list-style-type: none"> <li>To set the leading edge erase amount of the paper.</li> </ul>
Use	<ul style="list-style-type: none"> <li>To change the width of the area not printed along the leading edge of the paper.</li> </ul>
Setting/ Procedure	<ul style="list-style-type: none"> <li>The default setting is 4 mm.</li> </ul> <div style="display: flex; justify-content: space-around; margin-top: 10px;"> <span>"4 mm"</span> <span>5 mm</span> <span>7 mm</span> </div>

bizhub\_C353/C253/C203

Adjustment / Setting

<Vertical Adjustment>

- It will be displayed only when the following setting is set to "Level 2."  
 [Service Mode] → [Enhanced Security] → [Administrator Feature Level]

Functions	<ul style="list-style-type: none"> <li>To synchronize the paper transport speed with the image writing speed.</li> </ul>
Use	<ul style="list-style-type: none"> <li>The I adjustment becomes necessary.</li> <li>The printed image on the copy distorts (stretched, shrunk).</li> <li>When the printed image on the copy is stretched in the sub scan direction.</li> <li>Able to make an individual adjustment for each paper type of plain paper, thick 1, thick 2, thick 3 and thick 4.</li> </ul>
Adjustment Specification	<div style="display: flex; align-items: center;"> <div style="flex: 1;"> <p style="text-align: center;">A00JF3C506DA</p> </div> <div style="flex: 1; padding-left: 20px;"> <p>Width A and width B on the test pattern produced should fall within the following ranges.                      Width A: equivalent to one grid                      Width B: equivalent to 48 grids</p> <p>Specifications                      A: 7.9 to 8.3                      B: 389.1 to 392.1</p> <p>Setting Range                      A, B: -7 to +7</p> </div> </div>
Adjustment Instructions	<p>If width A or B is longer than the specifications, make the setting value smaller than the current one.</p> <p>If width A or B is shorter than the specifications, make the setting value greater than the current one.</p>
Adjustment Procedure	<ol style="list-style-type: none"> <li>Load manual bypass tray with A3 or 11 × 17 plain paper.</li> <li>Call the Administrator Settings to the screen.</li> <li>Touch these keys in this order: [System Settings] → [Expert Adjustment] → [Vertical Adjustment].</li> <li>Press the Start key to let the machine produce a test pattern.</li> <li>Check width A (equivalent to one grid) and width B (equivalent to 48 grids) on the test pattern.</li> <li>If width of A or B falls outside the specified range, change the setting using the [+]/[-] keys.</li> <li>Press the Start key to let the machine produce a test pattern again.</li> <li>Check width A and width B on the test pattern.</li> <li>If width A or B falls outside the specified range, change the setting value and make a check again.</li> <li>If width A or B falls within the specified range, touch [OK].</li> <li>Following the same procedure, adjust for [Thick 1 to 3], [OHP], and [Envelope]. (Check width A only for [OHP] and [Envelope].)</li> </ol>

bizhub C353/C253/C203

Adjustment / Setting

 <Media Adjustment>

Functions	<ul style="list-style-type: none"> <li>Adjust the 2nd image transfer output (ATVC) on the 1st page and the 2nd page for each paper type.</li> <li>This function is provided to open [Transfer Output Fine Adjustment] → [2nd Transfer Adjust] of Service Mode up to administrator and the fine-adjusted value is reflected in the Service Mode setting.</li> </ul>
Use	<ul style="list-style-type: none"> <li>To use when the transfer failure at the trailing edge occurs.</li> </ul>
Adjustment Specification	"0" (-8 to +7)
Adjustment Instructions	<p>To increase the ATVC value (in the direction of a foggier image): increase the setting value in + direction.</p> <p>To decrease the ATVC value (in the direction of a less foggy image): increase the setting value in - direction.</p>
Setting/ Procedure	<ol style="list-style-type: none"> <li>Call the Administrator Setting to the screen.</li> <li>Touch these keys in this order: [Expert Adjustment] → [Printer Adjustment] → [Media Adjustment].</li> <li>Select the side of the image (Front side or Back side), on which the transfer failure at the trailing edge occurs.</li> </ol> <p><b>NOTE</b></p> <ul style="list-style-type: none"> <li><b>Only 1st side can be selected for Envelope and Transparency.</b></li> </ul> <ol style="list-style-type: none"> <li>Select the paper type with the transfer failure at the trailing edge.</li> <li>Enter the new setting from the [+] / [-].</li> <li>Touch [OK] to validate the adjustment value.</li> <li>Check the copy image for any image problem.</li> </ol>

**(3) Finisher Adjustment**

[See P.28 of the SD-505 service manual.](#)

 [See P.62 of the FS-519/PK-515/OT-602 service manual.](#)

[See P.37 of the FS-609/PK-501 service manual.](#)

**(4) Density Adjustment**

<Thick Paper Image Density-Yellow, Magenta, Cyan, Black>

Functions	<ul style="list-style-type: none"> <li>To fine-adjust density of printed images of each color for thick paper and OHP transparencies. (Only black color adjustable for OHP transparencies)</li> </ul>
Use	<ul style="list-style-type: none"> <li>To change the density of the printed image for each color with thick paper and OHP transparencies</li> </ul>
Adjustment Range	Lighter (5 steps), "Std", Darker (5 steps)
Adjustment Instructions	Light color: Touch the Darker key. Dark color: Touch the Lighter key.
Adjustment Procedure	<ol style="list-style-type: none"> <li>Call the Administrator Settings to the screen.</li> <li>Touch [System Settings] → [Expert Adjustment] → [Density Adjustment].</li> <li>Select a type of thick paper and a color that need to be adjusted.</li> <li>Touch the Lighter or Darker key to correct the image density.</li> </ol>

<Black Image Density>

Functions	<ul style="list-style-type: none"> <li>To fine-adjust the density of the printed image for a black copy</li> </ul>
Use	<ul style="list-style-type: none"> <li>To vary the density of the printed image of a black copy</li> </ul>
Adjustment Range	Lighter (2 steps), "Std", Darker (2 steps)
Adjustment Instructions	If the black is light, touch the Darker key. If the black is dark, touch the Lighter key.
Setting/ Procedure	<ol style="list-style-type: none"> <li>Call the Administrator Settings to the screen.</li> <li>Touch [System Settings] → [Expert Adjustment] → [Density Adjustment] → [Black Image Density].</li> <li>Touch the Lighter or Darker key as necessary to correct the image density.</li> </ol>

**(5) Image Stabilization**

<Image Stabilization Only>

Functions	<ul style="list-style-type: none"> <li>The image stabilization sequence is carried out without clearing the historical data of image stabilization control.</li> </ul>
Use	<ul style="list-style-type: none"> <li>Use if an image problem persists even after [Gradation Adjustment] has been executed.</li> <li>When [D Max Density] and [Background Voltage Margin] of Service Mode are changed.</li> </ul>
Setting/ Procedure	<ol style="list-style-type: none"> <li>Call the Administrator Settings to the screen.</li> <li>Touch [System Settings] → [Expert Adjustment] → [Image Stabilization] → [Image Stabilization Only].</li> <li>Press the Start key to start Stabilizer. The Start key turns red and stays lit up red during the Stabilizer sequence.</li> <li>Stabilizer is completed when the Start key turns blue.</li> </ol>

<Initialize+Image Stabilization>

Functions	<ul style="list-style-type: none"> <li>To carry out an image stabilization sequence after the historical data of image stabilization control has been initialized.</li> </ul>
Use	<ul style="list-style-type: none"> <li>Use if an image problem persists even after [Gradation Adjustment] has been executed.</li> <li>Use if tone reproduction and maximum density are faulty even after image stabilization has been executed.</li> </ul>
Setting/ Procedure	<ol style="list-style-type: none"> <li>Call the Administrator Settings to the screen.</li> <li>Touch [System Settings] → [Expert Adjustment] → [Image Stabilization] → [Initialize+Image Stabilization].</li> <li>Press the Start key to start Stabilizer. The Start key turns red and stays lit up red during the Stabilizer sequence.</li> <li>Stabilizer is completed when the Start key turns blue.</li> </ol>

bizhub C353/C253/C203

Adjustment / Setting

**(6) Color Registration Adjust**

- It will not be displayed when the following setting shows that Management Device 1 is mounted during the device power is OFF or no authentication is set.  
[Service Mode] → [Billing Setting] → [Management Function Choice]
  - This menu is unavailable when the key counter is not inserted while only the key counter is set to Set by [Service Mode] → [Billing Setting] → [Management Function Choice].
- <Color Registration Adjust (Yellow, Magenta, Cyan)>

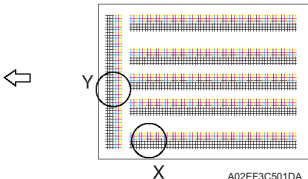
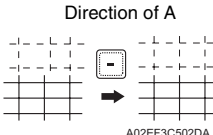
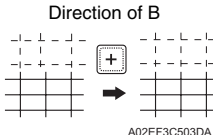
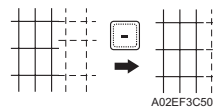
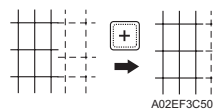
Functions	<ul style="list-style-type: none"> <li>To adjust color shift if there is any when comparing the original with copy of the plain or thick paper.</li> </ul>
Use	<ul style="list-style-type: none"> <li>To correct any color shift.</li> <li>Able to make an individual adjustment for each paper type of plain paper, thick 1, thick 2, thick 3 and thick 4.</li> </ul>
Adjustment Range	"0" (-6 to +6 dot)
Adjustment Instructions	<p>If the cross deviates in the direction of A, increase the setting. If the cross deviates in the direction of B, decrease the setting.</p>
Setting/ Procedure	<ol style="list-style-type: none"> <li>Call the Administrator Settings to the screen.</li> <li>Touch [System Settings] → [Expert Adjustment] → [Color Registration Adjust].</li> <li>Load tray 1 with A3/11x17 or A4/8 1/2 x11 normal paper.</li> <li>Press the Start key.</li> <li>On the test pattern produced, check for deviation between the black line and the line of each color at positions X and Y.</li> <li>Select the color to be adjusted.</li> <li>Using the [+]/[-] key, change the setting value as necessary. (At this time, only the line of the selected color moves.)</li> <li>Produce another test pattern and make sure that there is no deviation.</li> </ol> <p>Check Procedure Check point X, Y</p> <div style="text-align: right;">  </div> <p><b>Adjustment for X direction: Check point X</b></p> <div style="display: flex; justify-content: space-around;"> <div style="text-align: center;"> <p>Direction of A</p>  </div> <div style="text-align: center;"> <p>Direction of B</p>  </div> </div> <p><b>Adjustment for Y direction: Check point Y</b></p> <div style="display: flex; justify-content: space-around;"> <div style="text-align: center;"> <p>Direction of A</p>  </div> <div style="text-align: center;"> <p>Direction of B</p>  </div> </div>

bizhub\_C353/C253/C203

Adjustment / Setting

**(7) Gradation Adjustment**

- It will not be displayed when the following setting is set to “ON.”  
[Service Mode] → [Imaging Process Adjustment] → [Dev. Bias Choice]
- It will not be displayed when the following setting shows that Management Device 1 is mounted during the device power is OFF or no authentication is set.  
[Service Mode] → [Billing Setting] → [Management Function Choice]
- This menu is unavailable when the key counter is not inserted while only the key counter is set to Set by [Service Mode] → [Billing Setting] → [Management Function Choice].

Functions	<ul style="list-style-type: none"> <li>• To make an automatic adjustment of gradation based on the test pattern produced and the readings taken by the scanner.</li> </ul>
Use	<ul style="list-style-type: none"> <li>• Color reproduction performance becomes poor.</li> <li>• The IU has been replaced.</li> <li>• The image transfer belt unit has been replaced.</li>   <li>• Printer (Gradation) : It gives the highest priority to gradation performance of the image as it adjusts.</li> <li>• Printer (Resolution) : It gives the highest priority to reproduction performance of letters and lines as it adjusts.</li> <li>• Copy : It gives the highest priority to increasing the number of images to be stored in the memory as it adjusts.</li> </ul>
Adjustment Procedure	<p>1. Touch [Stabilizer] and the Start key to perform image stabilization.</p> <p><b>NOTE</b></p> <ul style="list-style-type: none"> <li>• <b>Before executing gradation adjust, be sure to perform Stabilizer.</b></li> </ul> <p>2. Call the Administrator Settings to the screen.</p> <p>3. Touch [System Settings] → [Expert Adjustment] → [Gradation Adjustment].</p> <p>4. Select the appropriate mode for the gradation adjustment.</p> <p>5. Press the Start key to let the machine produce a test pattern.</p> <p>6. Place the test pattern produced on the original glass.</p> <p>7. Place ten blank sheets of A3/11 x 17 paper on the test pattern and lower the original cover.</p> <p>8. Press the Start key. (The machine will then start scanning the test pattern.)</p> <p>9. Touch [OK] and repeat steps from 2 through 7 twice (a total of three times).</p> <ul style="list-style-type: none"> <li>• If the image is faulty, perform the troubleshooting procedures for image problems.</li> </ul>

bizhub\_C353/C253/C203

Adjustment / Setting



**(8) Scanner Area**

- Use the following color chart for the adjustment of the scanner section.
- If the color chart is not available, a scale may be used instead.
- It will be displayed only when the following setting is set to “Level 2.”  
[Service Mode] → [Enhanced Security] → [Administrator Feature Level]
- It will not be displayed when the following setting shows that Management Device 1 is mounted during the device power is OFF or no authentication is set.  
[Service Mode] → [Billing Setting] → [Management Function Choice]
- This menu is unavailable when the key counter is not inserted while only the key counter is set to Set by [Service Mode] → [Billing Setting] → [Management Function Choice].

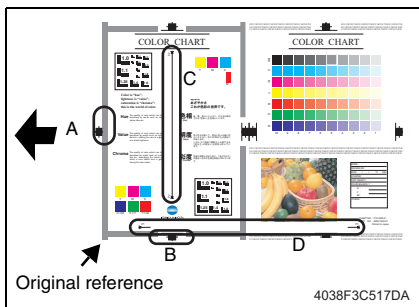

- A: Scanner Adjustment: Leading Edge Adjustment
- B: Scanner Adjustment: Centering
- C: Horizontal Adjustment
- D: Vertical Adjustment

<Scanner Adjustment: Leading Edge>

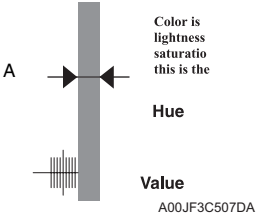
Functions	<ul style="list-style-type: none"> <li>To adjust variations in mounting accuracy and sensitivity of the scanner home sensor and in mounting accuracy of the original width scale by varying the scan start position in the main scan direction.</li> </ul>
Use	<p>When the original glass is replaced. When the original width scale is replaced.</p>
Adjustment Specification	<div style="display: flex; align-items: center;"> <div style="flex: 1;">  </div> <div style="flex: 2;"> <ul style="list-style-type: none"> <li>A width on the color chart and one on the copy sample are measured and adjusted so that the difference of A width satisfies the specifications shown below.</li> <li>An adjustment must have been completed correctly of [Leading Edge Adjustment] of the Printer Adjustment.</li> </ul> <p><b>Specifications</b> A: ± 0.5 mm</p> <p><b>Setting range</b> -5.0 to +5.0 (in 0.1 mm increments)</p> </div> </div>
Adjustment Instructions	<p>If the copy image is less than the specified length, increase the setting value. If the copy image exceeds the specified length, decrease the setting value.</p>
Setting/ Procedure	<ol style="list-style-type: none"> <li>Call the Administrator Settings to the screen.</li> <li>Touch [System Settings] → [Expert Adjustment] → [Scanner Adjustment] → [Scanner Adjustment: Leading Edge].</li> <li>Position the color chart correctly so that the original reference point is aligned with the scale.</li> <li>Press the Start key to make a copy.</li> <li>Check point A on the image of the copy.</li> <li>If the image falls outside the specified range, change the setting using the [+]/ [-] key.</li> <li>Press the Start key to make another copy.</li> <li>Check the image on the copy to see if the specifications are met.</li> <li>Make adjustments until the specifications are met.</li> </ol>

bizhub C353/C253/C203

Adjustment / Setting

<Scanner Adjustment: Centering>

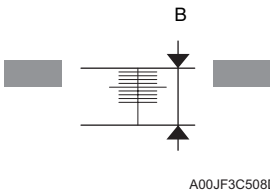
Functions	<ul style="list-style-type: none"> <li>To adjust part-to-part variations in accuracy of IR parts and their mounting accuracy by varying the scan start position in the main scan direction.</li> </ul>
Use	<ul style="list-style-type: none"> <li>When the CCD unit is replaced.</li> <li>When the original glass is replaced.</li> <li>The scanner home sensor has been replaced.</li> </ul>
Adjustment Specification	<div style="display: flex; align-items: center; justify-content: center;">  <div style="margin-left: 20px;"> <ul style="list-style-type: none"> <li>B width on the color chart and one on the copy sample are measured and adjusted so that the difference of B width satisfies the specifications shown below.</li> <li>An adjustment must have been completed correctly of [Leading Edge Adjustment] of the Printer Adjustment.</li> </ul> <p>Specifications B: ± 1.0 mm</p> <p>Setting range -10.0 to +10.0 (in 0.1 mm increments)</p> </div> </div>
Adjustment Instructions	<p>If the copy image is less than the specified length, increase the setting value. If the copy image exceeds the specified length, decrease the setting value.</p>
Setting/ Procedure	<ol style="list-style-type: none"> <li>Call the Administrator Setting to the screen.</li> <li>Touch [System Settings] → [Expert Adjustment] → [Scanner Adjustment] → [Scanner Adjustment: Centering].</li> <li>Position the color chart correctly so that the original reference point is aligned with the scale.</li> <li>Press the Start key to make a copy.</li> <li>Check point B on the image of the copy.</li> <li>If the image falls outside the specified range, change the setting using the [+] / [-] key.</li> <li>Press the Start key to make a copy.</li> <li>Check point B of the image on the copy to see if the specifications are met.</li> <li>Make adjustments until the specifications are met.</li> </ol>

bizhub C353/C253/C203

Adjustment / Setting

<Horizontal Adjustment>

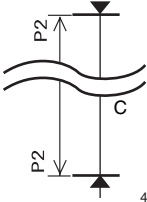
Functions	<ul style="list-style-type: none"> <li>To adjust the zoom ratio in the main scan direction for the scanner section.</li> </ul>
Use	<ul style="list-style-type: none"> <li>The CCD unit has been replaced.</li> </ul>
Adjustment Specification	<div style="display: flex; align-items: center;">  <div style="margin-left: 20px;"> <p>•Measure C width on the color chart and on the sample copy, and adjust the gap to be within the following specification.</p> <p>Specifications C: ± 1.0 mm</p> <p>Setting range 0.990 to 1.010 (in 0.001 increments)</p> </div> </div> <p style="text-align: center; font-size: small;">4038F3C516DA</p>
Adjustment Instructions	<p>If the C width on the copy sample is less than one on color chart, increase the setting. If the C width on the copy sample exceeds one on color chart, decrease the setting.</p>
Setting/ Procedure	<ol style="list-style-type: none"> <li>1. Call the Administrator Settings to the screen.</li> <li>2. Touch [System Settings] → [Expert Adjustment] → [Scanner Adjustment] → [Horizontal Adjustment].</li> <li>3. Position the color chart correctly so that the original reference point is aligned with the scale.</li> <li>4. Press the Start key to make a copy.</li> <li>5. Check the C width on the image of the copy.</li> <li>6. If the image falls outside the specified range, change the setting using the [+] / [-] key.</li> <li>7. Press the Start key to make another copy.</li> <li>8. Check the image on the copy to see if the specifications are met.</li> <li>9. Make adjustments until the specifications are met.</li> </ol>

<Vertical Adjustment>

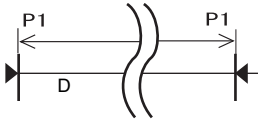
Functions	<ul style="list-style-type: none"> <li>To adjust the zoom ratio in the sub scan direction for the scanner section</li> </ul>
Use	<ul style="list-style-type: none"> <li>The scanner assy has been replaced.</li> <li>The scanner motor has been replaced.</li> <li>The scanner drive cables have been replaced.</li> </ul>
Adjustment Specification	<div style="display: flex; align-items: center;">  <div style="margin-left: 20px;"> <p>•Measure D width on the color chart and on the sample copy, and adjust the gap to be within the following specification.</p> <p>Specifications D: ± 1.5 mm</p> <p>Setting Range 0.990 to 1.010 (in 0.001 increments)</p> </div> </div> <p style="text-align: center; font-size: small;">4038F3C518DA</p>
Adjustment Instructions	<p>If the D width on the copy sample is less than one on color chart, increase the setting. If the D width on the copy sample exceeds one on color chart, decrease the setting.</p>
Setting/ Procedure	<ol style="list-style-type: none"> <li>Call the Administrator Settings to the screen.</li> <li>Touch [System Settings] → [Expert Adjustment] → [Scanner Adjustment] → [Vertical Adjustment].</li> <li>Position the color chart correctly so that the original reference point is aligned with the scale.</li> <li>Press the Start key to make a copy.</li> <li>Check the D width on the image of the copy.</li> <li>If the image falls outside the specified range, change the setting using the [+] / [-] key.</li> <li>Press the Start key to make another copy.</li> <li>Check the image on the copy to see if the specifications are met.</li> <li>Make adjustments until the specifications are met.</li> </ol>

**(9) ADF Adjustment**

- It will be displayed only when the following setting is set to "Level 2."  
[Service Mode] → [Enhanced Security] → [Administrator Feature Level]  
[See P.28 of the DF-611 service manual.](#)

**(10) Line Detection**

<Prior Detection Setting>

Functions	<ul style="list-style-type: none"> <li>To set whether or not to perform pre-detection of stain on the ADF original glass.</li> <li>To set the detection level of the pre-detection of stain on the ADF original glass.</li> <li>To set how to display the warning when stain on the ADF original glass is detected.</li> </ul>									
Use	<ul style="list-style-type: none"> <li>Use when changing the display of the warning which requests the cleaning of the stain on the glass detected by the pre-detection of the lines.                     <ul style="list-style-type: none"> <li>TYPE1 : Warning will be displayed by the maintenance mark. (warning code: D-1/D-2)</li> <li>TYPE2 : Warning will be displayed on the message area on the basic screen.</li> <li>TYPE3 : Warning will be displayed on all screens.</li> <li>OFF : Warning will not be displayed.</li> </ul> </li> <li>Use when changing the detection level for the pre-detection of stain on the original glass.                     <ul style="list-style-type: none"> <li>Low : Stain on the glass will not be detected easily.</li> <li>Normal : Normal detection level</li> <li>High : Stain on the glass will easily be detected.</li> </ul> </li> </ul>									
Setting/ Procedure	<ul style="list-style-type: none"> <li>The default setting is Yes.                     <table style="width: 100%; border: none;"> <tr> <td style="text-align: center;">"Yes"</td> <td style="text-align: center;">No</td> </tr> </table> </li> </ul> <p><b>NOTE</b></p> <ul style="list-style-type: none"> <li><b>[Warning Level] and [Detection Level] can be set when "Yes" is selected.</b></li> <li><b>Be aware that selecting "No" and performing the pre-detection with the following setting will display "NG."</b></li> <li><b>[Service Mode] → [Machine] → [Split Line Prior Detection]</b></li> <li><b>When "No" is selected, the original glass cleaning operation after the job ends does not operate.</b></li> </ul> <p>&lt;Warning Level&gt;</p> <ul style="list-style-type: none"> <li>The default setting is TYPE2.</li> </ul> <table style="width: 100%; border: none;"> <tr> <td style="text-align: center;">TYPE1</td> <td style="text-align: center;">"TYPE2"</td> <td style="text-align: center;">TYPE3</td> <td style="text-align: center;">OFF</td> </tr> </table> <p>&lt;Detection Level&gt;</p> <ul style="list-style-type: none"> <li>The default setting is Std.</li> </ul> <table style="width: 100%; border: none;"> <tr> <td style="text-align: center;">Low</td> <td style="text-align: center;">"Std."</td> <td style="text-align: center;">High</td> </tr> </table>	"Yes"	No	TYPE1	"TYPE2"	TYPE3	OFF	Low	"Std."	High
"Yes"	No									
TYPE1	"TYPE2"	TYPE3	OFF							
Low	"Std."	High								

<Detection While Feeding Setting>

Functions	<ul style="list-style-type: none"> <li>To set the operation for detection and removing operation of stain on the ADF original glass when feeding the original.</li> </ul>
Use	<ul style="list-style-type: none"> <li>Use when changing the operation for detection and removing operation of stain on the ADF original glass when feeding the original.                             <ul style="list-style-type: none"> <li>0 : The glass will stop moving when the original is fed, and will not perform removing the stain.</li> <li>1 : The glass will move between originals when feeding the original.</li> <li>2 : When the original is fed, the glass will move while reading the original in order to remove the stain, and reduce the lines.</li> <li>3 to 6 : When the original is fed, the glass will move while reading the original in order to remove the stain. The lines will be reduced also by the image process control. The level 3, 4, 5, and 6 of the image process are set in this order with 3 being the most efficient in reducing the lines.</li> </ul> </li> </ul> <p><b>NOTE</b></p> <ul style="list-style-type: none"> <li><b>When this function is used, an image quality problem might be occurred in the side effect by the image processing control according to the dirt condition of the original glass.</b></li> <li>When the following setting is set to "0" or "1", the range which the administrator can set will be restricted to "0 (Disable)" or "1 (Enable)." [Service mode] → [System 2] → [Split Line Detect. Setting] → [Paper Passaging Detection]</li> </ul>
Setting/ Procedure	<ul style="list-style-type: none"> <li>The default setting is 1.</li> </ul> <p style="text-align: right;">0 to 6</p>

**H. List/Counter**

**(1) Management List**

- It will not be displayed when the following setting shows that vendor is mounted.  
[Service Mode] → [Billing Setting] → [Management Function Choice]  
(It will be displayed when the Key counter is mounted or when the following setting shows that switch No.33 is set to [01] at HEX assignment.  
[Service Mode] → [System 2] → [Software Switch Setting])

<Job Settings List>

Functions	<ul style="list-style-type: none"> <li>To output the value set by the setting menu.</li> </ul>
Use	
Setting/ Procedure	<ol style="list-style-type: none"> <li>Touch [Job Settings List].</li> <li>Select the feed tray.</li> <li>Select simplex or duplex print, and touch the Start key.</li> </ol>

**(2) Paper Size/Type Counter**

Functions	<ul style="list-style-type: none"> <li>To register the combination of the specific paper size and the paper type, and to set the count.</li> </ul>
Use	
Setting/ Procedure	<ol style="list-style-type: none"> <li>Press a key out of 1 to 10 registration keys.</li> <li>Select the paper type.</li> <li>Touch the paper size key to select the paper size.</li> </ol>

### (3) Meter Counter List

- Setting will be available only when the following setting shows that either authentication device, management device 2, vendor 2 is mounted.  
[Service Mode] → [Billing Setting] → [Management Function Choice]

Functions	<ul style="list-style-type: none"> <li>To output the meter counter list.</li> </ul>
Use	<ul style="list-style-type: none"> <li>To print out the list in this setting because counter list cannot be printed when the following setting shows that vendor is mounted. [Meter Counter] → [Details]</li> </ul>
Setting/ Procedure	<ol style="list-style-type: none"> <li>1. Touch [Meter Counter List].</li> <li>2. Select the Feed tray.</li> <li>3. Select Simplex or Duplex print, and touch the Start key.</li> </ol>

### (4) Check Consumables List

- Setting will be available only when the following setting shows that either authentication device, management device 2, vendor 2 is mounted.  
[Service Mode] → [Billing Setting] → [Management Function Choice]

Functions	<ul style="list-style-type: none"> <li>To output the consumable life list.</li> </ul>
Use	<ul style="list-style-type: none"> <li>To print out the list in this setting because the list cannot be printed when the following setting shows that Vendor is mounted. [Utility] → [Check Consumable Life]</li> </ul>
Setting/ Procedure	<ol style="list-style-type: none"> <li>1. Touch [Consumable Life List].</li> <li>2. Select the Feed tray.</li> <li>3. Select Simplex or Duplex print, and touch the Start key.</li> </ol>

## I. Reset Settings

### (1) System Auto Reset

Functions	<ul style="list-style-type: none"> <li>To set the period of time until system auto reset starts functioning.</li> </ul>		
Use	<ul style="list-style-type: none"> <li>To change the period of time until system auto reset starts functioning.</li> </ul>		
Setting/ Procedure	<p>&lt;Priority Mode&gt;</p> <ul style="list-style-type: none"> <li>To set the functions displayed during system auto reset from Copy and Scan/Fax.</li> <li>The default setting is Copy.</li> </ul> <table style="width: 100%; text-align: center;"> <tr> <td style="border: none;">“Copy”</td> <td style="border: none;">Scan/Fax</td> </tr> </table> <p>&lt;System Auto Reset Time&gt;</p> <ul style="list-style-type: none"> <li>The default setting is 1 min.</li> </ul> <p style="text-align: center;">“1 min.” (1 to 9, OFF)</p>	“Copy”	Scan/Fax
“Copy”	Scan/Fax		

### (2) Auto Reset

Functions	<ul style="list-style-type: none"> <li>To set the period of time until auto reset starts functioning in “Copy” and “Scan/Fax.”</li> </ul>
Use	<ul style="list-style-type: none"> <li>To change the period of time until auto reset starts functioning.</li> </ul>
Setting/ Procedure	<ul style="list-style-type: none"> <li>The default setting is 1 min.</li> </ul> <p style="text-align: center;">“1 min.” (1 to 9, No)</p>



**(3) Job Reset**

<When Account is changed>

- It will not be displayed when the following setting shows that authentication device is mounted.

[Service Mode] → [Billing Setting] → [Management Function Choice]

(It will be displayed when the key counter is mounted.)

Functions	• Selects whether to reset (initialize) a machine when the key counter is unplugged, a magnetic card is pulled out, or user authentication/account track is set.
Use	• To select not to reset to the default settings even when the accounts are changed through the use of a data management device.
Setting/ Procedure	• The default setting is Reset.  "Reset" <span style="float: right;">Do Not Reset</span>

<When Original is set on ADF>

Functions	• Select whether to reset the function when originals are placed on the ADF.
Use	• Reset the function when originals are set on the ADF.
Setting/ Procedure	• The default setting is Do Not Reset.  Reset <span style="float: right;">"Do Not Reset"</span>

<Next Job: Staple Setting>

Functions	• To set whether to cancel the staple setting when the staple setting job started and the next job setting has become available.
Use	
Setting/ Procedure	• The default setting is OFF.  ON <span style="float: right;">"OFF"</span>

<Next Job: Original Set/Bind Direction>

Functions	• To set whether to cancel the original set/bind direction when the job (which original set/bind direction is set) started and the next job setting has become available.
Use	
Setting/ Procedure	• The default setting is OFF.  ON <span style="float: right;">"OFF"</span>

<Next Job: Reset Data After Job>

Functions	• To set whether to cancel the setting for scanning or transmitting fax when the scanning is finished or fax is transmitted, making the next job setting available. (The address will be cleared even when [OFF] is selected.)
Use	
Setting/ Procedure	• The default setting is ON.  "ON" <span style="float: right;">OFF</span>

**J. User Box Settings**

**(1) Delete Unused User Box**

Functions	• To delete the unnecessary box without data.
Use	
Setting/ Procedure	1. Touch [Delete Unused User Box]. 2. Touch [Yes] on the Check screen.

**(2) Delete Secure Print Documents**

Functions	• To delete the whole classified documents in the box.
Use	
Setting/ Procedure	1. Touch [Delete Secure Documents]. 2. Touch [Yes] on the Check screen.

**(3) Auto Delete Secure Document**

Functions	• To set whether or not to delete the confidential documents in the box after a certain period of time. It also sets the period of time to store data.
Use	
Setting/ Procedure	• The default setting is 1 Day.  12 Hours "1 Day" 2 Days 3 Days 7 Days 30 Days Save

**(4) Encrypted PDF Delete Time**

Functions	• Specifies whether to delete encrypted PDF data stored in the box after a lapse of a predetermined period of time. Sets the time period for which encrypted PDF data can be stored.
Use	
Setting/ Procedure	• The default setting is 1 Day.  12 Hours "1 Day" 2 Days 3 Days 7 Days 30 Days Save

**(5) Touch & Print Delete Time**

Functions	• Specifies whether to delete touch & print data stored in the box after a lapse of a predetermined period of time. Sets the time period for which touch & print data can be stored
Use	
Setting/ Procedure	• The default setting is 1 Day.  12 Hours "1 Day" 2 Days 3 Days 7 Days 30 Days Save

**(6) Document Hold Setting**

Functions	• Selects whether to store the document again in the box after it was retrieved from the box. • If the function is set to No, the document is automatically deleted after it was retrieved.
Use	
Setting/ Procedure	• The default setting is OFF.  ON "OFF"

**(7) External Memory Function Settings**

Functions	<ul style="list-style-type: none"> <li>This operation enables or disables functions using an external memory connected to this machine.</li> <li>Capability to enable [Save Document] and [Print Document] separately.</li> </ul>
Use	<p>Save Document : a function that saves scanned documents into the external memory using [Save Document] in the box mode.</p> <p>Print Document : a function that prints and sends documents saved in the external memory using [Use Document] in the box mode.</p>
Setting/ Procedure	<p>&lt;Save Document&gt;</p> <ul style="list-style-type: none"> <li>The default setting is OFF.</li> </ul> <p style="text-align: center;">ON <span style="float: right;">"OFF"</span></p> <p>&lt;Print Document&gt;</p> <ul style="list-style-type: none"> <li>The default setting is ON.</li> </ul> <p style="text-align: center;">"ON" <span style="float: right;">OFF</span></p>

**K. Standard Size Setting**

- It will be displayed only when the following setting is set to "Level 2."  
[Service Mode] → [Enhanced Security] → [Administrator Feature Level]

**(1) Original Glass Original Size Detect**

Functions	<ul style="list-style-type: none"> <li>To change the document size detection table.</li> </ul>
Use	<ul style="list-style-type: none"> <li>Use to change the setting for the document size detection table.</li> </ul>
Setting/ Procedure	<ul style="list-style-type: none"> <li>The default setting is Table1.</li> </ul> <p style="text-align: center;">"Table1" <span style="float: right;">Table2</span></p>

**(2) Foolscap Size Setting**

Functions	<ul style="list-style-type: none"> <li>To set the size for foolscap paper.</li> </ul>
Use	<ul style="list-style-type: none"> <li>Upon setup.</li> <li>To change the size for foolscap paper.</li> </ul>
Setting/ Procedure	<ul style="list-style-type: none"> <li>Select the size from among the following five.</li> </ul> <p style="text-align: center;">220 x 330 mm    8½ x 13    8¼ x 13    8⅞ x 13¼    "8 x 13"</p>

**L. Stamp Settings**

**(1) Header/Footer Settings**

Functions	<ul style="list-style-type: none"> <li>Saves or deletes header/footer settings.</li> </ul>
Use	<ul style="list-style-type: none"> <li>Able to obtain registered header/footer data by [Application] → [Stamp/Composition]</li> </ul>
Setting/ Procedure	<ul style="list-style-type: none"> <li>Touch [New] to register new headers and footers.</li> </ul>

**(2) Fax TX Settings**

Functions	<ul style="list-style-type: none"> <li>Specifies whether to reset a stamp setting when fax is sent.</li> </ul>
Use	
Setting/ Procedure	<ul style="list-style-type: none"> <li>The default setting is Cancel.</li> </ul> <p style="text-align: center;">"Cancel" <span style="float: right;">Do Not Cancel</span></p>

**M. Blank Page Print Settings**

Functions	<ul style="list-style-type: none"> <li>Specifies whether to print a stamp/page number on blank pages.</li> </ul>
Use	
Setting/ Procedure	<ul style="list-style-type: none"> <li>The default setting is Print.</li> </ul> <p style="text-align: center;">"Print" <span style="float: right;">Do Not Print</span></p>

**N. Application Key Settings**

- This is displayed only when the function enhanced version 2 or later firmware is installed.
- This is displayed only when the optional i-Option (LK-101 or LK-103) is activated.

Functions	<ul style="list-style-type: none"> <li>To assign the additional functions provided by i-Option to the application keys.</li> </ul>
Use	<ul style="list-style-type: none"> <li>This settings allow free application key assignment to additional functions provided by i-Option as well as to "User Box", "Fax/Scan" and "Copy" to which the application keys were conventionally assigned. (However, Key 0 is assigned to the function of displaying the application menu so that other functions cannot be assigned to Key 0.)</li> <li>The functions that can be assigned are as follows: Copy, Fax/Scan, User Box, Image Panel, Web Browser, My Panel</li> </ul>
Setting/ Procedure	<ol style="list-style-type: none"> <li>Select [Key 1] or [Key 2].</li> <li>Select a function to which the key is assigned, and touch [OK].</li> </ol>

**8.6.2 Administrator/Machine Settings**

**A. Administrator Registration**

Functions	<ul style="list-style-type: none"> <li>Registers administrator information displayed Help service/Administrator information screen as well as sender addresses used for E-mail transmission from the machine.</li> </ul>
Use	
Setting/ Procedure	<ol style="list-style-type: none"> <li>Touch [Administrator Name], [E-mail Address] to input them.</li> <li>Using the 10-key pad, enter the extension No.</li> </ol>

**B. Input Machine Address**

Functions	<ul style="list-style-type: none"> <li>To register the name of the machine and e-mail address.</li> </ul>
Use	<p style="text-align: center;">Machine Name : When the file name of the transmitted file or the document name of document registered in Box is generated automatically, it is added.</p> <p style="text-align: center;">E-mail : To be used as from address at internal Fax transmission.</p>
Setting/ Procedure	<ol style="list-style-type: none"> <li>Touch [Device Name] and input the name.</li> <li>Touch [E-mail Address] and input the E-mail address.</li> </ol>

### 8.6.3 One-Touch/User Box Registration

#### A. Create One-Touch Destination

##### (1) Address Book

<E-mail>

Functions	<ul style="list-style-type: none"> <li>To register/change the e-mail address for transmitting the scanned data by e-mail.</li> </ul>
Use	
Setting/ Procedure	<ul style="list-style-type: none"> <li>Touch [New] to register the new address.</li> <li>Select any displayed address to check, edit, or delete the setting.</li> </ul>

<User Box>

- It will not be displayed when the following setting shows that authentication device or the vendor is mounted.

[Service Mode] → [Billing Setting] → [Management Function Choice]

(It will be displayed when the key counter is mounted.)

Functions	<ul style="list-style-type: none"> <li>To register or change the box address for storing the scanned data to the box in the hard disk of the machine.</li> </ul>
Use	
Setting/ Procedure	<ul style="list-style-type: none"> <li>Touch [New] to register the new address.</li> <li>Select any displayed address to check, edit, or delete the setting.</li> <li>At least one user box must be registered in order to register the box address.</li> </ul>

<Fax>

Functions	<ul style="list-style-type: none"> <li>To register or change the fax number for transmitting the fax.</li> </ul>
Use	
Setting/ Procedure	<ul style="list-style-type: none"> <li>Touch [New] to register the new address.</li> <li>Select any displayed address to check, edit, or delete the setting.</li> </ul>

<PC (SMB)>

Functions	<ul style="list-style-type: none"> <li>To register or change the SMB address for transmitting the scanned data by SMB.</li> </ul>
Use	
Setting/ Procedure	<ul style="list-style-type: none"> <li>Touch [New] to register the new address.</li> <li>Select any displayed address to check, edit, or delete the setting.</li> </ul>

<FTP>

Functions	<ul style="list-style-type: none"> <li>To register and change the FTP address for transmitting the scanned data by FTP.</li> </ul>
Use	
Setting/ Procedure	<ul style="list-style-type: none"> <li>Touch [New] to register the new address.</li> <li>Select any displayed address to check, edit, or delete the setting.</li> </ul>

<WebDAV>

Functions	<ul style="list-style-type: none"> <li>To register and change the WebDAV address for transmitting the scanned data by FTP.</li> </ul>
Use	
Setting/ Procedure	<ul style="list-style-type: none"> <li>Touch [New] to register the new address.</li> <li>Select any displayed address to check, edit, or delete the setting.</li> </ul>

<IP Address Fax>

- Setting will be available only when [IP Address FAX] is set to “ON” in the following settings.  
 [Administrator Settings] → [Network Settings] → [Network Fax Settings] → [Network Fax Function Settings]

Functions	<ul style="list-style-type: none"> <li>• To register/change the IP address fax destination when transmitting the IP address fax data.</li> </ul>
Use	
Setting/ Procedure	<ul style="list-style-type: none"> <li>• A new address can be registered by touching [New].</li> <li>• Select any displayed address to check, change or delete the setting.</li> </ul>

<Internet Fax>

- Setting will be available only when [Internet FAX] is set to “ON” in the following settings.  
 [Administrator Settings] → [Network Settings] → [Network Fax Settings] → [Network Fax Function Settings]

Functions	<ul style="list-style-type: none"> <li>• To register/change the Internet fax address when transmitting the internet fax data.</li> </ul>
Use	
Setting/ Procedure	<ul style="list-style-type: none"> <li>• A new address can be registered by touching [New].</li> <li>• Select any displayed address to check, change or delete the setting.</li> </ul>

**(2) Group**

Functions	<ul style="list-style-type: none"> <li>• To register or change the group with a number of addresses to transmit data simultaneously.</li> </ul>
Use	
Setting/ Procedure	<ul style="list-style-type: none"> <li>• Touch [New] to register the new group.</li> <li>• elect any displayed group to check, edit, or delete the setting.</li> <li>• At least one address must be registered in order to register the group.</li> </ul>

**(3) E-mail Settings**

- It will not be displayed when the management device 2 is set to “Set” by the following setting.  
 [Service Mode] → [Billing Setting] → [Management Function Choice]

<E-mail Subject>

Functions	<ul style="list-style-type: none"> <li>• To register the e-mail subject for transmitting the scanned data by e-mail.</li> </ul>
Use	
Setting/ Procedure	<ul style="list-style-type: none"> <li>• Touch [New] to register the new subject.</li> <li>• Select any displayed subject to detail check, edit, or delete the setting.</li> <li>• The subject can be set as default by selecting the subject displayed on the screen and pressing [Set as Default].</li> </ul>

<E-mail Body>

Functions	<ul style="list-style-type: none"> <li>• To register the e-mail message for transmitting the scanned data by e-mail.</li> </ul>
Use	
Setting/ Procedure	<ul style="list-style-type: none"> <li>• Touch [New] to register the new message.</li> <li>• Select any displayed message to detail check or delete the setting.</li> <li>• The text can be set as default by selecting the text displayed on the screen and pressing [Set as Default].</li> </ul>

**B. Create User Box**

- It will not be displayed when the following setting shows that authentication device 1 is mounted.  
[Service Mode] → [Billing Setting] → [Management Function Choice]
- It will not be displayed when the following setting shows that vendor is mounted.  
[Service Mode] → [Billing Setting] → [Management Function Choice]  
(It will be displayed when the key counter is mounted.)

**(1) Public/Personal User Box**

Functions	• To register or change the box for storing the text data in the hard disk of the machine.
Use	• To register the shared or personal box for any purpose.
Setting/ Procedure	• Touch [New] to register the new box. • Select any displayed box to edit or delete it.

**(2) Bulletin Board User Box**

Functions	• To register or change the bulletin board user box.
Use	
Setting/ Procedure	• Touch [New] to register the new box. • Select any displayed box to edit or delete it.

**(3) Relay User Box**

- It will be displayed when the following setting is set to “ON.”  
[Service Mode] → [FAX] → [System] → [Display Setting] → [Relay]

Functions	• To register/change the Relay User Box.
Use	
Setting/ Procedure	• A new box can be registered by touching [New]. • Select any displayed box to change or delete it.

**(4) Annotation User Box**

Functions	• To register or change the annotation user box.
Use	• To attach the image of the date, time, and/or filing number to the document data stored in the scanner mode, and to distribute them.
Setting/ Procedure	• Touch [New] key to register the new box. • Select any displayed box to change or delete it.

**C. One-Touch/User Box Registration List**

- It will not be displayed when the following setting shows that vendor is mounted.  
 [Service Mode] → [Billing Setting] → [Management Function Choice]  
 (It will be displayed when the Key counter is mounted or when the following setting shows that switch No.33 is set to [01] at HEX assignment.  
 [Service Mode] → [System 2] → [Software Switch Setting])

**(1) Address Book List**

Functions	• To output the address book list.
Use	• To print the list of abbreviated addresses which are registered.
Setting/ Procedure	<ol style="list-style-type: none"> <li>1. Select the destination type to be output.</li> <li>2. Touch [Starting destination No.] and enter the number from which output starts.</li> <li>3. Touch [No. of Destinations] and specify the number of destinations to be output.</li> <li>4. Touch [Print], and select the paper feed tray.</li> <li>5. Select the simplex or duplex print, and press the Start key to output the list of abbreviated addresses.</li> </ol>

**(2) Group List**

Functions	• To output the group list.
Use	• To print out the list of addresses of the group which are registered.
Setting/ Procedure	<ol style="list-style-type: none"> <li>1. Touch [Starting destination No.] and enter the number from which output starts.</li> <li>2. Touch [No. of Destinations] and specify the number of destinations to be output.</li> <li>3. Touch [Print], and select the paper feed tray.</li> <li>4. Select the simplex or duplex print, and press the Start key to output the list of abbreviated addresses.</li> </ol>

**(3) Program List**

Functions	• To output the program list.
Use	• To print out the list of the program addresses which are registered.
Setting/ Procedure	<ol style="list-style-type: none"> <li>1. Select the destination type to be output.</li> <li>2. Touch [Starting destination No.] and enter the number from which output starts.</li> <li>3. Touch [No. of Destinations] and specify the number of destinations to be output.</li> <li>4. Touch [Print], and select the paper feed tray.</li> <li>5. Select the simplex or duplex print, and press the Start key to output the list of abbreviated addresses.</li> </ol>

**(4) E-mail Subject/Text List**

Functions	• To output the subject or the text list.
Use	• To print out the e-mail subject/text List which are registered.
Setting/ Procedure	<ol style="list-style-type: none"> <li>1. Select the paper feed tray.</li> <li>2. Select the simplex or duplex print, and press the Start key to output the list of abbreviated addresses.</li> </ol>



**D. Maximum Number of User Boxes**

Functions	<ul style="list-style-type: none"> <li>Set the maximum of public, personal, and group boxes that individual users can hold.</li> </ul>
Use	
Setting/ Procedure	<ol style="list-style-type: none"> <li>Select a user box type and name.</li> <li>If a maximum number of user boxes is not specified, set Max. No. of Use Boxes to [OFF].</li> <li>If a maximum number of user boxes is not specified, set Max. No. of Use Boxes to [OFF].</li> </ol>

**8.6.4 User Authentication/Account Track**

- It will not be displayed when the following setting shows that key counter or vendor is mounted.  
[Service Mode] → [Billing Setting] → [Management Function Choice]

**A. General Settings**

**(1) User Authentication**

Functions	<ul style="list-style-type: none"> <li>To set the user authentication method.</li> </ul>
Use	<ul style="list-style-type: none"> <li>To select whether to authenticate the user by the external server or MFP.</li> </ul>
Setting/ Procedure	<ul style="list-style-type: none"> <li>The default setting is OFF.</li> </ul> <p style="text-align: center;">                 “OFF”                      ON (External Server)                      ON (MFP)             </p> <p><b>NOTE</b></p> <ul style="list-style-type: none"> <li>[OFF] cannot be selected when the following setting is set to “ON.” [Administrator Settings] → [Security Setting] → [Enhanced Security Mode]</li> <li>[ON (External Server)] cannot be selected when external servers are not registered in the following setting. [Administrator Settings] → [User Authentication/Account Track] → [External Server Settings]</li> <li>Neither [ON (External Server)] or [ON (MFP)] can be selected when the presence of management device is set in the following setting. [Service Mode] → [Billing Setting] → [Management Function Choice]</li> </ul>

**(2) Public User Access**

Functions	<ul style="list-style-type: none"> <li>To set whether to allow or prohibit the nonregistered user to use the system when User authentication has been set.</li> <li>Able to use the machine without authentication by logging in as a public user when [ON (Without Login)] is selected.</li> </ul>
Use	
Setting/ Procedure	<ul style="list-style-type: none"> <li>The default setting is Restrict.</li> </ul> <p style="text-align: center;">                 “Restrict”                      Allow                      ON (Without Login)             </p> <p><b>NOTE</b></p> <ul style="list-style-type: none"> <li>This setting is not available without user authentication.</li> <li>[Allow] cannot be selected when the following setting is set to “ON.” [Administrator Settings] → [Security Setting] → [Enhanced Security Mode]</li> <li>[Allow] cannot be selected when [Synchronize User Authentication &amp; Account Track] is set to “Do Not Synchronize.”</li> </ul>

bizhub C353/C253/C203

Adjustment / Setting

**(3) Account Track**

Functions	<ul style="list-style-type: none"> <li>To set whether to enable the account track function or not.</li> </ul>
Use	<ul style="list-style-type: none"> <li>To enable the account track function.</li> </ul>
Setting/ Procedure	<ul style="list-style-type: none"> <li>The default setting is OFF.</li> </ul> <p style="text-align: center;">"OFF" <span style="float: right;">ON</span></p>

**(4) Account Track Input Method**

Functions	<ul style="list-style-type: none"> <li>To set the authentication method for the account track.</li> </ul>
Use	<ul style="list-style-type: none"> <li>To select whether to authenticate by password or by account name &amp; password.</li> </ul>
Setting/ Procedure	<ul style="list-style-type: none"> <li>The default setting is Account Name &amp; Password.</li> </ul> <p style="text-align: center;">"Account Name &amp; Password" <span style="float: right;">Password Only</span></p> <p><b>NOTE</b></p> <ul style="list-style-type: none"> <li><b>This setting is not available without the account track.</b></li> <li><b>"Password Only" cannot be set when using both user authentication and account track.</b></li> </ul>

**(5) Synchronize User Authentication & Account Track**

Functions	<ul style="list-style-type: none"> <li>To set whether to synchronize the user authentication and account track.</li> </ul>
Use	<ul style="list-style-type: none"> <li>To be used when not to synchronize the user authentication and account track.</li> </ul>
Setting/ Procedure	<ul style="list-style-type: none"> <li>The default setting is Synchronize.</li> </ul> <p style="text-align: center;">"Synchronize" <span style="float: right;">Do not synchronize</span></p> <p><b>NOTE</b></p> <ul style="list-style-type: none"> <li><b>The setting is available only when carrying out the user authentication and account track.</b></li> </ul>

**(6) When # of Jobs Reach Maximum**

Functions	<ul style="list-style-type: none"> <li>To set whether to stop the currently printing job and start the next job, or to stop the machine, when reaching to the upper limit for the number of printed pages set by the user authentication and the account track.</li> </ul>
Use	<ul style="list-style-type: none"> <li>To stop the machine when the number of printed pages reach the upper limit set by the user authentication and the account track.</li> </ul>
Setting/ Procedure	<ul style="list-style-type: none"> <li>The default setting is Skip Job.</li> </ul> <p style="text-align: center;">"Skip Job" <span style="float: right;">Stop Job</span></p>

**(7) Number of User Counters Assigned**

- It will not be displayed when the following setting shows that management device 2 is mounted.  
 [Service Mode] → [Billing Setting] → [Management Function Choice]

Functions	<ul style="list-style-type: none"> <li>To set the number available to be assigned for the user registration and account registration.</li> </ul>
Use	<ul style="list-style-type: none"> <li>To change the number available to be assigned for the user registration and account registration.</li> </ul>
Setting/ Procedure	<ul style="list-style-type: none"> <li>The default setting is 500.</li> <li>The total number to be registered for the user authentication and account track is 1000. The number for the user registration will be set.</li> </ul> When setting the [# of Counters Assigned for Users] to 50, the number available for Account Track will be 950.  <b>NOTE</b> <ul style="list-style-type: none"> <li><b>The setting is available only when carrying out the user authentication and account track.</b></li> </ul>

**(8) Ticket Hold Time Setting**

Functions	<ul style="list-style-type: none"> <li>Specify the desired length of holding time of Kerberos authentication ticket.</li> </ul>
Use	<b>NOTE</b> <ul style="list-style-type: none"> <li><b>This setting takes effect only when the authentication server type is set to active directory.</b></li> </ul>
Setting/ Procedure	<ul style="list-style-type: none"> <li>The default settings is 60 min.</li> </ul> <p style="text-align: right;">1 to 60 min.</p>

**(9) Scanner Settings**

- It will be displayed only when the optional image controller IC-409 is mounted and user authentication or account track has been set.

Functions	<ul style="list-style-type: none"> <li>To select whether to use TWAIN scan function available in Fiery Remote Scan when user authentication or account track is set to on.</li> </ul>
Use	<ul style="list-style-type: none"> <li>When user authentication or account track is set to on, select the use of TWAIN scan function available in Fiery Remote Scan software that is supplied with the image controller.</li> </ul>
Setting/ Procedure	<ul style="list-style-type: none"> <li>The default settings is Restrict.</li> </ul> <p style="text-align: center;">Allow <span style="float: right;">"Restrict"</span></p>

**B. User Authentication Setting**

- The settings are available only when carrying out the user authentication.

**(1) Administrative Setting**

<User Name List>

- It cannot select [OFF] when the following setting is set to “ON.”  
 [Administrator Settings] → [Security Settings] → [Enhanced Security Mode]

Functions	<ul style="list-style-type: none"> <li>• To set whether to display or not the list key for user names on user authentication screen.</li> </ul>
Use	<ul style="list-style-type: none"> <li>• To display the list key for user names on user authentication screen.</li> </ul>
Setting/ Procedure	<ul style="list-style-type: none"> <li>• The default setting is OFF.</li> </ul> <p style="text-align: center;">ON <span style="float: right;">“OFF”</span></p> <ul style="list-style-type: none"> <li>• <b>[ON] cannot be selected when [ON] is specified in the following setting.</b>                      [Administrator Settings] → [Security Settings] → [Enhanced Security Mode]</li> </ul>

<Default Function Permission>

Functions	<ul style="list-style-type: none"> <li>• To set the default value for the function permission in user authentication by the external server.</li> </ul>
Use	<ul style="list-style-type: none"> <li>• To set the function which authenticated user can use when initially authenticating the user by the external server.</li> <li>• Items available for setting: Copy, Scan, Fax, Print, User Box, Print Scan/Fax TX and Save to External Memory</li> </ul>
Setting/ Procedure	<ul style="list-style-type: none"> <li>• The default settings are Allow.</li> </ul> <p style="text-align: center;">“Allow” <span style="float: right;">Restrict</span></p>

 <ID & Print Settings>

- This is displayed only when the function enhanced version 2 or later firmware is installed.

Functions	<ul style="list-style-type: none"> <li>• To set whether to use ID &amp; Print (a job sent by a user cannot be printed until the user authentication is completed).</li> </ul>
Use	<ul style="list-style-type: none"> <li>• To set whether to print a job of unauthenticated or public user or to save the job into the ID &amp; Print User Box.</li> </ul>
Setting/ Procedure	<p>&lt;ID &amp; Print&gt;</p> <ul style="list-style-type: none"> <li>• The default setting is OFF.</li> </ul> <p style="text-align: center;">ON <span style="float: right;">“OFF”</span></p> <p>&lt;Public User&gt;</p> <ul style="list-style-type: none"> <li>• The default setting is Print Immediately.</li> </ul> <p style="text-align: center;">“Print Immediately” <span style="float: right;">Save</span></p>



- <ID & Print Operation Settings>
- This is displayed only when the function enhanced version 2 or later firmware is installed.
  - It will be displayed only when the following setting shows that authentication device is set to “installed”.  
 [Service Mode] → [Billing Setting] → [Management Function Choice]

Functions	• To set whether to print all jobs or only one job from the same authenticated user when ID & Print is selected.
Use	
Setting/ Procedure	• The default setting is Print All Jobs. <div style="display: flex; justify-content: space-around; margin-top: 10px;"> <span>“Print All Jobs”</span> <span>Print Each Job</span> </div>

### (2) User Registration

Functions	• To register or change the user.
Use	• To register, change or delete the user for authentication.
Setting/ Procedure	<ol style="list-style-type: none"> <li>1. Select the user, and touch [Edit]</li> <li>2. Input the user name, user password, and e-mail address.</li> </ol> <p><b>NOTE</b></p> <ul style="list-style-type: none"> <li>• <b>It cannot be entered when conducting authentication by external server.</b></li> </ul> <ol style="list-style-type: none"> <li>3. Set the output permission, max allowance set, function permission, and touch [OK].</li> </ol> <p><b>NOTE</b></p> <ul style="list-style-type: none"> <li>• <b>When the public users are allowed, the output permission and the function permission can be set.</b></li> <li>• <b>[Authentication Information Registration] does not appear when the presence of Authentication Device 2 is set in the following setting.</b>                      [Service Mode] → [Billing Setting] → [Management Function Choice]</li> <li>• <b>[Output Permission], [Max. Allowance Set], and [Function Permission] do not appear when the presence of Management Device 1 is set in the following setting.</b>                      [Service Mode] → [Billing Setting] → [Management Function Choice]</li> </ul>

### (3) User Counter

Functions	• To display the status of use of the copy+print, copy, print and scan/fax for each user.
Use	• To check the status of use of the copy+print, copy, print and scan/fax for each user.
Setting/ Procedure	<ol style="list-style-type: none"> <li>1. Select the user and touch [Counter Details].</li> <li>2. Select the key to check to see the status of use.</li> <li>3. For clearing the counter, touch [Clear Counter].</li> <li>4. For clearing the all counters, touch [Reset All Counters].</li> </ol>

**C. Account Track Setting**

- The settings are available only when carrying out the account track.

**(1) Account Track Registration**

Functions	<ul style="list-style-type: none"> <li>• To register and change the account.</li> </ul>
Use	<ul style="list-style-type: none"> <li>• To register, change or delete the account for account track.</li> </ul>
Setting/ Procedure	<ol style="list-style-type: none"> <li>1. Select the proper Account and touch [Edit].</li> <li>2. Input the [Account Name], [Password] and [Name].</li> <li>3. Set the [Output Permission], and [Max. Allowance Set], and touch [OK].</li> </ol> <p><b>NOTE</b></p> <ul style="list-style-type: none"> <li>• When the “Password Only” is selected for [Account Track Input Method], [Account Name] does not appear.</li> <li>• When the “Password Only” is selected for [Account Track Input Method], [Account Name] does not appear.</li> </ul>

**(2) Account Track Counter**

Functions	<ul style="list-style-type: none"> <li>• To display the status of use of the copy+print, copy, print and scan/fax for each account.</li> </ul>
Use	<ul style="list-style-type: none"> <li>• To check the status of use of the copy+print, copy, print and scan/fax for each account.</li> </ul>
Setting/ Procedure	<ol style="list-style-type: none"> <li>1. Select the account and touch [Counter Details].</li> <li>2. Select the key for the item to be checked.</li> <li>3. For clearing the counter, touch [Clear Counter].</li> <li>4. For clearing the all counters, touch [Reset All Counters].</li> </ol>

**D. Print without Authentication**

- It cannot select [Allow] when the following setting is set to “ON.”  
 [Administrator Settings] → [Security Settings] → [Enhanced Security Mode]

Functions	<ul style="list-style-type: none"> <li>• To set whether to allow or restrict the print which user and account are not specified.</li> </ul>
Use	<ul style="list-style-type: none"> <li>• To allow or restrict printing which user and account are not specified.</li> <li>• When Allow is selected, pages printed by unidentified users are counted and included in the count of the public user.</li> </ul>
Setting/ Procedure	<ul style="list-style-type: none"> <li>• The default setting is Restrict.</li> </ul> <p style="text-align: center;"> <span style="margin-right: 100px;">Allow</span> <span>“Restrict”</span> </p>

**E. Print Counter List**

- The setting is available only when carrying out the user authentication or account track.
- It will not be displayed when the following setting shows that key counter, vendor, authentication device1 or management device 2 is mounted.  
 [Service Mode] → [Billing Setting] → [Management Function Choice]

Functions	<ul style="list-style-type: none"> <li>• To print out the User counter and the account counter.</li> </ul>
Use	<ul style="list-style-type: none"> <li>• To output the user counter and account counter to be checked.</li> </ul>
Setting/ Procedure	<ol style="list-style-type: none"> <li>1. Touch [Counter List].</li> <li>2. Select the simplex or duplex print, and press the start key to output the counter list.</li> </ol>

### F. External Server Settings

Functions	<ul style="list-style-type: none"> <li>Registers and sets an external server that is used for user authentication.</li> </ul>
Use	<ul style="list-style-type: none"> <li>To make user authentication by external server authentication.</li> </ul>
Setting/ Procedure	<ol style="list-style-type: none"> <li>Select one from No. 1 to No. 20 and touch [NEW].</li> <li>Set [Server Name] and [Server Type].</li> <li>To change settings, select an external server to be edited and touch [Edit].</li> </ol> <p>&lt;Server Type&gt;</p> <p style="text-align: center;">Active Directory      NTLM v1      NTLM v2      NDS      LDAP</p> <p><b>NOTE</b></p> <ul style="list-style-type: none"> <li>Neither [NTLM v1] nor [NTLM v2] appear when OFF is selected in the following setting. [Administrator Settings] → [Network Settings] → [SMB Settings] → [User Authentication (NTLM)]</li> <li>[NDS] does not appear when OFF is selected in the following setting. [Administrator Settings] → [Network Settings] → [NetWare Settings] → [User Authentication Setting (NDS)]</li> </ul>

### G. Limiting Access to Destinations

#### (1) Create Group

Functions	<ul style="list-style-type: none"> <li>Registers and edits groups of destinations for limiting access.</li> </ul>
Use	
Setting/ Procedure	<ol style="list-style-type: none"> <li>Select a group and touch [Edit].</li> <li>Enter [Group Name].</li> <li>Set the Access Allowed Level and touch [OK].</li> </ol>

#### (2) Apply Levels/Groups to Destinations

Functions	<ul style="list-style-type: none"> <li>Sets Apply Level and Apply Group for individual destinations.</li> </ul>
Use	
Setting/ Procedure	<ol style="list-style-type: none"> <li>Select one from Address Book, Group, and Program.</li> <li>Select a registered address. Touch [Apply Group] and [Apply Level] independently to make each settings.</li> </ol>

#### (3) Apply Levels/Groups to Users

Functions	<ul style="list-style-type: none"> <li>Sets Apply Level or Apply Group for individual users.</li> </ul>
Use	
Setting/ Procedure	<ol style="list-style-type: none"> <li>Select a registered user. Touch [Apply Group] and [Apply Level] independently to make each settings.</li> </ol>

### H. Authentication Device Settings

- The function can be displayed only when the authentication device 2 is set to Set by [Service Mode] → [Billing Setting] → [Management Function Choice]

#### (1) General Settings



Functions	<ul style="list-style-type: none"> <li>Specifies a device used for user authentication.</li> </ul>
Use	<p>Card Authentication : Select the IC card type and operation settings.</p> <p>Bio Authentication : Select the beep and operation settings.</p>
Setting/ Procedure	<p style="text-align: center;">Card Authentication <span style="float: right;">Bio Authentication</span></p> <p><b>NOTE</b></p> <ul style="list-style-type: none"> <li>The screen displays the authentication device that is selected in [Service Mode] → [Billing Setting] → [Management Function Choice] → [Authentication Device 2].</li> <li>When [Card 2] is selected as authentication device, the authentication device name will be displayed differently depending on the type of installed loadable device driver.</li> </ul>

#### (2) Touch & Print Setting

Functions	<ul style="list-style-type: none"> <li>Specifies whether to store jobs in the touch &amp; print box when bio authentication is used.</li> </ul>
Use	
Setting/ Procedure	<ul style="list-style-type: none"> <li>The default setting is Yes.</li> </ul> <p style="text-align: center;">"Yes" <span style="float: right;">No</span></p>

#### (3) Logoff Settings

Functions	<ul style="list-style-type: none"> <li>Select whether or not the user is logged off after a scan or fax is sent or after the copy document is scanned.</li> </ul>
Use	
Setting/ Procedure	<ul style="list-style-type: none"> <li>The default setting is Do not log off.</li> </ul> <p style="text-align: center;">"Do not log off" <span style="float: right;">Log off</span></p>

### 8.6.5 Network Setting

#### A. TCP/IP Settings

##### (1) TCP/IP Settings

Functions	<ul style="list-style-type: none"> <li>To set whether to enable or disable TCP/IP settings.</li> </ul>
Use	
Setting/ Procedure	<ul style="list-style-type: none"> <li>The default setting is ON.</li> </ul> <p style="text-align: center;">"ON" <span style="float: right;">OFF</span></p> <p><b>NOTE</b></p> <ul style="list-style-type: none"> <li>When the setting is changed, turn off the main power switch and turn it on again more than 10 seconds after.</li> </ul>



**(2) IP Settings**

Functions	<ul style="list-style-type: none"> <li>To set whether to enter the IP address directly or to obtain it automatically.</li> </ul>														
Use	<ul style="list-style-type: none"> <li>To change the method for setting the IP address.</li> </ul>														
Setting/ Procedure	<ul style="list-style-type: none"> <li>The default setting is Auto Input.</li> </ul> <table style="width: 100%; border: none;"> <tr> <td style="text-align: center;">Manual Input</td> <td style="text-align: center;">"Auto Input"</td> </tr> </table> <ul style="list-style-type: none"> <li>When it is set to [Auto Input], select the method to obtain it automatically.</li> </ul> <table style="width: 100%; border: none;"> <tr> <td>DHCP Setting</td> <td style="text-align: center;">: ON</td> <td style="text-align: center;">OFF</td> </tr> <tr> <td>BOOTP Setting</td> <td style="text-align: center;">: ON</td> <td style="text-align: center;">OFF</td> </tr> <tr> <td>ARP/PING Setting</td> <td style="text-align: center;">: ON</td> <td style="text-align: center;">OFF</td> </tr> <tr> <td>AUTO IP Setting</td> <td style="text-align: center;">: ON</td> <td style="text-align: center;">OFF</td> </tr> </table> <p><b>NOTE</b></p> <ul style="list-style-type: none"> <li><b>[ARP/PING Setting] and [Auto IP Setting] cannot be set to "OFF" simultaneously.</b></li> <li><b>They will all be set to "ON" when [Manual Input] is changed to [Auto Input].</b></li> <li>When it is set to [Manual Input], set the IP address, subnet mask and default gate way.</li> </ul>	Manual Input	"Auto Input"	DHCP Setting	: ON	OFF	BOOTP Setting	: ON	OFF	ARP/PING Setting	: ON	OFF	AUTO IP Setting	: ON	OFF
Manual Input	"Auto Input"														
DHCP Setting	: ON	OFF													
BOOTP Setting	: ON	OFF													
ARP/PING Setting	: ON	OFF													
AUTO IP Setting	: ON	OFF													

**(3) DNS Host**

Functions	<ul style="list-style-type: none"> <li>To set the DNS host name.</li> <li>To set whether or not to enable the dynamic DNS setting.</li> </ul>		
Use	<ul style="list-style-type: none"> <li>To enter the DNS host name.</li> <li>To set the dynamic DNS.</li> </ul>		
Setting/ Procedure	<p>&lt;DNS Host Name&gt;</p> <ol style="list-style-type: none"> <li>Touch [DNS Host Name].</li> <li>Enter the DNS host name on the screen key board, and touch [OK].</li> </ol> <p>&lt;Dynamic DNS Settings&gt;</p> <ul style="list-style-type: none"> <li>The default setting is No Limit.</li> </ul> <table style="width: 100%; border: none;"> <tr> <td style="text-align: center;">Enable</td> <td style="text-align: center;">"No Limit"</td> </tr> </table>	Enable	"No Limit"
Enable	"No Limit"		

**(4) DNS Domain**

Functions	<ul style="list-style-type: none"> <li>To set whether or not to enable the auto obtaining for the DNS domain name.</li> <li>To set the DNS default domain name.</li> <li>To set the DNS search domain name.</li> </ul>		
Use	<ul style="list-style-type: none"> <li>To enter the DNS default domain name.</li> <li>To enter the DNS search domain name.</li> </ul>		
Setting/ Procedure	<p>&lt;DNS Domain Name Auto Retrieval&gt;</p> <ul style="list-style-type: none"> <li>The default setting is Enable.</li> </ul> <table style="width: 100%; border: none;"> <tr> <td style="text-align: center;">"Enable"</td> <td style="text-align: center;">No Limit</td> </tr> </table> <p><b>NOTE</b></p> <ul style="list-style-type: none"> <li><b>"Enable" cannot be set when [IP Settings] is set to "Auto Input."</b></li> </ul> <p>&lt;Domain Name&gt;</p> <ol style="list-style-type: none"> <li>Touch [Default DNS Domain Name] or [DNS Search Domain Name 1 to 3].</li> <li>Enter the domain name using the keyboard on the screen and touch [OK].</li> </ol>	"Enable"	No Limit
"Enable"	No Limit		

**(5) DNS Server Settings**

Functions	<ul style="list-style-type: none"> <li>To set whether or not to enable the auto obtaining of the DNS server address.</li> <li>To set the priority/substitute DNS server.</li> </ul>
Use	<ul style="list-style-type: none"> <li>To enter priority/substitute DNS server.</li> </ul>
Setting/ Procedure	<p>&lt;DNS Server Auto Obtain&gt;</p> <ul style="list-style-type: none"> <li>The default setting is Enable.</li> </ul> <p style="text-align: center;">“Enable” <span style="float: right;">No Limit</span></p> <p><b>NOTE</b></p> <ul style="list-style-type: none"> <li>“Enable” cannot be set when [IP Settings] is set to “Auto Input.”</li> </ul> <p>&lt;Priority/substitute DNS server.&gt;</p> <ul style="list-style-type: none"> <li>Touch the corresponding key, and input the server address by IPv4 or the IPv6 format.</li> </ul>

**(6) RAW Port Number**

Functions	<ul style="list-style-type: none"> <li>To set the RAW port number.</li> </ul>
Use	<ul style="list-style-type: none"> <li>To set the RAW port number for the printer.</li> <li>Several data can be accepted at the same time by selecting several ports.</li> </ul>
Setting/ Procedure	<ol style="list-style-type: none"> <li>Select the necessary port number.</li> <li>When using the selected port, press the Clear key to clear the value, and enter the RAW port number using the 10-key pad.</li> <li>Touch [OK].</li> </ol>

**(7) IP Filtering (Permit Access)**

Functions	<ul style="list-style-type: none"> <li>To set the IP filtering (Permit Access).</li> </ul>
Use	<ul style="list-style-type: none"> <li>To set whether to allow only IP addresses that are within a specified range.</li> </ul>
Setting/ Procedure	<ol style="list-style-type: none"> <li>Select Enable or “Disable”.</li> <li>When [Enable] is set, select one from Set 1 to Set 5 and specify the range of IP addresses to be allowed using the 10-key pad.</li> <li>Touch [OK].</li> </ol>

**(8) IP Filtering (Deny Access)**

Functions	<ul style="list-style-type: none"> <li>To set the IP filtering (Deny Access).</li> </ul>
Use	<ul style="list-style-type: none"> <li>When [Enable] is set, select one from Set 1 to Set 5 and specify the range of IP addresses to be allowed using the 10-key pad.</li> </ul>
Setting/ Procedure	<ol style="list-style-type: none"> <li>Select Enable or “Disable”.</li> <li>When [Enable] is set, select one from Set 1 to Set 5 and enter the range of IP addresses to be denied using the 10-key pad.</li> <li>Touch [OK].</li> </ol>

**(9) IPv6 Settings**

Functions	<ul style="list-style-type: none"> <li>To set whether to use IPv6 in IP network communication.</li> <li>To set whether to use the IPv6 address automatic acquisition setting.</li> <li>To set IPv6 addresses.</li> </ul>
Use	<ul style="list-style-type: none"> <li>To use IPv6 in IP network communication.</li> </ul>
Setting/ Procedure	<p>&lt;IPv6 Settings&gt;</p> <ul style="list-style-type: none"> <li>The default setting is ON.</li> </ul> <p style="text-align: center;">“ON” <span style="float: right;">OFF</span></p> <p>&lt;Auto IPv6 Settings&gt;</p> <ul style="list-style-type: none"> <li>The default setting is ON.</li> </ul> <p style="text-align: center;">“ON” <span style="float: right;">OFF</span></p> <p><b>NOTE</b></p> <ul style="list-style-type: none"> <li><b>When the setting is changed, turn off the main power switch and turn it on again more than 10 seconds after.</b></li> </ul> <p>&lt;IPv6 address&gt;</p> <ul style="list-style-type: none"> <li>When [Auto IPv6 Settings] is set to OFF, make the settings of global address and gateway address.</li> </ul> <ol style="list-style-type: none"> <li>Touch [Global Address] or [Gateway Address].</li> <li>Enter the address with the keys on the screen.</li> <li>To change the prefix length of global address, touch [Prefix Length] and specify the number of bits within the range of 1 to 128.</li> </ol> <p><b>NOTE</b></p> <ul style="list-style-type: none"> <li><b>[Link-Local Address] key appears, but its settings are not allowed to be changed.</b></li> </ul>

**(10) IPsec Settings**

Functions	<ul style="list-style-type: none"> <li>To set whether to use IPsec protocol for IP network communication.</li> </ul>
Use	<ul style="list-style-type: none"> <li>When IPsec protocol is used to perform encrypted communication.</li> </ul>
Setting/ Procedure	<ul style="list-style-type: none"> <li>The default setting is OFF.</li> </ul> <p style="text-align: center;">ON <span style="float: right;">“OFF”</span></p>

<IKE Settings>

Functions	<ul style="list-style-type: none"> <li>To make the settings that relate to IKE (Internet Key Exchange) protocol which is used for IPsec communication.</li> <li>Settings can be made independently for four different sets (Group 1 to 4).</li> </ul>							
Use								
Setting/ Procedure	<p>&lt;Group&gt;</p> <ul style="list-style-type: none"> <li>Among four groups (Group 1 to 4), select a group where settings are made.</li> </ul> <p>&lt;Encryption Algorithm&gt;</p> <ul style="list-style-type: none"> <li>Set a encryption algorithm used for IPsec communication.</li> <li>The default setting is OFF.</li> </ul> <table style="margin-left: 40px; border: none;"> <tr> <td style="padding-right: 20px;">DES_CBC</td> <td style="padding-right: 20px;">3DES_CBC</td> <td>"OFF"</td> </tr> </table> <p>&lt;Authentication Algorithm&gt;</p> <ul style="list-style-type: none"> <li>Set an authentication algorithm used for IPsec communication.</li> <li>The default setting is OFF.</li> </ul> <table style="margin-left: 40px; border: none;"> <tr> <td style="padding-right: 20px;">MD5</td> <td style="padding-right: 20px;">SHA-1</td> <td>"OFF"</td> </tr> </table> <p>&lt;Key Validity Period&gt;</p> <ul style="list-style-type: none"> <li>Set a key validity period.</li> <li>The default setting is 28800 (sec.).</li> </ul> <table style="margin-left: 40px; border: none;"> <tr> <td style="padding-right: 20px;">80 to 604800 (sec.)</td> </tr> </table> <p>&lt;Diffie-Hellman Group&gt;</p> <ul style="list-style-type: none"> <li>Set Diffie-Hellman group.</li> <li>The default setting is Group 2.</li> </ul>	DES_CBC	3DES_CBC	"OFF"	MD5	SHA-1	"OFF"	80 to 604800 (sec.)
DES_CBC	3DES_CBC	"OFF"						
MD5	SHA-1	"OFF"						
80 to 604800 (sec.)								

bizhub\_C353/C253/C203

Adjustment / Setting

<IPsec SA Settings>

Functions	<ul style="list-style-type: none"> <li>To make the settings that relate to IPsec SA (Security Association) which is used for IPsec communication.</li> <li>Settings can be made independently for eight different sets (Group 1 to 8).</li> </ul>																
Use																	
Setting/ Procedure	<p>&lt;Group Set Number&gt;</p> <ul style="list-style-type: none"> <li>Among Group 1 to 8, select a group where settings are made.</li> <li>After touching the key of the Group, make the following settings. (If the combination of each selection is not allowed among different settings, the key operation of the corresponding option is locked.)</li> </ul> <p>&lt;Security Protocol&gt;</p> <ul style="list-style-type: none"> <li>Set a security protocol.</li> <li>The default setting is OFF.</li> </ul> <table style="width: 100%; border: none;"> <tr> <td style="text-align: center;">AH</td> <td style="text-align: center;">ESP</td> <td style="text-align: center;">ESP_AH</td> <td style="text-align: right;">"OFF"</td> </tr> </table> <p>&lt;ESP Encryption Algorithm&gt;</p> <ul style="list-style-type: none"> <li>Set an encryption algorithm used for ESP protocol.</li> <li>The default setting is OFF.</li> </ul> <table style="width: 100%; border: none;"> <tr> <td style="text-align: center;">DES_CBC</td> <td style="text-align: center;">3DES_CBC</td> <td style="text-align: center;">AES_CBC</td> <td style="text-align: center;">AES_CTR</td> <td style="text-align: center;">NULL</td> <td style="text-align: right;">"OFF"</td> </tr> </table> <p>&lt;ESP Authentication Algorithm&gt;</p> <ul style="list-style-type: none"> <li>Set authentication algorithm used for ESP protocol.</li> <li>The default setting is OFF.</li> </ul> <table style="width: 100%; border: none;"> <tr> <td style="text-align: center;">MD5</td> <td style="text-align: center;">SHA-1</td> <td style="text-align: right;">"OFF"</td> </tr> </table> <p>&lt;AH Authentication Algorithm&gt;</p> <ul style="list-style-type: none"> <li>Set authentication algorithm used for AH protocol.</li> <li>The default setting is OFF.</li> </ul> <table style="width: 100%; border: none;"> <tr> <td style="text-align: center;">MD5</td> <td style="text-align: center;">SHA-1</td> <td style="text-align: right;">"OFF"</td> </tr> </table> <p>&lt;Lifetime After Establishing SA&gt;</p> <ul style="list-style-type: none"> <li>Set the period of time starting from when SA connection is established and ending when the SA connection is cut.</li> <li>The default setting is 3600 (sec.).</li> </ul> <p style="text-align: center;">120 to 604800 (sec.)</p>	AH	ESP	ESP_AH	"OFF"	DES_CBC	3DES_CBC	AES_CBC	AES_CTR	NULL	"OFF"	MD5	SHA-1	"OFF"	MD5	SHA-1	"OFF"
AH	ESP	ESP_AH	"OFF"														
DES_CBC	3DES_CBC	AES_CBC	AES_CTR	NULL	"OFF"												
MD5	SHA-1	"OFF"															
MD5	SHA-1	"OFF"															

bizhub C353/C253/C203

Adjustment / Setting

<Peer>

Functions	<ul style="list-style-type: none"> <li>To register destinations used for IPsec communication.</li> </ul>						
Use	<ul style="list-style-type: none"> <li>Settings can be made independently for different ten sets (Group 1 to 10).</li> </ul>						
Setting/ Procedure	<p>&lt;Peer&gt;</p> <ul style="list-style-type: none"> <li>Among Group 1 to 10, select a group where settings are made.</li> <li>After touching the key of the Group, make the following setting.</li> </ul> <p>&lt;Encapsulation Mode&gt;</p> <ul style="list-style-type: none"> <li>Set a encapsulation mode used for IPsec.</li> <li>The default setting is OFF.</li> </ul> <table border="0" style="width: 100%; text-align: center;"> <tr> <td style="width: 33%;">Tunnel Mode</td> <td style="width: 33%;">Transport Mode</td> <td style="width: 33%;">"OFF"</td> </tr> </table> <p>&lt;IP Address&gt;</p> <ul style="list-style-type: none"> <li>When the encapsulation mode is set, specify the IP address of destinations.</li> <li>Touch [IP Address] and enter the IP address with IPv4 or IPv6 format.</li> </ul> <p>&lt;Pre-Shared Key Text&gt;</p> <ul style="list-style-type: none"> <li>When the encapsulation mode is set, specify a Pre-shared key (Key data).</li> <li>Touch [Input] and enter the Pre-shared key.</li> </ul> <p>&lt;Perfect Forward Secrecy&gt;</p> <ul style="list-style-type: none"> <li>When the transport mode is selected, set whether to use Perfect forward secrecy.</li> <li>The default setting is OFF.</li> </ul> <table border="0" style="width: 100%; text-align: center;"> <tr> <td style="width: 33%;">ON</td> <td style="width: 33%;"></td> <td style="width: 33%;">"OFF"</td> </tr> </table>	Tunnel Mode	Transport Mode	"OFF"	ON		"OFF"
Tunnel Mode	Transport Mode	"OFF"					
ON		"OFF"					

**B. NetWare Settings**

**(1) IPX Settings**

Functions	<ul style="list-style-type: none"> <li>To enable or disable the NetWare (IPX) setting.</li> <li>To set the ethernet frame type.</li> </ul>								
Use	<ul style="list-style-type: none"> <li>To use NetWare (IPX) setting.</li> <li>To specify the frame type for transmission.</li> </ul>								
Setting/ Procedure	<p>&lt;IPX Settings&gt;</p> <ul style="list-style-type: none"> <li>The default setting is ON.</li> </ul> <table border="0" style="width: 100%; text-align: center;"> <tr> <td style="width: 33%;">"ON"</td> <td style="width: 33%;"></td> <td style="width: 33%;">OFF</td> </tr> </table> <p>&lt;Ethernet Frame Type&gt;</p> <ul style="list-style-type: none"> <li>The default setting is Auto Detect.</li> </ul> <table border="0" style="width: 100%; text-align: center;"> <tr> <td style="width: 25%;">"Auto Detect"</td> <td style="width: 12.5%;">802.2</td> <td style="width: 12.5%;">802.3</td> <td style="width: 12.5%;">Ethernet II</td> <td style="width: 12.5%;">802.3SNAP</td> </tr> </table>	"ON"		OFF	"Auto Detect"	802.2	802.3	Ethernet II	802.3SNAP
"ON"		OFF							
"Auto Detect"	802.2	802.3	Ethernet II	802.3SNAP					

bizhub\_C353/C253/C203

Adjustment / Setting

**(2) Netware Print Settings**

Functions	<ul style="list-style-type: none"> <li>To set whether to use the NetWare print mode.</li> <li>To set the NetWare print mode.</li> <li>To display NetWare status.</li> </ul>
Use	<ul style="list-style-type: none"> <li>To change the NetWare print mode.</li> <li>To check NetWare status.</li> </ul>
Setting/ Procedure	<p>&lt;Netware Print Settings&gt;</p> <ul style="list-style-type: none"> <li>The default setting is ON.</li> </ul> <p style="text-align: center;">“ON” <span style="float: right;">OFF</span></p> <p>&lt;NetWare Print Mode&gt;</p> <ul style="list-style-type: none"> <li>The default setting is PServer.</li> </ul> <p style="text-align: center;">“PServer” <span style="float: right;">Nprinter/Rprinter</span></p> <ul style="list-style-type: none"> <li>After selecting either key in the NetWare print mode setting, proceed to each setting screen.</li> </ul> <p>&lt;Status&gt;</p> <ol style="list-style-type: none"> <li>Touch [Status].</li> <li>Touch up/down arrow keys to select the server to check.</li> <li>Check the NetWare status.</li> </ol>

**(3) P Server Settings: Print Server Name/Print Server Password**

Functions	<ul style="list-style-type: none"> <li>To set the print server name and print server password.</li> </ul>
Use	<ul style="list-style-type: none"> <li>To enter the print server name or the print server password.</li> </ul>
Setting/ Procedure	<ol style="list-style-type: none"> <li>Touch [Print Server name] or [Print Server Password].</li> <li>Enter the print server name or the print server password (up to 63 characters) using the on-screen keyboard, and touch [OK].</li> </ol>

**(4) P Server Settings: Polling Interval**

Functions	<ul style="list-style-type: none"> <li>To set the polling interval.</li> </ul>
Use	<ul style="list-style-type: none"> <li>To set the interval to search the print queue.</li> </ul>
Setting/ Procedure	<ol style="list-style-type: none"> <li>Press the Clear key.</li> <li>Enter the polling interval between 1 and 65535 using the 10-key pad.</li> </ol>

**(5) P Server Settings: NDS/Bindery Setting**

Functions	<ul style="list-style-type: none"> <li>To set whether to enable or disable the bindery setting when using NetWare4.x model and after.</li> </ul>
Use	<ul style="list-style-type: none"> <li>To enable the bindery service.</li> </ul>
Setting/ Procedure	<ul style="list-style-type: none"> <li>The default setting is NDS.</li> </ul> <p style="text-align: center;">“NDS” <span style="float: right;">NDS/Bindery</span></p>

**(6) P Server Settings: File Server Name**

Functions	<ul style="list-style-type: none"> <li>To set the file server name.</li> </ul>
Use	<ul style="list-style-type: none"> <li>To set the full server name for the print server to logon.</li> </ul>
Setting/ Procedure	<ol style="list-style-type: none"> <li>Touch [File Server Name].</li> <li>Enter the File server name (up to 47 characters) on the on-screen keyboard, and touch [OK].</li> </ol>

**(7) P Server Settings: NDS Context Name**

Functions	<ul style="list-style-type: none"> <li>To set the NDS context name (context name to register NDS print server).</li> </ul>
Use	<ul style="list-style-type: none"> <li>To set the NDS context name.</li> </ul>
Setting/ Procedure	<ol style="list-style-type: none"> <li>Touch [NDS Context name].</li> <li>Enter the NDS context name (up to 191 characters) on the on-screen keyboard, and touch [OK].</li> </ol>

**(8) P Server Settings: NDS Tree Name**

Functions	<ul style="list-style-type: none"> <li>To set the NDS tree name (name to login).</li> </ul>
Use	<ul style="list-style-type: none"> <li>To set the NDS tree name.</li> </ul>
Setting/ Procedure	<ol style="list-style-type: none"> <li>Touch [NDS Tree Name].</li> <li>Enter the NDS tree name (up to 63 characters) on the on-screen keyboard, and touch [OK].</li> </ol>

**(9) Nprinter/Rprinter Settings: Print Server Name**

Functions	<ul style="list-style-type: none"> <li>To set the print server name.</li> </ul>
Use	<ul style="list-style-type: none"> <li>To set the print server name.</li> </ul>
Setting/ Procedure	<ol style="list-style-type: none"> <li>Touch [Print Server Name].</li> <li>Enter the printer name (up to 63 characters) on the on-screen keyboard, and touch [OK].</li> </ol>

**(10) Nprinter/Rprinter Settings: Printer Number**

Functions	<ul style="list-style-type: none"> <li>To set the printer number.</li> </ul>
Use	<ul style="list-style-type: none"> <li>To set the printer number.</li> </ul>
Setting/ Procedure	<ol style="list-style-type: none"> <li>Touch [Auto] and cancel the reverse display.</li> <li>Press the Clear key.</li> <li>Enter the number between 0 and 254 using the 10-key pad.</li> </ol>

**(11) User Authentication Setting (NDS)**

Functions	<ul style="list-style-type: none"> <li>To set whether or not to use the user authentication setting.</li> </ul>
Use	<ul style="list-style-type: none"> <li>To conduct user authentication in netware environment.</li> </ul>
Setting/ Procedure	<ul style="list-style-type: none"> <li>The default setting is ON.</li> </ul> <p style="text-align: center;">"ON" <span style="margin-left: 200px;">OFF</span></p>



**C. http Server Settings**

- It will not be displayed when the following setting shows that authentication device is mounted.

[Service Mode] → [Billing Setting] → [Management Function Choice]

**(1) http Server Settings**

Functions	<ul style="list-style-type: none"> <li>To set whether or not to use the http server setting.</li> </ul>
Use	
Setting/ Procedure	<ul style="list-style-type: none"> <li>The default setting is ON.</li> </ul> <p style="text-align: center;">“ON” <span style="float: right;">OFF</span></p>

**(2) PSWC Settings**

Functions	<ul style="list-style-type: none"> <li>To set whether to use the PageScope Web Connection.</li> </ul>
Use	
Setting/ Procedure	<ul style="list-style-type: none"> <li>The default setting is ON.</li> </ul> <p style="text-align: center;">“ON” <span style="float: right;">OFF</span></p>

**(3) IPP Settings**

Functions	<ul style="list-style-type: none"> <li>To set whether to enable or disable IPP (Internet Printing Protocol) setting.</li> </ul>
Use	
Setting/ Procedure	<ul style="list-style-type: none"> <li>The default setting is ON.</li> </ul> <p style="text-align: center;">“ON” <span style="float: right;">OFF</span></p>

**(4) Accept IPP jobs**

Functions	<ul style="list-style-type: none"> <li>To set whether to allow or restrict the IPP job.</li> </ul>
Use	
Setting/ Procedure	<ul style="list-style-type: none"> <li>The default setting is ON.</li> </ul> <p style="text-align: center;">“ON” <span style="float: right;">OFF</span></p>

**(5) Support Information**

Functions	<ul style="list-style-type: none"> <li>To set the operation support information.</li> </ul>
Use	<ul style="list-style-type: none"> <li>For the response setting to see if IPP transmission supports each function.</li> </ul>
Setting/ Procedure	<ol style="list-style-type: none"> <li>Touch [Support Information].</li> <li>Set “ON” or OFF for each item.</li> </ol>

**(6) Printer Information**

Functions	<ul style="list-style-type: none"> <li>To set the printer information.</li> </ul>
Use	<ul style="list-style-type: none"> <li>To set the printer information.</li> </ul>
Setting/ Procedure	<ol style="list-style-type: none"> <li>Touch [Printer Information].</li> <li>Enter the printer name, printer location, and printer information on the on-screen keyboard.</li> <li>Touch [Print URI] to check the printer URI information.</li> </ol>

**(7) IPP Authentication Settings**

Functions	• To set whether or not to use the IPP authentication setting.
Use	• To conduct IPP authentication.
Setting/ Procedure	• The default setting is ON.  "ON" OFF

**(8) Authentication Method**

Functions	• To set the authentication method for IPP authentication.
Use	• To change the authentication method when conducting IPP authentication.
Setting/ Procedure	• The default setting is requesting-user-name.  "requesting-user-name" basic digest

**(9) User Name**

Functions	• To set the user name for IPP authentication.
Use	
Setting/ Procedure	1. Touch [User Name]. 2. Enter the user name on the on-screen keyboard, and touch [OK].

**(10) Password**

Functions	• To set the password for IPP authentication.
Use	
Setting/ Procedure	1. Touch [Password]. 2. Enter the password on the on-screen keyboard, and touch [OK].

**(11) realm**

Functions	• To set the realm for identifying the authentication setting for IPP authentication.
Use	
Setting/ Procedure	1. Touch [realm]. 2. Enter the realm on the on-screen keyboard, and touch [OK].

**D. FTP Settings**

**(1) FTP TX Settings**

Functions	• To set whether to use FTP TX settings.
Use	
Setting/ Procedure	• The default setting is ON.  "ON" OFF

**(2) FTP TX Settings: Proxy Server Address**

Functions	<ul style="list-style-type: none"> <li>To set the proxy server address.</li> </ul>
Use	<ul style="list-style-type: none"> <li>To enter the proxy server address.</li> </ul>
Setting/ Procedure	<ol style="list-style-type: none"> <li>Touch [Host Address].</li> <li>Select [Input Host Name], [IPv4 Address Input], or [IPv6 Address Input] and enter a host address.</li> </ol>

**(3) FTP TX Settings: Proxy Server Port Number**

Functions	<ul style="list-style-type: none"> <li>To set the proxy server port number.</li> </ul>
Use	<ul style="list-style-type: none"> <li>To enter the proxy server port number.</li> </ul>
Setting/ Procedure	<ul style="list-style-type: none"> <li>Press the Clear key.</li> <li>Enter the proxy server port number between 1 and 65535 using the 10-key pad.</li> </ul>

**(4) FTP TX Settings: Port No.**

Functions	<ul style="list-style-type: none"> <li>To set the port number to be used for transmission with FTP server.</li> </ul>
Use	<ul style="list-style-type: none"> <li>To enter the port number to be used for transmission with FTP server.</li> </ul>
Setting/ Procedure	<ol style="list-style-type: none"> <li>Touch [Input].</li> <li>Press the Clear key.</li> <li>Enter the proxy server port number between 1 and 65535 using the 10-key pad.</li> </ol>

**(5) FTP TX Settings: Connection Timeout**

Functions	<ul style="list-style-type: none"> <li>To set the timeout period for connecting to FTP server.</li> </ul>
Use	<ul style="list-style-type: none"> <li>To change the timeout period for connecting.</li> </ul>
Setting/ Procedure	<ol style="list-style-type: none"> <li>Touch [Input].</li> <li>Press the Clear key.</li> <li>Enter the connecting timeout period between 5 and 300 using the 10-key pad.</li> </ol>

**(6) FTP Server Settings**

Functions	<ul style="list-style-type: none"> <li>To set whether to use this machine as FTP server.</li> </ul>
Use	<ul style="list-style-type: none"> <li>Not to use the machine as FTP server.</li> </ul>
Setting/ Procedure	<ul style="list-style-type: none"> <li>The default setting is ON.</li> </ul> <p style="text-align: center;">"ON" <span style="margin-left: 200px;">OFF</span></p> <p><b>NOTE</b></p> <ul style="list-style-type: none"> <li>[ON] cannot be selected when the following setting is set to "ON."                      [Administrator Settings] → [Security Settings] → [Enhanced Security Mode]</li> </ul>

**E. SMB Setting**

- It will not be displayed when the following setting shows that authentication device is mounted.

[Service Mode] → [Billing Setting] → [Management Function Choice]

**(1) Client Settings**

Functions	<ul style="list-style-type: none"> <li>To set whether or not to use the SMB transmission setting.</li> <li>To set whether or not to enable the user authentication setting by NTLM.</li> <li>To set the NTLM version for the user authentication.</li> </ul>
Use	<ul style="list-style-type: none"> <li>To use when setting the SMB transmission setting.</li> <li>To use when conducting the user authentication by NTLM (NT LAN Manager).</li> <li>To use when changing the NTLM version for user authentication. NTLM has v1 and v2. Select the version which suits the network environment.</li> </ul>
Setting/ Procedure	<p>&lt;Client Settings&gt;</p> <ul style="list-style-type: none"> <li>The default setting is ON.</li> </ul> <p style="text-align: center;">"ON" <span style="float: right;">OFF</span></p> <p>&lt;NTLM Settings&gt;</p> <ul style="list-style-type: none"> <li>The default setting is v1.</li> </ul> <p style="text-align: center;">"v1" <span style="margin-left: 100px;">v2</span> <span style="float: right;">v1/v2</span></p> <p>&lt;User Authentication (NTLM)&gt;</p> <ul style="list-style-type: none"> <li>The default setting is ON.</li> </ul> <p style="text-align: center;">"ON" <span style="float: right;">OFF</span></p>

**(2) Print Settings**

Functions	<ul style="list-style-type: none"> <li>To set whether to use SMB port or not in printer mode.</li> </ul>
Use	
Setting/ Procedure	<ul style="list-style-type: none"> <li>The default setting is ON.</li> </ul> <p style="text-align: center;">"ON" <span style="float: right;">OFF</span></p>

**(3) Print Settings: NetBIOS Name**

Functions	<ul style="list-style-type: none"> <li>To set NetBIOS name.</li> </ul>
Use	<ul style="list-style-type: none"> <li>To set NetBIOS name.</li> </ul>
Setting/ Procedure	<ol style="list-style-type: none"> <li>Touch [NetBIOS Name].</li> <li>Enter the NetBIOS name (up to 15 characters) on the on-screen keyboard, and touch [OK].</li> </ol>

**(4) Print Settings: Print Service Name**

Functions	<ul style="list-style-type: none"> <li>To set the print service name.</li> </ul>
Use	<ul style="list-style-type: none"> <li>To set the print service name.</li> </ul>
Setting/ Procedure	<ol style="list-style-type: none"> <li>Touch [Print Service Name].</li> <li>Enter the print service name (up to 13 characters) on the on-screen keyboard, and touch [OK].</li> </ol>

**(5) Print Settings: Workgroup**

Functions	<ul style="list-style-type: none"> <li>To set the workgroup.</li> </ul>
Use	<ul style="list-style-type: none"> <li>To set the workgroup.</li> </ul>
Setting/ Procedure	<ol style="list-style-type: none"> <li>Touch [Workgroup].</li> <li>Enter the workgroup (up to 15 characters) on the on-screen keyboard, and touch [OK].</li> </ol>

**(6) WINS Settings**

Functions	<ul style="list-style-type: none"> <li>To set whether or not to enable the WINS setting.</li> </ul>
Use	<ul style="list-style-type: none"> <li>To use the WINS (Windows Internet Name Service) setting is necessary.</li> <li>By using the WINS, the traffic by broadcast can be reduced, and the communication becomes available with the network where broadcast does not reach.</li> </ul>
Setting/ Procedure	<ul style="list-style-type: none"> <li>The default setting is ON.</li> </ul> <p style="text-align: center;">"ON" <span style="margin-left: 200px;">OFF</span></p>

**(7) WINS Settings: Automatic Retrieval Settings**

Functions	<ul style="list-style-type: none"> <li>To set whether or not to enable the auto obtaining of the WINS server address.</li> </ul>
Use	<ul style="list-style-type: none"> <li>To acquire the WINS server address automatically.</li> <li>To obtain the WINS server address from DHCP server. If there are more than one address settings, up to two can be acquired.</li> </ul>
Setting/ Procedure	<ul style="list-style-type: none"> <li>The default setting is Enable.</li> </ul> <p style="text-align: center;">"Enable" <span style="margin-left: 200px;">No Limit</span></p>

**(8) WINS Settings: WINS Server Address 1, 2**

Functions	<ul style="list-style-type: none"> <li>To set the WINS server address.</li> </ul>
Use	<ul style="list-style-type: none"> <li>To use when manually entering the WINS server address.</li> <li>The primary address and the secondary address can be set. (The primary address has the priority during operation.)</li> </ul>
Setting/ Procedure	<ol style="list-style-type: none"> <li>Touch [1] or [2].</li> <li>Enter the WINS server address.</li> </ol>

**(9) WINS Settings: Node Type Setting**

Functions	<ul style="list-style-type: none"> <li>To set a node type.</li> </ul>
Use	<ul style="list-style-type: none"> <li>To change the current node type.</li> </ul>
Setting/ Procedure	<ul style="list-style-type: none"> <li>The default setting is H Node.</li> </ul> <p style="text-align: center;">B Node          P Node          N Node          "H Node"</p>

**(10) Direct Hosting Setting**

Functions	<ul style="list-style-type: none"> <li>To set whether or not to enable the direct hosting setting.</li> </ul>
Use	<ul style="list-style-type: none"> <li>To use the direct hosting setting is necessary.</li> </ul>
Setting/ Procedure	<ul style="list-style-type: none"> <li>The default setting is ON.</li> </ul> <p style="text-align: center;">"ON" <span style="margin-left: 200px;">OFF</span></p>

**F. LDAP Settings**

- It will not be displayed when the following setting shows that authentication device is mounted.

[Service Mode] → [Billing Setting] → [Management Function Choice]

**(1) Enabling LDAP**

Functions	• To set whether to enable or disable the LDAP function.
Use	• To use LDAP function.
Setting/ Procedure	• The default setting is OFF.  ON "OFF"

**(2) Setting Up LDAP**

- Registration and/or setting concerning the LDAP server can be conducted.
- Touch [Setting Up LDAP], and select the optional blank key to register and/or set.

<LDAP Server Name>

Functions	• Set the LDAP server name.
Use	
Setting/ Procedure	1. Touch [Server Name]. 2. Enter the server name (up to 32 one-byte characters) on the on-screen keyboard, and touch [OK].

<Max. Search Results>

Functions	• To set the Max. results of address for LDAP search.
Use	• To change the Max. results of address for LDAP search.
Setting/ Procedure	1. Touch [Max. Search Results]. 2. Press the Clear key. 3. Enter the Max. Search result numbers between 5 and 1000 using the 10-key pad.

<Timeout>

Functions	• To set the Max. timeout period for LDAP search.
Use	• To change the Max. timeout period for LDAP search.
Setting/ Procedure	1. Touch [Timeout]. 2. Press the Clear key. 3. Enter the timeout period between 5 and 300 using the 10-key pad.

<Initial Setting for Search Details>

Functions	• To set the initial items for search conditions in LDAP detail search.
Use	• To set the initial items for search conditions in LDAP detail search.
Setting/ Procedure	1. Touch [Initial Setting for Search Details]. 2. Touch the key about condition for each search item, and select the condition.



<Port Number (SSL)>

Functions	<ul style="list-style-type: none"> <li>To set the port number for LDAP server when using SSL.</li> </ul>
Use	<ul style="list-style-type: none"> <li>To enter the port number for LDAP server when using SSL.</li> </ul>
Setting/ Procedure	<ol style="list-style-type: none"> <li>Touch [Input].</li> <li>Press the Clear key.</li> <li>Enter the port number between 1 and 65535 using the 10-key pad.</li> </ol>

<Authentication Type>

Functions	<ul style="list-style-type: none"> <li>To set the authentication method to logon to LDAP server.</li> </ul>
Use	<ul style="list-style-type: none"> <li>To change the authentication method to logon to LDAP server. <ul style="list-style-type: none"> <li>anonymous : User name and password are not necessary (Dynamic authentication will be invalid when anonymous is selected.)</li> <li>Simple : Simple method which needs the user name and the password</li> <li>Digest-MD5 : Method available with normal LDAP server. When failing to authenticate with Digest-MD5, it automatically switches to CRAM-MD5.</li> <li>GSS-SPNEGO : Method available with Windows active directory (Kerberos authentication).</li> <li>NTLM (v1) : Standard user authentication format used for Windows NT, etc.</li> <li>NTLM (v2) : Standard user authentication format used for Windows NT, etc. It has been applied to the Windows NT4.0 SP4 and later versions. Its security has been enhanced compared to v1.</li> </ul> </li> </ul>
Setting/ Procedure	<ul style="list-style-type: none"> <li>The default setting is anonymous.</li> </ul> <p>“anonymous” Simple Digest-MD5 GSS-SPNEGO NTLM v1 NTLM v2</p>

<Select Server Authentication Method>

Functions	<ul style="list-style-type: none"> <li>To set the authentication system when conducting LDAP server authentication.</li> </ul>
Use	<ul style="list-style-type: none"> <li>To use when changing the server authentication system. <ul style="list-style-type: none"> <li>Use Set Value : It conducts authentication with the setting value set by [LDAP Server Registration].</li> <li>Use User Authentication ID and Password : It conducts authentication with the registration data for the copier’s user authentication.</li> <li>Dynamic Authentication : It conducts authentication by dynamic authentication.</li> </ul> </li> </ul>
Setting/ Procedure	<ul style="list-style-type: none"> <li>The default setting is Use Set Value.</li> </ul> <p>“Use Set Value” Use User Authentication ID and Password Nprinter/Rprinter</p>

<Referral Setting>

Functions	<ul style="list-style-type: none"> <li>To set whether or not to use the referral setting.</li> </ul>
Use	<ul style="list-style-type: none"> <li>To use when tracing the server with referral at the time of LDAP connection.</li> </ul>
Setting/ Procedure	<ul style="list-style-type: none"> <li>The default setting is ON.</li> </ul> <p>“ON” OFF</p>



<Login Name>

Functions	<ul style="list-style-type: none"> <li>To set the login name to connect to LDAP server.</li> </ul>
Use	<ul style="list-style-type: none"> <li>To set the login name to connect to LDAP server.</li> </ul>
Setting/ Procedure	<ol style="list-style-type: none"> <li>Touch [Login Name].</li> <li>Enter the logon name (up to 255 characters) on the on-screen keyboard, and touch [OK].</li> </ol> <p><b>NOTE</b></p> <ul style="list-style-type: none"> <li>The setting is not available when authentication method is set to anonymous.</li> </ul>

<Password>

Functions	<ul style="list-style-type: none"> <li>To set the password for connecting to LDAP server.</li> </ul>
Use	<ul style="list-style-type: none"> <li>To set the password for connecting to LDAP server.</li> </ul>
Setting/ Procedure	<ul style="list-style-type: none"> <li>Touch [Password].</li> <li>Enter the password (up to 63 characters) on the on-screen keyboard, and touch [OK].</li> </ul> <p><b>NOTE</b></p> <ul style="list-style-type: none"> <li>The setting is not available when authentication method is set to anonymous.</li> </ul>

<Domain Name>

Functions	<ul style="list-style-type: none"> <li>To set the domain name for connecting to LDAP server.</li> </ul>
Use	<ul style="list-style-type: none"> <li>To set the domain name for connecting to LDAP server.</li> </ul>
Setting/ Procedure	<ol style="list-style-type: none"> <li>Touch [Domain Name].</li> <li>Enter the domain name (up to 64 characters) on the on-screen keyboard, and touch [OK].</li> </ol>

**(3) Default LDAP Server Setting**

Functions	<ul style="list-style-type: none"> <li>To set the server to be used as the default when searching LDAP.</li> </ul>
Use	
Setting/ Procedure	<ol style="list-style-type: none"> <li>Touch [Default LDAP Server Setting].</li> <li>Select the optional server.</li> </ol>

**G. E-mail Settings**

- It will not be displayed when the following setting shows that authentication device is mounted.

[Service Mode] → [Billing Setting] → [Management Function Choice]

**(1) E-mail TX (SMTP)**

<E-mail TX (SMTP)>

Functions	<ul style="list-style-type: none"> <li>To set whether to enable or disable the e-mail transmission setting.</li> </ul>
Use	<ul style="list-style-type: none"> <li>To disable the e-mail transmission setting.</li> </ul>
Setting/ Procedure	<ul style="list-style-type: none"> <li>The default setting is ON.</li> </ul> <p style="text-align: center;">“ON” <span style="margin-left: 200px;">OFF</span></p>

## &lt;Scan to E-mail&gt;

Functions	• To set whether or not to transfer scanned data by e-mail.
Use	• To use when not transferring scanned data by e-mail.
Setting/ Procedure	• The default setting is ON.  "ON" OFF

## &lt;Status Notification&gt;

Functions	• To set whether or not to inform the status by e-mail.
Use	• To use when not informing the status by e-mail.
Setting/ Procedure	• The default setting is ON.  "ON" OFF

## &lt;Total Counter Notification&gt;

Functions	• To set whether or not to inform the total counter by e-mail.
Use	• To use when not informing the total counter by e-mail.
Setting/ Procedure	• The default setting is ON.  "ON" OFF

## &lt;SMTP Server Address&gt;

Functions	• To set the SMTP server address.
Use	• To enter the SMTP server address.
Setting/ Procedure	1. Touch [Host Address]. 2. Select [Input Host Name], [IPv4 Address Input] or [IPv6 Address Input], and enter the server address.

## &lt;Binary Division&gt;

Functions	• To set whether to carry out binary division for data to be transmitted.
Use	• Not to carry out binary division for data to be transmitted.
Setting/ Procedure	• The default setting is OFF.  ON "OFF"

## &lt;Divided Mail Size&gt;

Functions	• To set the dividing size when carrying out the binary division for data to be transmitted.
Use	• To change the dividing size of the data.
Setting/ Procedure	1. Press the Clear key. 2. Enter the dividing mail size between 100 and 15000 (in 100 increments) using the 10-key pad.

<Connection Timeout>

Functions	<ul style="list-style-type: none"> <li>To set the timeout period for connection in transmitting e-mail to SMTP server.</li> </ul>
Use	<ul style="list-style-type: none"> <li>To change the timeout period for connection in transmitting e-mail to SMTP server.</li> </ul>
Setting/ Procedure	<ul style="list-style-type: none"> <li>Select the timeout period using [+] / [-] keys.</li> <li>The default setting is 60 sec.</li> </ul> <p style="text-align: center;">"60 sec." (30 to 300, in 30 sec. increments)</p>

<Server Capacity>

Functions	<ul style="list-style-type: none"> <li>To set the Max. capacity per mail which SMTP server can receive.</li> </ul>
Use	<ul style="list-style-type: none"> <li>To change the Max. capacity per mail which SMTP server can receive.</li> </ul>
Setting/ Procedure	<ul style="list-style-type: none"> <li>The default setting is No Limit.</li> </ul> <p style="text-align: center;">"No Limit" (1 to 100)</p>

<SSL Setting>

Functions	<ul style="list-style-type: none"> <li>To set whether or not to use SSL when sending an e-mail.</li> </ul>
Use	<ul style="list-style-type: none"> <li>To use when sending an e-mail using SSL.</li> </ul>
Setting/ Procedure	<ul style="list-style-type: none"> <li>The default setting is OFF.</li> </ul> <p style="text-align: center;">SMTP over SSL                      Start TLS                      "OFF"</p>

<Port No.>

Functions	<ul style="list-style-type: none"> <li>To set the port number for transmission with SMTP server.</li> </ul>
Use	<ul style="list-style-type: none"> <li>To enter the port number for transmission with SMTP server.</li> </ul>
Setting/ Procedure	<ol style="list-style-type: none"> <li>Touch [Input].</li> <li>Press the Clear key.</li> <li>Enter the port number between 1 and 65535 using the 10-key pad.</li> </ol>

<Port Number (SSL)>

Functions	<ul style="list-style-type: none"> <li>To set the port number when using SSL.</li> </ul>
Use	<ul style="list-style-type: none"> <li>To use for entering the port number when using SSL.</li> </ul>
Setting/ Procedure	<ol style="list-style-type: none"> <li>Touch [Input].</li> <li>Touch the Clear key.</li> <li>Enter the port number (SSL) between 1 and 65535 using the 10-key pad.</li> </ol>

<Detail Settings: SMTP Authentication>

Functions	<ul style="list-style-type: none"> <li>To set whether or not to enable SMTP authentication.</li> </ul>
Use	<ul style="list-style-type: none"> <li>To use when conducting SMTP authentication.</li> </ul>
Setting/ Procedure	<ul style="list-style-type: none"> <li>The default setting is OFF.</li> </ul> <p style="text-align: center;">ON    "OFF"</p> <ul style="list-style-type: none"> <li>When set to "ON", enter the [User ID], [Password] and [Domain Name].</li> </ul>

<Detail Settings: POP Before SMTP Authentication>

Functions	<ul style="list-style-type: none"> <li>To set whether or not to enable the POP Before SMTP authentication.</li> </ul>
Use	<ul style="list-style-type: none"> <li>To use when conducting POP Before SMTP authentication.</li> </ul>
Setting/ Procedure	<ul style="list-style-type: none"> <li>The default setting is OFF.</li> </ul> <p style="text-align: center;">ON <span style="float: right;">"OFF"</span></p>

<Detail Settings: POP Before SMTP Time>

Functions	<ul style="list-style-type: none"> <li>To set the time necessary for POP Before SMTP authentication.</li> </ul>
Use	<ul style="list-style-type: none"> <li>To change the time necessary for POP Before SMTP authentication.</li> </ul>
Setting/ Procedure	<ol style="list-style-type: none"> <li>1. Touch [Input].</li> <li>2. Press the Clear key.</li> <li>3. Enter the time for POP Before SMTP between 0 and 60 using the 10-key pad.</li> </ol>

**(2) E-mail RX (POP)**

<E-mail RX (POP)>

Functions	<ul style="list-style-type: none"> <li>To set whether to enable or disable the e-mail reception setting.</li> </ul>
Use	<ul style="list-style-type: none"> <li>To disable the e-mail reception setting.</li> </ul>
Setting/ Procedure	<ul style="list-style-type: none"> <li>The default setting is ON.</li> </ul> <p style="text-align: center;">"ON" <span style="float: right;">OFF</span></p>

<POP Server Address>

Functions	<ul style="list-style-type: none"> <li>To set the POP server address.</li> </ul>
Use	<ul style="list-style-type: none"> <li>To enter the POP server address.</li> </ul>
Setting/ Procedure	<ol style="list-style-type: none"> <li>1. Touch [Host Address].</li> <li>2. Select [Input Host Name], [IPv4 Address Input] or [IPv6 Address Input], and enter the server address.</li> </ol>

<Connection Timeout>

Functions	<ul style="list-style-type: none"> <li>To set the timeout period for connection in receiving e-mail to POP server.</li> </ul>
Use	<ul style="list-style-type: none"> <li>To set the timeout period of connection in receiving e-mail to POP server.</li> </ul>
Setting/ Procedure	<ul style="list-style-type: none"> <li>Select the timeout period of connection using [-]/[+] keys.</li> </ul>

<SSL Setting>

Functions	<ul style="list-style-type: none"> <li>To set whether or not to use SSL when receiving an e-mail.</li> </ul>
Use	<ul style="list-style-type: none"> <li>To use when receiving an e-mail which used SSL.</li> </ul>
Setting/ Procedure	<ul style="list-style-type: none"> <li>The default setting is OFF.</li> </ul> <p style="text-align: center;">ON <span style="float: right;">"OFF"</span></p>

<Port No.>

Functions	<ul style="list-style-type: none"> <li>To set the port No. for transmitting with POP server.</li> </ul>
Use	<ul style="list-style-type: none"> <li>To enter the port No. for transmitting with POP server.</li> </ul>
Setting/ Procedure	<ol style="list-style-type: none"> <li>Touch [Input].</li> <li>Touch the Clear key.</li> <li>Enter the port No. between 1 and 65535 using the 10-key pad.</li> </ol>

<Port Number (SSL)>

Functions	<ul style="list-style-type: none"> <li>To set the port number when using SSL.</li> </ul>
Use	<ul style="list-style-type: none"> <li>To enter the port number when using SSL.</li> </ul>
Setting/ Procedure	<ol style="list-style-type: none"> <li>Touch [Input].</li> <li>Touch the Clear key.</li> <li>Enter the port number (SSL) between 1 and 65535 using the 10-key pad.</li> </ol>

<Login Name>

Functions	<ul style="list-style-type: none"> <li>To enter a login name used for POP server authentication.</li> </ul>
Use	
Setting/ Procedure	<ol style="list-style-type: none"> <li>Touch [Login Name].</li> <li>Enter a login name.</li> </ol>

<Password>

Functions	<ul style="list-style-type: none"> <li>To enter a login name used for POP server authentication.</li> </ul>
Use	
Setting/ Procedure	<ol style="list-style-type: none"> <li>Touch [Password].</li> <li>Enter a password.</li> </ol>

<APOP Authentication>

Functions	<ul style="list-style-type: none"> <li>To set whether to use APOP authentication.</li> </ul>
Use	<ul style="list-style-type: none"> <li>To use APOP authentication.</li> </ul>
Setting/ Procedure	<ul style="list-style-type: none"> <li>The default setting is OFF.</li> </ul> <p style="text-align: center;">ON <span style="margin-left: 200px;">"OFF"</span></p>

<Check for New Messages>

Functions	<ul style="list-style-type: none"> <li>To set whether to automatically check a POP server for new messages.</li> </ul>
Use	
Setting/ Procedure	<ul style="list-style-type: none"> <li>The default setting is Yes.</li> </ul> <p style="text-align: center;">"Yes" <span style="margin-left: 150px;">No</span></p>

<Polling Interval>

Functions	<ul style="list-style-type: none"> <li>To set a polling interval at which a POP server is checked for new messages.</li> </ul>
Use	
Setting/ Procedure	<ul style="list-style-type: none"> <li>The default setting is 15 minutes.</li> </ul> <p style="text-align: center;">1 to 60 minutes</p>

**(3) S/MIME Communication Settings**

Functions	<ul style="list-style-type: none"> <li>To set whether to activate S/MIME communication that provides encrypted E-mail transmission.</li> </ul>
Use	
Setting/ Procedure	<ul style="list-style-type: none"> <li>The default setting is OFF.</li> </ul> <p style="text-align: center;">ON <span style="margin-left: 200px;">"OFF"</span></p>

<Digital Signature>

Functions	<ul style="list-style-type: none"> <li>Set whether to add a digital signature to S/MIME messages.</li> </ul>
Use	
Setting/ Procedure	<ul style="list-style-type: none"> <li>The default setting is Do not add signature.</li> </ul> <p style="text-align: center;">"Do not add signature"    Always add signature    Select when sending</p>

<E-mail Text Encryption Method>

Functions	<ul style="list-style-type: none"> <li>To select an encryption method used for S/MIME E-mail text.</li> </ul>
Use	
Setting/ Procedure	<ul style="list-style-type: none"> <li>The default setting is 3DES.</li> </ul> <p style="text-align: center;">RC2-40 RC2-64 RC2-128 DES "3DES" AES-128 AES-192 AES-256</p>

<Print S/MIME Information>

Functions	<ul style="list-style-type: none"> <li>To select whether to print S/MIME information when sending and receiving E-mail.</li> </ul>
Use	
Setting/ Procedure	<ul style="list-style-type: none"> <li>The default setting is No.</li> </ul> <p style="text-align: center;">Yes <span style="margin-left: 200px;">"No"</span></p>

<Automatically Obtain Certificates>

Functions	<ul style="list-style-type: none"> <li>To set whether to automatically acquire a certificate when sending or receiving E-mail.</li> </ul>
Use	
Setting/ Procedure	<ul style="list-style-type: none"> <li>The default setting is No.</li> </ul> <p style="text-align: center;">Yes <span style="margin-left: 200px;">"No"</span></p>



<Discovery User Permissions>

Functions	<ul style="list-style-type: none"> <li>To set whether or not to enable the discovery authority user which is used for SNMP v3.</li> </ul>
Use	
Setting/ Procedure	<ul style="list-style-type: none"> <li>The default setting is ON.</li> </ul> <p style="text-align: center;">"ON" <span style="margin-left: 150px;">OFF</span></p>

<Discovery User Name Settings>

Functions	<ul style="list-style-type: none"> <li>To set the name of the discovery authority Users which is used for SNMP v3.</li> </ul>
Use	
Setting/ Procedure	<ol style="list-style-type: none"> <li>Touch [Discovery User Name].</li> <li>Enter the discovery user name (up to 32 characters) on the on-screen keyboard, and touch [OK].</li> </ol> <p><b>NOTE</b></p> <ul style="list-style-type: none"> <li><b>The user name same with the read user name or the write user name cannot be set.</b></li> </ul>

<Read User Name Settings>

Functions	<ul style="list-style-type: none"> <li>To set the read-only user name used for SNMP v3.</li> </ul>
Use	
Setting/ Procedure	<ol style="list-style-type: none"> <li>Touch [Read User Name].</li> <li>Enter the read user name (up to 32 characters) on the on-screen keyboard, and touch [OK].</li> </ol> <p><b>NOTE</b></p> <ul style="list-style-type: none"> <li><b>The user Name same with the discovery user name cannot be used.</b></li> </ul>

<Security Level>

Functions	<ul style="list-style-type: none"> <li>To set the security level of the read-only user used for SNMP v3.</li> </ul>
Use	<ul style="list-style-type: none"> <li>To use when changing the security level of the read-only user.</li> </ul> <p>OFF : No authentication will be conducted when the read-only user accesses.</p> <p>auth-password : Conducts authentication only for the authentication password when the read-only user accesses.</p> <p>auth-Password/privpassword : Conducts authentication by authentication password and privacy password when read-only User accesses.</p>
Setting/ Procedure	<ul style="list-style-type: none"> <li>The default setting is auth-password/privpassword.</li> </ul> <p style="text-align: center;">OFF <span style="margin-left: 50px;">auth-password</span> <span style="margin-left: 50px;">"auth-password/privpassword"</span></p>

<Password Setting>

Functions	<ul style="list-style-type: none"> <li>To set the Authentication password for the read-only User which is used for SNMP v3.</li> </ul>
Use	
Setting/ Procedure	<ol style="list-style-type: none"> <li>Select a type of password.</li> <li>Enter the password (up to 32 characters) on the on-screen keyboard, and touch [OK].</li> </ol>



<Write User Name Settings>

Functions	<ul style="list-style-type: none"> <li>To set the name of the reading/writing authority user which is used for SNMP v3.</li> </ul>
Use	
Setting/ Procedure	<ol style="list-style-type: none"> <li>Touch [Write User Name].</li> <li>Enter the write user name (up to 32 characters) on the on-screen keyboard, and touch [OK].</li> </ol> <p><b>NOTE</b></p> <ul style="list-style-type: none"> <li>The user name same with the discovery use name cannot be used.</li> </ul>

<Security Level>

Functions	<ul style="list-style-type: none"> <li>To set the security level for the reading/writing authority user which is used for SNMP v3.</li> </ul>
Use	<ul style="list-style-type: none"> <li>To use for changing the security level of the reading/writing authority user.</li> </ul> <p>OFF : Authentication will not be conducted when reading/writing authority user accesses.</p> <p>auth-password : Conducts authentication only with authentication password when reading/writing authority user accesses.</p> <p>auth-password/privpassword : Conducts authentication by authentication password and privacy password when reading/writing authority user accesses.</p>
Setting/ Procedure	<ul style="list-style-type: none"> <li>The default setting is auth-password/privpassword.</li> </ul> <p>OFF auth-password "auth-password/privpassword"</p> <p><b>NOTE</b></p> <ul style="list-style-type: none"> <li>[Authentication OFF] cannot be selected when the following setting is set to "ON." [Administrator Settings] → [Security Settings] → [Enhanced Security Mode]</li> </ul>

I. AppleTalk Settings

- It will not be displayed when the following setting shows that authentication device is mounted.  
[Service Mode] → [Billing Setting] → [Management Function Choice]

(1) AppleTalk Settings

Functions	<ul style="list-style-type: none"> <li>To set whether to enable or disable the AppleTalk setting.</li> </ul>
Use	<ul style="list-style-type: none"> <li>To use AppleTalk setting.</li> </ul>
Setting/ Procedure	<ul style="list-style-type: none"> <li>The default setting is OFF.</li> </ul> <p>ON "OFF"</p>

(2) Printer Name

Functions	<ul style="list-style-type: none"> <li>To set the printer name displayed on the AppleTalk network.</li> </ul>
Use	<ul style="list-style-type: none"> <li>To set the printer name displayed on the AppleTalk network.</li> </ul>
Setting/ Procedure	<ol style="list-style-type: none"> <li>Touch [Printer Name].</li> <li>Enter the printer name (up to 31 characters) on the on-screen keyboard, and touch [OK].</li> </ol>

**(3) Zone Name**

Functions	<ul style="list-style-type: none"> <li>To set the zone name connected with AppleTalk network.</li> </ul>
Use	<ul style="list-style-type: none"> <li>To set the zone name connected with AppleTalk network.</li> </ul>
Setting/ Procedure	<ol style="list-style-type: none"> <li>Touch [Zone Name].</li> <li>Enter the zone name (up to 31 characters) on the on-screen keyboard, and touch [OK].</li> </ol>

**(4) Current Zone**

Functions	<ul style="list-style-type: none"> <li>To display the current zone on AppleTalk network.</li> </ul>
Use	<ul style="list-style-type: none"> <li>To check the current zone on the AppleTalk network.</li> </ul>

**J. Bonjour Setting**

**(1) Bonjour Setting**

Functions	<ul style="list-style-type: none"> <li>To set whether or not to use the Bonjour setting.</li> </ul>
Use	<ul style="list-style-type: none"> <li>To use when operating under the Bonjour service environment.</li> </ul>
Setting/ Procedure	<ul style="list-style-type: none"> <li>The default setting is ON.</li> </ul> <p style="text-align: center;">“ON” <span style="float: right;">OFF</span></p>

**(2) Bonjour Name**

Functions	<ul style="list-style-type: none"> <li>To set the Bonjour name.</li> </ul>
Use	<ul style="list-style-type: none"> <li>To set the name for identifying over the Bonjour network.</li> </ul>
Setting/ Procedure	<ol style="list-style-type: none"> <li>Touch [Bonjour Name].</li> <li>Enter the Bonjour name (up to 64 characters) on the on-screen keyboard, and touch [OK].</li> </ol>

**K. TCP Socket Settings**

**(1) TCP Socket**

Functions	<ul style="list-style-type: none"> <li>To set whether or not to set the TCP socket.</li> <li>To set the port number for TCP socket transmission.</li> </ul>
Use	<ul style="list-style-type: none"> <li>To use when using the application, etc. for TCP socket transmission.</li> <li>To be used when entering the port number used for TCP socket transmission.</li> </ul>
Setting/ Procedure	<ul style="list-style-type: none"> <li>The default setting is ON.</li> </ul> <p style="text-align: center;">“ON” <span style="float: right;">OFF</span></p> <p>&lt;Port Number&gt;</p> <ol style="list-style-type: none"> <li>Touch the Clear key.</li> <li>Enter the port number between 1 and 65535 using the 10-key pad.</li> </ol>

**(2) TCP Socket (ASCII Mode)**

Functions	<ul style="list-style-type: none"> <li>To set whether or not to set the TCP socket for ASCII mode.</li> <li>To set the port number which is used for TCP socket transmission by ASCII mode.</li> </ul>
Use	<ul style="list-style-type: none"> <li>To use when using the application, etc. for TCP socket transmission by ASCII mode.</li> <li>To use when entering the port number for TCP socket transmission by ASCII mode.</li> </ul>
Setting/ Procedure	<ul style="list-style-type: none"> <li>The default setting is ON.</li> </ul> <p style="text-align: center;">"ON" <span style="float: right;">OFF</span></p> <p>&lt;Port Number (ASCII Mode)&gt;</p> <ol style="list-style-type: none"> <li>Touch the Clear key.</li> <li>Enter the port number between 1 and 65535 using the 10-key pad.</li> </ol>

**L. Network Fax Setting**

**(1) Network Fax Function Settings**

- It will not be displayed on the screen when all items are set to "OFF" in the following settings.

[Service Mode] → [System 2] → [Network Fax Settings]

<IP Address Fax Function>

- Setting will be available only when [IP Address Fax] is set to "ON" in the following settings.

[Service Mode] → [System 2] → [Network Fax Settings]

Functions	<ul style="list-style-type: none"> <li>To set whether or not to use IP address fax function.</li> </ul>
Use	<ul style="list-style-type: none"> <li>To use IP address fax function.</li> </ul>
Setting/ Procedure	<ul style="list-style-type: none"> <li>The default setting is OFF.</li> </ul> <p style="text-align: center;">ON <span style="float: right;">"OFF"</span></p>

<Internet Fax Function>

- Setting will be available only when [Internet Fax] is set to "ON" in the following settings.

[Service Mode] → [System 2] → [Network Fax Settings]

Functions	<ul style="list-style-type: none"> <li>To set whether or not to use Internet fax function.</li> </ul>
Use	<ul style="list-style-type: none"> <li>To use Internet fax function.</li> </ul>
Setting/ Procedure	<ul style="list-style-type: none"> <li>The default setting is OFF.</li> </ul> <p style="text-align: center;">ON <span style="float: right;">"OFF"</span></p>

**(2) SMTP TX Settings**

Functions	<ul style="list-style-type: none"> <li>To set SMTP TX when network fax function is being used.</li> </ul>
Use	<ul style="list-style-type: none"> <li>To set SMTP TX port number and connecting time out period when network fax function is being used.</li> </ul>
Setting/ Procedure	<p>&lt;Port Number&gt;</p> <ol style="list-style-type: none"> <li>Touch [Input].</li> <li>Enter the port number between 1 and 65535 using the 10-key pad.</li> </ol> <p>&lt;Connection Timeout&gt;</p> <ol style="list-style-type: none"> <li>Touch [Input].</li> <li>Enter the connection timeout time between 5 and 1000 (sec.) using the 10-key pad.</li> </ol>

**(3) SMTP RX Settings**

Functions	<ul style="list-style-type: none"> <li>To set SMTP RX when network fax function is being used.</li> </ul>
Use	<ul style="list-style-type: none"> <li>To use SMTP RX function when network fax function is being used.</li> <li>To set SMTP RX port number and connecting time out period when network fax function is being used.</li> </ul>
Setting/ Procedure	<p>&lt;SMTP RX&gt;</p> <ul style="list-style-type: none"> <li>The default setting is ON.</li> </ul> <p style="text-align: center;">“ON” <span style="float: right;">OFF</span></p> <p>&lt;Port No.&gt;</p> <ol style="list-style-type: none"> <li>Touch [Input].</li> <li>Enter the port number between 1 and 65535 using the 10-key pad.</li> </ol> <p>&lt;Connection Timeout&gt;</p> <ol style="list-style-type: none"> <li>Touch [Input].</li> <li>Enter the connection timeout time between 5 and 1000 (sec.) using the 10-key pad.</li> </ol>

 **M. WebDAV Settings**

**(1) WebDAV Client Settings**

- This is displayed only when the function enhanced version 1 or later firmware is installed.

<WebDAV Client Setting>

Functions	<ul style="list-style-type: none"> <li>To set whether to use WebDAV Client Settings.</li> </ul>
Use	
Setting/ Procedure	<ul style="list-style-type: none"> <li>The default setting is ON.</li> </ul> <p style="text-align: center;">“ON” <span style="float: right;">OFF</span></p>

<WebDAV Client Settings: Proxy Server Address>

Functions	<ul style="list-style-type: none"> <li>To set the proxy server address.</li> </ul>
Use	<ul style="list-style-type: none"> <li>To enter the proxy server address.</li> </ul>
Setting/ Procedure	<ol style="list-style-type: none"> <li>Touch [Host Address].</li> <li>Select [Input Host Name], [IPv4 Address Input], or [IPv6 Address Input] and enter a host address.</li> </ol>

<WebDAV Client Settings: Proxy Server Port Number>

Functions	<ul style="list-style-type: none"> <li>To set the proxy server port number.</li> </ul>
Use	<ul style="list-style-type: none"> <li>To enter the proxy server port number.</li> </ul>
Setting/ Procedure	<ul style="list-style-type: none"> <li>Press the Clear key.</li> <li>Enter the proxy server port number between 1 and 65535 using the 10-key pad.</li> </ul>

<WebDAV Client Settings: User Name>

Functions	<ul style="list-style-type: none"> <li>To set the user name for WebDAV authentication.</li> </ul>
Use	
Setting/ Procedure	<ol style="list-style-type: none"> <li>Touch [User Name].</li> <li>Enter the user name on the on-screen keyboard, and touch [OK].</li> </ol>

<WebDAV Client Settings: Password>

Functions	<ul style="list-style-type: none"> <li>To set the password for WebDAV authentication.</li> </ul>
Use	
Setting/ Procedure	<ol style="list-style-type: none"> <li>Touch [Password].</li> <li>Enter the password on the on-screen keyboard, and touch [OK].</li> </ol>

<WebDAV Client Settings: Connection Timeout>

Functions	<ul style="list-style-type: none"> <li>To set the timeout period for connecting to WebDAV server.</li> </ul>
Use	<ul style="list-style-type: none"> <li>To change the timeout period for connecting.</li> </ul>
Setting/ Procedure	<ol style="list-style-type: none"> <li>Touch [Input].</li> <li>Press the Clear key.</li> <li>Enter the connecting timeout period between 5 and 300 using the 10-key pad.</li> </ol>

 **(2) WebDAV Server Settings**

- This is displayed only when the function enhanced version 2 or later firmware is installed.

<WebDAV Server Setting>

Functions	<ul style="list-style-type: none"> <li>To set whether to use WebDAV Server Settings.</li> </ul>
Use	
Setting/ Procedure	<ul style="list-style-type: none"> <li>The default setting is ON.</li> </ul> <p style="text-align: center;">“ON” <span style="margin-left: 200px;">OFF</span></p>

<WebDAV Server Settings: SSL Setting>

Functions	<ul style="list-style-type: none"> <li>To set whether to use SSL/TSL for communications when using the machine as WebDAV server.</li> </ul>
Use	
Setting/ Procedure	<ul style="list-style-type: none"> <li>The default setting is Non-SSL Only.</li> </ul> <p style="text-align: center;">“Non-SSL Only” <span style="margin-left: 100px;">SSL Only</span> <span style="margin-left: 100px;">SSL/Non-SSL</span></p>

<WebDAV Server Settings: Password Setting

Functions	<ul style="list-style-type: none"> <li>To set a password to access WebDAV server.</li> </ul>
Use	
Setting/ Procedure	<ol style="list-style-type: none"> <li>Touch [Password Setting].</li> <li>Enter a password with the keyboard on the screen, and touch [OK].</li> </ol> <ul style="list-style-type: none"> <li>Touching [Initial Password] can restore the default password setting. (Default password: sysadm)</li> </ul>

**N. Web Service Settings**

**(1) Web Service Common Settings**

<Web Service Common Settings: Friendly Name>

Functions	<ul style="list-style-type: none"> <li>To define a friendly name that is used when printing a job with Web Service function.</li> </ul>
Use	
Setting/ Procedure	<ol style="list-style-type: none"> <li>Touch [Friendly Name].</li> <li>Enter the friendly name (up to 62 characters) on the on-screen keyboard, and touch [OK].</li> </ol>

<Web Service Common Settings: SSL Setting>

Functions	<ul style="list-style-type: none"> <li>To set whether to use SSL when using Web Service function.</li> </ul>
Use	
Setting/ Procedure	<ul style="list-style-type: none"> <li>The default setting is OFF.</li> </ul> <p style="text-align: center;">ON <span style="float: right;">"OFF"</span></p>

**(2) Printer Settings**

<Printer Settings>

Functions	<ul style="list-style-type: none"> <li>To set whether to use this printer as a WS printer.</li> </ul>
Use	
Setting/ Procedure	<ul style="list-style-type: none"> <li>The default setting is OFF.</li> </ul> <p style="text-align: center;">ON <span style="float: right;">"OFF"</span></p>

<Printer Settings: Printer Name>

Functions	<ul style="list-style-type: none"> <li>To set the WS printer name.</li> </ul>
Use	
Setting/ Procedure	<ol style="list-style-type: none"> <li>Touch [Printer Name].</li> <li>Enter the friendly name (up to 63 characters) on the on-screen keyboard, and touch [OK].</li> </ol>

<Printer Settings: Printer Location>

Functions	<ul style="list-style-type: none"> <li>To set the WS printer location.</li> </ul>
Use	
Setting/ Procedure	<ol style="list-style-type: none"> <li>Touch [Printer Location].</li> <li>Enter the friendly name (up to 63 characters) on the on-screen keyboard, and touch [OK].</li> </ol>

<Printer Settings: Printer Information>

Functions	<ul style="list-style-type: none"> <li>To set the WS printer information.</li> </ul>
Use	
Setting/ Procedure	<ol style="list-style-type: none"> <li>Touch [Printer Information].</li> <li>Enter the friendly name (up to 63 characters) on the on-screen keyboard, and touch [OK].</li> </ol>

**(3) Scanner Settings**

<Scanner Settings>

Functions	<ul style="list-style-type: none"> <li>To set whether to use this machine as a WS scanner.</li> </ul>
Use	
Setting/ Procedure	<ul style="list-style-type: none"> <li>The default setting is ON.</li> </ul> <p style="text-align: center;">"ON" <span style="float: right;">OFF</span></p>

<Scanner Settings: Scanner Name>

Functions	<ul style="list-style-type: none"> <li>To set the WS scanner name.</li> </ul>
Use	
Setting/ Procedure	<ol style="list-style-type: none"> <li>Touch [Scanner Name].</li> <li>Enter the friendly name (up to 63 characters) on the on-screen keyboard, and touch [OK].</li> </ol>

<Scanner Settings: Scanner Location>

Functions	<ul style="list-style-type: none"> <li>To set the WS scanner location.</li> </ul>
Use	
Setting/ Procedure	<ol style="list-style-type: none"> <li>Touch [Scanner Location].</li> <li>Enter the friendly name (up to 63 characters) on the on-screen keyboard, and touch [OK].</li> </ol>

<Scanner Settings: Scanner Information>

Functions	<ul style="list-style-type: none"> <li>To set the WS scanner information.</li> </ul>
Use	
Setting/ Procedure	<ol style="list-style-type: none"> <li>Touch [Scanner Information].</li> <li>Enter the friendly name (up to 63 characters) on the on-screen keyboard, and touch [OK].</li> </ol>

<Scanner Settings: Connection Timeout>

Functions	<ul style="list-style-type: none"> <li>To set the timeout period for connection of WS scanner.</li> </ul>
Use	
Setting/ Procedure	<ol style="list-style-type: none"> <li>Press the Clear key.</li> <li>Enter the connecting timeout period between 30 and 300 using the 10-key pad.</li> </ol>

**O. Detail Settings**

**(1) Device Setting**

<MAC Address>

Functions	<ul style="list-style-type: none"> <li>To display the MAC address of the machine.</li> </ul>
Use	<ul style="list-style-type: none"> <li>To check the MAC address of the machine.</li> </ul>
Setting/ Procedure	<ul style="list-style-type: none"> <li>The address cannot be changed.</li> </ul>

<Network Speed>

Functions	<ul style="list-style-type: none"> <li>To set the network speed.</li> </ul>						
Use	<ul style="list-style-type: none"> <li>To set the specific network speed.</li> </ul>						
Setting/ Procedure	<ul style="list-style-type: none"> <li>The default setting is Auto.</li> </ul> <table style="margin-left: 40px;"> <tr> <td>“Auto”</td> <td>10Mbps Full Duplex</td> <td>10Mbps Half Duplex</td> </tr> <tr> <td>100Mbps Full Duplex</td> <td>100Mbps Half Duplex</td> <td>1Gbps Full Duplex</td> </tr> </table> <p><b>NOTE</b></p> <ul style="list-style-type: none"> <li><b>When Network speed setting is changed, turn off the main power switch and turn it on again more than 10 seconds after.</b></li> </ul>	“Auto”	10Mbps Full Duplex	10Mbps Half Duplex	100Mbps Full Duplex	100Mbps Half Duplex	1Gbps Full Duplex
“Auto”	10Mbps Full Duplex	10Mbps Half Duplex					
100Mbps Full Duplex	100Mbps Half Duplex	1Gbps Full Duplex					

**(2) Time Adjustment Setting**

Functions	<ul style="list-style-type: none"> <li>To set whether to enable or disable the NTP setting.</li> </ul>
Use	<ul style="list-style-type: none"> <li>To synchronize the time between the server and the client.</li> </ul>
Setting/ Procedure	<ul style="list-style-type: none"> <li>The default setting is OFF.</li> </ul> <p style="text-align: center;">ON <span style="float: right;">"OFF"</span></p>

<NTP Server Setting>

Functions	<ul style="list-style-type: none"> <li>To set the NTP server address.</li> </ul>
Use	<ul style="list-style-type: none"> <li>To enter the NTP server address.</li> </ul>
Setting/ Procedure	<p>&lt;Host Address&gt;</p> <ol style="list-style-type: none"> <li>Touch [Host Address].</li> <li>Select [IP Address Input], and enter the IP address.</li> <li>Select [Host name Input], and enter the host name.</li> </ol> <p>&lt;Port Number&gt;</p> <ol style="list-style-type: none"> <li>Touch the Clear key.</li> <li>Enter the port number between 1 and 65535 using the 10-key pad.</li> </ol>

**(3) Status Notification Setting**

- It will not be displayed when the following setting shows that authentication device is mounted.  
[Service Mode] → [Billing Setting] → [Management Function Choice]
- To notify status, notifications both by E-mail and by SNMP TRAP function can be set. For E-mail, up to ten IP addresses and one IPX address can be set. For SNMP TRAP function, up to five IP addresses and one IPX can be set.

<Register Notification Address (IP Address)>

Functions	<ul style="list-style-type: none"> <li>To set IP addresses to which machine status notifications are sent.</li> </ul>
Use	<ul style="list-style-type: none"> <li>Use this function when setting IP addresses to which machine status notifications are sent.</li> <li>Up to 5 addresses can be registered.</li> </ul>
Setting/ Procedure	<ol style="list-style-type: none"> <li>From IP address 1 to 5, select an IP address where settings are made.</li> <li>Touch [Host Address].</li> <li>Select [Input Host], [IPv4 Address Input] or [IPv6 Address Input] and enter a host address.</li> <li>Touch the Clear key and enter a port number within the range of 1 to 65535 using the 10-key pad.</li> <li>Touch [Community Name] and enter a community name.</li> <li>Touch [Notification Item] and set the items to be notified to [ON].</li> <li>Touch [OK] and finish the settings.</li> </ol>



## &lt;Register Notification Address (IPX Address)&gt;

Functions	<ul style="list-style-type: none"> <li>To set IPX addresses to which machine status notifications are sent.</li> </ul>
Use	<ul style="list-style-type: none"> <li>Use this function when setting IPX addresses to which machine status notifications are sent.</li> </ul>
Setting/ Procedure	<ol style="list-style-type: none"> <li>Touch [IPX Address].</li> <li>Touch [Network Address] or [Node Address] and enter an address.</li> <li>Touch [Community Name] and enter a community name.</li> <li>Touch [Notification Item] and set the items to be notified to [ON].</li> <li>Touch [OK] and finish the settings.</li> </ol>

## &lt;Register Notification Address (E-mail Address)&gt;

Functions	<ul style="list-style-type: none"> <li>To set E-mail addresses to which machine status notifications are sent.</li> </ul>
Use	<ul style="list-style-type: none"> <li>Use this function when setting E-mail addresses to which machine status notifications are sent.</li> <li>Up to 10 addresses can be registered.</li> </ul>
Setting/ Procedure	<ol style="list-style-type: none"> <li>Touch [Forward].</li> <li>From E-mail addresses 1 to 10, select an E-mail address where settings are made.</li> <li>Touch [Edit E-mail Address].</li> <li>Enter an E-mail address (up to 320 one-byte characters) using the keyboard on the screen and touch [OK].</li> <li>Touch [Notification Item] and set the items to be notified to [ON].</li> <li>Touch [OK] and finish the settings.</li> </ol>

**(4) Total Counter Notification Settings**

## &lt;Notification Schedule Setting&gt;

Functions	<ul style="list-style-type: none"> <li>To set the schedule for informing the total counter value.</li> </ul>
Use	<ul style="list-style-type: none"> <li>To use when informing the total counter value by e-mail regularly.</li> <li>Two different schedules can be set for reporting.</li> </ul>
Setting/ Procedure	<ol style="list-style-type: none"> <li>Touch [Schedule 1] or [Schedule 2].</li> <li>Select the reporting cycle from [Daily], [Weekly] or [Monthly].</li> <li>When selecting [Daily] for the reporting cycle, set the Interval of day(s).</li> <li>When selecting [Weekly] for the reporting cycle, set the Interval of week(s) and day of the Week.</li> <li>When selecting [Monthly] for the reporting cycle, set the Interval of month(s) and date of the month.</li> </ol>

## &lt;Notification Address Setting&gt;

Functions	<ul style="list-style-type: none"> <li>To set the e-mail address for reporting the total counter value.</li> </ul>
Use	<ul style="list-style-type: none"> <li>Up to three e-mail addresses can be set.</li> <li>It can be selected whether to apply the schedule of the [Set Schedule] to each address.</li> </ul>
Setting/ Procedure	<ol style="list-style-type: none"> <li>Touch [Address 1], [Address 2] or [Address 3].</li> <li>Touch [E-mail Address Edit].</li> <li>Enter the e-mail address (up to 320 one-byte characters) on the on-screen keyboard, and touch [OK].</li> <li>Touch [Set Schedule].</li> <li>Select ON/OFF for each schedule.</li> </ol>

<Model Name>

Functions	<ul style="list-style-type: none"> <li>To set the device name for identifying the copier when reporting the total counter.</li> </ul>
Use	
Setting/ Procedure	<ol style="list-style-type: none"> <li>Touch [Model Name].</li> <li>Enter the model name (up to 20 one-byte characters) on the on-screen keyboard, and touch [OK].</li> </ol>

<Send Now>

Functions	<ul style="list-style-type: none"> <li>To transfer the current total counter value to the set address.</li> </ul>
Use	

**(5) PING Confirmation**

Functions	<ul style="list-style-type: none"> <li>To set the TCP/IP network diagnosis by PING.</li> </ul>
Use	<ul style="list-style-type: none"> <li>To check the condition of TCP/IP network.</li> </ul>
Setting/ Procedure	<ol style="list-style-type: none"> <li>Touch [Host Address] for PING transmission.</li> <li>Select [Input Host Name], [IPv4 Address Input], or [IPv6 Address Input] and enter a host address.</li> <li>Touch [Check Connection] key to check the connection.</li> </ol>

**(6) SLP Setting**

Functions	<ul style="list-style-type: none"> <li>To set whether to use SLP or not. Device search will be available with TWAIN by setting SLP enable.</li> </ul>
Use	
Setting/ Procedure	<ul style="list-style-type: none"> <li>The default setting is Enable.</li> </ul> <p style="text-align: center;">"Enable" <span style="float: right;">Disable</span></p>

**(7) LPD Setting**

Functions	<ul style="list-style-type: none"> <li>To set whether to use LPD during printing or not.</li> </ul>
Use	
Setting/ Procedure	<ul style="list-style-type: none"> <li>The default setting is Enable.</li> </ul> <p style="text-align: center;">"Enable" <span style="float: right;">Disable</span></p>

**(8) Prefix/Suffix Setting**

<ON/OFF Setting>

Functions	<ul style="list-style-type: none"> <li>To set whether to add prefix or suffix to the address when calling or entering an address.</li> </ul>
Use	
Setting/ Procedure	<ul style="list-style-type: none"> <li>The default setting is OFF.</li> </ul> <p style="text-align: center;">ON <span style="float: right;">"OFF"</span></p>

<Prefix/Suffix Setting>

Functions	<ul style="list-style-type: none"> <li>To register or change the prefix or suffix.</li> <li>Eight types of prefix and suffix can be added. Prefix: Letters added to the top of the text (header part) Suffix: Letters added to the bottom of the text (footer part)</li> </ul>
Use	<ul style="list-style-type: none"> <li>To register or change the address displayed for prefix or suffix.</li> </ul>
Setting/ Procedure	<ul style="list-style-type: none"> <li>Available number to be registered as prefix is up to 20 characters.</li> <li>Available number to be registered as suffix is up to 64 characters.</li> </ul>

**(9) Action for Invalid Certificate**

Functions	<ul style="list-style-type: none"> <li>To set how to process the job when SSL certificate becomes invalid.</li> </ul>
Use	
Setting/ Procedure	<ul style="list-style-type: none"> <li>The default setting is Continue. "Continue" Delete the Job</li> </ul>

**8.6.6 Copier Settings**

**A. Auto Zoom (Platen)**

Functions	<ul style="list-style-type: none"> <li>To set whether to function the auto zoom when the tray is selected with document set on the original glass (excepting at automatic paper selection mode.)</li> </ul>
Use	<ul style="list-style-type: none"> <li>To function the auto zoom when the feed tray is selected.</li> </ul>
Setting/ Procedure	<ul style="list-style-type: none"> <li>The default setting is OFF. ON "OFF"</li> </ul>

**B. Auto Zoom (ADF)**

Functions	<ul style="list-style-type: none"> <li>To set whether to function the auto zoom when the feed tray is selected with document set on the ADF (excepting at automatic paper selection mode.)</li> </ul>
Use	<ul style="list-style-type: none"> <li>To function the auto zoom when the tray is selected.</li> </ul>
Setting/ Procedure	<ul style="list-style-type: none"> <li>The default setting is ON. "ON" OFF</li> </ul>

**C. Specify Default Tray when APS OFF**

Functions	<ul style="list-style-type: none"> <li>To set the tray to be used when APS is cancelled.</li> </ul>
Use	<ul style="list-style-type: none"> <li>To set the tray (tray 1) for the default setting when cancelling APS.</li> </ul>
Setting/ Procedure	<ul style="list-style-type: none"> <li>The default setting is Tray Before APS ON. "Tray Before APS ON" Default Tray</li> </ul>

**D. Select Tray for Insert Sheet**

Functions	<ul style="list-style-type: none"> <li>To select the initial value for the tray for the cover sheet paper.</li> </ul>
Use	
Setting/ Procedure	<ul style="list-style-type: none"> <li>The default setting is Tray 2.</li> </ul>

**E. Print Jobs During Copy Operation**

Functions	<ul style="list-style-type: none"> <li>To set whether to receive printing jobs for print data or fax data during copy operation.</li> </ul>
Use	<ul style="list-style-type: none"> <li>To restrict receiving printing jobs for print data or fax data during copy operation.                             <ul style="list-style-type: none"> <li>Accept : Receives the print data or fax data and print</li> <li>Receive Only : Print data or fax data will be printed when the copy operation is finished</li> </ul> </li> </ul>
Setting/ Procedure	<ul style="list-style-type: none"> <li>The default setting is Accept.</li> </ul> <p style="text-align: center;">"Accept" <span style="margin-left: 200px;">Receive Only</span></p>

**F. Automatic Image Rotation**

Functions	<ul style="list-style-type: none"> <li>Select whether or not the image is automatically rotated when the document and copy paper orientations are different.</li> </ul>
Use	<p>When Auto Paper / Auto Zoom / Reduce is set: If the "Auto" Paper setting, "Auto" Zoom setting or a Reduce setting is selected, the image is automatically rotated to fit the orientation of the paper.</p> <p>When Auto Paper / Auto Zoom is set : If the "Auto" Paper setting or "Auto" Zoom setting is selected, the image is automatically rotated to fit the orientation of the paper.</p> <p>When Auto Zoom / Reduce is set : If the "Auto" Zoom setting or a Reduce setting is selected, the image is automatically rotated to fit the orientation of the paper.</p> <p>When Auto Zoom is set : If the "Auto" Zoom setting is selected, the image is automatically rotated to fit the orientation of the paper.</p>
Setting/ Procedure	<ul style="list-style-type: none"> <li>The default setting is When Auto Paper / Auto Zoom is set.</li> </ul> <p>When Auto Paper / Auto Zoom / Reduce is set "When Auto Paper / Auto Zoom is set"</p> <p>When Auto Zoom / Reduce is set When Auto Zoom is set</p>

**8.6.7 Printer Settings**

**A. USB Timeout**

Functions	<ul style="list-style-type: none"> <li>To set a period of time that elapses before input and output timeouts of communication are activated.</li> </ul>
Use	<ul style="list-style-type: none"> <li>To set a period of time that elapses before input and output timeouts of communication are activated.</li> </ul>
Setting/ Procedure	<ul style="list-style-type: none"> <li>The default setting is 60 seconds for input and output timeouts.</li> </ul> <p style="text-align: center;">"60 seconds" (10 to 1000 seconds)</p>

**B. Network Timeout**

Functions	<ul style="list-style-type: none"> <li>To set a period of time that elapses before input and output timeouts of communication are activated.</li> </ul>
Use	<ul style="list-style-type: none"> <li>To set a longer time period when timeout happens under some network statuses.</li> </ul>
Setting/ Procedure	<ul style="list-style-type: none"> <li>The default setting is 60 seconds for input and output timeouts.</li> </ul> <p style="text-align: center;">"60 seconds" (10 to 1000 seconds)</p>

**C. Print XPS Errors**

Functions	<ul style="list-style-type: none"> <li>To set whether to print error information when an error occurs while printing a XPS file.</li> </ul>
Use	
Setting/ Procedure	<ul style="list-style-type: none"> <li>The default setting is Yes.</li> </ul> <p style="text-align: center;">"Yes" <span style="margin-left: 200px;">No</span></p>

**8.6.8 Fax Settings**

- Settings are available only when the optional fax kit (FK-502) is mounted.

**A. Header Information**

Functions	<ul style="list-style-type: none"> <li>To register the name of the sender and fax ID which will be printed when transmitting fax.</li> </ul>
Use	<ul style="list-style-type: none"> <li>To register or change the name of the sender and fax ID.</li> </ul>
Setting/ Procedure	<ol style="list-style-type: none"> <li>Touch [Sender] and enter the name of the sender (up to 30 characters) on the on-screen keyboard.</li> <li>Enter Sender Fax No. (up to 20 characters) using the 10-key pad and [+], [Space] displayed on the screen.</li> </ol>

**B. Header/Footer Position**

**(1) Header Position**

Functions	<ul style="list-style-type: none"> <li>To set the position to print the header when transmitting fax.</li> </ul>
Use	<ul style="list-style-type: none"> <li>To change the position to print the header.</li> </ul>
Setting/ Procedure	<ul style="list-style-type: none"> <li>The default setting is Outside Body Text.</li> </ul> <p style="text-align: center;">                 Inside Body Text      "Outside Body Text"      OFF             </p> <p><b>NOTE</b></p> <ul style="list-style-type: none"> <li><b>[Outside Body Text] cannot be selected for Internet Fax/IP Address Fax.</b></li> </ul>

**(2) Print Receiver's Name**

- It will not be displayed on the screen when [Fax Target] is set to "US" or "HK" in the following settings.  
 [Service Mode] → [System 1] → [Marketing Area]

Functions	<ul style="list-style-type: none"> <li>To set whether to print the information of TX destination (Registered name or Fax No.) when transmitting fax.</li> </ul>
Use	<ul style="list-style-type: none"> <li>To print information of TX destination. (Registered name or Fax No.)</li> </ul>
Setting/ Procedure	<ul style="list-style-type: none"> <li>The default setting is OFF.</li> </ul> <p style="text-align: center;">ON <span style="margin-left: 200px;">"OFF"</span></p>

**(3) Footer Position**

Functions	<ul style="list-style-type: none"> <li>To set whether to print the footer when transmitting fax.</li> </ul>
Use	<ul style="list-style-type: none"> <li>To print the footer when transmitting fax.</li> </ul>
Setting/ Procedure	<ul style="list-style-type: none"> <li>The default setting is OFF.</li> </ul> <p style="text-align: center;">                 Inside Body Text      Outside Body Text      "OFF"             </p> <p><b>NOTE</b></p> <ul style="list-style-type: none"> <li><b>[Outside Body Text] cannot be selected for the color mode of Internet Fax/IP Address Fax.</b></li> </ul>

**C. Line Parameter Setting**

**(1) Dialing Method**

Functions	<ul style="list-style-type: none"> <li>To set the dialing method.</li> </ul>
Use	<ul style="list-style-type: none"> <li>To change the dialing method.</li> <li>The displays are different depending on the country.</li> </ul>
Setting/ Procedure	<ul style="list-style-type: none"> <li>The default setting is PB.</li> </ul> <p style="text-align: center;">                 "PB"      10 pps             </p> <p><b>NOTE</b></p> <ul style="list-style-type: none"> <li><b>The displays are different depending on the country.</b></li> </ul>

**(2) Receive Mode**

- It will not be displayed when the following setting shows that management device 2 is mounted.  
 [Service Mode] → [Billing Setting] → [Management Function Choice]

Functions	<ul style="list-style-type: none"> <li>To set the fax reception mode.</li> </ul>
Use	<ul style="list-style-type: none"> <li>To change to manual reception when using the remote reception function, etc. when connected to the external telephone.</li> </ul>
Setting/ Procedure	<ul style="list-style-type: none"> <li>The default setting is Auto RX.</li> </ul> <p style="text-align: center;">                 "Auto RX"      Manual RX             </p>

**(3) Number of RX Call Rings**

Functions	<ul style="list-style-type: none"> <li>To set the number of times to receive call rings.</li> </ul>
Use	<ul style="list-style-type: none"> <li>To change the number of times of the fake ringback tone after it starts calling until it starts receiving.</li> </ul>
Setting/ Procedure	<ul style="list-style-type: none"> <li>The default setting is 2 X.</li> </ul> <p style="text-align: center;">                 "2 X" (0 to 15)             </p>

**(4) Number of Redials**

Functions	<ul style="list-style-type: none"> <li>To set the number of redials.</li> </ul>
Use	<ul style="list-style-type: none"> <li>To change the number of times to redial when the line is busy, etc.</li> <li>The line which can be set up is different depending on the country.</li> </ul>
Setting/ Procedure	<ul style="list-style-type: none"> <li>The default setting is 3 X.</li> </ul> <p style="text-align: center;">“3 X” (0 to 7)</p> <p><b>NOTE</b></p> <ul style="list-style-type: none"> <li><b>The line which can be set up is different depending on the country.</b></li> </ul>

**(5) Redial Interval**

Functions	<ul style="list-style-type: none"> <li>To set the interval for redialing.</li> </ul>
Use	<ul style="list-style-type: none"> <li>To change the interval for redialing.</li> </ul>
Setting/ Procedure	<ul style="list-style-type: none"> <li>The default setting is 3 min.</li> </ul> <p style="text-align: center;">“3 min” (1 to 15)</p>

**(6) Line Monitor Sound**

Functions	<ul style="list-style-type: none"> <li>To set whether to output the line monitor sound from the speaker or not.</li> </ul>
Use	
Setting/ Procedure	<ul style="list-style-type: none"> <li>The default setting is ON.</li> </ul> <p style="text-align: center;">“ON” <span style="margin-left: 150px;">OFF</span></p>

**(7) Line Monitor Sound Vol.**

Functions	<ul style="list-style-type: none"> <li>To set the volume of the speaker.</li> </ul>
Use	<ul style="list-style-type: none"> <li>To change the volume of the speaker.</li> </ul>
Setting/ Procedure	<ul style="list-style-type: none"> <li>Change the volume by touching the [Lower] or [Higher].</li> </ul>

**D. TX/RX Settings**

**(1) Duplex Print (RX)**

- It will not be displayed when [Print Separate Fax Pages] is set to “ON.”

Functions	<ul style="list-style-type: none"> <li>To set whether to carry out the duplex print for the received original when receiving fax.</li> </ul>
Use	<ul style="list-style-type: none"> <li>To carry out the duplex print for the received original.</li> </ul>
Setting/ Procedure	<ul style="list-style-type: none"> <li>The default setting is OFF.</li> </ul> <p style="text-align: center;">ON <span style="margin-left: 150px;">“OFF”</span></p>

**(2) Letter/Ledger over A4/A3**

Functions	<ul style="list-style-type: none"> <li>To set weather to use the inch paper priority when receiving fax.</li> </ul>
Use	<ul style="list-style-type: none"> <li>To use the inch paper priority when receiving fax.</li> </ul>
Setting/ Procedure	<p style="text-align: center;">ON <span style="margin-left: 150px;">OFF</span></p> <p><b>NOTE</b></p> <ul style="list-style-type: none"> <li><b>The default setting is different depending on the country.</b></li> </ul>

**(3) Print Paper Selection**

Functions	<ul style="list-style-type: none"> <li>To set the priority for paper feed tray when receiving fax.</li> </ul>
Use	<ul style="list-style-type: none"> <li>To change the priority for paper feed tray when receiving fax.                             <ul style="list-style-type: none"> <li>Auto select : Selected automatically</li> <li>Priority Size : Printed on size with priority. When the size is not set, it will be printed on the closest size.</li> <li>Fixed Size : Printed only on the fixed size.</li> </ul> </li> </ul>
Setting/ Procedure	<ul style="list-style-type: none"> <li>The default setting is Auto Select.</li> </ul> <p style="text-align: center;">                     “Auto Select”                      Fixed Size                      Priority Size                 </p>

**(4) Print Paper Size**

Functions	<ul style="list-style-type: none"> <li>To set the paper size to print the text when receiving fax.</li> </ul>
Use	<ul style="list-style-type: none"> <li>To change the paper size for printing the received text.</li> <li>The displays are different depending on the country.</li> <li>To make the setting of [Print Paper Size] enable, set [Tray Selection for RX Print] to [Auto].</li> </ul>
Setting/ Procedure	<ul style="list-style-type: none"> <li>The initial setting is A4.</li> </ul> <p style="text-align: center;">                     A3                                      B4                                      “A4”                 </p> <p><b>NOTE</b></p> <ul style="list-style-type: none"> <li>The displays are different depending on the country.</li> </ul>

**(5) Incorrect User Box No. Entry**

Functions	<ul style="list-style-type: none"> <li>To set the operation when the unregistered box number is entered.</li> </ul>
Use	<ul style="list-style-type: none"> <li>To change the operation when the unregistered box number is entered.</li> </ul>
Setting/ Procedure	<ul style="list-style-type: none"> <li>The default setting is Print.</li> </ul> <p style="text-align: center;">                     “Print”                      Show Error Message                      Auto Create User Box                 </p>

**(6) Tray Selection for RX Print**

Functions	<ul style="list-style-type: none"> <li>To select the paper tray to be fixed when printing the received text.</li> </ul>
Use	<ul style="list-style-type: none"> <li>To fix the paper tray when printing the received text.</li> </ul>
Setting/ Procedure	<ul style="list-style-type: none"> <li>The default setting is Auto.</li> <li>Items available for selection are different depending on the paper feed option mounted.</li> </ul> <p style="text-align: center;">                     “Auto”                      Tray 1                      Tray 2                      Tray 3                      Tray 4                 </p>

**(7) Min. Reduction for RX Print**

Functions	<ul style="list-style-type: none"> <li>To set the print magnification for received text.</li> </ul>
Use	<ul style="list-style-type: none"> <li>To change the print magnification for received text.</li> </ul>
Setting/ Procedure	<ul style="list-style-type: none"> <li>The default setting is 96.</li> </ul> <p style="text-align: center;">                     “96” (87 to 96, x1.0)                 </p>



**(8) Print Separate Fax Pages**

- It will not be displayed when [Duplex print (RX)] is set to “ON.”

Functions	<ul style="list-style-type: none"> <li>• To set whether to divide the original into pages when it is longer than the standard size.</li> </ul>
Use	<ul style="list-style-type: none"> <li>• To divide the original into pages when it is longer than the standard size.</li> </ul>
Setting/ Procedure	<ul style="list-style-type: none"> <li>• The default setting is OFF.</li> </ul> <p style="text-align: center;">ON <span style="float: right;">“OFF”</span></p>

**(9) File After Polling TX**

Functions	<ul style="list-style-type: none"> <li>• To set whether to delete the original which polling transmission has been completed.</li> </ul>
Use	<ul style="list-style-type: none"> <li>• For not deleting the original which polling transmission has been completed.</li> </ul>
Setting/ Procedure	<ul style="list-style-type: none"> <li>• The default setting is Delete.</li> </ul> <p style="text-align: center;">“Delete” <span style="float: right;">Save</span></p>

**(10) No. of Sets (RX)**

Functions	<ul style="list-style-type: none"> <li>• To set the number of copies to be printed with the received document.</li> </ul>
Use	<ul style="list-style-type: none"> <li>• To use when changing the number of copies to be printed with the received document.</li> </ul>
Setting/ Procedure	<ul style="list-style-type: none"> <li>• The default setting is 1 set.</li> </ul> <p style="text-align: center;">1 to 10 set.</p>

**E. Function Settings**

**(1) Function ON/OFF Setting**

<F-Code TX>

Functions	<ul style="list-style-type: none"> <li>• To set whether to use the F code transmission.</li> </ul>
Use	
Setting/ Procedure	<ul style="list-style-type: none"> <li>• The default setting is ON.</li> </ul> <p style="text-align: center;">“ON” <span style="float: right;">OFF</span></p> <p><b>NOTE</b></p> <ul style="list-style-type: none"> <li>• <b>When the setting is changed, turn off the main power switch and turn it on again more than 10 seconds after.</b></li> </ul>

<Relay RX>

- It will be displayed when the following setting is set to “ON.”  
 [Service Mode] → [FAX] → [System] → [Display Setting] → [Relay]

Functions	<ul style="list-style-type: none"> <li>• To set whether to use the relay RX function.</li> </ul>
Use	<ul style="list-style-type: none"> <li>• To use the machine as the relay delivery station during relay TX.</li> </ul>
Setting/ Procedure	<ul style="list-style-type: none"> <li>• The default setting is ON.</li> </ul> <p style="text-align: center;">“ON” <span style="float: right;">OFF</span></p>

<Relay Printing>

- It will be displayed when the following setting is set to “ON.”  
 [Service Mode] → [FAX] → [System] → [Display Setting] → [Relay]

Functions	<ul style="list-style-type: none"> <li>• To set whether to use the relay print function.</li> </ul>
Use	<ul style="list-style-type: none"> <li>• To print out the document that the machine relayed during relay TX.</li> <li>• The relay print will be output in the following case.                     <ol style="list-style-type: none"> <li>1. When the relay delivery completes appropriately.</li> <li>2. When the delivery job is cancelled halfway by turning OFF sub power switch.</li> <li>3. When the delivery job is cancelled due to redial over.</li> <li>4. When main power switch is turned OFF/ON during relay print error.</li> <li>5. When delivery job is deleted in user operation during redialing.</li> <li>6. When delivery job is deleted in user operation during relay delivery.</li> </ol> </li> </ul>
Setting/ Procedure	<ul style="list-style-type: none"> <li>• The default setting is OFF.</li> </ul> <p style="text-align: center;">ON <span style="float: right;">“OFF”</span></p>

<Destination Check Display Function>

Functions	<ul style="list-style-type: none"> <li>• To set whether or not to display the list of specified addresses when sending the fax.</li> </ul>
Use	<ul style="list-style-type: none"> <li>• To use when displaying and checking the list of specified addresses when sending the fax.</li> </ul>
Setting/ Procedure	<ul style="list-style-type: none"> <li>• The default setting is OFF.</li> </ul> <p style="text-align: center;">ON <span style="float: right;">“OFF”</span></p>

 <Confirm Address (TX)>

Functions	<ul style="list-style-type: none"> <li>• To set whether to use Confirm Address (the machine displays the screen where the user reenters the fax number for confirmation when the user faxes by entering the fax number directly with the keys).</li> </ul>
Use	<ul style="list-style-type: none"> <li>• To enable entering the fax number again to avoid faxing to a wrong recipient.</li> </ul>
Setting/ Procedure	<ul style="list-style-type: none"> <li>• The default setting is OFF.</li> </ul> <p style="text-align: center;">ON <span style="float: right;">“OFF”</span></p>

 <Confirm Address (Register)>

Functions	<ul style="list-style-type: none"> <li>• To set whether to use Confirm Address (the machine displays the screen where the user reenters the fax number for confirmation when the user faxes by entering the fax number directly with the keys).</li> </ul>
Use	<ul style="list-style-type: none"> <li>• To enable entering the fax number again to avoid faxing to a wrong recipient.</li> </ul>
Setting/ Procedure	<ul style="list-style-type: none"> <li>• The default setting is OFF.</li> </ul> <p style="text-align: center;">ON <span style="float: right;">“OFF”</span></p>

**(2) Memory RX Setting**

- It will be displayed only when the following setting is set to “ON.”  
[Service Mode] → [FAX] → [System] → [Display Setting] → [Compulsory Memory RX]
- It will not be displayed when [PC-FAX RX Setting], [Forward TX Setting] or [TSI User Box Setting] is set to “ON.”
- It will not be displayed when the following setting shows that vendor is mounted.  
[Service Mode] → [Billing Setting] → [Management Function Choice]

Functions	<ul style="list-style-type: none"> <li>• To set whether to use the forced memory RX function.</li> </ul>
Use	<ul style="list-style-type: none"> <li>• To store the received text in the hard disk without printing, and print it out when ordered.</li> </ul>
Setting/ Procedure	<ul style="list-style-type: none"> <li>• The default setting is NO.</li> <li>• Enter the password (up to 8 digits) for printing when set to [ON].</li> </ul>

**(3) Closed Network RX**

- It will be displayed when the following setting is set to “ON.”  
[Service Mode] → [FAX] → [System] → [Display Setting] → [Closed area RX]

Functions	<ul style="list-style-type: none"> <li>• To set whether to use the closed network function.</li> </ul>
Use	<ul style="list-style-type: none"> <li>• To receive data only from the device which password matches.</li> </ul>
Setting/ Procedure	<ul style="list-style-type: none"> <li>• The default setting is OFF.</li> <li>• When set to [ON], enter the password (up to 4 digits) to be used.</li> </ul>

**(4) Forward TX Setting**

- It will not be displayed when [PC-FAX RX Setting], [Memory RX] or [TSI User Box Setting] is set to “ON.”
- It will not be displayed when the following setting shows that Vendor or Authentication Device is mounted.  
[Service Mode] → [Billing Setting] → [Management Function Choice]

Functions	<ul style="list-style-type: none"> <li>• To set whether to use the forward fax function.</li> </ul>
Use	<ul style="list-style-type: none"> <li>• To forward the received text to the receiver which has been specified. Forward &amp; Print : Forward the received text, and print all out Forward &amp; Print (If TX Fails) : Forward the received text, and prints out only when fails to be forwarded</li> </ul>
Setting/ Procedure	<p>&lt;Forward TX Setting&gt;</p> <ul style="list-style-type: none"> <li>• The default setting is No.</li> <li>• When set to [Yes], set the address to forward to.</li> </ul>

**(5) Incomplete TX Hold**

- It will be displayed when the following setting is set to “ON.”  
[Service Mode] → [FAX] → [System] → [Display Setting] → [Re-Transmission]
- It will not be displayed when the following setting shows that Management Device 2 is mounted.  
[Service Mode] → [Billing Setting] → [Management Function Choice]

Functions	• To set whether to use incomplete TX hold function.
Use	• To re-send the data failed to be sent after a given time.
Setting/ Procedure	<ul style="list-style-type: none"> <li>• The default setting is No.</li> </ul> <p style="text-align: center;">Yes <span style="float: right;">“No”</span></p> <ul style="list-style-type: none"> <li>• When set to Yes, specify the Incomplete TX Hold Time.</li> </ul>

**(6) PC-Fax RX Setting**

- It will not be displayed when [Forward TX Setting], [Memory RX] or [TSI User Box Setting] is set to “ON.”

Functions	• To set whether to use the PC-FAX reception function.
Use	• To store the received text file in the box in the hard disk.
Setting/ Procedure	<ul style="list-style-type: none"> <li>• The default setting is Restrict.</li> </ul> <p style="text-align: center;">Allow <span style="float: right;">“Restrict”</span></p> <ul style="list-style-type: none"> <li>• When Allow is selected, make the settings of Receiving user box destination, Print ON/OFF, and Password check ON/OFF.</li> </ul>

**(7) TSI User Box Setting**

- It will not be displayed when [Forward TX Setting], [Memory RX] or [PC-Fax RX Setting] is set to “ON.”

Functions	<ul style="list-style-type: none"> <li>• To set whether to use TSI distribution or not.</li> <li>• To set setting method when there is no matched box at receiving.</li> </ul>
Use	<ul style="list-style-type: none"> <li>• To use TSI distribution.</li> <li>• To change setting method when there is no matched box at receiving.                             <ul style="list-style-type: none"> <li>Automatically Print : To print the received data.</li> <li>Memory RX Use Box : To store the received data in the forced memory receiving box.</li> </ul> </li> </ul>
Setting/ Procedure	<p>&lt;TSI User Box Setting&gt;</p> <ul style="list-style-type: none"> <li>• The default setting is No.</li> </ul> <p style="text-align: center;">Yes <span style="float: right;">“No”</span></p> <ul style="list-style-type: none"> <li>• Press [TSI User Box Registration] and register the distribution.</li> </ul> <p>&lt;Non-matched Box Setting&gt;</p> <ul style="list-style-type: none"> <li>• The default setting is Automatically Print.</li> </ul> <p style="text-align: center;">“Automatically Print” <span style="float: right;">Memory RX User Box</span></p>

**F. PBX Connection Setting**

Functions	<ul style="list-style-type: none"> <li>To set whether to use PBX connection setting or not.</li> </ul>
Use	<ul style="list-style-type: none"> <li>This will be used when the machine is connected to PBX line.</li> </ul>
Setting/ Procedure	<ul style="list-style-type: none"> <li>The default setting is No.</li> <li>When set to [Yes], enter the external number between 0 and 9999.</li> </ul>

**G. Report Settings**

**(1) Activity Report**

- It will not be displayed when the following setting shows that vendor or authentication device is mounted.  
 [Service Mode] → [Billing Setting] → [Management Function Choice]

Functions	<ul style="list-style-type: none"> <li>To set whether to print out the activity report or not, and also the timing for printing.</li> </ul>
Use	<ul style="list-style-type: none"> <li>To print out the activity report.</li> </ul>
Setting/ Procedure	<ul style="list-style-type: none"> <li>The default setting is ON.</li> </ul> <p style="text-align: center;">"ON" <span style="float: right;">OFF</span></p> <ul style="list-style-type: none"> <li>When this setting is set to ON, make the setting of Output Setting.</li> <li>The default setting is Every 100 Comm.</li> </ul> <p style="text-align: center;">Daily <span style="margin-left: 100px;">"Every 100 Comm."</span> <span style="float: right;">100/ Daily</span></p>

**(2) TX Result Report**

Functions	<ul style="list-style-type: none"> <li>To set whether to print out the TX report, and also the timing for printing.</li> </ul>
Use	<ul style="list-style-type: none"> <li>To print out the TX report.</li> </ul>
Setting/ Procedure	<ul style="list-style-type: none"> <li>The default setting is If TX Fails.</li> </ul> <p style="text-align: center;">ON <span style="margin-left: 100px;">"If TX Fails"</span> <span style="float: right;">OFF</span></p>

**(3) Sequential TX Report**

Functions	<ul style="list-style-type: none"> <li>To set whether to print out the sequential TX report or not.</li> </ul>
Use	<ul style="list-style-type: none"> <li>To print out the sequential TX report.</li> </ul>
Setting/ Procedure	<ul style="list-style-type: none"> <li>The default setting is ON.</li> </ul> <p style="text-align: center;">"ON" <span style="float: right;">OFF</span></p>

**(4) Timer Reservation TX Report**

Functions	<ul style="list-style-type: none"> <li>To set whether to print out the reservation TX or not.</li> </ul>
Use	<ul style="list-style-type: none"> <li>To print out the reservation TX.</li> </ul>
Setting/ Procedure	<ul style="list-style-type: none"> <li>The default setting is ON.</li> </ul> <p style="text-align: center;">"ON" <span style="float: right;">OFF</span></p>

**(5) Confidential RX Report**

Functions	• To set whether to print out the confidential RX report.
Use	• To print out the confidential RX report.
Setting/ Procedure	• The default setting is ON.  "ON" OFF

**(6) Bulletin TX Report**

Functions	• To set whether to print out the bulletin TX report or not.
Use	• To print out the bulletin TX report.
Setting/ Procedure	• The default setting is ON.  "ON" OFF

**(7) Relay TX Result Report**

- It will be displayed when the following setting is set to "ON."  
[Service Mode] → [FAX] → [System] → [Display Setting] → [Relay]

Functions	• To set whether to print out the Relay TX Result Report or not.
Use	• To print out the relay TX result report after the relay delivery is completed when the machine is used as the relay delivery station.
Setting/ Procedure	• The default setting is ON.  "ON" OFF

**(8) Relay Request Report**

- It will be displayed when the following setting is set to "ON."  
[Service Mode] → [FAX] → [System] → [Display Setting] → [Relay]

Functions	• To set whether to print out the Relay Request RX Report or not.
Use	• To print out the Relay request RX report during relay request RX when the machine is used as the relay delivery station.
Setting/ Procedure	• The default setting is ON.  "ON" OFF

**(9) PC-Fax TX Error Report**

Functions	• To set whether to print out the PC-Fax TX Error Report or not.
Use	• To print out the PC-Fax error report when TX error occurs during PC-Fax TX.
Setting/ Procedure	• The default setting is OFF.  ON "OFF"

**(10) Broadcast Result Report**

Functions	• To set the format to output the broadcast result report.
Use	• To print out the broadcast result report All Destinations : Outputs all reports after transmitting to all addresses Each Destination : Outputs a report after each transmission
Setting/ Procedure	• The default setting is All Destinations. "All Destinations" Each Destination

**(11) TX Result Report Check**

Functions	• To set whether to display the TX result report screen.
Use	• To display the TX result report screen.
Setting/ Procedure	• The default setting is OFF. ON "OFF"

**(12) Network Fax RX Error Report**

- Settings will be available when either [IP Address Fax] or [Internet Fax] is set to "ON" in the following settings.  
[Administrator Settings] → [Network Setting] → [Network Fax Setting] → [Network Fax Function Settings]

Functions	• To set whether to print RX error report when network fax function is being used.
Use	• To print the error report at unusual situation such as receiving the image data that cannot be processed.
Setting/ Procedure	• The default setting is OFF. ON "OFF"

**(13) MDN Message**

- Settings will be available only when [Internet Fax] is set to "ON" in the following settings.  
[Administrator Settings] → [Network Setting] → [Network Fax Setting] → [Network Fax Function Settings]

Functions	• To set whether to print message when receiving response message to MDN request when internet fax function is being used.
Use	
Setting/ Procedure	• The default setting is ON "ON" OFF

**(14) DSN Message**

- Settings will be available only when [Internet Fax] is set to "ON" in the following settings.  
[Administrator Settings] → [Network Setting] → [Network Fax Setting] → [Network Fax Function Settings]

Functions	• To set whether to print message when receiving response message to DSN request when network fax function is being used.
Use	
Setting/ Procedure	• The default setting is OFF. ON "OFF"

**(15) Print E-mail Message Body**

- Settings will be available only when [Internet Fax] is set to “ON” in the following settings.  
[Administrator Settings] → [Network Setting] → [Network Fax Setting] → [Network Fax Function Settings]

Functions	• To set whether to print mail text received normally as the report when internet fax function is being used.
Use	• To print the received mail text when printing the received image data.
Setting/ Procedure	• The default setting is ON.  “ON” <span style="float: right;">OFF</span>

**H. Job Settings List**

- It will not be displayed when the following setting shows that Vendor is mounted.  
[Service Mode] → [Billing Setting] → [Management Function Choice]  
(It will be displayed when the Key counter is mounted or when the following setting shows that switch No.33 is set to [01] at HEX assignment.  
[Service Mode] → [System 2] → [Software Switch Setting])

Functions	• The set value list of the fax set up into this machine can be printed.
Use	
Setting/ Procedure	1. Touch [Administrator Settings] → [Fax Setting] → [Job Settings List]. 2. Select the feed tray. 3. Select the simplex or duplex print, and touch the Start key.

**I. Multi Lines Settings**

- It will be displayed only when the optional fax multi line (ML-501) is mounted.

**(1) Line Parameter Setting**

<Dialing Method>

Functions	• To set the dial method for the expanded line.
Use	• To use when changing the dial method for the expanded line.
Setting/ Procedure	• The default setting is PB.  “PB” <span style="float: right;">10 pps</span>  <b>NOTE</b> • <b>The displays are different depending on the country.</b>

<Number of Rx Call Rings>

Functions	• To set the number of RX call rings for the expanded line.
Use	• To change the number of artificial ringback tones with expanded line when receiving calls until it starts receiving operation.
Setting/ Procedure	• The default setting is 2 X.  “2 X” (0 to 15)



<Line Monitor Sound>

Functions	<ul style="list-style-type: none"> <li>To set whether or not to output the line monitor sound of the expanded line from the speaker.</li> </ul>
Use	
Setting/ Procedure	<ul style="list-style-type: none"> <li>The default setting is ON.</li> </ul> <p style="text-align: center;">"ON" <span style="margin-left: 150px;">OFF</span></p>

**(2) Function Settings**

<PC-FAX TX Setting>

- This setting does not appear when "RX Only" is selected for [Multi Line Settings].

Functions	<ul style="list-style-type: none"> <li>To set the number of the line used for PC-FAX transmission.</li> </ul>
Use	<ul style="list-style-type: none"> <li>To use when specifying the line to be used for PC-FAX transmission when using the expanded line.</li> </ul>
Setting/ Procedure	<ul style="list-style-type: none"> <li>The default setting is No Selection.</li> </ul> <p style="text-align: center;">"No Selection" <span style="margin-left: 100px;">Line 1</span> <span style="margin-left: 100px;">Line 2</span></p>

**(3) Multi Lines Setting**

Functions	<ul style="list-style-type: none"> <li>To set the system for using each line when using more than one line.</li> </ul>
Use	<ul style="list-style-type: none"> <li>To use when setting the system for using each line when using more than one line.</li> </ul>
Setting/ Procedure	<p>&lt;Multi Line Usage&gt;</p> <ul style="list-style-type: none"> <li>When selecting [Normal], perform the transmission setting for Line 2.</li> </ul> <p>&lt;Line 2 Setting&gt;</p> <ul style="list-style-type: none"> <li>The default setting is TX and RX.</li> </ul> <p style="text-align: center;">"TX and RX" <span style="margin-left: 100px;">RX Only</span> <span style="margin-left: 100px;">TX Only</span></p>

**(4) Sender Fax No.**

Functions	<ul style="list-style-type: none"> <li>To register the fax ID when using the additional line.</li> </ul>
Use	<ul style="list-style-type: none"> <li>To register the fax ID (for additional line).</li> </ul>
Setting/ Procedure	<ul style="list-style-type: none"> <li>Use 10-key pad or [+]/[space], enter the fax ID (up to 20 characters).</li> </ul>

**J. Network Fax Settings**

- It will be displayed only when either [IP Address Fax] or [Internet Fax] is set to “ON” in the following settings.  
[Administrator Settings] → [Network Settings] → [Network Fax Settings] → [Network Fax Function Settings]

**(1) Black Compression Level**

- It will be displayed only when either [IP Address Fax] or [Internet Fax] is set to “ON” in the following settings.  
[Administrator Settings] → [Network Settings] → [Network Fax Settings] → [Network Fax Function Settings]

Functions	• To set black compression level at monochrome TX mode when network fax function is being used.
Use	• To change black compression level at monochrome TX mode.
Setting/ Procedure	• The default setting is MH.  “MH”                                      MR                                      MMR

**(2) Internet Fax Self Rx Ability**

- It will be displayed only when [Internet Fax] is set to “ON” in the following settings.  
[Administrator Settings] → [Network Settings] → [Network Fax Settings] → [Network Fax Function Settings]

Functions	• To set image data compression system, paper size and resolution, which can be received by the machine with internet fax.															
Use	• To limit the data acceptable with internet fax.															
Setting/ Procedure	• The following shows the options of each setting item. <table border="1" style="margin-left: 20px;"> <thead> <tr> <th>Compression Type</th> <th>Paper Size</th> <th>Resolution</th> </tr> </thead> <tbody> <tr> <td>“MMR”</td> <td>“A3”</td> <td>Ultra Fine</td> </tr> <tr> <td>“MR”</td> <td>“B4”</td> <td>Super Fine</td> </tr> <tr> <td>“MH”</td> <td>“A4”</td> <td>Fine</td> </tr> <tr> <td>—</td> <td>—</td> <td>Std.</td> </tr> </tbody> </table>	Compression Type	Paper Size	Resolution	“MMR”	“A3”	Ultra Fine	“MR”	“B4”	Super Fine	“MH”	“A4”	Fine	—	—	Std.
Compression Type	Paper Size	Resolution														
“MMR”	“A3”	Ultra Fine														
“MR”	“B4”	Super Fine														
“MH”	“A4”	Fine														
—	—	Std.														

**(3) I-Fax Advanced Settings**

- It will be displayed only when [Internet Fax] is set to “ON” in the following settings.  
 [Administrator Settings] → [Network Settings] → [Network Fax Settings] → [Network Fax Function Settings]

Functions	<ul style="list-style-type: none"> <li>To set advanced functions of internet fax.</li> </ul>															
Use	<p>MDN Request : To set whether to send MDN (Message Disposition Notification) request when transmitting through internet fax.</p> <p>DSN Request : To set whether to send DSN (Delivery Status Notification) request when transmitting through internet fax.</p> <p>MDN Response : To set whether to response for MDN request made by the other machine when receiving through internet fax.</p> <p>MDN/DSN Response Watch Time : To set the period to observe the response from the other machine when sending MDN/DSN request. In the case of time over, time out message is notified.</p> <p>Max Resolution : To set maximum resolution for reading, TX/RX and record when internet fax function is being used.</p> <p><b>NOTE</b></p> <ul style="list-style-type: none"> <li><b>Only MDN Request will be sent when both MDN Request and DSN Request are set to “ON.”</b></li> </ul>															
Setting/ Procedure	<ul style="list-style-type: none"> <li>Default settings are shown below.</li> </ul> <table style="width: 100%; border: none;"> <tr> <td style="width: 50%;">MDN Request</td> <td style="width: 20%;">: “ON”</td> <td style="width: 30%;">OFF</td> </tr> <tr> <td>DSN Request</td> <td>: ON</td> <td>“OFF”</td> </tr> <tr> <td>MDN Response</td> <td>: “ON”</td> <td>OFF</td> </tr> <tr> <td>MDN/DSN Response Watch Time</td> <td>: “24 hours” (1 to 99)</td> <td>OFF</td> </tr> <tr> <td>Max Resolution</td> <td>: 400 x 400</td> <td>“600 x 600”</td> </tr> </table>	MDN Request	: “ON”	OFF	DSN Request	: ON	“OFF”	MDN Response	: “ON”	OFF	MDN/DSN Response Watch Time	: “24 hours” (1 to 99)	OFF	Max Resolution	: 400 x 400	“600 x 600”
MDN Request	: “ON”	OFF														
DSN Request	: ON	“OFF”														
MDN Response	: “ON”	OFF														
MDN/DSN Response Watch Time	: “24 hours” (1 to 99)	OFF														
Max Resolution	: 400 x 400	“600 x 600”														

**8.6.9 System Connection**

**A. OpenAPI Settings**

**(1) Access Setting**

Functions	<ul style="list-style-type: none"> <li>To allow or restrict the access from other systems with OpenAPI when using Page Scope Data Administrator.</li> </ul>		
Use	<ul style="list-style-type: none"> <li>To restrict access from other systems with OpenAPI.</li> </ul>		
Setting/ Procedure	<ul style="list-style-type: none"> <li>The default setting is Allow.</li> </ul> <table style="width: 100%; border: none;"> <tr> <td style="width: 50%; text-align: center;">“Allow”</td> <td style="width: 50%; text-align: center;">Restrict</td> </tr> </table>	“Allow”	Restrict
“Allow”	Restrict		

**(2) Port Number**

Functions	<ul style="list-style-type: none"> <li>To set the access port for other systems with OpenAPI when using PageScope Data Administrator.</li> </ul>
Use	<ul style="list-style-type: none"> <li>To change the access port number for other systems with OpenAPI.</li> </ul>
Setting/ Procedure	<ol style="list-style-type: none"> <li>Select Port No. or Port Number (SSL), and touch [Input].</li> <li>Press the Clear key.</li> <li>Enter the port number between 1 and 65535 using the 10-key pad.</li> </ol>

**(3) SSL**

- It will be displayed when certificate is issued from PageScope Web Connection.

Functions	<ul style="list-style-type: none"> <li>• To set whether to encrypt access from other systems by SSL when using Page Scope Data Administrator.</li> </ul>
Use	<ul style="list-style-type: none"> <li>• To encrypt access by SSL from other systems using OpenAPI.</li> </ul>
Setting/ Procedure	<ul style="list-style-type: none"> <li>• The default setting is OFF.</li> </ul> <p style="text-align: center;">ON <span style="float: right;">"OFF"</span></p>

**(4) Authentication**

Functions	<ul style="list-style-type: none"> <li>• To set whether to authenticate access of other systems which uses OpenAPI when using PageScope Data Administrator.</li> </ul>
Use	<ul style="list-style-type: none"> <li>• To set authentication of the access from other systems using OpenAPI.</li> </ul>
Setting/ Procedure	<ul style="list-style-type: none"> <li>• The default setting is OFF.</li> </ul> <p style="text-align: center;">ON <span style="float: right;">"OFF"</span></p> <ul style="list-style-type: none"> <li>• When setting to [ON], enter the login name and the password to be set.</li> </ul>

**B. Call Remote Center**

- It will be displayed when the setup at the CS Remote Care center is complete.

Functions	<ul style="list-style-type: none"> <li>• To call the CS Remote Care center from the administrator, when the CS Remote Care setup is complete.</li> </ul>
Use	
Setting/ Procedure	<p>For details, see "CS Remote Care." See P.368</p>

**8.6.10 Security Settings**

**A. Administrator Password**

Functions	<ul style="list-style-type: none"> <li>• To set/change the administrator password.</li> </ul>
Use	<ul style="list-style-type: none"> <li>• To change the administrator password.</li> </ul>
Setting/ Procedure	<ul style="list-style-type: none"> <li>• Enter the administrator password on the on-screen keyboard.</li> </ul> <p style="margin-left: 40px;">Current Password : Enter the current administrator password New Password : Enter the new administrator password to be used Re-Input Password : Re-enter the new administrator password</p> <p><b>NOTE</b></p> <ul style="list-style-type: none"> <li>• When selecting Utility → [Administrator Settings] → [Security Setting] → [Security Details] leads to [Password Rules] being ON, the password with the same letters, the password which is same as the previous one and the password of less than eight digits cannot be changed.</li> </ul>

### B. User Box Admin. Setting

Functions	<ul style="list-style-type: none"> <li>To set whether to allow or restrict the box administrator to use the system.</li> </ul>
Use	<ul style="list-style-type: none"> <li>To allow the box administrator to use the system. The box administrator is the special administrator for box, who is allowed to browse contents in common box / individual box without the password.</li> </ul> <p><b>NOTE</b></p> <ul style="list-style-type: none"> <li><b>[Allow] cannot be set when the user authentication or account track is not carried out.</b></li> </ul>
Setting/ Procedure	<ul style="list-style-type: none"> <li>The default setting is Restrict.</li> </ul> <p style="text-align: center;">Allow <span style="margin-left: 150px;">"Restrict"</span></p> <p><b>NOTE</b></p> <ul style="list-style-type: none"> <li><b>[Allow] cannot be selected when user authentication and account track are not conducted.</b></li> <li><b>[Allow] cannot be selected when the following setting is set to "ON:"</b> <b>[Administrator Settings] → [Security Settings] → [Enhanced Security Mode]</b></li> <li>Set the password when setting to [Allow].</li> </ul> <p><b>NOTE</b></p> <ul style="list-style-type: none"> <li><b>When the following setting shows that [Password Rules] is set to "ON", the Password using only a single letter or the password same with the previous one, or the password with less than eight letters cannot be accepted.</b> <b>[Administrator Settings] → [Security Settings]</b></li> </ul>

### C. Administrator Security Levels

- It will not be displayed when the following setting shows that vendor or authentication device 1 is mounted.  
[Service Mode] → [Billing Setting] → [Management Function Choice]

Functions	<ul style="list-style-type: none"> <li>To set the level for administrator settings item open to the user.</li> </ul>
Use	<ul style="list-style-type: none"> <li>To make part of the administrator settings items open to the user.</li> </ul> <p style="margin-left: 20px;">Level 1 : [Power Save Setting], [Auto Magnification Selection (Platen)], [Auto Magnification Selection (ADF)], [Specify Default Tray when APS Off], and [Select Tray for Insert Sheet] are available to users.</p> <p style="margin-left: 20px;">Level 2 : [Power Save Setting], [Output Setting], [Date/Time Setting], [Daylight Savings Time Setting], [AE Level Adjustment], [Auto Magnification Selection (Platen)], [Auto Magnification Selection (ADF)], [Specify Default Tray when APS Off], [Select Tray for Insert Sheet], and [Print Jobs During Copy Operation] are available to users.</p> <p style="margin-left: 20px;">Prohibit : Not to allow the user to set neither Level 1 nor Level 2</p>
Setting/ Procedure	<ul style="list-style-type: none"> <li>The default setting is Prohibit.</li> </ul> <p style="text-align: center;">Level 1 <span style="margin-left: 100px;">Level 2</span> <span style="margin-left: 100px;">"Prohibit"</span></p>

**D. Security Details**

**(1) Password Rules**

Functions	<ul style="list-style-type: none"> <li>To set whether to apply the password rules.</li> </ul>
Use	<ul style="list-style-type: none"> <li>To apply the password rule to enhance security.</li> <li>Passwords to be covered: CE password, administrator password, user box password, user password, account track password, passwords for confidential documents.</li> <li>Details of the password rules:                      Password except user password, user box password shall be 8 digits of one-bite alphanumeric characters. (Case-sensitive)                      User password shall be 8 digits of one-bite alphanumeric characters. (Case-sensitive)                      User box password shall be 8 digits of one-bite alphanumeric characters.                      Password with only the same letter is prohibited.                      Password same with the one prior to change is prohibited.</li> </ul> <p>When the password rule is set to [ON], the password cannot be changed or registered unless it follows the above conditions.</p>
Setting/ Procedure	<ul style="list-style-type: none"> <li>The default setting is OFF.</li> </ul> <p style="text-align: center;">ON <span style="margin-left: 100px;">"OFF"</span></p> <p><b>NOTE</b></p> <ul style="list-style-type: none"> <li>[OFF] cannot be selected when the following setting is set to "ON."                      [Administrator Settings] → [Security Settings] → [Enhances Security Mode]</li> <li>[ON] cannot be selected when the following setting is set to "OFF."                      [Service Mode] → [Enhanced Security] → [CE Authentication]                      [CE Authentication] will not be displayed and cannot be set to "OFF" when [Password Rules] is set to "ON."</li> </ul>

**(2) Prohibited Functions When Authentication Error**

Functions	<ul style="list-style-type: none"> <li>To set the function for prohibiting authentication operation in order to prevent the unauthorized access.</li> </ul>						
Use	<ul style="list-style-type: none"> <li>To use when setting the system to prohibit authentication failure when conducting authentication by password, etc.</li> <li>Authentications which are subjected to this function: CE authentication, administrator authentication, user+ accounts authentication, SNMP authentication, secure print authentication, user box authentication.</li> </ul> <p>Mode 1 : When failed to authenticate, authentication operation (entering the password) will be prohibited for a certain period of time.</p> <p>Mode 2 : When failed to authenticate, authentication operation (entering the password) will be prohibited for a certain period of time.</p> <p>The number of times failure occurred will be counted, and when the number reaches to the specified time, authentication will be prohibited and the access will be locked.</p> <p>When the access is locked, touch [Release] on the main body, or turn main power switch OFF/ON to cancel it.</p> <p>For CE authentication and administrator authentication, only turning main power switch OFF/ON will cancel it.</p> <p>When the machine goes into an access lock condition, release the lock in the following procedure.</p> <table border="1" data-bbox="252 655 955 1075"> <tr> <td data-bbox="252 655 456 810">                     user+ accounts authentication                      SNMP authentication                      secure print authentication                      user box authentication                 </td> <td data-bbox="456 655 955 810"> <ul style="list-style-type: none"> <li>Touch keys in the following order. [Administrator Settings] → [Security Setting] → [Security Details] → [Prohibited Functions When Authentication Error]. Then touch [Release].</li> </ul> </td> </tr> <tr> <td data-bbox="252 810 456 946">Administrator authentication</td> <td data-bbox="456 810 955 946"> <ul style="list-style-type: none"> <li>After the main power switch is turned OFF and ON, the access lock is released automatically after the lapse of a predetermined period of time.</li> <li>[Service Mode] → [Enhanced Security] → [Administrator unlocking]</li> </ul> </td> </tr> <tr> <td data-bbox="252 946 456 1075">CE authentication</td> <td data-bbox="456 946 955 1075"> <ul style="list-style-type: none"> <li>The lock release timer starts to operate by input the Stop → 0 → 9 → 3 → 1 → 7 in [Meter Count] → [Check Details] → [Coverage Rate] after the main power switch is turned OFF and On. When the timer reaches the time specified in this setting, the access lock is released.</li> </ul> </td> </tr> </table>	user+ accounts authentication SNMP authentication secure print authentication user box authentication	<ul style="list-style-type: none"> <li>Touch keys in the following order. [Administrator Settings] → [Security Setting] → [Security Details] → [Prohibited Functions When Authentication Error]. Then touch [Release].</li> </ul>	Administrator authentication	<ul style="list-style-type: none"> <li>After the main power switch is turned OFF and ON, the access lock is released automatically after the lapse of a predetermined period of time.</li> <li>[Service Mode] → [Enhanced Security] → [Administrator unlocking]</li> </ul>	CE authentication	<ul style="list-style-type: none"> <li>The lock release timer starts to operate by input the Stop → 0 → 9 → 3 → 1 → 7 in [Meter Count] → [Check Details] → [Coverage Rate] after the main power switch is turned OFF and On. When the timer reaches the time specified in this setting, the access lock is released.</li> </ul>
user+ accounts authentication SNMP authentication secure print authentication user box authentication	<ul style="list-style-type: none"> <li>Touch keys in the following order. [Administrator Settings] → [Security Setting] → [Security Details] → [Prohibited Functions When Authentication Error]. Then touch [Release].</li> </ul>						
Administrator authentication	<ul style="list-style-type: none"> <li>After the main power switch is turned OFF and ON, the access lock is released automatically after the lapse of a predetermined period of time.</li> <li>[Service Mode] → [Enhanced Security] → [Administrator unlocking]</li> </ul>						
CE authentication	<ul style="list-style-type: none"> <li>The lock release timer starts to operate by input the Stop → 0 → 9 → 3 → 1 → 7 in [Meter Count] → [Check Details] → [Coverage Rate] after the main power switch is turned OFF and On. When the timer reaches the time specified in this setting, the access lock is released.</li> </ul>						
Setting/ Procedure	<ul style="list-style-type: none"> <li>The default setting is Mode 1.</li> </ul> <p style="text-align: center;">"Mode 1" <span style="margin-left: 200px;">Mode 2</span></p> <p><b>NOTE</b></p> <ul style="list-style-type: none"> <li><b>[Mode1] cannot be selected when the following setting is set to "ON."</b> [Administrator Settings] → [Security Setting] → [Enhanced Security Mode]</li> <li><b>Only the number of times for trials up to the access lock can be changed.</b></li> <li>When [Mode 2] is selected, set the number of times where checks are made before access is locked.</li> <li>Touch [Release Time Settings] and set a period of time that elapses before access lock is released.</li> </ul>						

bizhub C353/C253/C203

Adjustment / Setting

**(3) Confidential Document Access Method**

Functions	<ul style="list-style-type: none"> <li>To display the status of the authentication system on the control panel for the confidential document access.</li> </ul>
Use	<ul style="list-style-type: none"> <li>It cannot be changed at the operator's option since it will automatically be set according to the [Prohibit Functions When Auth. Error] setting.</li> <li>It will be set to [Mode 1] when [Prohibit Functions When Auth. Error] is set to [Mode 1]. It will be set to [Mode 2] when [Prohibit Functions when Auth. Error] is set to [Mode 2].</li> </ul> <p style="margin-left: 40px;">Mode 1 : This mode is for authentication by confidential document ID and password. It displays the list of the corresponding confidential document to print them.</p> <p style="margin-left: 40px;">Mode 2 : This mode is for authentication by confidential document ID. It displays the list of the corresponding confidential document, and print them with authentication by password.</p> <p><b>NOTE</b></p> <ul style="list-style-type: none"> <li><b>[Mode1] cannot be selected when the following setting is set to "ON."</b> <b>[Administrator Settings] → [Security Setting] → [Enhanced Security Mode]</b></li> </ul>
Setting/ Procedure	<ul style="list-style-type: none"> <li>The default setting is Mode 1.</li> </ul> <p style="text-align: center;">"Mode 1" <span style="float: right;">Mode 2</span></p>

**(4) Manual Destination Input**

Functions	<ul style="list-style-type: none"> <li>To set whether to allow or prohibit to manually enter the destination address on the Destination Input screen.</li> </ul>
Use	<ul style="list-style-type: none"> <li>To prohibit entering the destination address manually.</li> </ul>
Setting/ Procedure	<ul style="list-style-type: none"> <li>The default setting is Allow.</li> </ul> <p style="text-align: center;">"Allow" <span style="float: right;">Restrict</span></p>

**(5) Print Data Capture**

Functions	<ul style="list-style-type: none"> <li>To set whether to allow or restrict capturing the print job data.</li> </ul>
Use	<ul style="list-style-type: none"> <li>To be used when carrying out [Service Mode] → [System 2] → [Data capture].</li> </ul>
Setting/ Procedure	<ul style="list-style-type: none"> <li>The default setting is Allow.</li> </ul> <p style="text-align: center;">"Allow" <span style="float: right;">Restrict</span></p> <p><b>NOTE</b></p> <ul style="list-style-type: none"> <li><b>[Allow] cannot be selected when the following setting is set to "ON."</b> <b>[Administrator Settings] → [Security Setting] → [Enhanced Security Mode]</b></li> </ul>

bizhub\_C353/C253/C203

Adjustment / Setting



**(6) Audit Log Settings**

- It will be displayed when the following setting shows that switch No.42 is set to [01] at HEX assignment.  
[Service Mode] → [System 2] → [Software Switch Setting]

Functions	<ul style="list-style-type: none"> <li>Selects whether to keep logs of operations and access made by users and service engineers.</li> <li>To set whether to overwrite existing logs.</li> </ul>
Use	<ul style="list-style-type: none"> <li>To ensure security, this settings is used to keep logs of operations and access including security settings changes, authentication, and job executions by users and service engineers.</li> <li>Audit logs are saved in HDD and NVRAM.</li> </ul>
Setting/ Procedure	<ul style="list-style-type: none"> <li>The default setting is No.</li> </ul> <p style="text-align: center;">Yes <span style="margin-left: 200px;">"No"</span></p> <p><b>NOTE</b></p> <ul style="list-style-type: none"> <li><b>After selecting "Yes", the main power switch must be turned OFF and ON so that the new setting takes effect.</b></li> <li><b>When ON is selected in [Administrator Settings] → [Security Settings] → [Enhanced Security Mode], this setting is automatically set to "Yes."</b></li> </ul> <p>&lt;Overwrite&gt;</p> <ul style="list-style-type: none"> <li>Set whether to allow or restrict overwriting existing logs when saving audit logs.</li> <li>The default setting is Restrict.</li> </ul> <p style="text-align: center;">Allow <span style="margin-left: 150px;">"Restrict"</span></p> <ul style="list-style-type: none"> <li>To erase audit logs, press [Erase Audit Log].</li> </ul>

**(7) Restrict Fax TX**

Functions	<ul style="list-style-type: none"> <li>To set whether or not to prohibit sending fax.</li> </ul>
Use	<ul style="list-style-type: none"> <li>To prohibit sending fax.</li> </ul>
Setting/ Procedure	<ul style="list-style-type: none"> <li>The default setting is OFF.</li> </ul> <p style="text-align: center;">ON <span style="margin-left: 150px;">"OFF"</span></p>

**(8) Hide Personal Information**

Functions	<ul style="list-style-type: none"> <li>Selects whether to display file names and destinations in job logs.</li> </ul>
Use	<ul style="list-style-type: none"> <li>Not to display file names and destinations that appears on job logs for security protection purpose.</li> </ul>
Setting/ Procedure	<ul style="list-style-type: none"> <li>The default setting is OFF.</li> </ul> <p style="text-align: center;">ON <span style="margin-left: 150px;">"OFF"</span></p>

**(9) Display Activity Log**

Functions	<ul style="list-style-type: none"> <li>Selects whether to display communication logs for scan/fax transmission.</li> </ul>
Use	
Setting/ Procedure	<ul style="list-style-type: none"> <li>The default setting is ON.</li> </ul> <p style="text-align: center;">"ON" <span style="margin-left: 150px;">OFF</span></p>

**(10) Delete Job Log**

Functions	<ul style="list-style-type: none"> <li>Clear the all job logs.</li> </ul>
Use	
Setting/ Procedure	<ol style="list-style-type: none"> <li>Touch [Delete Job Log].</li> <li>Select [Yes] on the confirmation screen and touch [OK].</li> </ol>

**E. Enhanced Security Mode**

Use	<ul style="list-style-type: none"> <li>To set whether or not to enhance security.</li> </ul>
Setting/ Procedure	<ul style="list-style-type: none"> <li>To use when enhancing the security function at user's option.</li> <li>The following settings are necessary for setting the security enhancement "ON".                     <ul style="list-style-type: none"> <li>Administrator Password : Change it with the one which meets password rules.</li> <li>User Authentication : Set to "User Authentication (MFP)" or "User Authentication (External Server)".</li> <li>HDD Lock Password or Encryption word : Set the HDD lock password or encryption word with 20 characters. (Encryption word can be set only when SC-503 is mounted.)</li> <li>SSL Certificate : Register self-certificate for SSL communication from the PSWC.</li> <li>Image Controller Setting : Set to [Controller 0].</li> <li>CE Password : Change it with the one which meets password rules.</li> <li>Operation Ban release time: Set to 5 minutes or more.</li> <li>CE Authentication : Set to [ON].</li> <li>CS Remote Care : Conduct RAM clear, and cancel the setting.</li> <li>Management Function Choice : Set to "Unset."</li> </ul> </li> </ul>
Use	<ul style="list-style-type: none"> <li>The default setting is OFF.</li> </ul> <p style="text-align: center;">ON <span style="margin-left: 200px;">"OFF"</span></p>

**NOTE**

- Setting the Enhanced Security Mode "ON" will change the setting values for the following functions.**

Name of the function	Default setting	When Enhanced Security Mode is ON
Password Rules	OFF	ON (Cannot be changed)
Prohibit Functions When Auth. Error	Mode 1	Mode 2 (Cannot be changed) set to three times *Can change times (from once to three times)
User Name List	OFF	OFF (Cannot be change)
Print without Authentication	Restrict	Restrict (Cannot be changed)
User Box Admin. Setting	Restrict	Restrict (Cannot be changed)
Temporary Data Overwrite Setting	OFF	Mode 1 (Cannot be changed to Mode 2)
Secure Document Access Method	Mode 1	Mode 2 (Cannot be changed) *It will be changed according to "Prohibit Functions When Auth. Error".
SSL	OFF	ON (Cannot be changed)
FTP Server	ON	OFF (Cannot be changed)
SNMPv1/v2c	Read/Write allowed	Only "Read" is allowed (Cannot be changed)
SNMPv3 Write User Security Level	auth-password/ priv-password	Cannot be changed to disable authentication system

bizhub C353/C253/C203

Adjustment / Setting

Name of the function	Default setting	When Enhanced Security Mode is ON
Network Setting Clear (PageScope Web Connection)	Allow	Restrict
Administrator password change via network (Page-Scope Web Connection)	Allow	Restrict (Cannot be changed)
Registering and Changing Addresses by user	Allow	Restrict (Cannot be changed)
Public User Access	Restrict	Restrict (Cannot be changed)
Print Data Capture	Allowed	Prohibited (Cannot be changed)
Release Time Settings	5 min.	The lower limit of settable range is 5 minutes. (Cannot be set to less than 5 minutes)
Secure print user box preview	Image display/List display/document detail display	Only list display available before password authentication (Mode 2)
Internet ISW (Service Mode)	Disabled	Disabled (Cannot be changed)
Operation Ban release time (Service Mode)	5 min.	The lower limit of settable range is 5 minutes. (Cannot be set to less than 5 minutes)

**F. HDD Settings**

**(1) Check HDD Capacity**

Functions	<ul style="list-style-type: none"> <li>To display the used space capacity, total space capacity, and the remaining capacity of the hard disk.</li> </ul>
Use	<ul style="list-style-type: none"> <li>To check the capacity and the status of use of the hard disk.</li> </ul>

(2) Overwrite Temporary Data

- When the image becomes unnecessary, temporary data overwrite function will write meaningless data over all area where images are stored, and destroy the image data itself.

The structure of image data will be destroyed so that in case HDD is stolen, the remaining data included in the image data will not leak. Using the HDD lock password function or optional security kit (SC-503) along with this function will provide a high level of security which prevents images of great importance from leaking. It is recommended to use HDD lock password function or security kit (SC-503) along with this function for those who require high level of security.

Functions	<ul style="list-style-type: none"> <li>To set whether or not to use overwrite temporary data.</li> <li>To set overwriting method to use temporary data overwrite function.</li> </ul>
Use	<ul style="list-style-type: none"> <li>To use when making temporary data overwrite function valid.</li> <li>All data are temporarily written into HDD or memory during PC print, copier print, scanning and fax transmission. When the operation is complete, perform overwriting to the area data were once written in HDD or memory in order to enhance security.</li> <li>To change overwriting method to use temporary data overwrite function. <ul style="list-style-type: none"> <li>Mode 1: To overwrite 0x00 one time.</li> <li>Mode 2: Overwrite 0x00 → overwrite 0xff → overwrite 0x61 → validation</li> </ul> </li> <li>“Encryption Priority/Overwrite Priority” can be selected when the optional security kit SC-503 is mounted. <ul style="list-style-type: none"> <li>Encryption Priority : When the encryption word is set, the security level of the data will be enhanced before writing to HDD. When erasing data, they will all be converted into encryption data before overwritten. Therefore, overwriting will be executed with the value besides the value specified by the selected mode.</li> <li>Overwrite Priority : Standard encryption method will be applied to data written to HDD even when the encryption word is set, so overwriting and erasing will be performed without fail using the specified value in the selected mode. <ul style="list-style-type: none"> <li>It is used for performing the overwriting and erasing according to the HDD data erase standard.</li> </ul> </li> </ul> </li> </ul> <p><b>NOTE</b></p> <ul style="list-style-type: none"> <li><b>It is necessary to make HDD format when encryption priority/overwrite priority setting is changed.</b></li> </ul>
Setting/ Procedure	<ul style="list-style-type: none"> <li>The default setting is OFF.</li> </ul> <p style="text-align: center;">“OFF”                                  Mode 1                                  Mode 2</p> <p><b>NOTE</b></p> <ul style="list-style-type: none"> <li><b>[OFF] cannot be selected when the following setting is set to “ON.”</b> <b>[Administrator Settings] → [Security Setting] → [Enhanced Security Mode]</b></li> <li>The default setting is Encryption Priority. (Only when the optional security kit SC-503 is mounted.)</li> </ul> <p style="text-align: center;">“Encryption Priority”                                  Overwrite Priority</p>

### (3) Overwrite All Data

Functions	<ul style="list-style-type: none"> <li>To delete the whole data in the hard disk by overwriting.</li> <li>To initialize the area of use for the user stored in NVRAM.</li> </ul>
Use	<ul style="list-style-type: none"> <li>To use when disposing of the hard disk.</li> <li>Select the overwriting method from Mode 1 through 8.                             <ul style="list-style-type: none"> <li>Mode 1 : It overwrites 0x00 once.</li> <li>Mode 2 : Overwrites with random numbers → overwrites with random numbers → overwrites with 0x00</li> <li>Mode 3 : Overwrites with 0x00 → overwrites with 0xff → overwrites with random numbers → verifies</li> <li>Mode 4 : Overwrites with random numbers → overwrites with 0x00 → overwrites with 0xff</li> <li>Mode 5 : Overwrites with 0x00 → overwrites with 0xff → overwrites with 0x00 → overwrites with 0xff</li> <li>Mode 6 : Overwrites with 0x00 → overwrites with 0xff → overwrites with 0x00 → overwrites with 0xff → overwrites with 0x00 → overwrites with 0xff → overwrites with random numbers</li> <li>Mode 7 : Overwrites with 0x00 → overwrites with 0xff → overwrites with 0x00 → overwrites with 0xff → overwrites with 0x00 → overwrites with 0xff → overwrites with 0xaa</li> <li>Mode 8 : Overwrites with 0x00 → overwrites with 0xff → overwrites with 0x00 → overwrites with 0xff → overwrites with 0x00 → overwrites with 0xff → overwrites with 0xaa → verifies</li> </ul> </li> </ul>
Setting/ Procedure	<ol style="list-style-type: none"> <li>Touch [Overwrite All Data].</li> <li>Touch [Overwrite].</li> <li>Touch [Yes] on the check screen.</li> <li>Touch [YES] on the confirmation screen.</li> <li>Turn off the main power switch and turn it on again more than 10 seconds after.</li> </ol>

### (4) HDD Lock Password

Functions	<ul style="list-style-type: none"> <li>To set the lock password for the hard disk.</li> </ul>
Use	<ul style="list-style-type: none"> <li>To enter, change or delete the lock password for the hard disk.</li> </ul>
Setting/ Procedure	<ol style="list-style-type: none"> <li>Touch [HDD Lock Password].</li> <li>Enter the password (20 characters) on the on-screen keyboard, and touch [OK].</li> </ol> <p><b>NOTE</b></p> <ul style="list-style-type: none"> <li><b>Password using only a single letter is not acceptable.</b></li> <li><b>Don't forget the password. When the password is forgotten, the replacement of hard disk is needed.</b></li> </ul> <ol style="list-style-type: none"> <li>Re-enter the password to confirm.</li> <li>Turn OFF the main power switch and turn it ON again more than 10 seconds after.</li> </ol>

**(5) Format HDD**

Functions	<ul style="list-style-type: none"> <li>To conduct logical formatting of HDD.</li> </ul>
Use	<ul style="list-style-type: none"> <li>To initialize HDD.</li> </ul> <p><b>NOTE</b></p> <ul style="list-style-type: none"> <li>It is subject to logical formatting here, therefore if starting with physical formatting, follow as [Service Mode] → [State Confirmation] → [Memory/HDD Adj.] → [HDD Format].</li> </ul>
Setting/ Procedure	<ol style="list-style-type: none"> <li>Touch [HDD Formatting].</li> <li>Select [Yes] on the confirmation screen and touch [OK].</li> <li>Turn off the main power switch and turn it on again more than 10 seconds after.</li> </ol>

**(6) HDD Encryption Setting**

- It can be set only when the optional security kit (SC-503) is mounted.

Functions	<ul style="list-style-type: none"> <li>To set encryption key necessary to mount the optional security kit SC-503.</li> </ul>
Use	<ul style="list-style-type: none"> <li>To setup security kit SC-503.</li> <li>To re-set encrypting word due to exchange of NVRAM board or etc.</li> </ul> <p><b>NOTE</b></p> <ul style="list-style-type: none"> <li>This setting is available only when the optional security kit SC-503 is mounted.</li> <li>HDD formatting is required after this setting. Therefore it is necessary to retrieve certain data from HDD in advance. The following data will be lost after HDD formatting.</li> </ul> <ol style="list-style-type: none"> <li>① Address data</li> <li>② Authentication data : Authentication mode, user authentication setting, account track setting</li> <li>③ Box setting data : Box and text in the box, setting information of each box, box for fax</li> <li>④ Job history, fax transmission history</li> </ol>
Setting/ Procedure	<ol style="list-style-type: none"> <li>Press [HDD Encryption Setting].</li> <li>Enter encryption key (20 characters) with the keyboard on the operation panel and press [OK].</li> </ol> <p><b>NOTE</b></p> <ul style="list-style-type: none"> <li>Double-byte and identical characters are not acceptable.</li> </ul> <ol style="list-style-type: none"> <li>Turn off the main power switch and turn it on again more than 10 seconds after.</li> <li>Open [Administrator Settings] and conduct HDD formatting according to the instruction appeared on the panel.</li> <li>Turn off the main power switch and turn it on again more than 10 seconds after.</li> </ol>

**G. Function Management Setting**

**(1) Each Function Setting**

- It will be displayed only when the following setting shows that Vendor 2 or Management Device is mounted.  
[Service Mode] → [Billing Setting] → [Management Function Choice]

Functions	<ul style="list-style-type: none"> <li>• To set whether to use management function for each item of [Copy], [PC print], [Send data] and [Print others]. [Print others] is not displayed when vendor is connected.</li> <li>• [ON] for [Send Data] will not be displayed when the optional image controller (IC-409) is mounted.</li> </ul>
Use	<ul style="list-style-type: none"> <li>• To set whether to use Management function for each item of [Copy], [PC print], [Send data] and [Print others]. [Print others] is not displayed when Vendor is connected.</li> </ul>
Setting/ Procedure	<ul style="list-style-type: none"> <li>• The default setting is ON. "ON" OFF Prohibit</li> </ul>

**(2) Max Copy Set**

- It will be displayed only when the following setting shows that vendor is mounted.  
[Service Mode] → [Billing Setting] → [Management Function Choice]

Functions	<ul style="list-style-type: none"> <li>• To set the upper limit of the number of copy or PC print when management function has been set.</li> </ul>
Use	
Setting/ Procedure	<ul style="list-style-type: none"> <li>• The default setting is 999. 1 to "999"</li> </ul>

**(3) Network Function Settings**

Functions	<ul style="list-style-type: none"> <li>• To set whether to use network function or not when management function has been set.</li> </ul>
Use	<ul style="list-style-type: none"> <li>• Not to use the network function whose counter is difficult to be managed when management function has been set.</li> <li>• The following are target functions. PC-FAX transmission/Using the HDD TWAIN driver to view and retrieve documents in user boxes/Using PageScope Box Operator to view and retrieve documents in user boxes/Using PageScope Scan Direct to retrieve documents in user boxes/Using PageScope Job Spooler to view and retrieve documents in user boxes/Box operations using the PageScope Web Connection</li> </ul>
Setting/ Procedure	<ul style="list-style-type: none"> <li>• The default setting is ON. "ON" OFF</li> </ul> <p><b>NOTE</b></p> <ul style="list-style-type: none"> <li>• However, when the vendor or management device setting in the Service Mode is set, this setting is set to OFF. Exercise caution since it will stay in "OFF" setting even when "unset" is selected on vendor or management device setting in Service Mode later.</li> </ul>

**(4) Authentication Time Setting**

- It will be displayed only when the following setting shows that authentication device 1 is mounted.

[Service Mode] → [Billing Setting] → [Management Function Choice]

Functions	<ul style="list-style-type: none"> <li>• To set the authentication mode when authentication device is used.</li> </ul>
Use	<ul style="list-style-type: none"> <li>• To change the authentication mode when authentication device is used.                     <ul style="list-style-type: none"> <li>Keep Card : Authentication is available leaving the card in the given place when making authentication with the device.</li> <li>Touch and Go : Card is placed only when authentication is made with the device and if the card is left for a given time (Authentication reset time) the authentication setting is reset.</li> </ul> </li> <li>• When selecting “Touch and Go”, authentication reset is set after completing the job in [Authentication Time].</li> </ul>
Setting/ Procedure	<p>&lt;Authentication Method&gt;</p> <ul style="list-style-type: none"> <li>• The default setting is Touch and Go.</li> </ul> <p style="text-align: center;">Keep Card <span style="float: right;">“Touch and Go”</span></p> <p>&lt;Authentication Time&gt;</p> <ul style="list-style-type: none"> <li>• The default setting is 1 min.</li> </ul> <p style="text-align: center;">1 to 30 min.</p> <p>&lt;Authentication Log-out When Job is Completed&gt;</p> <ul style="list-style-type: none"> <li>• The default setting is Yes.</li> </ul> <p style="text-align: center;">“Yes” <span style="float: right;">No</span></p>

**H. Stamp Settings**

**(1) Apply Stamps**

Functions	<ul style="list-style-type: none"> <li>• Selects whether to add a stamp to documents when jobs are printed or fax/scanned data is sent.</li> </ul>
Use	
Setting/ Procedure	<ul style="list-style-type: none"> <li>• The each default setting is Do Not Apply.</li> </ul> <p style="text-align: center;">Apply <span style="float: right;">“Do Not Apply”</span></p> <ul style="list-style-type: none"> <li>• Touch “Apply” to make stamp settings independently for print and transmission modes.</li> </ul>

**(2) Delete Registered Stamp**

Functions	<ul style="list-style-type: none"> <li>• Deletes registered stamps, and copy protect/repeat stamps.</li> </ul>
Use	
Setting/ Procedure	<ol style="list-style-type: none"> <li>1. Touch [Delete Registered Stamp].</li> <li>2. Select [Stamp] or [Copy Protect/Stamp Repeat].</li> <li>3. Select [Yes] on the confirmation screen and touch [OK] to delete the registered stamps.</li> </ol>



### I. Image Log Transfer Settings

- It will be displayed when the following setting shows that switch No.63 is set to [01] at HEX assignment.  
[Service Mode] → [System 2] → [Software Switch Setting]

Functions	<ul style="list-style-type: none"> <li>Specifies whether to transfer the input or output image data to the server using whenever MFP inputs or outputs image data. Makes the settings of the WebDAV server or the FTP server where image data are transferred.</li> </ul>		
Use	<ul style="list-style-type: none"> <li>Use this settings to keep logs of input and output image data for security purpose.</li> </ul>		
Setting/ Procedure	<ul style="list-style-type: none"> <li>The each default setting is No.</li> </ul> <table style="width: 100%; text-align: center;"> <tr> <td>Yes</td> <td>"No"</td> </tr> </table> <ul style="list-style-type: none"> <li>When selecting [Yes], make the settings of the FTP server where data are transferred.</li> <li>Set the following item.</li> </ul> <p>&lt;WebDAV Server setting&gt;</p> <ul style="list-style-type: none"> <li>Host Name, File Path, User Name, Password, Port Number, Proxy, SSL Setting.</li> </ul> <p>&lt;FTP Server setting&gt;</p> <ul style="list-style-type: none"> <li>Host Name, File Path, User Name, Password, Port Number, PASV, and Proxy.</li> </ul> <p><b>NOTE</b></p> <ul style="list-style-type: none"> <li><b>When [Yes] is selected, a person who is registered as User cannot use Scan To FTP/WebDAV function.</b></li> </ul>	Yes	"No"
Yes	"No"		

### J. Driver Password Encryption Setting

Functions	<ul style="list-style-type: none"> <li>To set whether to use the factory default encryption word or user-defined one as a common key that encrypts a password used for a print job.</li> </ul>		
Use	<p>User-Defined : Sets an encryption word. Enter an encryption word of 20 letters.</p> <p>Use Factory Default: Uses the factory default encryption word (Undisclosed pre-defined encryption key).</p> <p><b>NOTE</b></p> <ul style="list-style-type: none"> <li><b>When selecting [User-Defined], set an encryption key being consisted of the same letters in the printer driver. If the encryption word set in the main body differs from the encryption key set in the printer driver, different encrypted passwords are created and printing cannot be made.</b></li> <li><b>The use of OpenAPI allows an encryption key to be obtained from the main body.</b></li> </ul>		
Setting/ Procedure	<ul style="list-style-type: none"> <li>The default setting is Use Factory Default.</li> </ul> <table style="width: 100%; text-align: center;"> <tr> <td>User-Defined</td> <td>"Use Factory Default"</td> </tr> </table>	User-Defined	"Use Factory Default"
User-Defined	"Use Factory Default"		

### 8.6.11 License Settings

- This is displayed only when the function enhanced version 2 or later firmware is installed.

#### A. Get Request Code

Functions	<ul style="list-style-type: none"> <li>To display and print a request code and serial number used to activate i-Option.</li> </ul>
Use	<ul style="list-style-type: none"> <li>Used to confirm the request code and serial number.</li> </ul>
Setting/ Procedure	<ol style="list-style-type: none"> <li>Touch [Get Request Code], and [Yes].</li> <li>A serial number and request code are issued.</li> <li>By touching [Print], the serial number and request code are printable.</li> </ol>

#### B. Install License

- This is displayed only when the additional memory included in the optional upgrade kit UK-201 is installed.

Functions	<ul style="list-style-type: none"> <li>To allow administrator to activate functions provided by i-Option.</li> </ul>
Use	<ul style="list-style-type: none"> <li>Used when administrator activates functions provided by i-Option.</li> <li>By selecting a desired function and entering the corresponding license code, the function can be activated.</li> <li>By making settings in [Service Mode] → [Billing Setting], CE can also activate functions provided by i-Option.</li> </ul>
Setting/ Procedure	<ol style="list-style-type: none"> <li>Touch [Install License].</li> <li>Touch [Select Function].</li> <li>Select i-Option function to be activated, and touch [Yes].</li> <li>Touch [OK].</li> <li>Touch [License Code].</li> <li>Enter the license code that was issued in the license management server using the key board on the control panel, and touch [OK].</li> <li>Touch [Install] key.</li> <li>Confirm the message, select [Yes], and touch [OK].</li> <li>Turn OFF and ON the main power switch.</li> </ol>

#### C. List of Enabled Functions

- This is displayed only when the additional memory included in the optional upgrade kit UK-201 is mounted.

Functions	<ul style="list-style-type: none"> <li>To display currently activated functions.</li> </ul>
Use	<ul style="list-style-type: none"> <li>Used to check the functions that are activated now.</li> </ul>

## 8.7 Banner Printing

Functions	<ul style="list-style-type: none"> <li>To shift to the banner printing mode.</li> </ul>
Use	<ul style="list-style-type: none"> <li>To use when printing on the long size paper.</li> </ul>
Setting/ Procedure	<ol style="list-style-type: none"> <li>Set the long size paper to the bypass tray.</li> <li>Touch [Banner Printing], and touch [ON].</li> <li>Send the job for the long paper print.</li> <li>Touch [Finish] to finish banner printing mode.</li> </ol> <p><b>NOTE</b></p> <ul style="list-style-type: none"> <li><b>Only PC print is available for the long paper print.</b></li> <li><b>Normal job cannot be accepted during banner printing mode.</b></li> </ul>

### 8.8 My Panel Settings

- This is displayed only when a registered user is logging in after user authentication. However, this is not displayed when both management device 2 and user authentication are used.

Functions	<ul style="list-style-type: none"> <li>• To make various settings about My Panel.</li> </ul>
Use	<ul style="list-style-type: none"> <li>• To customize My Panel screen for individual registered users.</li> <li>• Items that can be set are as follows: Language Setting, Measurement Unit Setting, Copier Settings, Scan/Fax Settings, Color Selection Setting, Main Menu Settings, and Initial Screen Setting</li> </ul>
Setting/ Procedure	<ol style="list-style-type: none"> <li>1. Touch [My Panel Settings].</li> <li>2. Touch a key that represents a desirable item and change its settings.</li> </ol> <p><b>NOTE</b></p> <ul style="list-style-type: none"> <li>• <b>Registering, editing, and deleting My Panel settings are allowed only when logging in as a registered user.</b></li> <li>• <b>When My Panel is not customized, the settings for MFP take effect in the three of the control panel settings, Language setting, Measurement unit setting, and Color selection setting.</b></li> <li>• <b>Depending on the functions provided by each MFP and the optional device configuration, not all My Panel settings may not take effect.</b></li> </ul>

Blank Page

bizhub C353/C253/C203

## 9. Adjustment item list



Replacement part/Service job			No	Replace paper feed roller	Replace separation roller assy	Change marketing area	Install LCT	Replace CCD unit	Replace mirror unit	Replace IU	Replace transfer belt unit	Replace PH unit	
Adjustment/setting items			No										
Machine	Printer Area	Print Positioning: Leading Edge	1									(3)	
		Print Positioning: Side Edge	2				○					(4)	
		Paper Feed Direction Adj.	3					(5)	(5)				
	Scan Area	Image position: Leading Edge	4										
		Image position: Side Edge	5					(4)					
		Cross Direction Adjustment	6					(3)					
		Feed Direction Adjustment	7						(4)				
	Org. Detecting Sensor Adj.	8				○							
	LD adjustment	LD lightness balance adjust.	9									(2)	
	Service Mode	Touch Panel Adjust		10									
State Confirmation		Memory/HDD	HDD R/W Check	11									
			HDD Format	12									
			Table Number	13									
Firmware Version		14											
System 1/2		Re-entry of setting values		15									
		Serial Number		16									
		Scan Calibration		17					(1)				
		Line Mag Setting		18					(2)				
Counter		Life	Counter Clear	19	○	○							
Image Process Adjustment	Gradation Adjust		20						○	○			
ADF	Read Pos Adj		21					(3)					
Enhanced Security	NVRAM Data Backup		22										
Re-entry of Utility settings			23										
Re-entry of Enhanced Security settings			24										
Parallel adjustment of scanner/mirrors carriage			25					(1)					
Positioning scanner unit			26					(2)					
Scanner motor belt adjustment			27										
Original glass moving unit height adjustment			28										
PH skew adjustment			29									(1)	
F/W upgrading			30										
Installation of original size sensor			31										
Remounting of NVRAM (MFP board)			32										
Replace transfer belt unit			33										

Adjustment / Setting



- This table shows the adjustment items that are required when a part of the machine has been replaced. Priority order, if applicable, during the adjustment procedures is indicated by the corresponding number in the parentheses.

No	Replace original size detection sensor	Wind scanner drive cables	Replace scanner motor	Replace scanner assy	Replace scanner home sensor	Replace original glass moving unit	Replace glass step sheet	Replace printer control board	Replace MFP board	Replace image processing board	Replace original glass	Replace IDC/registration sensor/F,R	Replace hard disk	Add key counter	Execute initialize	Execute add. option	Execute F/W update	Add fax board
1																		
2																		
3																		
4											(2)							
5					○						(1)							
6																		
7		(5)	(2)	(3)														
8	(3)																	
9																		
10															(6)			
11													(2)					
12													(1)					
13	(2)														(2)			
14																○	○	
15															(4)			
16															(3)			
17																		
18																		
19																		
20									(3)									
21		(4)		(2)		(2)	○											
22									(4)									
23															(1)			
24														○	(5)			
25		(2)																
26		(3)		(1)														
27		(1)	(1)															
28						(1)												
29																		
30								○	(2)	○								○
31	(1)																	
32									(1)									
33												○						

## 10. Service Mode

### 10.1 Service Mode function setting procedure

#### NOTE

- Ensure appropriate security for Service Mode function setting procedures. They should NEVER be shown to any unauthorized person not involved with service jobs.

#### A. Procedure

1. Press the Utility/Counter key.
2. Touch [Check Details] on meter count display.
3. Press the following keys in this order.; Stop → 0 → 0 → Stop → 0 → 1

#### NOTE

- When selecting [CE Authentication] under [Enhanced Security] available from Service Mode, authentication by CE password is necessary. Enter the 8 digits CE password, and touch [END]. (The initial setting for CE password is "92729272.")

- When the following setting is set to "ON", CE password authentication is necessary.

[Administrator Settings] → [Security Settings] → [Enhanced Security Mode]

- If a wrong CE password is entered, re-enter the right password. The machine will not enter Service Mode unless the CE password is entered correctly. To return to the Basic screen, turn OFF the sub power switch and turn it ON again. When the following setting is set to "Mode 2", operation will be prohibited since it indicates authentication failure by failing to enter the correct CE password within the specified number of times.

if the access lock is activated, the lock release timer starts to operate by input the Stop → 0 → 9 → 3 → 1 → 7 in [Meter Count] → [Check Details] → [Coverage Rate] after the main power switch is turned OFF and On. When the timer reaches the time specified in this setting, the access lock is released.

- The service code entered is displayed as "\*.\*."

4. The Service Mode menu will appear.

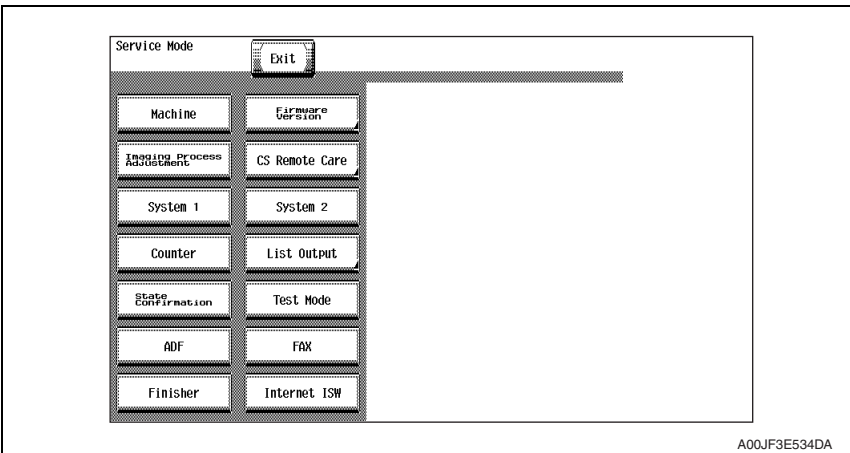

**NOTE**

- **Be sure to change the CE password from its default value.**
- **For the procedure to change the CE password, see the Enhanced Security.**  
[See P.436](#)

**B. Exiting**

- Touch the [Exit] key.

**C. Changing the setting value in Service Mode functions**

- Use the [+] / [-] key to enter or change the setting value.
- Use the 10-key pad to enter the setting value. (To change the setting value, first press the Clear key before making an entry.)



## 10.2 Service Mode function tree

\* The function tree is shown to comply with the format displayed on the screen.

\*1: Settings are available only when the optional fax kit (FK-502) is mounted.

\*2: It will be displayed only when the optional fax multi line (ML-501) is mounted.

\*3: It will be displayed only when the optional finisher (FS-519) or job separator (JS-505) is mounted.

\*4: It will be displayed only when the optional finisher (FS-519) is mounted.

\*5: It will be displayed only when the optional job separator (JS-505) is mounted.

\*6: It will be displayed only when the [Internet ISW Set] is set to "ON."

 \*7: It will be displayed only when the optional finisher (FS-609) is mounted.

Service Mode		Ref. Page	
Machine	Fusing Temperature	P.345	
	Fusing Transport Speed	P.346	
	Org. Size Detecting Sensor Adj.	P.346	
	Printer Area	Leading Edge Adjustment	P.347
		Centering	P.348
		Leading Edge Adj. (Duplex Side 2)	P.349
		Centering (Duplex 2nd Side)	P.350
		Paper Feed Direction Adj.	P.351
	Scan Area	Image Position: Leading Edge	P.352
		Image Position: Side Edge	P.353
		Cross Direction Adjustment	P.354
		Feed Direction Adjustment	P.355
	Printer Resist Loop	P.356	
	Color Registration Adjustment	Cyan	P.357
		Magenta	
		Yellow	
	Exhaust Fan Stop Delay		
LD adjustment	LD delay adjust.	P.358	
	LD lightness balance adjust.	P.359	
Manual Bypass Tray Adjustment		P.360	
Lead Edge Erase Adjustment		P.360	
Split Line Prior Detection		P.361	
Firmware Version		P.361	
Imaging Process Adjustment	Gradation Adjust	P.361	
	D Max Density	P.363	
	TCR Level Setting	P.363	
	Background Voltage Margin	P.364	
	Transfer Output Fine Adjustment	Primary transfer adj.	P.364
		Secondary transfer adj.	P.365

Service Mode		Ref. Page	
Imaging Process Adjustment	Stabilizer	Stabilization Only	P.365
		Initialize+Image Stabilization	P.366
	Thick Paper Density Adjustment		P.366
	TCR Toner Supply		P.366
	Monochrome Density Adjustment		P.367
	Dev. Bias Choice		P.367
CS Remote Care		P.368	
System 1	Marketing Area		P.388
	Tel/Fax Number		P.388
	Serial Number		P.389
	No Sleep		P.389
	Foolscap Size Setting		P.389
	Original Size Detection		P.389
	Install Date		P.390
	Initialization	Data Clear	P.390
		System Error Clear	P.390
	Trouble Isolation		P.391
	IU Life Setting		P.392
	Change Warm Up Time		P.393
	Machine State LED Setting		P.394
	System 2	HDD	
Image Controller Setting		P.395	
Option Board Status		P.396	
Consumable Life Reminder		P.396	
Unit Change		P.396	
Software Switch Setting		P.397	
Scan Calibration		P.397	
LCT Paper Size Setting		P.397	
Line Mag Setting		P.398	
Data Capture		P.399	
Split Line Detect. Setting		P.401	
Stamp		P.402	
Network Fax Settings		P.403	
Counter	Life		P.404
	Jam		P.405
	Service Call Counter		P.405
	Warning		P.405
	Maintenance		P.406
	Service Total		P.406
	Counter Of Each Mode		P.406
	Service Call History (Data)		P.406

bizhub\_C353/C253/C203

Adjustment / Setting

Service Mode		Ref. Page	
Counter	ADF Paper Pages	P.406	
	Paper Jam History	P.407	
	Fax Connection Error	P.407	
	Split Line Counter	P.407	
	Counter Reset	—	
List Output	Machine Management List	P.408	
	Adjustments List	P.408	
	Parameter List	P.408	
	Service Parameter	P.408	
	Protocol Trace	Last	P.408
		Error	
	Fax Setting List	P.408	
Fax Analysis List	P.408		
State Confirmation	Sensor Check	P.409	
	Table Number	P.422	
	Level History1	P.422	
	Level History2	P.422	
	Temp. & Humidity	P.422	
	CCD Check	P.423	
	Memory/HDD Adj.	Memory Check	P.423
		Compress / Decompression Check	P.423
		JPEG check	P.424
		Memory Bus Check	P.424
		Work Memory In/Out Check	P.424
		HDD Version Upgrade (LK)	P.424
		HDD Version Up	P.425
		HDD R/W Check	P.425
	HDD Format	P.425	
	Memory/HDD State	P.426	
	Color Regist	P.426	
IU Lot No.	P.426		
Adjustment Data List	P.426		
Test Mode	Gradation Pattern	P.427	
	Halftone Pattern	P.428	
	Lattice Pattern	P.428	
	Solid Pattern	P.429	
	Color Sample	P.429	
	8 Color Solid Pattern	P.430	
	CMM Pattern	P.430	
	Running Mode	P.430	
	Fax Test	P.431	





Service Mode		Ref. Page			
ADF	Original Stop Position		P.431		
	Registration Loop Adj.				
	Auto Stop Position Adjustment				
	Paper Passage				
	Sensor Check				
	Original Tray Width				
	Read Pos Adj				
	Feed Zoom	Orig. Feed Zoom Ad			
	Auto Adjust				
Scanning Light Adjustment					
FAX *1	Line 1 *1	Modem/NCU *1	P.431		
		NetWork *1			
		System *1			
		Fax File Format *1			
		Communication *1			
		List Output *1			
		Function Parameter *1			
		Initialization *1			
	Line 2 *2	Modem/NCU *2			
		NetWork *2			
		Communication *2			
		Initialization *2			
		CB-FN adjustment *4		P.431	
		Fold&Staple Pos. Adjustment *4			
Finisher Check *4					
Punch Regist Loop Size *4					
Punch Horizontal Position *4					
FN-X3 Adjustment *7	Center-Staple Position Adj. *7				
	Half-Fold Position Adj. *7				
Punch option setting					
Job Separator *5					
Internet ISW	Internet ISW Set	P.432			
	HTTP Setting *6	P.432			
	FTP Setting *6	P.433			
	Forwarding Access Setting *6	P.434			
	Download *6	P.435			



## 10.3 Date/Time Input mode

- This mode is used to set time-of-day and date.

### 10.3.1 Date & Time Setting mode screen

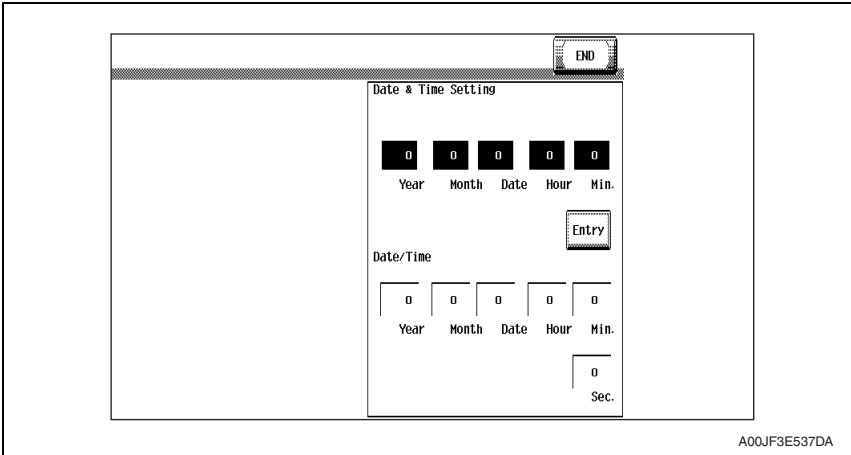

#### A. Date & Time Setting mode setting procedure

1. Call the Service Mode to the screen.
2. Press the following keys in this order.  
Stop → 1 → 1 → 4 → 4 → Clear
3. Enter year, month, day, hour, and minute, in that order, from 10-key pad.  
(Year 4 digits → Month 2 digits → Day 2 digits → Hour 2 digits → Minute 2 digits)

#### NOTE

- When setting the month, day, hour, or minute, enter “0” first if the data one digit.
4. Make sure that correct figures have been entered and then touch [Entry].
  5. Touch [END] to return to the Service Mode.

## 10.4 Machine

### 10.4.1 Fusing Temperature

Functions	<ul style="list-style-type: none"> <li>To adjust individually the temperature of the heating roller and the fusing pressure roller for each type of paper, thereby coping with varying fusing performance under changing environmental conditions.</li> </ul>																											
Use	<ul style="list-style-type: none"> <li>When fusing performance is poor, or wax streak or offset occurs when the type of paper is changed or environmental conditions change.</li> <li>Use when the curling of the paper due to the paper type or environmental change occurred, or when the paper jam, as well as stapling or folding position error occurred due to the curling of the paper.</li> <li>By setting the temperature higher (+), gloss of print can be improved.</li> <li>By setting the temperature lower (-), exit roller mark can be reduced.</li> </ul>																											
Adjustment Range	<table border="1"> <thead> <tr> <th>Paper type</th> <th>Setting range</th> <th>step</th> </tr> </thead> <tbody> <tr> <td>Plain Paper</td> <td>-20 °C to +5 °C</td> <td>5 °C</td> </tr> <tr> <td>OHP Film</td> <td>-20 °C to +5 °C</td> <td>5 °C</td> </tr> <tr> <td>Thick 1</td> <td>-20 °C to +5 °C</td> <td>5 °C</td> </tr> <tr> <td>Thick 2</td> <td>-20 °C to +5 °C</td> <td>5 °C</td> </tr> <tr> <td>Thick 3</td> <td>-20 °C to +5 °C</td> <td>5 °C</td> </tr> <tr> <td>Thick 4</td> <td>-20 °C to +5 °C</td> <td>5 °C</td> </tr> <tr> <td>Post.</td> <td>-20 °C to +5 °C</td> <td>5 °C</td> </tr> <tr> <td>Enve.</td> <td>-5 °C to +5 °C</td> <td>5 °C</td> </tr> </tbody> </table>	Paper type	Setting range	step	Plain Paper	-20 °C to +5 °C	5 °C	OHP Film	-20 °C to +5 °C	5 °C	Thick 1	-20 °C to +5 °C	5 °C	Thick 2	-20 °C to +5 °C	5 °C	Thick 3	-20 °C to +5 °C	5 °C	Thick 4	-20 °C to +5 °C	5 °C	Post.	-20 °C to +5 °C	5 °C	Enve.	-5 °C to +5 °C	5 °C
Paper type	Setting range	step																										
Plain Paper	-20 °C to +5 °C	5 °C																										
OHP Film	-20 °C to +5 °C	5 °C																										
Thick 1	-20 °C to +5 °C	5 °C																										
Thick 2	-20 °C to +5 °C	5 °C																										
Thick 3	-20 °C to +5 °C	5 °C																										
Thick 4	-20 °C to +5 °C	5 °C																										
Post.	-20 °C to +5 °C	5 °C																										
Enve.	-5 °C to +5 °C	5 °C																										
Adjustment Instructions	<p>If fusing performance is poor, increase the setting.                      If wax streaks occur, decrease the setting.                      If offset is poor, decrease the setting.                      If curling of the paper occurs, decrease the setting.</p>																											
Setting/ Procedure	<p><b>NOTE</b></p> <ul style="list-style-type: none"> <li><b>To adjust the fusing temperature, adjust on the heating side first. If the further adjustment is necessary, adjust on the pressure side.</b></li> </ul> <ol style="list-style-type: none"> <li>Call the Service Mode to the screen.</li> <li>Touch these keys in this order: [Machine] → [Fusing Temperature].</li> <li>Select the paper type and fusing roller type (Heater Roller or Pressure).</li> <li>Enter the new setting from the [+] / [-] key.</li> <li>Touch [END] to validate the adjustment value.</li> <li>Return to the basic screen.</li> <li>Output two or three test printing and check to see whether the image has any problem.</li> <li>Make the adjustment for each type of paper.</li> </ol>																											

### 10.4.2 Fusing Transport Speed

Functions	<ul style="list-style-type: none"> <li>To adjust the speed of the fusing drive motor so as to match the fusing speed with transport speed.</li> </ul>												
Use	<ul style="list-style-type: none"> <li>Brush effect or blurred image is evident as a result of changes in environmental conditions or degraded durability.</li> </ul>												
Variable Range	-20 to +20 (in 1 increments)												
Adjustment Instructions	<p>If brush effect is evident, vary the setting value and check for image. If a blurred image occurs, decrease the setting.</p>												
Setting/ Procedure	<ol style="list-style-type: none"> <li>Call the Service Mode to the screen.</li> <li>Touch these keys in this order: [Machine] → [Fusing Transport Speed].</li> <li>Select the transport speed, at which the brush effect or blurred image has occurred.</li> </ol> <p>&lt;bizhub C353&gt;</p> <table border="1"> <thead> <tr> <th>Transport speed</th> <th>Paper Setting</th> </tr> </thead> <tbody> <tr> <td>166.6 mm/s</td> <td>Plain paper: color/monochrome, OHF film</td> </tr> <tr> <td>55.5 mm/s</td> <td>Thick 1, Thick 2, Thick 3, Thick 4, envelope, postcard: monochrome/color</td> </tr> </tbody> </table> <p>&lt;bizhub C253/C203&gt;</p> <table border="1"> <thead> <tr> <th>Transport speed</th> <th>Paper Setting</th> </tr> </thead> <tbody> <tr> <td>111 mm/s</td> <td>Plain paper: color/monochrome, OHF film</td> </tr> <tr> <td>55.5 mm/s</td> <td>Thick 1, Thick 2, Thick 3, Thick 4, envelope, postcard: monochrome/color</td> </tr> </tbody> </table> <ol style="list-style-type: none"> <li>Enter the new setting from the 10-key pad.</li> <li>Touch [END] to validate the adjustment value.</li> <li>Check the copy image for any image problem.</li> </ol>	Transport speed	Paper Setting	166.6 mm/s	Plain paper: color/monochrome, OHF film	55.5 mm/s	Thick 1, Thick 2, Thick 3, Thick 4, envelope, postcard: monochrome/color	Transport speed	Paper Setting	111 mm/s	Plain paper: color/monochrome, OHF film	55.5 mm/s	Thick 1, Thick 2, Thick 3, Thick 4, envelope, postcard: monochrome/color
Transport speed	Paper Setting												
166.6 mm/s	Plain paper: color/monochrome, OHF film												
55.5 mm/s	Thick 1, Thick 2, Thick 3, Thick 4, envelope, postcard: monochrome/color												
Transport speed	Paper Setting												
111 mm/s	Plain paper: color/monochrome, OHF film												
55.5 mm/s	Thick 1, Thick 2, Thick 3, Thick 4, envelope, postcard: monochrome/color												

### 10.4.3 Org. Size Detecting Sensor Adj.

Functions	<ul style="list-style-type: none"> <li>To automatically adjust the original detection distance for the original size sensor.</li> <li>To display if the original size detection 2 Sensor is mounted.</li> </ul>
Use	<ul style="list-style-type: none"> <li>When the sensor is replaced with a new one.</li> <li>When an optional sensor has been added.</li> <li>When an erroneous original size detection is made.</li> <li>When the marketing area setting is changed.</li> </ul>
Adjustment Instructions	<p>If the adjustment has been successfully made, it completes the adjustment procedure. If the adjustment has turned out to be unsuccessful, check the optional original size sensors for correct installation and change the defective sensor or harness.</p>
Setting/ Procedure	<ol style="list-style-type: none"> <li>Place a blank sheet of A3 or 11 × 17 paper on the original glass and lower the original cover.</li> <li>Call the Service Mode to the screen.</li> <li>Touch these keys in this order: [Machine] → [Org. Size Detecting Sensor Adj.].</li> <li>Press the Start key.</li> </ol>

10.4.4 Printer Area

A. Leading Edge Adjustment

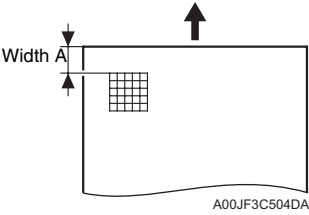
Functions	<ul style="list-style-type: none"> <li>To vary the print start position in the sub scan direction for each of different paper types in the manual bypass tray. (To adjust the timing where paper is sent out from the timing roller)</li> </ul>
Use	<ul style="list-style-type: none"> <li>The PH unit has been replaced.</li> <li>The paper type has been changed.</li> <li>The image on the copy deviates in the sub scan direction.</li> <li>A faint image occurs on the leading edge of the image.</li> <li>This setting can be made independently for plain paper, Thick 1, Thick 2, Thick 3, Thick 4, OHP transparencies, and envelopes.</li> </ul>
Adjustment Specification	<div style="display: flex; align-items: center;">  <div style="margin-left: 20px;"> <p>Width A on the test pattern produced should fall within the following range.</p> <p>Specifications: <math>4.2 \pm 0.5</math> mm Setting range: -3.0 mm to +3.0 mm (in 0.2 mm increments)</p> </div> </div>
Adjustment Instructions	<p>If width A is longer than the specifications, make the setting value smaller than the current one.</p> <p>If width A is shorter than the specifications, make the setting value greater than the current one.</p>
Setting/ Procedure	<ol style="list-style-type: none"> <li>Place A3 paper on the manual bypass tray.</li> <li>Call the Service Mode to the screen.</li> <li>Touch [Machine] → [Printer Area] → [Leading Edge Adjustment].</li> <li>Select the [Plain Paper].</li> <li>Press the Start key to let the machine produce a test pattern.</li> <li>Check the dimension of width A on the test pattern.</li> <li>If width A falls outside the specified range, change the setting using the [+] / [-] key.</li> <li>Press the Start key to let the machine produce a test pattern.</li> <li>Check the dimension of width A on the test pattern.</li> <li>If width A is outside the specified range, change the setting again and make a check again.</li> <li>If width A falls within the specified range, touch [END].</li> <li>Following the same procedure, adjust for Thick 1 to 3, OHP film, and Enve.</li> </ol>

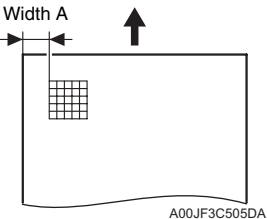

## B. Centering

Functions	<ul style="list-style-type: none"> <li>To vary the print start position in the main scan direction for each paper source.</li> </ul>
Use	<ul style="list-style-type: none"> <li>The PH Unit has been replaced.</li> <li>A paper feed unit has been added.</li> <li>The image on the copy deviates in the main scan direction.</li> </ul>
Adjustment Specification	<div style="display: flex; align-items: center;"> <div style="flex: 1;">  </div> <div style="flex: 2;"> <p>Width A on the test pattern produced should fall within the following range.</p> <p>Specifications: <math>3.0 \pm 0.5</math> mm            Setting range: -3.0 mm to +3.0 mm            (in 0.2 mm increments)</p> </div> </div>
Adjustment Instructions	<p>If width A is longer than the specifications, make the setting value smaller than the current one.</p> <p>If width A is shorter than the specifications, make the setting value greater than the current one.</p>
Setting/ Procedure	<ol style="list-style-type: none"> <li>1. Call the Service Mode to the screen.</li> <li>2. Touch [Machine] → [Printer Area] → [Centering].</li> <li>3. Select the paper source to be adjusted.</li> <li>4. Press the Start key to let the machine produce a test pattern.</li> <li>5. Check the dimension of width A on the test pattern.</li> <li>6. If width A falls outside the specified range, change the setting using the [+] / [-] key.</li> <li>7. Press the Start key to let the machine produce a test pattern.</li> <li>8. Check the dimension of width A on the test pattern.</li> <li>9. If width A is outside the specified range, change the setting again and make a check again.</li> <li>10. If width A falls within the specified range, touch [END].</li> <li>11. Following the same procedure, adjust for all other paper sources.          (Use A4 or <math>8\frac{1}{2} \times 11</math> plain paper for the bypass.)</li> </ol>

**C. Leading Edge Adj. (Duplex Side 2)**

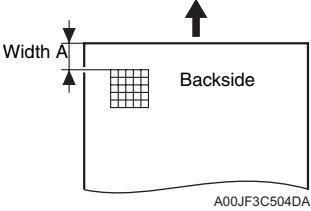
Functions	<ul style="list-style-type: none"> <li>For individual types of paper, this function allows the adjustment of the image write start position in the sub scan direction on the 2nd side of duplex printing.</li> </ul>
Use	<ul style="list-style-type: none"> <li>This adjustment is made when the image on the 2nd side of paper deviates from the original position in the sub scan direction.</li> <li>This adjustment can be made independently for each of plain paper, thick paper 1/ 1+, thick paper 2, and thick paper 3.</li> </ul>
Adjustment Specification	<div style="display: flex; align-items: center;"> <div style="flex: 1;">  </div> <div style="flex: 1; padding-left: 20px;"> <p>Width A on the test pattern produced should fall within the following range.</p> <p>Specifications: <math>4.2 \pm 0.5</math> mm                      Setting range: -3.0 mm to +3.0 mm                      (in 0.2 mm increments)</p> </div> </div>
Adjustment Instructions	<p>If width A is longer than the specifications, make the setting value smaller than the current one.</p> <p>If width A is shorter than the specifications, make the setting value greater than the current one.</p>
Setting/ Procedure	<ol style="list-style-type: none"> <li>Place A3 paper on the manual bypass tray.</li> <li>Call the Service Mode to the screen.</li> <li>Touch [Machine] → [Printer Area] → [Leading Edge Adj. (Duplex Side 2)].</li> <li>Select the [Plain Paper].</li> <li>Press the Start key to let the machine produce a test pattern.</li> <li>Check the dimension of width A on the test pattern.</li> <li>If width A falls outside the specified range, change the setting using the [+] / [-] key.</li> <li>Press the Start key to let the machine produce a test pattern.</li> <li>Check the dimension of width A on the test pattern.</li> <li>If width A is outside the specified range, change the setting again and make a check again.</li> <li>If width A falls within the specified range, touch [END].</li> <li>Following the same procedure, adjust for Thick paper.</li> </ol>

bizhub\_C353/C253/C203

Adjustment / Setting

### D. Centering (Duplex 2nd Side)

Functions	<ul style="list-style-type: none"> <li>To vary the print start position in the main scan direction for each paper source in the 2-Sided mode.</li> </ul>
Use	<ul style="list-style-type: none"> <li>The image on the backside of the 2-sided copy deviates in the main scan direction.</li> </ul>
Adjustment Specification	<div style="display: flex; align-items: center;"> <div style="flex: 1;"> </div> <div style="flex: 1; padding-left: 20px;"> <ul style="list-style-type: none"> <li>Width A on the test pattern produced should fall within the following range.</li> <li>For measurement, use the image produced on the backside of the test pattern.</li> </ul> <p>Specifications: <math>3.0 \pm 0.5</math> mm            Setting range: -3.0 mm to +3.0 mm            (in 0.2 mm increments)</p> </div> </div>
Adjustment Instructions	<ul style="list-style-type: none"> <li>If width A is longer than the specifications, make the setting value smaller than the current one.</li> <li>If width A is shorter than the specifications, make the setting value greater than the current one.</li> </ul>
Setting/ Procedure	<ol style="list-style-type: none"> <li>Call the Service Mode to the screen.</li> <li>Touch [Machine] → [Printer Area] → [Centering (Duplex 2nd Side)].</li> <li>Select the paper source to be adjusted.</li> <li>Press the Start key to let the machine produce a test pattern.</li> <li>Check the dimension of width A on the test pattern.</li> <li>If width A falls outside the specified range, change the setting using the [+] / [-] key.</li> <li>Press the Start key to let the machine produce a test pattern.</li> <li>Check the dimension of width A on the test pattern on the backside of the copy.</li> <li>If width A is outside the specified range, change the setting again and make a check again.</li> <li>If width A falls within the specified range, touch [END].</li> <li>Following the same procedure, adjust for all other paper sources. (Use A4 or 8 1/2 × 11 plain paper for the manual bypass tray.)</li> </ol>

**E. Paper Feed Direction Adj.**

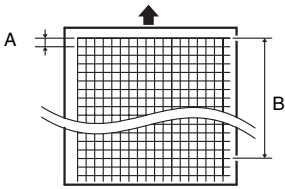
Functions	<ul style="list-style-type: none"> <li>To synchronize the paper transport speed with the image writing speed.</li> </ul>
Use	<ul style="list-style-type: none"> <li>Feed Direction Adjustment becomes necessary.</li> <li>The print image on the copy distorts (stretched, shrunk).</li> <li>When the print image on the copy is stretched in the sub scan direction.</li> <li>This setting can be made independently for plain paper, Thick 1, Thick 2, Thick 3, and Thick 4.</li> </ul>
Adjustment Specification	<div style="display: flex; align-items: center;"> <div style="flex: 1;">  <p style="text-align: center;">A00JF3C506DA</p> </div> <div style="flex: 1; padding-left: 20px;"> <p>Width A and width B on the test pattern produced should fall within the following ranges.                      Width A: equivalent to one grid                      Width B: equivalent to 48 grids</p> <p>Specifications                      A: 7.9 to 8.3                      B: 389.1 to 392.1</p> <p>Setting Range                      A, B: -7 to +7</p> </div> </div>
Adjustment Instructions	<p>If width A or B is longer than the specifications, make the setting value smaller than the current one.                  If width A or B is shorter than the specifications, make the setting value greater than the current one.</p>
Adjustment Procedure	<ol style="list-style-type: none"> <li>Load manual bypass tray with A3 or 11 × 17 plain paper.</li> <li>Call the Service Mode to the screen.</li> <li>Touch [Machine] → [Printer Area] → [Paper Feed Direction Adj.].</li> <li>Select [Plain Paper].</li> <li>Press the Start key to let the machine produce a test pattern.</li> <li>Check width A (equivalent to one grid) and width B (equivalent to 48 grids) on the test pattern.</li> <li>Touch these keys in this order: [Machine] → [Printer Area] → [Paper Feed Direction Adj].</li> <li>If width of A or B falls outside the specified range, change the setting using the [+]/[-] keys.</li> <li>Press the Start key to let the machine produce a test pattern again.</li> <li>Check width A and width B on the test pattern.</li> <li>If width A or B falls outside the specified range, change the setting value and make a check again.</li> <li>If width A or B falls within the specified range, touch [END].</li> <li>Following the same procedure, adjust for thick paper.</li> </ol>

bizhub\_C353/C253/C203

Adjustment / Setting

10.4.5 Scan Area

- Use the following color chart for the adjustment of the scanner section.
- If the color chart is not available, a scale may be used instead.

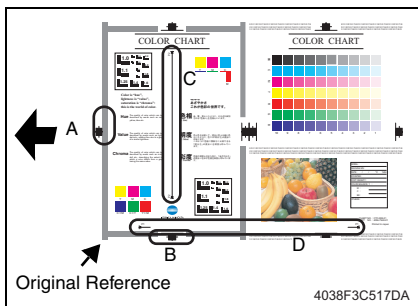

- A: Image Position: Leading Edge
- B: Image Position: Side Edge
- C: Cross Direction Adjustment
- D: Feed Direction Adjustment

A. Image Position: Leading Edge

Functions	<ul style="list-style-type: none"> <li>• To adjust variations in mounting accuracy and sensitivity of the scanner home sensor and in mounting accuracy of the original width scale by varying the scan start position in the main scan direction.</li> </ul>
Use	<ul style="list-style-type: none"> <li>• When the original glass is replaced.</li> <li>• When the original width scale is replaced.</li> </ul>
Adjustment Specification	<div style="display: flex; align-items: center;"> <div style="flex: 1;"> <p style="margin-left: 20px;">Color is lightness saturation this is the</p> <p style="margin-left: 20px;">Hue</p> <p style="margin-left: 20px;">Value</p> <p style="margin-left: 20px;">A00JF3C507DA</p> </div> <div style="flex: 1; padding-left: 20px;"> <ul style="list-style-type: none"> <li>• B width on the color chart and one on the copy sample are measured and adjusted so that the difference of A width satisfies the specifications shown below.</li> <li>• An adjustment must have been completed correctly of [Leading Edge Adjustment] of [Printer Area].</li> </ul> <p>Specifications</p> <p>A: ± 0.5 mm (10 ± 0.5 mm if a scale is used)</p> <p>Setting range</p> <p>-5.0 to +5.0 (in 0.1 mm increments)</p> </div> </div>
Adjustment Instructions	<p>If the copy image is less than the specified length, increase the setting value.</p> <p>If the copy image exceeds the specified length, decrease the setting value.</p>
Setting/ Procedure	<ol style="list-style-type: none"> <li>1. Call the Service Mode to the screen.</li> <li>2. Touch these keys in this order: [Machine] → [Scan Area] → [Image Position: Leading Edge].</li> <li>3. Position the color chart correctly so that the original reference point is aligned with the scale.</li> <li>4. Press the Start key to make a copy.</li> <li>5. Check point A on the image of the copy.</li> <li>6. If width A on the copy falls outside the specified range, change the setting using the [+] / [-] key.</li> <li>7. Press the Start key to make another copy.</li> <li>8. Check the image on the copy to see if the specifications are met.</li> <li>9. Make adjustments until the specifications are met.</li> </ol>

**B. Image Position: Side Edge**

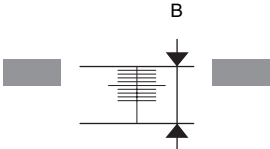
Functions	<ul style="list-style-type: none"> <li>To adjust part-to-part variations in accuracy of IR parts and their mounting accuracy by varying the scan start position in the main scan direction.</li> </ul>
Use	<ul style="list-style-type: none"> <li>When the CCD unit is replaced.</li> <li>When the original glass is replaced.</li> <li>The scanner home sensor has been replaced.</li> </ul>
Adjustment Specification	<div style="display: flex; align-items: center;">  <div style="margin-left: 20px;"> <ul style="list-style-type: none"> <li>A width on the color chart and one on the copy sample are measured and adjusted so that the difference of B width satisfies the specifications shown below.</li> <li>An adjustment must have been completed correctly of [Centering] of [Printer Area].</li> </ul> <p>Specifications B: ± 1.0 mm</p> <p>Setting range -10.0 to +10.0 (in 0.1 mm increments)</p> </div> </div> <p style="text-align: center; margin-top: 10px;">A00JF3C508DA</p>
Adjustment Instructions	<p>If the copy image is less than the specified length, increase the setting value. If the copy image exceeds the specified length, decrease the setting value.</p>
Setting/ Procedure	<ol style="list-style-type: none"> <li>Call the Service Mode to the screen.</li> <li>Touch these keys in this order: [Machine] → [Scan Area] → [Image Position: Side Edge].</li> <li>Position the color chart correctly so that the original reference point is aligned with the scale.</li> <li>Press the Start key to make a copy.</li> <li>Check point B on the image of the copy.</li> <li>If the image falls outside the specified range, change the setting using the [+] / [-] key.</li> <li>Press the Start key to make a copy.</li> <li>Check point B of the image on the copy to see if the specifications are met.</li> <li>Make adjustments until the specifications are met.</li> </ol>

### C. Cross Direction Adjustment

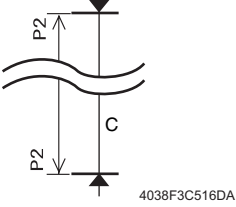
Functions	<ul style="list-style-type: none"> <li>To adjust the zoom ratio in the main scan direction for the scanner section.</li> </ul>
Use	<ul style="list-style-type: none"> <li>The CCD unit has been replaced.</li> </ul>
Adjustment Specification	<div style="display: flex; align-items: center;">  <div style="margin-left: 20px;"> <ul style="list-style-type: none"> <li>Measure C width on the color chart and on the sample copy, and adjust the gap to be within the following specification.</li> <li>An adjustment must have been completed correctly of "Paper Feed Direction Adj." of [Printer Area].</li> </ul> <p>Specifications C: <math>\pm 1.0</math> mm</p> <p>Setting range 0.990 to 1.010 (in 0.001 increments)</p> </div> </div>
Adjustment Instructions	<p>If the C width on the copy sample is less than one on color chart, increase the setting. If the C width on the copy sample exceeds one on color chart, decrease the setting.</p>
Setting/ Procedure	<ol style="list-style-type: none"> <li>Call the Service Mode to the screen.</li> <li>Touch these keys in this order: [Machine] → [Scan Area] → [Cross Direction Adjustment].</li> <li>Position the color chart correctly so that the original reference point is aligned with the scale.</li> <li>Press the Start key to make a copy.</li> <li>Check the C width on the image of the copy.</li> <li>If the image falls outside the specified range, change the setting using the [+] / [-] key.</li> <li>Press the Start key to make another copy.</li> <li>Check the image on the copy to see if the specifications are met.</li> <li>Make adjustments until the specifications are met.</li> </ol>

**D. Feed Direction Adjustment**

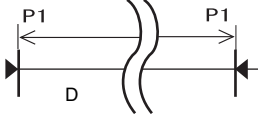
Functions	<ul style="list-style-type: none"> <li>To adjust the zoom ratio in the sub scan direction for the scanner section.</li> </ul>
Use	<ul style="list-style-type: none"> <li>The scanner assy has been replaced.</li> <li>The scanner motor has been replaced.</li> <li>The scanner drive cables have been replaced.</li> </ul>
Adjustment Specification	<div style="display: flex; align-items: center;">  <div style="margin-left: 20px;"> <ul style="list-style-type: none"> <li>Measure D width on the color chart and on the sample copy, and adjust the gap to be within the following specification.</li> <li>An adjustment must have been completed correctly of "Paper Feed Direction Adj." of [Printer Area].</li> </ul> <p>Specifications D: ± 1.5 mm</p> <p>Setting range 0.990 to 1.010 (in 0.001 increments)</p> </div> </div> <p style="text-align: center; font-size: small;">4038F3C518DA</p>
Adjustment Instructions	<p>If the D width on the copy sample is less than one on color chart, increase the setting. If the D width on the copy sample exceeds one on color chart, decrease the setting.</p>
Setting/ Procedure	<ol style="list-style-type: none"> <li>Call the Service Mode to the screen.</li> <li>Touch these keys in this order: [Machine] → [Scan Area] → [Feed Direction Adjustment].</li> <li>Position the color chart correctly so that the original reference point is aligned with the scale.</li> <li>Press the Start key to make a copy.</li> <li>Check the D width on the image of the copy.</li> <li>If the image falls outside the specified range, change the setting using the [+] / [-] key.</li> <li>Press the Start key to make another copy.</li> <li>Check the image on the copy to see if the specifications are met.</li> <li>Make adjustments until the specifications are met.</li> </ol>

bizhub C353/C253/C203

Adjustment / Setting



**10.4.6 Printer Resist Loop**

Functions	<ul style="list-style-type: none"> <li>To set the correction value of the paper loop length for each process speed of tray 1, tray 2 to tray 4 / LCT, bypass, and duplex.</li> <li>To adjust the length of the loop formed in paper before the registration rollers.</li> <li>Use "Paper Passage" for paper passage check.</li> </ul>																														
Use	<p>When a paper skew occurs.</p> <p>When a paper misfeed occurs.</p>																														
Adjustment Instructions	<p>To decrease the loop amount: Decrease the setting value</p> <p>To increase the loop amount: Increase the setting value</p>																														
Adjustment Range	<ul style="list-style-type: none"> <li>The adjustable range is different depending on paper source and processing speed.</li> </ul> <p>&lt;bizhub C353&gt;</p> <table border="1"> <thead> <tr> <th></th> <th>Tray 1/2</th> <th>Tray 3/4 LCT</th> <th>Duplex</th> <th>Manual Tray</th> </tr> </thead> <tbody> <tr> <td>166.6 mm/sec</td> <td>-5 to +5</td> <td>-5 to +5</td> <td>-5 to +5</td> <td>-5 to +5</td> </tr> <tr> <td>55 mm/sec</td> <td>-15 to +15</td> <td>-15 to +15</td> <td>-8 to +8</td> <td>-15 to +15</td> </tr> </tbody> </table> <p>&lt;bizhub C253/C203&gt;</p> <table border="1"> <thead> <tr> <th></th> <th>Tray 1/2</th> <th>Tray 3/4 LCT</th> <th>Manual</th> <th>Duplex</th> </tr> </thead> <tbody> <tr> <td>110 mm/sec</td> <td>-8 to +8</td> <td>-8 to +8</td> <td>-8 to +8</td> <td>-8 to +8</td> </tr> <tr> <td>55 mm/sec</td> <td>-15 to +15</td> <td>-15 to +15</td> <td>-8 to +8</td> <td>-15 to +15</td> </tr> </tbody> </table>		Tray 1/2	Tray 3/4 LCT	Duplex	Manual Tray	166.6 mm/sec	-5 to +5	-5 to +5	-5 to +5	-5 to +5	55 mm/sec	-15 to +15	-15 to +15	-8 to +8	-15 to +15		Tray 1/2	Tray 3/4 LCT	Manual	Duplex	110 mm/sec	-8 to +8	-8 to +8	-8 to +8	-8 to +8	55 mm/sec	-15 to +15	-15 to +15	-8 to +8	-15 to +15
	Tray 1/2	Tray 3/4 LCT	Duplex	Manual Tray																											
166.6 mm/sec	-5 to +5	-5 to +5	-5 to +5	-5 to +5																											
55 mm/sec	-15 to +15	-15 to +15	-8 to +8	-15 to +15																											
	Tray 1/2	Tray 3/4 LCT	Manual	Duplex																											
110 mm/sec	-8 to +8	-8 to +8	-8 to +8	-8 to +8																											
55 mm/sec	-15 to +15	-15 to +15	-8 to +8	-15 to +15																											
Setting/ Procedure	<ol style="list-style-type: none"> <li>Call the Service Mode to the screen.</li> <li>Touch these keys in this order: [Machine] → [Printer Resist Loop].</li> <li>Select a paper source and a processing speed where the settings are made by touching the corresponding keys.</li> <li>Enter the new setting from the 10-key pad.</li> </ol>																														

bizhub C353/C253/C203

Adjustment / Setting

### 10.4.7 Color Registration Adjustment

#### A. Cyan, Magenta, Yellow

Functions	<ul style="list-style-type: none"> <li>To adjust color shift if there is any when comparing the original with copy of the plain or thick paper.</li> </ul>
Use	<ul style="list-style-type: none"> <li>To correct any color shift.</li> <li>This setting can be made independently for plain paper, Thick 1, Thick 2, Thick 3, and Thick 4.</li> </ul>
Adjustment Range	"0" (-6 to +6 dot)
Adjustment Instructions	<p>If the cross deviates in the direction of A, increase the setting.                  If the cross deviates in the direction of B, decrease the setting.</p>
Setting/ Procedure	<ol style="list-style-type: none"> <li>Call the Service Mode to the screen.</li> <li>Touch these keys in this order: [Machine] → [Color Registration Adjustment].</li> <li>Load manual bypass tray with A3/11 x 17 or A4/8 1/2 x 11 plain paper.</li> <li>Press the Start key.</li> <li>On the test pattern produced, check for deviation between the black line and the line of each color at positions X and Y.</li> <li>Select the color to be adjusted.</li> <li>Using the [+]/[-] key, change the setting value as necessary. (At this time, only the line of the selected color moves.)</li> <li>Produce another test pattern and make sure that there is no deviation.</li> </ol> <p>Check Procedure</p> <p>Check point X, Y</p> <div style="text-align: center;"> </div> <p style="text-align: center;"><b>X</b>      A02EF3C501DA</p> <p><b>Adjustment for X direction:</b> Check point X</p> <div style="display: flex; justify-content: space-around;"> <div style="text-align: center;"> <p>Direction of A</p> <p>A02EF3C502DA</p> </div> <div style="text-align: center;"> <p>Direction of B</p> <p>A02EF3C503DA</p> </div> </div> <p><b>Adjustment for Y direction:</b> Check point Y</p> <div style="display: flex; justify-content: space-around;"> <div style="text-align: center;"> <p>Direction of A</p> <p>A02EF3C504DA</p> </div> <div style="text-align: center;"> <p>Direction of B</p> <p>A02EF3C505DA</p> </div> </div>

bizhub\_C353/C253/C203

Adjustment / Setting

**10.4.8 Exhaust Fan Stop Delay**

Functions	<ul style="list-style-type: none"> <li>To set the period of time before the exhaust fan motor stops.</li> </ul>
Use	<ul style="list-style-type: none"> <li>At the completion of a print job/image stabilization or at jam/malfunction, the fan motor rotating at full speed comes to a stop. The period of time before the fan motor stops can be delayed so that ozone left around the PC drum can be discharged.</li> </ul>
Setting/ Procedure	<ul style="list-style-type: none"> <li>0 to 15 (minutes) can be entered with the ten-key pad. (Default is 0.)</li> </ul> <p><b>NOTE</b></p> <ul style="list-style-type: none"> <li><b>When this setting is set to 0 (minute), the fan motor runs for 5 seconds before it stops.</b></li> </ul>

**10.4.9 LD adjustment**

**A. LD delay adjust.**

⚠ Functions	<ul style="list-style-type: none"> <li>Not used.</li> </ul>
Setting/ Procedure	<ul style="list-style-type: none"> <li>The default setting is 14.</li> </ul> <p><b>NOTE</b></p> <ul style="list-style-type: none"> <li><b>Do NOT change this setting from the default value.</b></li> </ul>

**B. LD lightness balance adjust.**

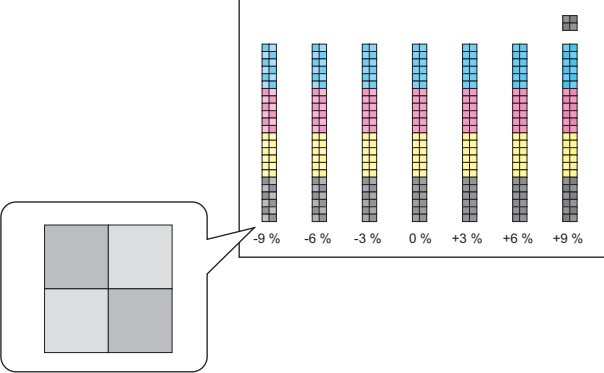
Functions	<ul style="list-style-type: none"> <li>This function adjusts the LD lightness balance between the two LDs to correct the difference of LD lightness between the LDs.</li> </ul>
Use	<ul style="list-style-type: none"> <li>This setting is made after the PH unit or the service EEPROM board is replaced.</li> <li>This adjustment is made to prevent uneven density in highlighted halftone area processed with error diffusion being caused by inappropriate laser intensity.</li> </ul>
Setting/ Procedure	<ol style="list-style-type: none"> <li>Call the Service Mode to the screen.</li> <li>Touch these keys in this order: [Machine] → [LD adjustment] → [LD lightness balance adjust.].</li> <li>Select [For adjustment] and press Start key.</li> <li>The test print includes seven rows of patterns produced with different levels of LD2 light intensity towards LD1.</li> </ol> <div style="text-align: center; margin: 10px 0;">  </div> <p style="text-align: right; margin-right: 20px;">A00JF3C527DA</p> <ol style="list-style-type: none"> <li>Three squares each made up by four small squares are printed with the different four colors. The two small squares diagonal to each other are printed using the same LD. Depending on individual print timing, it is decided that which pair of small squares corresponds to which LD. The pair of small squares where image density changes corresponds to LD2.</li> <li>From the test pattern, select the pattern where the least density difference appears between LD1 and LD2 for each color.</li> <li>Enter the adjustment value corresponding to the pattern you selected (see the above illustration) or a value close to the adjustment value using the ten key pads on the panel.</li> <li>Select [For effect confirmat.] and press Start key.</li> <li>Check that LD2 small squares have no image noise of woodgrain.</li> <li>Touch [OK].</li> </ol>

bizhub\_C353/C253/C203

Adjustment / Setting



### 10.4.13 Split Line Prior Detection

Functions	<ul style="list-style-type: none"> <li>To check the stain on the ADF original glass and display the result.</li> </ul>
Use	<ul style="list-style-type: none"> <li>To manually perform the pre-detection of the stain which is normally conducted when the main/sub power switch is turned ON, recovering from the sleep/low power mode, etc.</li> <li>[Split Line Prior Detection] will be conducted with the detection level set by the following setting. [Service Mode] → [System 2] → [Split Line Detect. Setting] → [Prior Detection] When the above setting is set to "Not Set", "NG" will be displayed even though the pre-detection is conducted.</li> </ul>
Setting/ Procedure	<ol style="list-style-type: none"> <li>Call the Service Mode to the screen.</li> <li>Touch these keys in this order: [Machine] → [Split Line Prior Detection].</li> <li>Press the start key to start the pre-detection.</li> <li>Check to make sure that "OK" is displayed for the result.</li> </ol> <p>* When the result says "NG", clean the glass and check again.</p>

## 10.5 Firmware Version

Functions	<ul style="list-style-type: none"> <li>To check the firmware version.</li> </ul>
Use	<ul style="list-style-type: none"> <li>Use when the firmware is upgraded.</li> <li>When the firmware is upgraded or PWB is replaced.</li> </ul>
Setting/ Procedure	<ol style="list-style-type: none"> <li>Call the Service Mode to the screen.</li> <li>Touch [Firmware Version].</li> <li>Select the appropriate key from 1 to 3 to check the Firmware Version.</li> </ol>

## 10.6 Imaging Process Adjustment

### 10.6.1 Gradation Adjust

- It will not be displayed when the following setting is set to "ON".  
[Service Mode] → [Image Process Adjustment] → [Dev. Bias Choice]

Functions	<ul style="list-style-type: none"> <li>To make an automatic adjustment of gradation based on the test pattern produced and the readings taken by the scanner.</li> </ul>
Use	<ul style="list-style-type: none"> <li>Color reproduction performance becomes poor.</li> <li>The IU has been replaced.</li> <li>The image transfer belt unit has been replaced.</li> <li>* The Adj. Values of "Dark" and "Highlight" shown on the gradation adjust screen represent how much corrections are made to produce an ideal image output. Conv. Value shows the difference from the ideal image density.</li> <li>* The closer the Conv. Value to 0, the more ideal the image.</li> <li>Stablizer : Before Gradation adjust, perform image stabilization.</li> <li>Gradation Mode : It gives the highest priority to gradation performance of the image as it adjusts.</li> <li>Resolution Mode : It gives the highest priority to reproduction performance of letters and lines as it adjusts.</li> <li>High Compression Mode : It gives the highest priority to increasing the number of images to be stored in the memory as it adjusts.</li> </ul>
Adjustment Specification	<p>Dark : 0 ± 100 Highlight : 0 ± 60</p>

Setting/ Procedure	<p>1. Call the Service Mode to the screen.</p> <p>2. Touch these keys in this order: [Image Process Adjustment] → [Gradation Adjust].</p> <p>3. Touch [Stabilizer] and the Start key to perform image stabilization.</p> <p><b>NOTE</b></p> <ul style="list-style-type: none"> <li>• <b>Before executing Gradation adjust, be sure to perform Stabilizer.</b></li> </ul> <p>4. Select the appropriate mode for the gradation adjustment.</p> <p>5. Press the Start key to let the machine produce a test pattern.</p> <p><b>NOTE</b></p> <ul style="list-style-type: none"> <li>• <b>When the image stabilization performed in step 3 is NG, the Start key stops functioning.</b></li> <li>• <b>When one of the alert codes, P-5, P-6, P-7, P-8, P-9, and P-28 is on the screen and [Gradation Mode] is selected, the Start key stops functioning.</b></li> </ul> <p>6. Place the test pattern produced on the original glass.</p> <p>7. Place ten blank sheets of A3/11x17 paper on the test pattern and lower the original cover.</p> <p>8. Press the Start key. (The machine will then start scanning the test pattern.)</p> <p>9. Touch [OK] and repeat steps from 4 through 8 twice (a total of three times).</p> <p>10. Touch [Gradation Adjust] to display the Adj. Values and Conv. Values of each color (C, M, Y and K) for Dark and Highlight.</p> <p>11. Use the following procedures to check the Conv. Value.</p> <p><b>Dark: <math>0 \pm 100</math> and Highlight: <math>0 \pm 60</math>: It completes the adjustment procedure.</b></p> <p><b>If neither Dark nor Highlight falls outside the ranges specified above: Perform steps from 4 to 8.</b></p> <p><b>NOTE</b></p> <ul style="list-style-type: none"> <li>• <b>If the convergence falls within the specified range after the second Gradation Adjustment, further adjustment may not be necessary.</b></li> <li>• If a fault is detected, "0" is displayed for all values. In that case, after turning off the main power switch, turn it on again more than 10 seconds after and then make the gradation adjustment again.</li> <li>• If either Dark or Highlight still remains outside the specified ranges perform D Max Density.</li> <li>• If a total of four sequences of gradation adjust do not bring the values into the specified range, check the image.</li> <li>• If the image is faulty, perform the troubleshooting procedures for image problems.</li> </ul>
-----------------------	--

**10.6.2 D Max Density**

Functions	<ul style="list-style-type: none"> <li>To adjust gradation, color, and image density to target reproduction levels by varying the maximum amount of toner sticking to paper through auxiliary manual fine-adjustment of gamma of each color after gradation adjust.</li> </ul>
Use	<ul style="list-style-type: none"> <li>An image quality problem is not corrected even after gradation adjust has been run.</li> </ul>
Adjustment Range	<ul style="list-style-type: none"> <li>The default setting is 0.</li> </ul> <p style="text-align: center;">-10 to +10 (step: 1 *)</p> <p>*: 1 step corresponds to 0.03 in density difference.</p>
Adjustment Instructions	<p>To increase the maximum amount of toner sticking, increase the setting value. To decrease the maximum amount of toner sticking, decrease the setting value.</p>
Setting/ Procedure	<ol style="list-style-type: none"> <li>Call the Service Mode to the screen.</li> <li>Touch these keys in this order: [Imaging Process Adjustment] → [D Max Density].</li> <li>Select [COPY] or [Printer].</li> <li>Select the color to be adjusted.</li> <li>Enter the new setting from the 10-key pad or [+/-].</li> <li>Touch [END] to return to the [Process] menu screen.</li> <li>Touch [Stabilizer].</li> <li>Touch [Stabilizer Mode].</li> <li>Press the Start key to validate the adjustment value.</li> <li>Check the copy image for any image problem.</li> </ol> <p><b>NOTE</b></p> <ul style="list-style-type: none"> <li>If the setting value has been changed, be sure to run an image stabilization sequence to make valid the new value.</li> </ul>

**10.6.3 TCR Level Setting**

Functions	<ul style="list-style-type: none"> <li>To adjust the T/C control level when an abnormal image density occurs as a result of a change in the amount of charge of toner and carrier due to an environmental change.</li> </ul>
Use	<ul style="list-style-type: none"> <li>Use when T/C changes due to changes in environmental conditions of the user site.</li> </ul>
Adjustment Range	<ul style="list-style-type: none"> <li>The default setting is 0.</li> </ul> <p style="text-align: center;">-3 to +3</p> <p>(1 step :0.5 %, Center value 0 corresponds to 7 % T/C ratio.)</p>
Adjustment Instructions	<p>To increase T/C, increase the setting value. To decrease T/C, decrease the setting value.</p>
Adjustment Procedure	<ol style="list-style-type: none"> <li>Call the Service Mode to the screen.</li> <li>Touch these keys in this order: [Process] → [TCR Level Setting].</li> <li>Select the color to be adjusted.</li> <li>Enter the new setting from the 10-Key Pad and [+/-] key.</li> <li>Touch [END] to validate the adjustment value.</li> <li>Check the copy image for any image problem.</li> </ol>

bizhub C353/C253/C203

Adjustment / Setting



### 10.6.4 Background Voltage Margin

Functions	<ul style="list-style-type: none"> <li>To adjust the highlight portion (fog level) to the target reproduction level by making an auxiliary manual fine-adjustment of <math>\gamma</math> of each color after gradation adjust.</li> </ul>
Use	<ul style="list-style-type: none"> <li>Use when a foggy background occurs due to a printer problem.</li> </ul>
Adjustment Range	<ul style="list-style-type: none"> <li>The default setting is 0.</li> </ul> <p style="text-align: center;">-5 to +5 (step: 1)</p>
Adjustment Instructions	<p>To make the background level foggier, decrease the setting value. To make the background level less foggy, increase the setting value.</p>
Setting/ Procedure	<ol style="list-style-type: none"> <li>Call the Service Mode to the screen.</li> <li>Touch these keys in this order: [Imaging Process Adjustment] → [Background Voltage Margin].</li> <li>Select the color to be adjusted.</li> <li>Enter the new setting from the 10-key pad.</li> <li>Touch [END] to return to the [Image Adjust] menu screen.</li> <li>Touch [Stabilizer].</li> <li>Touch [Stabilization Only].</li> <li>Press the Start key to validate the adjustment value.</li> <li>Check the copy image for any image problem.</li> </ol> <p><b>NOTE</b></p> <ul style="list-style-type: none"> <li>If the setting value has been changed, be sure to run an image stabilization sequence to make valid the new value.</li> </ul>

### 10.6.5 Transfer Output Fine Adjustment

#### A. Primary transfer adj.

Functions	<ul style="list-style-type: none"> <li>Adjust the output value for the 1st image transfer voltage.</li> </ul>
Use	<ul style="list-style-type: none"> <li>To use when white spots appeared.</li> </ul>
Adjustment Range	<ul style="list-style-type: none"> <li>The default setting is 0.</li> </ul> <p style="text-align: center;">-8 to +7 (step: 1)</p>
Adjustment Instructions	<p>Adjust the output value for the 1st image transfer voltage by; Increasing it: Increase the setting value (white spots will decrease) Decreasing it: Decrease the setting value</p>
Setting/ Procedure	<ol style="list-style-type: none"> <li>Call the Service Mode to the screen.</li> <li>Select [Test Mode] → [Halfone Pattern] to output the red or green test pattern. <a href="#">See P.428</a></li> <li>When the test pattern image has white spots, adjust with the following procedure.</li> <li>Touch these keys in this order: [Imaging Process Adjustment] → [Transfer Output Fine Adjustment].</li> <li>Select [Primary transfer adj.].</li> <li>Select the color.</li> <li>Change the setting value using the [+] / [-] keys.</li> <li>Touch [OK] key to set the adjustment value. Gradually increase the adjustment value to the acceptable white spots level while checking the test pattern.</li> </ol> <p><b>NOTE</b></p> <ul style="list-style-type: none"> <li>PC Drum memory may occur by taking measure to white spots occurred by increasing the 1st image transfer voltage to adjust it. Check the image on the test print or the color chart when adjusting.</li> </ul>

**B. Secondary transfer adj.**

Functions	<ul style="list-style-type: none"> <li>Adjust the 2nd image transfer output (ATVC) on the 1st page and the 2nd page for each paper type.</li> </ul>
Use	<ul style="list-style-type: none"> <li>To use when the transfer failure at the trailing edge occurs.</li> </ul>
Adjustment Range	<ul style="list-style-type: none"> <li>The default setting is 0. -8 to +7 (step: 1)</li> </ul>
Adjustment Instructions	<p>To increase the ATVC value (in the direction of a foggier image), increase the setting value. To decrease the ATVC value (in the direction of a less foggy image), decrease the setting value.</p>
Setting/ Procedure	<ol style="list-style-type: none"> <li>Call the Service Mode to the screen.</li> <li>Touch these keys in this order: [Imaging Process Adjustment] → [Transfer Output Fine Adjustment].</li> <li>Select [Secondary transfer adj.].</li> <li>Select the side of the image (1st side or 2nd side), on which the transfer failure occurs.</li> </ol> <p><b>NOTE</b></p> <ul style="list-style-type: none"> <li><b>For envelopes, only first side can be selected.</b></li> </ul> <ol style="list-style-type: none"> <li>Select the paper type with the transfer failure.</li> <li>Enter the new setting from the [+] / [-] keys.</li> <li>Touch [END] to validate the adjustment value.</li> <li>Check the print image for any image problem.</li> </ol>

**10.6.6 Stabilizer**

**A. Stabilization Only**

Functions	<ul style="list-style-type: none"> <li>The image stabilization sequence is carried out without clearing the historical data of image stabilization control.</li> </ul>
Use	<ul style="list-style-type: none"> <li>Use if an image problem persists even after gradation adjustment has been executed.</li> <li>When [D Max Density] and [Background Voltage Margin] of Service Mode are changed.</li> </ul>
Setting/ Procedure	<ol style="list-style-type: none"> <li>Call the Service Mode to the screen.</li> <li>Touch these keys in this order: [Imaging Process Adjustment] → [Stabilization Only].</li> <li>Press the Start key to start Stabilizer. The Start key turns red and stays lit up red during the Stabilizer sequence.</li> <li>Stabilizer is completed when the Start key turns blue.</li> </ol>

bizhub\_C353/C253/C203

Adjustment / Setting

**B. Initialize+Image Stabilization**

Functions	<ul style="list-style-type: none"> <li>To carry out an image stabilization sequence after the historical data of image stabilization control has been initialized.</li> </ul>
Use	<ul style="list-style-type: none"> <li>Use if an image problem persists even after gradation adjustment has been executed.</li> <li>Use if tone reproduction and maximum density are faulty even after Stabilizer Mode has been executed.</li> <li>When color shift correction is needed again after the machine maintenance.</li> <li>After executing the skew adjustment reset.</li> </ul>
Setting/ Procedure	<ol style="list-style-type: none"> <li>Call the Service Mode to the screen.</li> <li>Touch these keys in this order: [Imaging Process Adjustment] → [Stabilizer].</li> <li>Touch [Initialize+Image Stabilization].</li> <li>Press the Start key to start stabilizer. The Start key turns red and stays lit up red during the Stabilizer sequence.</li> <li>Stabilizer is completed when the Start key turns blue.</li> </ol>

**10.6.7 Thick Paper Density Adjustment**

Functions	<ul style="list-style-type: none"> <li>To fine-adjust density of printed images of each color for thick paper and OHP transparencies. (Only black color adjustable for OHP transparencies)</li> </ul>
Use	<ul style="list-style-type: none"> <li>To change the density of the printed image for each color with thick paper and OHP transparencies.</li> </ul>
Adjustment Range	<ul style="list-style-type: none"> <li>The default setting is 0. -5 to +5 (step: 1)</li> </ul>
Adjustment Instructions	<p>Light color: Touch the Darker key. Dark color: Touch the Lighter key.</p>
Setting/ Procedure	<ol style="list-style-type: none"> <li>Call the Service Mode to the screen.</li> <li>Touch these keys in this order: [Imaging Process Adjustment] → [Thick Paper Density Adjustment].</li> <li>Touch the Lighter or Darker key for the desired color to correct the image density.</li> </ol>

**10.6.8 TCR Toner Supply**

Functions	<ul style="list-style-type: none"> <li>To adjust the set T/C level by replenishing an auxiliary supply of toner when a low ID occurs due to a lowered T/C after large numbers of prints have been made of originals having a high image density.</li> </ul>
Use	<ul style="list-style-type: none"> <li>When there is a drop in T/C.</li> </ul>
Setting/ Procedure	<ol style="list-style-type: none"> <li>Call the Service Mode to the screen.</li> <li>Touch these keys in this order: [Imaging Process Adjustment] → [TCR Toner Supply].</li> <li>Select the color, for which supply of toner is to be replenished.</li> <li>Pressing the Start key will let the machine detect the current toner density and; if the density is lower than a reference value, a toner replenishing sequence and then a developer agitation sequence are run.</li> <li>These sequences are repeated up to a maximum of four times until the toner density reaches the reference value. If the toner density is found to be higher than the reference value, only a developer agitation sequence is carried out.</li> </ol>

**10.6.9 Monochrome Density Adjustment**

Functions	<ul style="list-style-type: none"> <li>To fine-adjust the density of the printed image for a black print.</li> </ul>
Use	<ul style="list-style-type: none"> <li>To vary the density of the printed image of a black print.</li> </ul>
Adjustment Range	<ul style="list-style-type: none"> <li>The default setting is 0.</li> </ul> <p style="text-align: center;">-2 to +2 (step: 1)</p>
Adjustment Instructions	<p>If the black is light, touch the Darker key.                  If the black is dark, touch the Lighter key.</p>
Setting/ Procedure	<ol style="list-style-type: none"> <li>Call the Service Mode to the screen.</li> <li>Touch these keys in this order: [Imaging Process Adjustment] → [Monochrome Density Adjustment].</li> <li>Touch [Lighter] or [Darker] as necessary to correct the image density.</li> </ol>

**10.6.10 Dev. Bias Choice**

Functions	<ul style="list-style-type: none"> <li>To change the setting of the developing bias voltage.</li> <li>When this function is turned ON, it decreases the developing bias voltage, thereby preventing voltage leak from occurring.</li> </ul>
Use	<ul style="list-style-type: none"> <li>Use when patches of white occur in the image in an ambience of low atmospheric pressure, such as in high altitudes.</li> <li>If ON is set, the screen doesn't display [Service Mode] → [Imaging Process Adjustment] → [Gradation Adjust] and the Gradation Adjust is not allowed.</li> </ul>
Setting/ Procedure	<ul style="list-style-type: none"> <li>The default setting is OFF.</li> </ul> <p style="text-align: center;">ON <span style="margin-left: 200px;">"OFF"</span></p>

bizhub C353/C253/C203

Adjustment / Setting

## 10.7 CS Remote Care

### 10.7.1 Outlines

- CS Remote Care enables the machine and the computer at CS Remote Care center to exchange data through telephone/fax line in order to control the machine.
- CS Remote Care enables the machine to call the computer at the center when trouble occurs. It also enables the computer at the center to contact the machine for the necessary data.
- Data which CS Remote Care handles can be divided into the following groups.
  - a. Data which show the status of use of the machine such as total count, PM count.
  - b. Data which show the abnormal situation on the machine such as where and how often errors occur.
  - c. Data on adjustment
  - d. Data on setting

**NOTE**

- **It cannot be set when the following setting is set to "ON".**  
**[Administrator Settings] → [Security Settings] → [Enhanced Security Mode]**

### 10.7.2 Setting up the CS Remote Care

**NOTE**

- **For resetting up the machine which CS Remote Care has already been set up, clear the RAM for CS Remote Care before resetting.**  
[See P.379](#)
- **When using a telephone line modem for connection, use the data modem which is based on the ITU-T recommendations V.34/V.32 bis/V.32 and AT command.**

Step	Procedure		
	Using the telephone line modem	Using the Fax line modem *1	Using E-mail
0	Register the device ID to the application at CS Remote Care center. The initial connection is not available unless the device ID is registered.		
1	Connecting the modem Turn the power for the modem OFF. Connect the machine and the modem with a modem cable. Connect the modem and the wall jack with a modular cable. * For connecting the modular cable, see the manual for the modem.	Be sure to remove the telephone line modem when the fax line is used.	Be sure to remove the telephone line modem when e-mail is used.
2	Clearing the RAM 1. Select [Service Mode] → [CS Remove Care], and touch [Detail Setting]. 2. Touch [RAM Clear]. 3. Select Set, and touch [OK]. <a href="#">See P.379</a>		

Step	Procedure		
	Using the telephone line modem	Using the Fax line modem *1	Using E-mail
3	Selecting the CS Remote Care function Select [Service Mode] → [CS Remove Care] → [System Selection], and touch [Modem].	Selecting the CS Remote Care function Select [Service Mode] → [CS Remove Care] → [System Selection], and touch [Fax].	Selecting the CS Remote Care function Select [Service Mode] → [CS Remote Care] → [System Setting], and touch [E-Mail 1] or [E-Mail 2].
4	Inputting the ID Code 1. Select [Service Mode] → [CS Remote Care] → [ID Code], and touch [ID Code]. 2. Input the seven digits ID of the service person, and touch [ID Code] again. <a href="#">See P.377</a>		
5	Setting the date and time for CS Remote Care 1. Select [Service Mode] → [CS Remote Care], and touch [Detail Setting]. 2. Touch [Date & Time Setting]. 3. Input the date, time and the time zone using the 10-key pad, and touch [Set]. <a href="#">See P.378</a>		
6	Setting the Center ID 1. Select [Service Mode] → [CS Remote Care], and touch [Detail Setting]. 2. Touch [Machine Setting] → [Center ID], and input the Center ID (five digits). <a href="#">See P.378</a>		
7	Setting the Device ID 1. Select [Service Mode] → [CS Remote Care], and touch [Detail Setting]. 2. Touch [Machine Setting] → [Device ID], and input Device ID (nine digits). <a href="#">See P.378</a>		
8	Proceed to step 9.		Encryption setting 1. Select [Service Mode] → [CS Remote Care], and touch [Detail Setting]. 2. Touch [Basic Setting] and select either Encryption or No Encryption.  Retransmission interval on e-mail delivery error • When selecting [E-mail2], set the retransmission interval on e-mail delivery error in software SW setting. <a href="#">See P.371</a>
9	Setting the telephone number of the Center 1. Select [Service Mode] → [CS Remote Care], and touch [Detail Setting]. 2. Touch [Machine Setting] → [Center Telephone Number]. 3. Input the telephone number of the center using the 10-keys pad and [P], [T], [W], [-]. <a href="#">See P.378</a>		Setting the Respond Timeout 1. Select [Service Mode] → [CS Remote Care], and touch [Detail Setting]. 2. Touch [Respond Timeout] and enter the response timeout using the 10-key pad. <b>NOTE</b> • <b>Under normal conditions, there is no need to change the default setting.</b> <a href="#">See P.378</a>
10	Inputting the device telephone number 1. Select [Service Mode] → [CS Remote Care], and touch [Detail Setting]. 2. Touch [Machine Setting] → [Device Telephone Number]. 3. Input the Device telephone number using the 10-key pad and [P], [T], [W], [-]. <a href="#">See P.378</a>		Proceed to step 11.

Step	Procedure		
	Using the telephone line modem	Using the Fax line modem *1	Using E-mail
11	Inputting the AT command for initializing the modem 1. Select [Service Mode] → [CS Remote Care] → and touch [Detail Setting]. 2. Touch [AT Command]. 3. Input AT Command. <b>NOTE</b> <ul style="list-style-type: none"> <li>• <b>Change this command only when it is necessary. (They do not need to be changed in normal condition.)</b></li> <li>• <b>For details on AT command, see the manual for the modem.</b></li> </ul> <a href="#">See P.380</a>	Proceed to step 12.	Setting the E-mail address 1. Select [Service Mode] → [CS Remote Care], and touch [Server Set]. 2. Touch [Server for RX], and set POP3 server address, POP3 login name, POP3 password and POP3 port number. <a href="#">See P.380</a> 3. Press [Receive], and set the E-Mail address, Mail Check, Connection Time Out and APOP Authentication. <a href="#">See P.380</a> 4. Touch [Send], and set the SMTP server address, SMTP port number, Connection Time Out, and APOP Authentication. <a href="#">See P.380</a> 5. Touch [TX/RX Test], and press Start key to carry out a transmission/reception test. If it fails to exchange messages, see the error message to take necessary measure, and try again. <a href="#">See P.380</a>
12	Setting the DIPSW for CS Remote Care <b>NOTE</b> <ul style="list-style-type: none"> <li>• <b>This setting is not normally necessary. Take this step only when necessary in a specific connecting condition.</b></li> </ul>		Proceed to step 13.
13	Executing the initial transmission 1. Select [Service Mode] → [CS Remote Care], and touch [Detail Setting]. 2. Touch [initial transmission] key on the right bottom of the screen to start initial transmission. 3. When the machine is properly connected with the center, CS Remote Care setting screen will be displayed. <b>NOTE</b> <ul style="list-style-type: none"> <li>• <b>The initial transmission key at the right bottom of the screen will be displayed only when the center ID, the device ID, Telephone number of the center and the device telephone number have been input.</b></li> </ul> <a href="#">See P.378</a>		Receiving the initial connection E-mail message Sending the initial connection E-mail message from the center to the address of the copier. <b>NOTE</b> <ul style="list-style-type: none"> <li>• <b>When receiving the initial connection E-mail message from the center while CS Remote Care-related screen is being displayed, the current setting information will be deleted, and CS Remote Care setting will be displayed.</b></li> <li>• <b>For sending the initial connection E-mail, see the manual for CS Remote Care center.</b></li> <li>• <b>Messages can be exchanged only between the center with initial connection and the copier.</b></li> <li>• <b>The initial connection from the center will be carried out, and the E-mail address of the center will be stored in the copier.</b></li> <li>• <b>When the initial registration is complete, the E-mail address of the center will be displayed by selecting [Service Mode] → [CS Remote Care] → [Detail Setting], [Basic Setting] → [E-Mail address].</b></li> </ul>

### 10.7.3 Software SW setting for CS Remote Care

#### NOTE

- **SW bits data are written into the NVRAM every time a change is made. In case you changed bit data by accident, be sure to restore the previous state.**

#### A. Input procedure

1. Select [Service Mode] → [CS Remote Care] → [Detail Setting], and touch [Software Switch Setting].
2. Touch [Switch No.], and input the switch number (two digits) using the 10-key pad.
3. Touch [Bit Assignment], and select switch bit number using the arrow keys, and input 0 or 1 using the 10-key pad.  
(For setting by hexadecimal numbers, touch [HEX Assignment] key, and input using the 10-key pad or A to F keys.)
4. Touch [Fix].

#### NOTE

- **About functions of each switch, see to “B. List of software SW for CS Remote Care.”**

#### B. List of software SW for CS Remote Care

#### NOTE

- **Do not change any bit not described on this table.**

SW No.	Bit	Functions	0	1	Default
SW 01	0	Dial mode	Pulse	Tone	1
	1	Reservation	—	—	0
	2	Reservation	—	—	0
	3	Reservation	—	—	0
	4	Baud rate	*1	*1	0
	5		*1	*1	0
	6		*1	*1	0
7	*1		*1	1	
SW 02	0	Emergency transmission	Do not call	Call	1
	1	Auto call on date specification	Do not call	Call	1
	2	Reservation	—	—	0
	3	Reservation	—	—	0
	4	Reservation	—	—	0
	5	Auto call on the IC Life	Do not call	Call	1
	6	Auto call on CCD clamp/gain adjustment failure	Do not call	Call	1
7	Reservation	—	—	0	
SW 03	0	Reservation	—	—	0
	1	Auto call on the toner empty	Do not call	Call	1
	2	Reservation	—	—	0
	3	Auto call on the waste toner bottle full	Do not call	Call	1
	4 to 7	Reservation	—	—	0
SW 04	0 to 7	Reservation	—	—	0



SW No.	Bit	Functions	0	1	Default
SW 05	0	Modem redial interval	*2	*2	1
	1		*2	*2	1
	2		*2	*2	0
	3		*2	*2	0
	4 to 7	Reservation	—	—	0
SW 06	0	Modem redial times	*3	*3	0
	1		*3	*3	1
	2		*3	*3	0
	3		*3	*3	1
	4		*3	*3	0
	5		*3	*3	0
	6	*3	*3	0	
	7	Reservation	—	—	0
SW 07	0	Redial for response time out	Do not redial	Redial	1
	1 to 7	Reserved	—	—	0
SW 08	0	Retransmission interval on e-mail delivery error	*4	*4	0
	1		*4	*4	1
	2		*4	*4	1
	3		*4	*4	0
	4 to 7	Reservation	—	—	0
SW 09	0	Retransmission times on e-mail delivery error	*5	*5	0
	1		*5	*5	1
	2		*5	*5	0
	3		*5	*5	1
	4		*5	*5	0
	5		*5	*5	0
	6	*5	*5	0	
	7	Reservation	—	—	0
SW 10	0 to 7	Reservation	—	—	0
SW 11	0	Timer 1	*6	*6	0
	1	RING reception → CONNECT reception	*6	*6	0
	2		*6	*6	0
	3		*6	*6	0
	4		*6	*6	0
	5		*6	*6	1
	6		*6	*6	0
	7		*6	*6	0

SW No.	Bit	Functions	0	1	Default
SW 12	0	Timer 2 Dial request completed → CONNECT reception	*7	*7	0
	1		*7	*7	0
	2		*7	*7	0
	3		*7	*7	0
	4		*7	*7	0
	5		*7	*7	0
	6		*7	*7	1
	7		*7	*7	0
SW 13	0 to 7	Reservation	—	—	0
SW 14	0	Timer 4 Line connection → Start request telegram delivery	*8	*8	0
	1		*8	*8	0
	2		*8	*8	0
	3		*8	*8	0
	4		*8	*8	0
	5		*8	*8	1
	6		*8	*8	0
	7		*8	*8	0
SW 15	0	Timer 5 Wait time for other side's response	*9	*9	0
	1		*9	*9	1
	2		*9	*9	1
	3		*9	*9	1
	4		*9	*9	1
	5		*9	*9	0
	6		*9	*9	0
	7		*9	*9	0
SW 16	0 to 7	Reservation	—	—	0
SW 17	0 to 7	Reservation	—	—	0
SW 18	0	Attention display To set weather to give the alarm display when using the modem but the power for the modem is OFF.	Do not call	Call	1
	1 to 7	Reservation	—	—	0
SW 19 to SW 40	0 to 7	Reservation	—	—	0

bizhub C353/C253/C203

Adjustment / Setting

## \*1: Baud rate

Mode	01-7	01-6	01-5	01-4
9600 bps	0	1	1	0
19200 bps	0	1	1	1
"38400 bps"	1	0	0	0

## \*2: Modem redial interval

Mode	05-3	05-2	05-1	05-0
1 minute	0	0	0	1
2 minutes	0	0	1	0
"3 minutes"	0	0	1	1
4 minutes	0	1	0	0
5 minutes	0	1	0	1
6 minutes	0	1	1	0
7 minutes	0	1	1	1
8 minutes	1	0	0	0
9 minutes	1	0	0	1
10 minutes	1	0	1	0

## \*3: Modem redial times

Mode	06-6	06-5	06-4	06-3	06-2	06-1	06-0
0 to 9 times	000 0000 to 000 1001						
"10 times"	0	0	0	1	0	1	0
11 to 99 times	000 1011 to 110 0011						

## \*4: Retransmission interval on e-mail delivery error

Mode	08-3	08-2	08-1	08-0
0 minute	0	0	0	0
10 minutes	0	0	0	1
20 minutes	0	0	1	0
30 minutes	0	0	1	1
40 minutes	0	1	0	0
50 minutes	0	1	0	1
"60 minutes"	0	1	1	0
70 minutes	0	1	1	1
80 minutes	1	0	0	0
90 minutes	1	0	0	1
100 minutes	1	0	1	0
110 minutes	1	0	1	1
120 minutes	1	1	0	0

## \*5: Retransmission times on e-mail delivery error

Mode	09-6	09-5	09-4	09-3	09-2	09-1	09-0
0 to 9 times	000 0000 to 000 1001						
"10 times"	0	0	0	1	0	1	0
11 to 99 times	000 1011 to 110 0011						

## \*6: Timer 1 (RING reception → CONNECT reception)

Mode	11-7	11-6	11-5	11-4	11-3	11-2	11-1	11-0
0 to 31 sec	0000 0000 to 0001 1111							
"32 sec"	0	0	1	0	0	0	0	0
33 to 255 sec	0010 0001 to 1111 1111							

## \*7: Timer 2 (Dial request completed → CONNECT reception)

Mode	12-7	12-6	12-5	12-4	12-3	12-2	12-1	12-0
0 to 63 sec	0000 0000 to 0011 1111							
"64 sec"	0	1	0	0	0	0	0	0
65 to 255 sec	0100 0001 to 1111 1111							

## \*8: Timer 4 (Line connection → Start request telegram delivery)

Mode	14-7	14-6	14-5	14-4	14-3	14-2	14-1	14-0
0 to 31 (x 100 msec)	0000 0000 to 0001 1111							
"32 (x 100 msec)"	0	0	1	0	0	0	0	0
33 to 255 (x 100 msec)	0010 0001 to 1111 1111							

## \*9: Timer 5 (Wait time for other side's response)

Mode	15-7	15-6	15-5	15-4	15-3	15-2	15-1	15-0
0 to 29 sec	0000 0000 to 0001 1101							
"30 sec"	0	0	0	1	1	1	1	0
31 to 255 sec	0001 1111 to 1111 1111							

### 10.7.4 Setup confirmation

- **Follow the steps below to make sure that CS Remote Care has been properly set up.**
  1. Call the Service Mode to the screen.
  2. Touch [CS Remote Care].
  3. Check to make sure that only selected item is displayed.

### 10.7.5 Calling the maintenance

- When CE starts maintenance, inputting the ID code of CE (seven digits: numbers which CE can identify. They are controlled by the distributor.) will transmit the information to the Center side and tells that the maintenance has started. When the maintenance is finished, touching [Maintenance Complete] key will transmit the information to the center and tells that it is finished.

#### A. When starting the maintenance

1. Select Service Mode and touch [CS Remote Care].
2. Touch [ID Code], and input ID Code.
3. Touch [ID Code].

\* The Start key blinks while maintenance is being carried out.

#### B. When finishing the maintenance

1. Select Service Mode and touch [CS Remote Care].
2. Touch [Maintenance Complete].

**10.7.6 Calling the center from the administrator**

- When the CS Remote Care setup is complete, the administrator can call the CS Remote Care center.
  1. Select [Administrator Settings], and touch [System Connection].
  2. Touch [Admin. transmission].
  3. Press the Start key.

When the setup is not complete or another transmission is being carried out, the Admin. transmission key will not be displayed, and the transmission is not available.

**NOTE**

- **For transmitting data of the machine by calling the center on the specified date and time, refer to the manual for CS Remote Care center.**

**10.7.7 Checking the transmission log**

- The transmission log list will be output to be checked.
  1. Select [Service Mode] → [CS Remote Care], and touch [Detail setting].
  2. Touch [Communication Log Print].
  3. Load tray 1 or bypass tray with A4S paper.
  4. Press the Start key to output transmission log.

**10.7.8 Detail on settings**

**A. System Selection**

Functions	• To select the system type for remote diagnosis.
Use	• Use to newly build or change the system.
Setting/ Procedure	<ul style="list-style-type: none"> <li>• Select E-Mail, Modem, or Fax.</li> <li>• Fax is available only when the optional fax kit is being installed.</li> </ul> <div style="display: flex; justify-content: space-around; margin-top: 10px;"> <span>E-Mail</span> <span>Modem</span> <span>Fax</span> </div>

**B. ID Code**

Functions	• To register the service ID.
Use	• Use when registering and changing service ID.
Setting/ Procedure	<ul style="list-style-type: none"> <li>• Enter a 7-digit code from the 10-key pad. (0000001 to 9999999)</li> </ul> <p>&lt;Registration&gt;</p> <ul style="list-style-type: none"> <li>• Touch ID code and enter the service ID.</li> <li>• Touch [ID code] to register the ID.</li> <li>• The [Detail Setting] will appear when the ID has been registered.</li> </ul>

**C. Detail Setting**

**(1) Basic Setting**

Functions	<ul style="list-style-type: none"> <li>Execute the primary setting.</li> </ul>																								
Use	<ul style="list-style-type: none"> <li>Use to change the set contents.</li> <li>Use to register the machine to the CS Remote Care center.</li> </ul>																								
Setting/ Procedure	<p>1. Call the Service Mode to the screen.                  2. Touch [CS Remote Care].                  3. Touching the [Detail Setting] will display the primary setting.</p> <p>&lt;Center Setting&gt;</p> <ul style="list-style-type: none"> <li>Set the center ID, Device ID, and the phone No.</li> <li>When e-mail is selected for system and all setup procedures are completed, e-mail address of the center is displayed.</li> </ul> <p>* When entering the phone number, 10-keys and keys on the screen have following meanings.</p> <p>[-] Pose : Waits to start transmitting after dialing                  [W] Wait : Detects the dial tone of the other end                  [T] Tone dial : Carry out tone dialing                  [P] Pulse dial : Carry out pulse dialing                  [*], [#] : To be used as necessary</p> <p>&lt;Schedule (Only when the [E-Mail2] is selected)&gt;</p> <ul style="list-style-type: none"> <li>Set the schedule of notification to the center.</li> <li>Up to three different notification schedules can be registered.</li> <li>Select the notification cycle from [Day], [Week], or [Month].                      When selecting [Day] for the notification cycle, set the Day Frequency.                      When selecting [Week] for the notification cycle, set the Week Frequency and day of the week.                      When selecting [Month], set the Month Frequency and the date of the month.</li> </ul> <p>&lt;Center Notification (Only when the [E-Mail2] is selected)&gt;</p> <ul style="list-style-type: none"> <li>Select the items of data that will be sent to the center in one-way transmission through E-Mail2.</li> <li>The following table shows each of the notification item keys and corresponding data.</li> </ul> <table border="1" style="width: 100%; border-collapse: collapse;"> <tr> <td style="width: 25%;">[1] Sales count data</td> <td style="width: 25%;"></td> <td style="width: 25%;">[7] EKC data</td> <td style="width: 25%;"></td> </tr> <tr> <td>[2] Error count data</td> <td></td> <td>[8] Adjustment data</td> <td></td> </tr> <tr> <td>[3] Service count data</td> <td></td> <td>[9] Coverage data</td> <td></td> </tr> <tr> <td>[4] Life count data Life cycle data</td> <td></td> <td>[10] Not used</td> <td></td> </tr> <tr> <td>[5] CSRC-System data Device config data</td> <td></td> <td>[11] Not used</td> <td></td> </tr> <tr> <td>[6] History data</td> <td></td> <td>[12] Not used</td> <td></td> </tr> </table>	[1] Sales count data		[7] EKC data		[2] Error count data		[8] Adjustment data		[3] Service count data		[9] Coverage data		[4] Life count data Life cycle data		[10] Not used		[5] CSRC-System data Device config data		[11] Not used		[6] History data		[12] Not used	
[1] Sales count data		[7] EKC data																							
[2] Error count data		[8] Adjustment data																							
[3] Service count data		[9] Coverage data																							
[4] Life count data Life cycle data		[10] Not used																							
[5] CSRC-System data Device config data		[11] Not used																							
[6] History data		[12] Not used																							
	<p><b>NOTE</b></p> <ul style="list-style-type: none"> <li><b>Multiple items of data can be selected and sent at one time. However, be sure that only EKC data cannot be sent together with other items of data.</b></li> </ul> <p>Initial Transmission</p> <ul style="list-style-type: none"> <li>Touching the Initial Transmission key will sent the information to the CS Remote Care center to register the machine.                      (Only when the modem or fax is selected on the system Input.)</li> </ul>																								

### (2) Date & Time Setting

Functions	<ul style="list-style-type: none"> <li>To set the data and time-of-day.</li> </ul>
Use	<ul style="list-style-type: none"> <li>Use to set or change the date and time-of-day.</li> </ul>
Setting/ Procedure	<ol style="list-style-type: none"> <li>Call the Service Mode to the screen.</li> <li>Touch [CS Remote Care].</li> <li>Touch [Detail Setting] to access Date &amp; Time Setting.</li> <li>Enter the date (month, day and year), time-of-day, and the time zone from the 10-key pad.</li> <li>Touch [SET] to start the clock.</li> </ol>

### (3) RAM Clear

Functions	<ul style="list-style-type: none"> <li>To clear the following data at the center ID Code, Primary Setting, Date/Time Input (Time Zone), Software SW Setting and AT Command.</li> </ul>
Use	<ul style="list-style-type: none"> <li>To be used for setting CS Remote Care.</li> <li>To be used for reset the every data of the center to default.</li> </ul> <p><b>NOTE</b></p> <ul style="list-style-type: none"> <li><b>If RAM clear is selected during transmission, RAM clear processing will be implemented at the time the transmission is completed regardless of whether it is done properly or not.</b></li> </ul>
Setting/ Procedure	<ul style="list-style-type: none"> <li>The default setting is "Unset."</li> </ul> <p style="text-align: center;">Set <span style="float: right;">"Unset"</span></p>

### (4) Communication Log Print

Functions	<ul style="list-style-type: none"> <li>To print out the communication log.</li> </ul>
Use	<ul style="list-style-type: none"> <li>Use to output and use the communication log.</li> </ul>
Setting/ Procedure	<ol style="list-style-type: none"> <li>Call the Service Mode on the screen.</li> <li>Touch [CS Remote Care].</li> <li>Touch [Detail Setting] to access communication log print.</li> <li>Load tray 1 or bypass tray with A4S or 8 1/2 x 11 paper.</li> <li>Press Start key to print out the communication log.</li> </ol>

### (5) Software Switch Setting

Functions	<ul style="list-style-type: none"> <li>To change the CS Remote Care settings.</li> </ul>
Use	<ul style="list-style-type: none"> <li>To change the settings for CS Remote Care as necessary.</li> </ul>
Setting/ Procedure	<ul style="list-style-type: none"> <li>Refer to "Software SW setting for CS Remote Care" for the setting.</li> </ul> <p><a href="#">See P.371</a></p>

### (6) Response Time Out

Functions	<ul style="list-style-type: none"> <li>It sets the intervals for resending e-mails when transmission error occurred.</li> <li>It can be set only when [E-Mail] is selected by System Setting.</li> </ul>
Use	<ul style="list-style-type: none"> <li>To use when changing the intervals for resending e-mails when transmission error occurred.</li> </ul>
Setting/ Procedure	<ul style="list-style-type: none"> <li>The default setting is 60 minute.</li> </ul> <p style="text-align: center;">"60 minute" (10 to 1440)</p>



**D. AT Command**

Functions	<ul style="list-style-type: none"> <li>To set the command to be issued at the time of modem initialization.</li> <li>This setting is available only when [Modem] is selected for the system setting.</li> </ul>
Use	<ul style="list-style-type: none"> <li>To set the command to be issued at the time of modem initialization.</li> </ul>
Setting/ Procedure	<ul style="list-style-type: none"> <li>Enter the command and touch [SET] to register.</li> </ul>

**E. Server Setting**

- Server Setting can be set only when [E-Mail] is selected by System Setting.

**(1) Server for RX**

<POP3 server>

Functions	<ul style="list-style-type: none"> <li>To set the POP3 server address used for the CS Remote Care.</li> </ul>
Use	<ul style="list-style-type: none"> <li>To set the address of the POP3 Server.</li> <li>POP3 server address can be set with IP address or the domain name.</li> </ul>
Setting/ Procedure	<p>&lt;Input IP Address&gt;</p> <ul style="list-style-type: none"> <li>IP address version 4 format [0 to 255].[0 to 255].[0 to 255].[0 to 255]</li> </ul> <p>&lt;Input FQDN&gt;</p> <ul style="list-style-type: none"> <li>Enter the domain name.</li> </ul>

<POP3 login name>

Functions	<ul style="list-style-type: none"> <li>To set the logon name for the POP3 server used for the CS Remote Care.</li> </ul>
Use	<ul style="list-style-type: none"> <li>To set the logon name for the POP3 server.</li> </ul>
Setting/ Procedure	<ul style="list-style-type: none"> <li>The default setting is No.</li> <li>Up to 64 characters (alphanumeric characters and symbols) can be used.</li> </ul>

<POP3 password>

Functions	<ul style="list-style-type: none"> <li>To set the logon password for the POP3 server used for the CS Remote Care.</li> </ul>
Use	<ul style="list-style-type: none"> <li>To set the logon password for the POP3 server.</li> </ul>
Setting/ Procedure	<ul style="list-style-type: none"> <li>The default setting is No.</li> <li>Up to 15 characters (alphanumeric characters and symbols) can be used.</li> </ul>

<POP3 port number>

Functions	<ul style="list-style-type: none"> <li>To set the POP3 port number used for the CS Remote Care.</li> </ul>
Use	<ul style="list-style-type: none"> <li>To set the port number for the POP3 server.</li> </ul>
Setting/ Procedure	<ul style="list-style-type: none"> <li>The default setting is 110.</li> </ul> <p style="text-align: right;">"110" (1 to 65535)</p>

**(2) Receive**

<E-mail Address>

Functions	<ul style="list-style-type: none"> <li>To set the e-mail address used for the CS Remote Care.</li> </ul>
Use	<ul style="list-style-type: none"> <li>To set the e-mail address.</li> </ul>
Setting/ Procedure	<ul style="list-style-type: none"> <li>The default setting is No.</li> <li>Up to 129 characters (alphanumeric characters and symbols) can be used.</li> </ul>

<Mail Check>

Functions	<ul style="list-style-type: none"> <li>To set whether or not to use mail check and the time interval for the POP server used for the CS Remote Care.</li> </ul>
Use	<ul style="list-style-type: none"> <li>To set whether or not to use mail check and the time interval for the POP server used for the CS Remote Care.</li> <li>To change the time interval for mail check.</li> </ul>
Setting/ Procedure	<ul style="list-style-type: none"> <li>The default setting is No.</li> </ul> <p style="text-align: center;">"No" (1 to 120 min., No)</p>

<Connection timeout>

Functions	<ul style="list-style-type: none"> <li>To set the timeout period for connection during reception.</li> </ul>
Use	<ul style="list-style-type: none"> <li>To change the timeout period for connection during reception.</li> </ul>
Setting/ Procedure	<ul style="list-style-type: none"> <li>The default setting is 60 Sec.</li> </ul> <p style="text-align: center;">"60 Sec" (30 to 300 Sec)</p>

<APOP Authentication>

Functions	<ul style="list-style-type: none"> <li>To set whether or not to authenticate the APOP during reception.</li> </ul>
Use	<ul style="list-style-type: none"> <li>To authenticate the APOP during reception.</li> </ul>
Setting/ Procedure	<ul style="list-style-type: none"> <li>The default setting is No.</li> </ul> <p style="text-align: center;">Yes <span style="margin-left: 200px;">"No"</span></p>

**(3) Send**

<SMTP server>

Functions	<ul style="list-style-type: none"> <li>To set the SMTP sever address for transmission used for the CS Remote Care.</li> </ul>
Use	<ul style="list-style-type: none"> <li>To set the SMTP server address.</li> <li>SMTP server address can be set by the IP address or the domain name.</li> </ul>
Setting/ Procedure	<p>&lt;Input IP Address&gt;</p> <ul style="list-style-type: none"> <li>IP address version 4 format [0 to 255].[0 to 255].[0 to 255].[0 to 255]</li> </ul> <p>&lt;Input FQDN&gt;</p> <ul style="list-style-type: none"> <li>Enter the domain name.</li> </ul>



**10.7.9 List of the CS Remote Care error code****A. When connecting by modem**

Error code	Error	Solution
0001	The line is busy (Busy detection)	<ul style="list-style-type: none"> <li>• Transmit again manually.</li> </ul>
0002	Failure of the Modem default setting at transmitting (When the transmission completes with modem initial setting failed)	<ul style="list-style-type: none"> <li>• Check if the power of the modem is ON.</li> <li>• Check the connecting condition between the modem and the main body.</li> </ul>
0003	Timeout of CONNECT at transmitting (No response to ATD)	<ul style="list-style-type: none"> <li>• Transmit again manually</li> <li>• Check if the power of the modem is ON.</li> <li>• Check the connecting condition between the modem and the main body.</li> </ul>
0005	Timeout of CONNECT at receiving (No response to ATA)	<ul style="list-style-type: none"> <li>• Check if the power of the modem is ON.</li> <li>• Check the connecting condition between the modem and the main body.</li> </ul>
0006	Shut down of the data modem line (Host) (Carrier OFF is detected)	<ul style="list-style-type: none"> <li>• No solution, because the line is shut down at the host side.</li> </ul>
0008	Timeout of start request telegram delivery (Start request telegram is not delivered after line connection)	<ul style="list-style-type: none"> <li>• Transmit again manually.</li> </ul>
0009	Timeout of finish request telegram delivery (Finish request telegram is not delivered (Start of shut down).)	<ul style="list-style-type: none"> <li>• Transmit again manually.</li> </ul>
000A	Receiving rejection (Receiving is made when the main body is set to reject receiving.)	<ul style="list-style-type: none"> <li>• Check the setting condition of the host side.</li> <li>• Check the setting condition of the main body side.</li> </ul>
000B	RS232C driver over run (When the modem detects over run.)	<ul style="list-style-type: none"> <li>• If the same error is detected several times, turn the modem power OFF and ON.</li> </ul>
000C	If the same error is detected several times, turn the modem power OFF and ON.	<ul style="list-style-type: none"> <li>• If the same error is detected several times, turn the modem power OFF and ON.</li> </ul>
000D	Break Interrupt (BI) indicator (When the modem detects Break Interrupt (BI) indicator.)	<ul style="list-style-type: none"> <li>• If the same error is detected several times, turn the modem power OFF and ON.</li> </ul>
0011	Baud rate ERROR (When selected baud rate is out of the specification (9600 bps to 38400 bps).)	<ul style="list-style-type: none"> <li>• Check the baud rate of the software DipSW.</li> </ul>
0018	Machine ID has already been registered (Request telegram 2 (SET-UP) comes from the main body that has already registered machine ID.)	<ul style="list-style-type: none"> <li>• Set the initial registrations again for all including the host side.</li> </ul>
0019	Center ID error (Center ID of the host is not identical with the one of start request telegram.)	<ul style="list-style-type: none"> <li>• Check center ID setting of the main body side.</li> <li>• Check center ID setting of the main body side.</li> </ul>

Error code	Error	Solution
001A	Device ID inconsistency (Device ID of the host is not identical with the one of start request telegram.)	<ul style="list-style-type: none"> <li>• Check device ID setting of the main body side.</li> <li>• Check the setting of the host side.</li> </ul>
001B	Device ID unregistered (Request telegram 2 (Constant data transmitting, emergency call) comes from the main body that has not registered machine ID yet.)	<ul style="list-style-type: none"> <li>• Check device ID setting of the main body side.</li> <li>• Check the setting of the host side.</li> </ul>
001E	Impossible to change (during printing) (Setting cannot be changed because the setting change is made during the machine is printing or starts printing.)	<ul style="list-style-type: none"> <li>• Try again when the machine is not printing.</li> </ul>
0020	Timeout of telegram delivery (At waiting mode of telegram delivery the machine fails to receive the telegram in a given time.)	<ul style="list-style-type: none"> <li>• Try communication again.</li> </ul>
0027	Transmission / receiving collision (Receiving is detecting during transmitting processing)	<ul style="list-style-type: none"> <li>• Try communication again.</li> </ul>

**NOTE**

- **When a code other than the ones listed above is displayed, contact KMBT and inform the error code.**

**B. When connecting by e-mails**

Error code	Error	Solution
0001	Connection timeout during transmission	<ul style="list-style-type: none"> <li>Check the SMTP server on User side.</li> </ul>
0###	Transmission error ***: SMTP responding code (hexadecimal)	<ul style="list-style-type: none"> <li>Check the SMTP server on User side.</li> </ul>
0003	Connection timeout when receiving	<ul style="list-style-type: none"> <li>Check the POP3 server on User side.</li> </ul>
0005	Receiving error	<ul style="list-style-type: none"> <li>Check the POP3 server on User side.</li> </ul>
1030	Machine ID mismatching <ul style="list-style-type: none"> <li>Received an e-mail which tells that machine ID mismatches.</li> </ul>	<ul style="list-style-type: none"> <li>Check the machine ID setting.</li> <li>Check the machine ID setting on host side.</li> </ul>
1062	Modifying not available due to the copy job currently performing <ul style="list-style-type: none"> <li>When informing the host that it cannot be modified due to the copy job currently performing.</li> </ul>	<ul style="list-style-type: none"> <li>Ask the host to send another instruction mail for modifying.</li> </ul>
1081	Frame No. error <ul style="list-style-type: none"> <li>The last frame has not been received.</li> <li>There are missing frame No.</li> </ul>	<ul style="list-style-type: none"> <li>Check the status of the machine registration on host side.</li> </ul>
1084	Date expired <ul style="list-style-type: none"> <li>Expiration date for data modification command has passed.</li> </ul>	<ul style="list-style-type: none"> <li>Ask the host to send another instruction mail for modifying.</li> </ul>
1092	Received an error mail when center setup is not complete	<ul style="list-style-type: none"> <li>Check the status of the machine registration on host side.</li> </ul>
2039	Socket is not connected. <ul style="list-style-type: none"> <li>LAN cable on the copier side is detached.</li> </ul>	<ul style="list-style-type: none"> <li>Check the SMTP server and POP3 server on user side.</li> </ul>
203E	Network is down. <ul style="list-style-type: none"> <li>LAN cable on the copier side is detached.</li> </ul>	<ul style="list-style-type: none"> <li>Check the connection between the copier on the user's side and the network connector.</li> <li>Check the network environment on the user's side.</li> </ul>
3000	POP3_AUTHORIZATION_ERR	<ul style="list-style-type: none"> <li>Check the POP3 server environment on user's side.</li> </ul>
3001	POP3_TRANSACTION_ERR	<ul style="list-style-type: none"> <li>Check the POP3 server environment on user's side.</li> </ul>
3002	POP3_CONNECT_ERR	<ul style="list-style-type: none"> <li>Check the POP3 server environment on user's side.</li> </ul>
3003	POP3_TIMEOUT_ERR	<ul style="list-style-type: none"> <li>Check the POP3 server environment on user's side.</li> </ul>
3004	POP3_FORMAT_ERR	<ul style="list-style-type: none"> <li>Check the POP3 server environment on user's side.</li> </ul>
3005	POP3_MEMORY_ERR	<ul style="list-style-type: none"> <li>Check the POP3 server environment on user's side.</li> </ul>
3006	POP3_JOBID_ERR	<ul style="list-style-type: none"> <li>Check the POP3 server environment on user's side.</li> </ul>
3007	POP3_NO_DATA_ERR	<ul style="list-style-type: none"> <li>Check the POP3 server environment on user's side.</li> </ul>

Error code	Error	Solution
3008	POP3_DELETE_FAIL_ERR	<ul style="list-style-type: none"> <li>Check the POP3 server environment on user's side.</li> </ul>
3009	POP3_MAILBOX_FULL	<ul style="list-style-type: none"> <li>Check the POP3 server environment on user's side.</li> </ul>
4103	Not ready <ul style="list-style-type: none"> <li>Tried to transmit or receive an e-mail when the machine was not yet in the e-mail receiving status after power was turned ON.</li> </ul>	<ul style="list-style-type: none"> <li>Wait for a while and try transmitting again.</li> </ul>
4104	SMTP channel not ready	<ul style="list-style-type: none"> <li>Wait for a while and try transmitting again.</li> </ul>
4105	POP3 channel not ready	<ul style="list-style-type: none"> <li>Wait for a while and try transmitting again.</li> </ul>
4106	Not Ready other than the ones listed above.	<ul style="list-style-type: none"> <li>Wait for a while and try transmitting again.</li> </ul>

**NOTE**

- When a code other than the ones listed above is displayed, contact KMBT and inform the error code.

**C. When connecting by Fax modem**

Error code	Error	Solution
T50	Host terminal ID not correct	<ul style="list-style-type: none"> <li>Check the telephone number set for host.</li> </ul>
R80	Serial number received from the host not correct.	<ul style="list-style-type: none"> <li>Check the status of the Machine registration on host side.</li> </ul>
R81	Disconnection of writing instruction from host during machine is running.	<ul style="list-style-type: none"> <li>Wait for a while and try transmitting again.</li> </ul>
R82	Disconnection of FAX-CSRC instruction when FASX-CSRC is not allowed.	<ul style="list-style-type: none"> <li>Check the status of the Machine registration on host side.</li> </ul>
R83	Host command error.	<ul style="list-style-type: none"> <li>Contact KMBT and inform the error code.</li> </ul>
R84	NVRAM writing error.	<ul style="list-style-type: none"> <li>Contact KMBT and inform the error code.</li> </ul>

**NOTE**

- When a code other than the ones listed above is displayed, see the FK-502 Service Manual.

### 10.7.10 Troubleshooting for CS Remote Care

If communication is not done properly, check the condition by following the procedures shown below.

- Shift the screen in the order of [Service Mode] → [CS Remote Care] → [Detail Setting].  
At this time, in the cases of initial transmitting / administrator transmitting / maintenance start transmitting / maintenance finish transmitting, the communication result will be displayed at the top of the screen.

\* For the communication result, the following message will be displayed based on its success or failure.

Display of communication result	Cause	Solution
Communicating	—	—
Communication trouble with the center	Although the machine tries to communicate with the center, there is any trouble and the communication completes unsuccessfully.	<ul style="list-style-type: none"> <li>See the list of error message and confirm the corresponding point. <a href="#">See P.383</a></li> </ul>
Complete successfully	—	—
Modem trouble	Although the machine tries to communicate with the center, there is any trouble in the modem.	<ul style="list-style-type: none"> <li>Check if the power of modem in ON.</li> <li>Check if there is any problem in connection between the modem and the main body.</li> </ul>
Busy line	Although the machine tries to communicate with the center, the line to the center is busy.	<ul style="list-style-type: none"> <li>Communicate with the center again.</li> </ul>
No response	Although the machine tries to communicate with the center, there is no response from the center.	<ul style="list-style-type: none"> <li>Communicate with the center again.</li> <li>Check the communication environment of the center side.</li> </ul>



## 10.8 System 1

### 10.8.1 Marketing Area

Functions	<ul style="list-style-type: none"> <li>To make the various settings (language, paper size, fixed zoom ratios, etc.) according to the applicable marketing area.</li> </ul>														
Use	<ul style="list-style-type: none"> <li>Upon setup.</li> </ul>														
Setting/ Procedure	<p>&lt;Marketing Area&gt;</p> <ul style="list-style-type: none"> <li>Select the applicable marketing area and touch [END] to set the marketing area.</li> </ul> <p style="text-align: center;">           JAPAN            US            Europe            Others1   Others2   Others3   Others4         </p> <p>* These are the languages that can be selected on the Utility screen according to different marketing area settings:</p> <table border="1" style="margin-left: auto; margin-right: auto;"> <tr> <td>Japan</td> <td>English, Japanese</td> </tr> <tr> <td>US</td> <td>English, French, Spanish, Japanese</td> </tr> <tr> <td>Europe</td> <td>English, French, Italian, German, Spanish, Japanese</td> </tr> <tr> <td>Others1</td> <td>English, French, Spanish, Japanese</td> </tr> <tr> <td>Others2</td> <td>English, French, Spanish, Traditional Chinese, Hungle</td> </tr> <tr> <td>Others3</td> <td>English, Simplified Chinese</td> </tr> <tr> <td>Others4</td> <td>English, Traditional Chinese</td> </tr> </table> <p>&lt;Fax Target&gt;</p> <ol style="list-style-type: none"> <li>Touch the [Fax Target].</li> <li>Select the applicable marketing area using [+ ] and [- ] keys, and touch [END].</li> </ol>	Japan	English, Japanese	US	English, French, Spanish, Japanese	Europe	English, French, Italian, German, Spanish, Japanese	Others1	English, French, Spanish, Japanese	Others2	English, French, Spanish, Traditional Chinese, Hungle	Others3	English, Simplified Chinese	Others4	English, Traditional Chinese
Japan	English, Japanese														
US	English, French, Spanish, Japanese														
Europe	English, French, Italian, German, Spanish, Japanese														
Others1	English, French, Spanish, Japanese														
Others2	English, French, Spanish, Traditional Chinese, Hungle														
Others3	English, Simplified Chinese														
Others4	English, Traditional Chinese														

### 10.8.2 Tel/Fax Number

Functions	<ul style="list-style-type: none"> <li>To enter the tel/fax number of the service contact that will appear on the control panel when a malfunction occurs in the machine.</li> </ul>
Use	<ul style="list-style-type: none"> <li>Upon setup.</li> </ul>
Setting/ Procedure	<ul style="list-style-type: none"> <li>Enter the tel/fax number (19 digits) from the 10-key pad.</li> <li>Use Interrupt key to enter “-.”</li> </ul>

### 10.8.3 Serial Number

Functions	<ul style="list-style-type: none"> <li>To register the serial numbers of the machine and options.</li> <li>The numbers will be printed on the list output.</li> <li>To use the serial number as Machine ID during CS Remote Care communication.</li> </ul>
Use	<ul style="list-style-type: none"> <li>Upon setup.</li> </ul> <p><b>NOTE</b></p> <ul style="list-style-type: none"> <li><b>When main power switch was turned ON while the serial No. was not entered, the message to require entering the serial No. will be displayed.</b></li> <li><b>Do not change the serial number registered in the machine. If memory data is lost and entering the serial number is required, enter the original correct serial number.</b></li> </ul> <p><b>Be careful to enter the correct serial number since characters other than alphanumeric can be also entered. CSRC communication is not available if a wrong serial number is entered.</b></p>
Setting/ Procedure	<ul style="list-style-type: none"> <li>Type the serial numbers.</li> </ul> <p>Printer, Scanner, ADF, LCT, Sorter/FN, Duplex, Vendor, Fax1, Fax2</p>

### 10.8.4 No Sleep

Functions	<ul style="list-style-type: none"> <li>To display the option of "OFF" for the sleep mode setting screen available from administrator settings.</li> </ul>
Use	<ul style="list-style-type: none"> <li>To display the option of "OFF" for the sleep mode setting.</li> </ul> <p><b>NOTE</b></p> <ul style="list-style-type: none"> <li><b>The sleep mode will begin in 48 hours even if it sets it to "OFF."</b></li> </ul>
Setting/ Procedure	<ul style="list-style-type: none"> <li>The default setting is "Prohibit."</li> </ul> <p style="text-align: center;">Permit <span style="float: right;">"Prohibit"</span></p>

### 10.8.5 Foolscap Size Setting

Functions	<ul style="list-style-type: none"> <li>To set the size for foolscap paper.</li> </ul>
Use	<ul style="list-style-type: none"> <li>Upon setup.</li> <li>To change the size for foolscap paper.</li> </ul>
Setting/ Procedure	<ul style="list-style-type: none"> <li>Select the size from among the following five.</li> </ul> <p style="text-align: center;">220 x 330 mm    8 1/2 x 13    8 1/4 x 13    8 1/8 x 13 1/4    8 x 13</p>

### 10.8.6 Original Size Detection

Functions	<ul style="list-style-type: none"> <li>To change the document size detection table.</li> </ul>
Use	<ul style="list-style-type: none"> <li>Use to change the setting for the document size detection table.</li> </ul> <p>Copy Glass: To change the size detection table for the document glass.</p>
Setting/ Procedure	<p>&lt;Copy Glass&gt;</p> <ul style="list-style-type: none"> <li>The default setting is "Table1."</li> </ul> <p style="text-align: center;">"Table1" <span style="float: right;">Table2</span></p> <p><b>NOTE</b></p> <ul style="list-style-type: none"> <li><b>Table 2 can be set only when original size detection 2 sensor is being mounted.</b></li> </ul>

### 10.8.7 Install Date

Functions	<ul style="list-style-type: none"> <li>To register the date the main body was installed.</li> </ul>
Use	<ul style="list-style-type: none"> <li>Upon setup.</li> </ul>
Setting/ Procedure	<ol style="list-style-type: none"> <li>Call the Service Mode on the screen.</li> <li>Select the key as follows. [System 1] → [Install Date].</li> <li>Enter the date (Year 4 digit → Month 2 digit → date 2 digit) from the 10-key pad.</li> <li>Touch [Entry] to set the date of installation.</li> </ol>

### 10.8.8 Initialization

#### A. Data Clear

Functions	<ul style="list-style-type: none"> <li>To initialize the setting data.</li> </ul>
Use	<ul style="list-style-type: none"> <li>To clears the setting data.</li> </ul> <p>For details on items to be cleared, see "Contents to be cleared by reset function." See P.450</p> <p><b>NOTE</b></p> <ul style="list-style-type: none"> <li><b>When removing or installing the hard disk after registering the data below, be sure to clear the data.</b> <b>Referring data: One-touch registration, user authentication/account track.</b></li> </ul>
Setting/ Procedure	<ol style="list-style-type: none"> <li>Call the Service Mode to the screen.</li> <li>Select the key as follows. [System 1] → [Initialization] → [Data clear].</li> <li>Press the Start key.</li> <li>When [OK] is displayed, turn off the main power switch and turn it on again more than 10 seconds after.</li> </ol>

#### B. System Error Clear

Functions	<ul style="list-style-type: none"> <li>To reset the trouble data.</li> </ul>
Use	<ul style="list-style-type: none"> <li>Use to clear the [Jam], [Trouble], [Error] displays, and other improper displays.</li> </ul> <p>For details on items to be cleared, see "Contents to be cleared by reset function." See P.450</p>
Setting/ Procedure	<ol style="list-style-type: none"> <li>Call the Service Mode to the screen.</li> <li>Select the key as follows. [System 1] → [Initialization] → [System Error Clear].</li> <li>Press the Start key.</li> <li>When [OK] is displayed, turn off the main power switch and turn it on again more than 10 seconds after.</li> </ol>

**10.8.9 Trouble Isolation**

Functions	<ul style="list-style-type: none"> <li>Individual units and options have a set or unset setting for the trouble isolation function.</li> </ul>
Use	<ul style="list-style-type: none"> <li>When a problem occurs, this function enables the continuous use of the units that are not affected by separately controlling them and isolating other units that have a problem.</li> <li>The machine isolates only units that have a “set” setting.</li> </ul> <p><b>NOTE</b></p> <ul style="list-style-type: none"> <li><b>The malfunction detection mechanism is not applied to units and options that are being isolated.</b></li> <li>This function can be selected for the following units and options. Tray 1, Tray 2, Tray 3, LCT, manual, Half-Fold/Tri-Fold Center Stapling, Staple and Scanner.</li> <li>Though trouble isolation is not selected, if the specified malfunctions occur on the above listed units or options, an alert screen appears and asks users whether to isolate the units or options where malfunction occurs. See the “Trouble shooting” section for the corresponding trouble codes. <a href="#">See P.486</a></li> </ul>
Setting/ Procedure	<ul style="list-style-type: none"> <li>The default setting is Unset for individual units and options.   <div style="display: flex; justify-content: space-around;"> <span>Set</span> <span>“Unset”</span> </div> </li> <li>After changing the setting, touch [Decision] and turn the main power switch OFF and ON to make the new setting effective.</li> </ul>

bizhub C353/C253/C203

Adjustment / Setting

**10.8.10 IU Life Setting**

Functions	<ul style="list-style-type: none"> <li>To set the life threshold for imaging units.</li> </ul>
Use	<ul style="list-style-type: none"> <li>Use this setting when a gap appears between the actual life value of imaging unit and the life specification value due to the way * a machine is used.</li> <li>Comparing the PC drum rotation time with the PC drum rotation time calculated based on the number of printed pages, the machine detects the end of unit life using the one that reaches the life specification value earlier. This setting aims to extend the life threshold for the PC drum rotation time and achieve a longer imaging unit life.</li> </ul> <p>Normal : detects the end of life when the life specification value is reached.</p> <p>Long (Suspend) : detects the end of life when a value greater (longer) than the life specification value is reached.</p> <p>*The product specification value is determined based on what types of printing are made on the machine. If the types of printing made on the machine are different from the specified printing conditions, the life value of the imaging unit tends to be different from the life specification value. See conditions for life specification values in the service manual titled maintenance for more information on printing conditions. <a href="#">See P.21</a></p> <p><b>NOTE</b></p> <ul style="list-style-type: none"> <li>The options that can be selected are [Normal] / [Suspend], if the firmware of function enhanced version 1 or later is mounted.</li> <li>When “Long (Suspend)” is selected, images printed after the life specification value is out of guarantee. The life counter value of imaging unit is accessed from [Service Mode] → [Counter] → [Life].</li> <li>Before making this setting, be sure to check that the machine does not display any message that warns each of imaging units, fusing unit, or image transfer belt unit reaches their life value.</li> </ul>
Setting/ Procedure	<ul style="list-style-type: none"> <li>The default setting is Normal.</li> </ul> <p style="text-align: center;">“Normal” <span style="float: right;">Long (Suspend)</span></p> <p><b>NOTE</b></p> <ul style="list-style-type: none"> <li>When the setting has been changed, turn off the sub power switch and turn it on again.</li> </ul>

bizhub C353/C253/C203

Adjustment / Setting

**10.8.11 Change Warm Up Time**

Functions	<ul style="list-style-type: none"> <li>To change the warm up time.</li> </ul>																	
Use	<ul style="list-style-type: none"> <li>With the warm-up time set to mode 1, if monochrome printing is made immediately after a warm-up cycle and a paper curl problem occurs, change the setting to mode2.</li> <li>With the use of recycled or low quality paper, if a paper curl problem or other paper curl related failures occur immediately after a normal warm-up cycle, set the setting to mode 3 or mode 4. Other paper curl related failures include jam, paper ejection failure, and punch/staple/fold position failure.</li> </ul> <p>The following table shows the warm-up time (normal warm-up) in each mode.</p> <table border="1" data-bbox="283 384 986 643"> <thead> <tr> <th></th> <th>bizhub C353</th> <th>bizhub C253/C203</th> </tr> </thead> <tbody> <tr> <td>Mode 1</td> <td>Monochrome: 30 sec. Color: 41 sec.</td> <td>Monochrome: 27 sec. Color: 37 sec.</td> </tr> <tr> <td>Mode 2</td> <td>Monochrome: 41 sec. Color: 41 sec.</td> <td>Monochrome: 40 sec. Color: 40 sec.</td> </tr> <tr> <td>Mode 3</td> <td>Monochrome: 41 sec. Color: 41 sec.</td> <td>Monochrome: 40 sec. Color: 40 sec.</td> </tr> <tr> <td>Mode 4</td> <td>Monochrome: 130 sec. Color: 130 sec.</td> <td>Monochrome: 140 sec. Color: 140 sec.</td> </tr> </tbody> </table>				bizhub C353	bizhub C253/C203	Mode 1	Monochrome: 30 sec. Color: 41 sec.	Monochrome: 27 sec. Color: 37 sec.	Mode 2	Monochrome: 41 sec. Color: 41 sec.	Monochrome: 40 sec. Color: 40 sec.	Mode 3	Monochrome: 41 sec. Color: 41 sec.	Monochrome: 40 sec. Color: 40 sec.	Mode 4	Monochrome: 130 sec. Color: 130 sec.	Monochrome: 140 sec. Color: 140 sec.
	bizhub C353	bizhub C253/C203																
Mode 1	Monochrome: 30 sec. Color: 41 sec.	Monochrome: 27 sec. Color: 37 sec.																
Mode 2	Monochrome: 41 sec. Color: 41 sec.	Monochrome: 40 sec. Color: 40 sec.																
Mode 3	Monochrome: 41 sec. Color: 41 sec.	Monochrome: 40 sec. Color: 40 sec.																
Mode 4	Monochrome: 130 sec. Color: 130 sec.	Monochrome: 140 sec. Color: 140 sec.																
Setting/ Procedure	<ul style="list-style-type: none"> <li>The default setting is Mode 1.</li> </ul> <p style="text-align: center;"> <span style="margin-right: 40px;">"Mode 1"</span> <span style="margin-right: 40px;">Mode 2</span> <span style="margin-right: 40px;">Mode3</span> <span>Mode4</span> </p>																	

bizhub C353/C253/C203

Adjustment / Setting

10.8.12 Machine State LED Setting

Functions	<ul style="list-style-type: none"> <li>To set how to display main body statuses on the machine state LED (state display lamp, paper empty lamp).</li> <li>Each of Type1 and Type2 has the following LED display forms.</li> </ul>																																																			
Use	<table border="1" style="width: 100%; border-collapse: collapse;"> <thead> <tr> <th colspan="2" style="text-align: center;">Machine State LED Setting</th> <th style="text-align: center;">Type1</th> <th style="text-align: center;">Type2</th> </tr> </thead> <tbody> <tr> <td rowspan="5" style="vertical-align: middle;">Warning statuses</td> <td>Attention                             <ul style="list-style-type: none"> <li>Toner supply door open</li> <li>Improper toner cartridge placement</li> </ul> </td> <td style="text-align: center;">Blinking</td> <td style="text-align: center;">Blinking</td> </tr> <tr> <td>Near life</td> <td style="text-align: center;">Blinking</td> <td style="text-align: center;">Unlit</td> </tr> <tr> <td>Alert code</td> <td style="text-align: center;">Unlit</td> <td style="text-align: center;">Unlit</td> </tr> <tr> <td>Trouble isolation</td> <td style="text-align: center;">Blinking</td> <td style="text-align: center;">Blinking</td> </tr> <tr> <td>Fatal error                             <ul style="list-style-type: none"> <li>Trouble code</li> <li>Jam</li> <li>Door opened</li> <li>Life stop</li> </ul> </td> <td style="text-align: center;">Lit</td> <td style="text-align: center;">Lit</td> </tr> <tr> <td rowspan="4" style="vertical-align: middle;">Amount of paper remaining (Tray 1 and 2)</td> <td>100 % to 66 % of paper remaining</td> <td style="text-align: center;">Unlit</td> <td style="text-align: center;">Unlit</td> </tr> <tr> <td>Near empty</td> <td style="text-align: center;">Blinking</td> <td style="text-align: center;">Unlit</td> </tr> <tr> <td>Empty</td> <td style="text-align: center;">Lit</td> <td style="text-align: center;">Lit</td> </tr> <tr> <td>Being lifted up Door opened or closed</td> <td style="text-align: center;">Unlit</td> <td style="text-align: center;">Unlit</td> </tr> <tr> <td rowspan="5" style="vertical-align: middle;">Amount of paper remaining (Tray 3 and 4, LCT)</td> <td>100 % to 33 % paper remaining</td> <td style="text-align: center;">Unlit</td> <td style="text-align: center;">Unlit</td> </tr> <tr> <td>33 % to near empty</td> <td style="text-align: center;">Blinking</td> <td style="text-align: center;">Unlit</td> </tr> <tr> <td>Near empty</td> <td style="text-align: center;">Blinking</td> <td style="text-align: center;">Unlit</td> </tr> <tr> <td>Empty</td> <td style="text-align: center;">Lit</td> <td style="text-align: center;">Lit</td> </tr> <tr> <td>Being lifted up Door opened or closed</td> <td style="text-align: center;">Unlit</td> <td style="text-align: center;">Unlit</td> </tr> </tbody> </table>			Machine State LED Setting		Type1	Type2	Warning statuses	Attention <ul style="list-style-type: none"> <li>Toner supply door open</li> <li>Improper toner cartridge placement</li> </ul>	Blinking	Blinking	Near life	Blinking	Unlit	Alert code	Unlit	Unlit	Trouble isolation	Blinking	Blinking	Fatal error <ul style="list-style-type: none"> <li>Trouble code</li> <li>Jam</li> <li>Door opened</li> <li>Life stop</li> </ul>	Lit	Lit	Amount of paper remaining (Tray 1 and 2)	100 % to 66 % of paper remaining	Unlit	Unlit	Near empty	Blinking	Unlit	Empty	Lit	Lit	Being lifted up Door opened or closed	Unlit	Unlit	Amount of paper remaining (Tray 3 and 4, LCT)	100 % to 33 % paper remaining	Unlit	Unlit	33 % to near empty	Blinking	Unlit	Near empty	Blinking	Unlit	Empty	Lit	Lit	Being lifted up Door opened or closed	Unlit	Unlit
Machine State LED Setting		Type1	Type2																																																	
Warning statuses	Attention <ul style="list-style-type: none"> <li>Toner supply door open</li> <li>Improper toner cartridge placement</li> </ul>	Blinking	Blinking																																																	
	Near life	Blinking	Unlit																																																	
	Alert code	Unlit	Unlit																																																	
	Trouble isolation	Blinking	Blinking																																																	
	Fatal error <ul style="list-style-type: none"> <li>Trouble code</li> <li>Jam</li> <li>Door opened</li> <li>Life stop</li> </ul>	Lit	Lit																																																	
Amount of paper remaining (Tray 1 and 2)	100 % to 66 % of paper remaining	Unlit	Unlit																																																	
	Near empty	Blinking	Unlit																																																	
	Empty	Lit	Lit																																																	
	Being lifted up Door opened or closed	Unlit	Unlit																																																	
Amount of paper remaining (Tray 3 and 4, LCT)	100 % to 33 % paper remaining	Unlit	Unlit																																																	
	33 % to near empty	Blinking	Unlit																																																	
	Near empty	Blinking	Unlit																																																	
	Empty	Lit	Lit																																																	
	Being lifted up Door opened or closed	Unlit	Unlit																																																	
Setting/ Procedure	<ul style="list-style-type: none"> <li>Each default setting is Type1.</li> </ul> <p style="text-align: center;">"Type 1" <span style="margin-left: 200px;">Type 2</span></p> <p><b>NOTE</b></p> <ul style="list-style-type: none"> <li><b>[Type 2] is the default setting, if the firmware of function enhanced version 1 or later is mounted.</b></li> </ul>																																																			

bizhub C353/C253/C203

Adjustment / Setting



## 10.9 System 2

### 10.9.1 HDD

Functions	<ul style="list-style-type: none"> <li>Not used.</li> </ul>
Use	
Setting/ Procedure	

### 10.9.2 Image Controller Setting



Functions	<ul style="list-style-type: none"> <li>To set the type of the controller.</li> <li>[Peripheral Mode] appears when [Others] is selected.</li> </ul>
Use	<ul style="list-style-type: none"> <li>When setting up the controller.</li> </ul>
Setting/ Procedure	<p>Image Controller Setting</p> <ul style="list-style-type: none"> <li>Select the controller to be used.                     <ul style="list-style-type: none"> <li>“Controller 0” : The standard controller is used.</li> <li>Controller 1 : The optional image controller IC-409 is used.</li> <li>Controller 2 : undefined.</li> <li>Controller 3 : undefined.</li> <li>Others : undefined.</li> </ul> </li> </ul> <p>Peripheral Mode</p> <ul style="list-style-type: none"> <li>This setting is available when the Image Controller Setting is set to “Others.”                     <ul style="list-style-type: none"> <li>Mode 1: undefined.</li> <li>Mode 2: undefined.</li> <li>Mode 3: undefined.</li> </ul> </li> </ul> <p><b>NOTE</b></p> <ul style="list-style-type: none"> <li><b>When the following setting is “ON”, this setting should be set to “Controller 0”.</b>                      [Administrator Settings] → [Security Settings] → [Enhanced Security Mode]  <b>When [Enhanced Security Mode] is set to “ON”, this setting cannot be changed.</b></li> <li><b>After changing setting, make sure to turn off the main power switch and turn it on again more than 10 seconds after.</b></li> </ul> <p><b>Note on returning the setting from “Controller 1” to “Controller 0”.</b></p> <ul style="list-style-type: none"> <li>Selecting “Controller 0” will initialize the following settings made while “Controller 1” was selected. Reset the following items as necessary when using the internal standard controller.</li> </ul> <p>&lt;Control panel on the machine&gt;</p> <ul style="list-style-type: none"> <li>Setting items included in [Network Setting] available from [Administrator Setting]. (Except [Status Notification Setting] and [Prefix/Suffix Setting] available from the following setting. [Administrator Settings] → [Network Settings] → [Detail Settings].)</li> <li>The following setting                      [Administrator Settings] → [User Authentication /Account Track] →[General Settings] → [External Server]</li> <li>The following setting                      [Administrator Settings] → [System Connection] → [IS OpenAPI Setting]</li> <li>Mailbox Destination (scan)</li> <li>Information on the original specified by the program destination</li> </ul> <p>&lt;Page Scope Web Connection&gt;</p> <ul style="list-style-type: none"> <li>SSL/TLS</li> </ul>



### 10.9.3 Option Board Status

Functions	<ul style="list-style-type: none"> <li>To set when the optional fax mount kit, scan accelerator is mounted.</li> </ul>									
Use	<ul style="list-style-type: none"> <li>Use when setting up the optional fax mount kit, scan accelerator is mounted.</li> </ul>									
Setting/ Procedure	<ul style="list-style-type: none"> <li>Setting modes are Fax (circuit 1), Fax (circuit 2) and JPEG.</li> <li>The default settings are "Unset."</li> </ul> <table style="margin-left: 40px;"> <tr> <td>Fax (circuit 1)</td> <td>: Set</td> <td>"Unset"</td> </tr> <tr> <td>Fax (circuit 2)</td> <td>: Set</td> <td>"Unset"</td> </tr> <tr> <td>JPEG</td> <td>: Set</td> <td>"Unset"</td> </tr> </table> <p><b>NOTE</b></p> <ul style="list-style-type: none"> <li>When the setting has been changed, turn off the main power switch and turn it on again more than 10 seconds after.</li> </ul>	Fax (circuit 1)	: Set	"Unset"	Fax (circuit 2)	: Set	"Unset"	JPEG	: Set	"Unset"
Fax (circuit 1)	: Set	"Unset"								
Fax (circuit 2)	: Set	"Unset"								
JPEG	: Set	"Unset"								

### 10.9.4 Consumable Life Reminder

Functions	<ul style="list-style-type: none"> <li>To select whether or not to give the display of PM parts lifetime</li> </ul> <p>PM parts lifetime display: An entire screen warning is given when the service life of a specific unit has been reached, prompting the user to replace the part.</p> <ul style="list-style-type: none"> <li>Applicable units: Transfer belt unit, fusing unit, imaging unit (C, M, Y, K)</li> </ul>		
Use	<ul style="list-style-type: none"> <li>Use to select not to give the display of PM parts lifetime.</li> </ul>		
Setting/ Procedure	<ul style="list-style-type: none"> <li>The default setting is "Yes."</li> </ul> <table style="margin-left: 40px;"> <tr> <td>"Yes"</td> <td>No</td> </tr> </table>	"Yes"	No
"Yes"	No		

### 10.9.5 Unit Change

Functions	<ul style="list-style-type: none"> <li>To select who is to replace a unit.</li> <li>When the unit life arrives, the warning display is intended for the specific person who is going to replace the unit. When "User" is selected : Printing is inhibited. When "Service" is selected: Life warning.</li> </ul>																		
Use	<ul style="list-style-type: none"> <li>Upon setup</li> </ul>																		
Setting/ Procedure	<p>&lt;Unit Change&gt;</p> <ul style="list-style-type: none"> <li>The following are the default settings:</li> </ul> <table style="margin-left: 40px;"> <tr> <td></td> <td>US, Japan, Others 4</td> <td>Europe, Others1/2/3</td> </tr> <tr> <td>Toner Cartridge</td> <td>: "User" Service</td> <td>"User" Service</td> </tr> <tr> <td>Imaging Unit</td> <td>: User "Service"</td> <td>"User" Service</td> </tr> <tr> <td>Waste Toner Box</td> <td>: User "Service"</td> <td>"User" Service</td> </tr> <tr> <td>Punch Dust Box</td> <td>: User "Service"</td> <td>"User" Service</td> </tr> </table> <p>&lt;Warning Display&gt;</p> <table style="margin-left: 40px;"> <tr> <td>Toner Near Empty</td> <td>: "Yes"</td> <td>No</td> </tr> </table>		US, Japan, Others 4	Europe, Others1/2/3	Toner Cartridge	: "User" Service	"User" Service	Imaging Unit	: User "Service"	"User" Service	Waste Toner Box	: User "Service"	"User" Service	Punch Dust Box	: User "Service"	"User" Service	Toner Near Empty	: "Yes"	No
	US, Japan, Others 4	Europe, Others1/2/3																	
Toner Cartridge	: "User" Service	"User" Service																	
Imaging Unit	: User "Service"	"User" Service																	
Waste Toner Box	: User "Service"	"User" Service																	
Punch Dust Box	: User "Service"	"User" Service																	
Toner Near Empty	: "Yes"	No																	

### 10.9.6 Software Switch Setting

Functions	<ul style="list-style-type: none"> <li>To set the operating characteristic of each function from software switch depending on what types of printing are normally made.</li> </ul>
Use	
Setting/ Procedure	<ol style="list-style-type: none"> <li>Touch [Software Switch Setting].</li> <li>Touch [Switch No.] and enter the intended switch number with the ten-key pad.</li> <li>Touch [Bit Assignment].</li> <li>Use [←] or [→] to select a bit. To set the bit, enter 0 or 1 with the ten-key pad.</li> <li>To set the bit in hex, touch [HEX Assignment] and use the ten-key pad and [A] to [F] keys to enter numbers and characters.</li> <li>Touch [Fix].</li> </ol>

#### A. Setting items in the software switch setting

##### (1) ACS mode control change

Functions	<ul style="list-style-type: none"> <li>To change the 1st image transfer roller pressure/retraction operation control in ACS mode.</li> </ul>
Use	<ul style="list-style-type: none"> <li>When a user makes mainly monochrome prints, selecting 01 may allow avoiding the PC drum wear-out caused by unnecessary rotation of color imaging units.</li> </ul> <p>HEX Assignment 00: The color print (pressed) position is set as the default position of the 1st image transfer roller. (Default setting)</p> <p>HEX Assignment 01: The monochrome print (retracted) position is set as the default position of the 1st image transfer roller.</p>
Setting/ Procedure	<ol style="list-style-type: none"> <li>Touch [Software Switch Setting].</li> <li>Touch [Switch No.] and enter "50" with the ten-key pad.</li> <li>Touch [HEX Assignment] and enter "00" or "01" with the 10-key pad.</li> <li>Touch [Fix].</li> </ol>

### 10.9.7 Scan Caribration

Functions	<ul style="list-style-type: none"> <li>To set whether to use the calibration adjustment value set prior to the shipping.</li> </ul>
Use	<ul style="list-style-type: none"> <li>To be used when CCD unit has been changed.</li> </ul> <p>After replacing the CCD unit, the default value needs to be set since the calibration value set for each unit changes to control the differences in reading performance on each scanner (CCD).</p> <ul style="list-style-type: none"> <li>The original calibration adjustment value can be disabled to address image failure and other problems caused by individual CCD performance difference.</li> </ul>
Setting/ Procedure	<ul style="list-style-type: none"> <li>The default setting is ON.</li> </ul> <p style="text-align: center;">"ON" <span style="margin-left: 200px;">OFF</span></p> <p><b>NOTE</b></p> <ul style="list-style-type: none"> <li><b>When the setting is changed, the function becomes available by turning the sub power switch OFF and ON again.</b></li> </ul>

### 10.9.8 LCT Paper Size Setting

Functions	<ul style="list-style-type: none"> <li>To set the paper size for the LCT.</li> </ul>
Use	<ul style="list-style-type: none"> <li>Use to change the paper size for the LCT (PC-405).</li> </ul>
Setting/ Procedure	<ul style="list-style-type: none"> <li>The default setting depends on the setting made for the applicable marketing area.</li> </ul> <p style="text-align: center;">A4 <span style="margin-left: 200px;">8<sup>1</sup>/<sub>2</sub> x 11</span></p>

**10.9.9 Line Mag Setting**

Functions	<ul style="list-style-type: none"> <li>To set whether to use the offset value which has been set prior to the shipping.</li> </ul>
Use	<ul style="list-style-type: none"> <li>To be used after replacing the CCD unit. After replacing the CCD unit, the default value needs to be set since the magnification offset value between the lines set for each unit changes to control the differences in reading performance on each scanner (CCD).</li> <li>The original offset value can be disabled to address image failure and other problems caused by individual CCD performance difference.</li> </ul>
Setting/ Procedure	<ul style="list-style-type: none"> <li>The default setting is ON.  "ON" <span style="float: right;">OFF</span></li> </ul> <p><b>NOTE</b></p> <ul style="list-style-type: none"> <li><b>When the setting is changed, the function becomes valid by turning the sub power switch OFF and ON again.</b></li> </ul>

### 10.9.10 Data Capture

Functions	<ul style="list-style-type: none"> <li>When an error occurs, it acquires the print job data in order to analyze the cause of the error.</li> </ul>
Use	<ul style="list-style-type: none"> <li>When an error occurs, this will be used to analyze the cause of the error according to the print job data.</li> </ul>
Setting/ Procedure	<p><b>NOTE</b></p> <ul style="list-style-type: none"> <li>The following conditions are necessary for this function.  <b>When selecting [Security Setting] → [Security Details] → [Print Data Capture] in Administrator Settings, [Allow] must be set. The hard disk must be mounted to the machine.</b>  <b>When selecting [Administrator Settings] → [Network Settings] → [FTP Settings], [FTP Server Settings: ON] must be set.</b></li> <li>This function is not available when the optional image controller IC-409 is mounted.</li> </ul> <ol style="list-style-type: none"> <li>Select [Service Mode] → [System 2], and touch [Data Capture]. Select [ON]. (While the Data Capture setting is [ON], the print job data from the PC will be stored in the hard disk.)</li> </ol> <p><b>NOTE</b></p> <ul style="list-style-type: none"> <li>The original offset value can be disabled to address image failure and other problems caused by individual CCD performance difference.</li> </ul> <ol style="list-style-type: none"> <li>Check the IP address of the machine.</li> <li>Connect the PC (Windows) and the machine with ethernet cable.</li> <li>Start the DOS command prompt of the PC, and specify the IP address of the machine to start FTP.</li> </ol> <div data-bbox="342 754 941 1023" data-label="Image"> <pre> Select Command Prompt - ftp Microsoft Windows 2000 [Version 5.00.2195] (C) Copyright 1985-2000 Microsoft Corp.  C:\&gt;ftp 172.16.0.225 Connected to 172.16.0.225. 220 KONICA MINOLTA FTP server ready. </pre> </div> <p style="text-align: right;">4037F3E538DA</p> <ol style="list-style-type: none"> <li>Input the user name and the password.        User name: capture        Password: sysadm</li> </ol> <div data-bbox="342 1166 941 1450" data-label="Image"> <pre> Select Command Prompt - ftp Microsoft Windows 2000 [Version 5.00.2195] (C) Copyright 1985-2000 Microsoft Corp.  C:\&gt;ftp 172.16.0.225 Connected to 172.16.0.225. 220 KONICA MINOLTA FTP server ready. User (172.16.0.225:(none)): capture 331 Password required for capture. Password: 230 User capture logged in. ftp&gt; </pre> </div> <p style="text-align: right;">4037F3E539DA</p>

Setting/  
Procedure

6. Using the "ls" command, display the list of the file available for capture.

```

Select Command Prompt - ftp
Microsoft Windows [Version 5.00.2195]
(C) Copyright 1985-2000 Microsoft Corp.

C:\>ftp 172.16.0.225
Connected to 172.16.0.225.
220 KOMICA MINOLTA FTP server ready.
User (172.16.0.225:(none)): capture
331 Password required for capture.
Password:
230 User capture logged in.
ftp>ls
200 PORT command successful.
150 Opening ASCII mode data connection for capture.
c716n.cpt
c708n.cpt
c709n.cpt
c712n.cpt
c714n.cpt
226 Transfer complete.
ftp: 50 bytes received in 0.00Seconds 50000.00Kbytes/sec.

```

4037F3E540DA

7. Using the "binary" command, set the File transfer mode to the binary transfer.

```

Select Command Prompt - ftp
ftp>ls
200 PORT command successful.
150 Opening ASCII mode data connection for capture.
c716n.cpt
c708n.cpt
c709n.cpt
c712n.cpt
c714n.cpt
226 Transfer complete.
ftp: 50 bytes received in 0.00Seconds 50000.00Kbytes/sec.
ftp> bi
200 Type set to I.
ftp>

```

4037F3E541DA

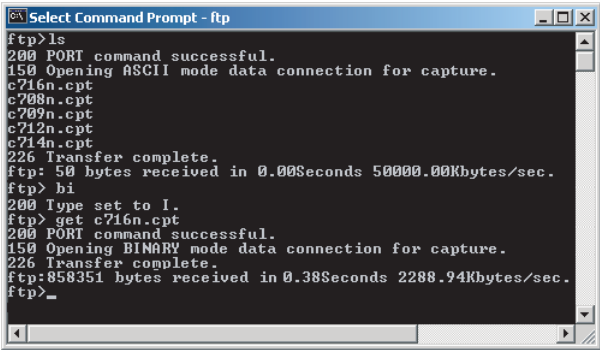
Setting/ Procedure	<p>8. Using the “get” command, transfer the data for capture to PC.</p>  <p style="text-align: right;">4037F3E542DA</p> <p>9. Finish the command prompt.</p> <p><b>NOTE</b></p> <ul style="list-style-type: none"> <li>• After receiving capture data, select [Administrator Settings] → [Security Settings] → [Security Details], and select [Restrict] for print data capture in order to delete the job data stored in the hard disk. When HDD Format or Overwrite Temporary Data is performed, job data is deleted.</li> </ul>
-----------------------	---

### 10.9.11 Split Line Detect. Setting

#### A. Prior Detection

Functions	<ul style="list-style-type: none"> <li>• To set the detection level for the pre-detection of stain on the ADF original glass.</li> </ul>
Use	<ul style="list-style-type: none"> <li>• Use when changing the setting for whether or not to detect the stain on the ADF original glass when opening/closing ADF as well as its detection level as the main/sub power being ON, recovering from the sleep/low power mode, etc.             <ul style="list-style-type: none"> <li>Not Set : Detection of stain on the glass will not be conducted.</li> <li>Low : Stain on the glass will not be detected easily.</li> <li>Normal : Normal level detection.</li> <li>High : Stain on the glass will easily be detected.</li> </ul> </li> </ul> <p><b>NOTE</b></p> <ul style="list-style-type: none"> <li>• Be aware that selecting “Not Set” and performing the pre-detection with the following setting will display “NG.” [Service Mode] → [Machine] → [Thin Line Prior Detection]</li> <li>• When “Not Set” is selected, the original glass cleaning operation after the job ends does not operate.</li> </ul>
Setting/ Procedure	<ul style="list-style-type: none"> <li>• The default setting is “Normal.”</li> </ul> <p style="text-align: center;">             Not Set                      Low                      “Normal”                      High         </p>

B. Warning Level

Functions	<ul style="list-style-type: none"> <li>To set how to display the warning when stain on the ADF original glass is detected.</li> </ul>
Use	<ul style="list-style-type: none"> <li>Use when changing the display of the warning which requests the cleaning of the stain on the glass detected by the pre-detection of the lines.           <ul style="list-style-type: none"> <li>0: Warning will not be displayed.</li> <li>1: Warning will be displayed by the maintenance mark. (warning code: D-1/D-2)</li> <li>2: Warning will be displayed on the message area on the basic screen.</li> <li>3: Warning will be displayed on all screens.</li> </ul> </li> </ul> <p><b>NOTE</b></p> <ul style="list-style-type: none"> <li><b>This setting is invalid when [Prior Detection] is set to "Not Set."</b></li> </ul>
Setting/ Procedure	<ul style="list-style-type: none"> <li>The default setting is 2.</li> </ul> <p style="text-align: center;">0                                  1                                  "2"                                  3</p>

C. Paper Passing Detection

Functions	<ul style="list-style-type: none"> <li>To set the operation for detection and removing operation of stain on the ADF original glass when feeding the original.</li> </ul>
Use	<ul style="list-style-type: none"> <li>Use when changing the operation for detection and removing operation of stain on the ADF original glass when feeding the original.           <ul style="list-style-type: none"> <li>0 : The glass will stop moving when the original is fed, and will not perform removing the stain.</li> <li>1 : The glass will move between originals when feeding the original.</li> <li>2 : When the original is fed, the glass will move while reading the original in order to remove the stain, and reduce the lines.</li> <li>3 to 6 : When the original is fed, the glass will move while reading the original in order to remove the stain. The lines will be reduced also by the image process control.               <ul style="list-style-type: none"> <li>The level 3, 4, 5, and 6 of the image process are set in this order with 3 being the most efficient in reducing the lines.</li> </ul> </li> </ul> </li> </ul> <p><b>NOTE</b></p> <ul style="list-style-type: none"> <li><b>When this function is used, an image quality problem might be occurred in the side effect by the image processing control according to the dirt condition of the original glass.</b></li> <li>When setting to "0" or "1", the setting area available for the administrator by the following setting will be restricted to "0 (Disable)" or "1 (Enable)."           <ul style="list-style-type: none"> <li>[Administrator Setting] → [System Setting] → [Expert Adjustment] → [Line Detection] → [Detection While Feeding Setting]</li> </ul> </li> </ul>
Setting/ Procedure	<ul style="list-style-type: none"> <li>The default setting is 1.</li> </ul> <p style="text-align: center;">0 to 6</p>

10.9.12 Stamp

Functions	<ul style="list-style-type: none"> <li>To set the mounting status of the optional stamp unit SP-501.</li> </ul>
Use	<ul style="list-style-type: none"> <li>To use when setting up the stamp unit SP-501.</li> </ul>
Setting/ Procedure	<ul style="list-style-type: none"> <li>The default setting is Unset.</li> </ul> <p style="text-align: center;">Set                                  "Unset"</p>

### 10.9.13 Network Fax Settings

Functions	<ul style="list-style-type: none"> <li>To set whether or not to use network fax function.</li> </ul>									
Use	<ul style="list-style-type: none"> <li>To use network fax function (IP address fax, internet fax).</li> <li>Selection will be available when each network fax function is set to "ON" in the following settings. [Administrator Settings] → [Network Settings] → [Network Fax Settings] → [Network Fax Function Settings]</li> </ul>									
Setting/ Procedure	<ul style="list-style-type: none"> <li>The default settings are OFF.</li> </ul> <table style="margin-left: 40px;"> <tr> <td>IP Address Fax :</td> <td>ON</td> <td>"OFF"</td> </tr> <tr> <td>SIP-Fax :</td> <td>Not Used</td> <td></td> </tr> <tr> <td>Internet Fax :</td> <td>ON</td> <td>"OFF"</td> </tr> </table>	IP Address Fax :	ON	"OFF"	SIP-Fax :	Not Used		Internet Fax :	ON	"OFF"
IP Address Fax :	ON	"OFF"								
SIP-Fax :	Not Used									
Internet Fax :	ON	"OFF"								



## 10.10 Counter

- The counter displays the counts of various counters to allow the technical representative to check or set as necessary.

### 10.10.1 Procedure

1. Touch [Counter] to show the counter menu.
2. Select the specific counter to be displayed.
3. To clear the counts of two or more counters within a group or across different groups at once, touch [Counter Reset], select the specific counters to be cleared, and touch [END]. Two or more counters can be selected.

### 10.10.2 Life

Functions	<ul style="list-style-type: none"> <li>• To check the number of hours or times each of the different maintenance parts has been used.</li> <li>• To clear the count of each counter.</li> </ul>
Use	<ul style="list-style-type: none"> <li>• When each of the maintenance parts is replaced.</li> </ul>
Setting/ Procedure	<ul style="list-style-type: none"> <li>• To clear the count of a counter, select the specific part and press the Clear key.</li> <li>• If a counter is cleared mistakenly, press the Interrupt key, which will undo the clearing operation.</li> <li>• It is not possible to clear the count of the counters for the fusing unit, transfer belt unit, Imaging Unit and TCR new article detection, which are provided with a new unit detection function.</li> </ul> <p>&lt;1&gt;</p> <ul style="list-style-type: none"> <li>• Fusing Unit : Number of times a sheet of paper is fed through</li> <li>• Image Transfer Belt Unit : Number of times a sheet of paper is fed through</li> <li>• 1st. : Number of sheets of paper fed from tray 1</li> <li>• 2nd. : Number of sheets of paper fed from tray 2</li> <li>• 3rd. : Number of sheets of paper fed from tray 3</li> <li>• 4th. : Number of sheets of paper fed from tray 4</li> <li>• Manual Tray : Number of sheets of paper fed from the bypass</li> </ul> <p>&lt;2&gt;</p> <ul style="list-style-type: none"> <li>• Imaging Unit (C) : Period of time over which the cyan imaging unit has been used.</li> <li>• Imaging Unit (M) : Period of time over which the magenta imaging unit has been used.</li> <li>• Imaging Unit (Y) : Period of time over which the yellow imaging unit has been used.</li> <li>• Imaging Unit (K) : Period of time over which the black imaging unit has been used.</li> <li>• LCT Parts : Number of sheets of paper fed from the LCT</li> <li>• ADF Feed : Number of sheets of paper fed through the take-up section of the ADF</li> <li>• ADF Reverse : Number of sheets of paper fed through the turnover unit of the ADF</li> <li>• Sorter/Finisher : Number of sheets of paper fed out of the sorter/finisher</li> </ul>

Setting/ Procedure	<3> <ul style="list-style-type: none"> <li>• TCR new article detection (C) : Period of time over which the cyan toner cartridge has been used.</li> <li>• TCR new article detection (M) : Period of time over which the magenta toner cartridge has been used.</li> <li>• TCR new article detection (Y) : Period of time over which the yellow toner cartridge has been used.</li> <li>• TCR new article detection (K) : Period of time over which the black toner cartridge has been used.</li> </ul>
-----------------------	--

### 10.10.3 Jam

Functions	<ul style="list-style-type: none"> <li>• To check the number of misfeeds that have occurred at different locations in the machine.</li> <li>• To clear the count of each counter.</li> </ul>
Use	<ul style="list-style-type: none"> <li>• To check the number of paper misfeeds that have occurred.</li> </ul>
Setting/ Procedure	<ul style="list-style-type: none"> <li>• To clear the count of a counter, select the specific part and press the Clear key.</li> <li>• If a counter is cleared mistakenly, press the Interrupt key, which will undo the clearing operation.</li> </ul>

### 10.10.4 Service Call Counter

Functions	<ul style="list-style-type: none"> <li>• To check the number of malfunctions that have occurred at different locations in the machine.</li> <li>• To clear the count of each counter.</li> </ul>
Use	<ul style="list-style-type: none"> <li>• To check the number of malfunctions that have occurred.</li> </ul>
Setting/ Procedure	<ul style="list-style-type: none"> <li>• To clear the count of a counter, select the specific part and press the Clear key.</li> <li>• If a counter is cleared mistakenly, press the Interrupt key, which will undo the clearing operation.</li> </ul>

### 10.10.5 Warning

Functions	<ul style="list-style-type: none"> <li>• To check the number of warning conditions detected according to the warning type</li> <li>• To clear the count of each counter.</li> </ul>
Use	<ul style="list-style-type: none"> <li>• To check the number of warning conditions that have been detected.</li> </ul>
Setting/ Procedure	<ul style="list-style-type: none"> <li>• To clear the count of a counter, select the specific part and press the Clear key.</li> <li>• If a counter is cleared mistakenly, press the Interrupt key, which will undo the clearing operation.</li> <li>• When a warning condition occurs, an oil mark appears at the lower left corner of the basic screen.</li> <li>• Touching the oil mark will display the warning code screen.</li> </ul>

**10.10.6 Maintenance**

Functions	<ul style="list-style-type: none"> <li>To set a count value for maintenance of any given part.</li> </ul>
Use	<ul style="list-style-type: none"> <li>When any given part is replaced.</li> </ul>
Setting/ Procedure	<p>Maint.-Set</p> <ul style="list-style-type: none"> <li>Enter the maintenance counter value from the 10-key pad.</li> <li>The default setting is "0."</li> </ul> <p style="text-align: center;">0 to 999999</p> <p>Maint.-Count</p> <ul style="list-style-type: none"> <li>Counts up when a sheet of paper is fed through the machine.</li> <li>A warning message appears if the count reaches a preset value.</li> <li>Pressing the Clear key will clear the count.</li> <li>If the count is cleared mistakenly, press the Interrupt key, which will undo the clearing operation.</li> </ul>

**10.10.7 Service Total****A. Total**

Functions	<ul style="list-style-type: none"> <li>To display the count value for the service total counter.</li> </ul>
Use	<ul style="list-style-type: none"> <li>Use to check the total No. of printed pages including the ones printed by the Service Mode.</li> </ul>
Setting/ Procedure	<p>Service Total : No. of pages printed by user mode and Service Mode.</p> <p>Service Total (Duplex) : No. of pages printed by user mode and Service Mode in duplex.</p>

**B. Paper Size**

Functions	<ul style="list-style-type: none"> <li>To display the count value for service total counter of each paper size.</li> </ul>
Use	<ul style="list-style-type: none"> <li>To check the total number of printed pages including the one at Service Mode according to each paper size.</li> </ul>

**10.10.8 Counter of Each Mode**

Functions	<ul style="list-style-type: none"> <li>To display the printed pages in the following specified modes; copy, printer, scanner, and fax. It also displays the count value of using the specified mode.</li> </ul>
Use	<ul style="list-style-type: none"> <li>Use to check the printed pages in the following specified modes; copy, printer, scanner, and fax, as well as No. of times each mode was used, in order to know the using condition.</li> </ul>

**10.10.9 Service Call History (Data)**

Functions	<ul style="list-style-type: none"> <li>To display the trouble history in chronological order.</li> </ul>
Use	<ul style="list-style-type: none"> <li>Use to check the trouble history in chronological order.</li> </ul>

**10.10.10 ADF Paper Pages**

Functions	<ul style="list-style-type: none"> <li>To display the No. of pages fed to the automatic document feeder.</li> </ul>
Use	<ul style="list-style-type: none"> <li>Use to check the No. of pages fed to the automatic document feeder.</li> </ul>

**10.10.11 Paper Jam History**

Functions	<ul style="list-style-type: none"> <li>To display the jam history in chronological order.</li> </ul>
Use	<ul style="list-style-type: none"> <li>Use to check the jam history in chronological order.</li> </ul> <p><b>NOTE</b></p> <ul style="list-style-type: none"> <li><b>[Code] displayed on the screen of JAM history indicates JAM code. For details of JAM code, see “Trouble shooting.”</b></li> </ul> <p>See P.463</p>

**10.10.12 Fax Connection Error**

Functions	<ul style="list-style-type: none"> <li>To display the No. of fax transmission errors occurred.</li> </ul>
Use	<ul style="list-style-type: none"> <li>Use to check the No. of fax transmission errors occurred.</li> </ul>

**10.10.13 Split Line Counter**

Functions	<ul style="list-style-type: none"> <li>To display the average number of detected stain on the ADF original glass at the pre-detection.</li> </ul> <p>Pre-detect Large Size : Large-sized detected stain divided by the number of times pre-detection is practiced (average number of detected lines) will be displayed.</p> <p>Pre-detect Small Size : Small-sized detected stain divided by the number of times pre-detection is practiced (average number of detected lines) will be displayed.</p> <p>Detect Split line in acting : Number of detected stain on the original glass during the original feed divided by the number of scanning by ADF (average number of detected lines) will be displayed.</p>
Use	<ul style="list-style-type: none"> <li>Used for checking the number of detected stain on the ADF original glass.</li> </ul>
Setting/ Procedure	<ul style="list-style-type: none"> <li>To clear each counter value, select the items to be cleared, and press the Clear key. (When selecting [Pre-detect Large Size] or [Pre-detect Small Size] is selected, both values will be cleared.)</li> <li>If the count is cleared mistakenly, press the Interrupt key, which will undo the clearing operation.</li> </ul>

## 10.11 List Output

### 10.11.1 Machine Management List

Functions	<ul style="list-style-type: none"> <li>To produce an output of a list of setting values, adjustment values, total counter values, and others.</li> </ul>
Use	<ul style="list-style-type: none"> <li>At the end of setup or when a malfunction occurs.</li> </ul>
Setting/ Procedure	<ul style="list-style-type: none"> <li>Load the A4S or 8 1/2 x 11 plain paper to a paper source.</li> <li>Press the Start key, which will let the machine produce the list.</li> <li>The time-of-day and date will also be printed.</li> </ul>

### 10.11.2 Adjustment List

Functions	<ul style="list-style-type: none"> <li>To output the adjustment list for machine adjustment, process adjustment, etc. in Service Mode.</li> </ul>
Use	<ul style="list-style-type: none"> <li>At the end of setup or when a malfunction occurs.</li> </ul>
Setting/ Procedure	<ul style="list-style-type: none"> <li>Load the A4S or 8 1/2 x 11 plain paper to a paper source.</li> <li>Press the Start key, which will let the machine produce the list.</li> <li>The time-of-day and date will also be printed.</li> </ul>

### 10.11.3 Parameter List

- For details, see FK-502 Service Manual.

### 10.11.4 Service Parameter

- For details, see FK-502 Service Manual.

### 10.11.5 Protocol Trace

- For details, see FK-502 Service Manual.

### 10.11.6 Fax Setting List

- For details, see FK-502 Service Manual.

### 10.11.7 Fax Analysis List

- For details, see FK-502 Service Manual.

## 10.12 State Confirmation

### 10.12.1 Sensor Check

Functions	<ul style="list-style-type: none"> <li>To display the states of the input ports of sensors and switches when the machine remains stationary.</li> </ul>
Use	<ul style="list-style-type: none"> <li>Used for troubleshooting when a malfunction or a misfeed occurs.</li> </ul>
Setting/ Procedure	<ul style="list-style-type: none"> <li>The operation of each of the switches and sensors can be checked on a real-time basis.</li> <li>It can be checked as long as the 5-V power line remains intact even when a door is open.</li> </ul>

#### A. Electrical components check procedure through input data check

- When a paper misfeed occurs in the paper feed section of the machine, the tray 2 paper feed sensor is considered to be responsible for it.
  - Remove the sheet of paper misfed.
  - From the sensor check list that follows, check the panel display of the tray 2 paper feed sensor. For the tray 2 paper feed sensor, you check the data of "Paper feed" of "Tray 2."
  - Call the Service Mode to the screen.
  - Select [State Confirmation] → [Sensor Check] and then select the screen that contains "Paper feed" under "Tray 2." For "Paper feed" under "Tray 2," select "1" on the left-hand side of the screen.
  - Check that the data for "Paper feed" under "Tray 2" is "0" (sensor blocked).
  - Move the actuator to unblock the tray 2 paper feed sensor.
  - Check that the data for "Paper feed" under "Tray 2" changes from "0" to "1" on the screen.
  - If the input data is "0," change the sensor.

10.12.2 Sensor check screens

- These are only typical screens which may be different from what are shown on each individual machine.

A. Sensor monitor

(1) Sensor monitor 1, 2

Sensor Check

END

---

1  
/ 7

Sensor monitor1

Paper feed tray1	Paper feed	0 Paper empty	0 Paper passage transportation
Device detection	0 Upper Limit	0 Near Empty	0 Sensor in front of P.m. Roller 0
Paper empty	0 Paper feed tray3	Vertical transport	0 Paper exit 0
Near Empty	0 Device detection	0 Paper feed	0 Fusing Loop Detect 0
Chain Feed	0 Paper empty	0 Upper Limit	0 PC Drive Detect
Upper Limit	0 Near Empty	0 Manual	Color PC Drive Main sensor 0
Paper feed tray2	Vertical transport	0 Multi FD size 1 0	Color PC Drive Sub sensor 0
Device detection	0 Paper feed	0 Multi FD size 2 0	Black PC Drive Main sensor 0
Paper empty	0 Upper Limit	0 Multi FD size 3 0	Black PC Drive Sub sensor 0
Near Empty	0 Paper feed tray4	Lift-Up Position Sensor	0 Color Dev. Unit engaged position 0
Vertical transport	0 Device detection	0 Paper empty	0

Sensor Check

END

---

2  
/ 7

Sensor monitor2

LCT	Manual Button Down	0 Secondary transfer	0
Lift-Up Upper	0 Division Board Position	0 Pressure welding alienation	0
Lift-Up Lower	0 Cassette Open	0 Transfer belt	0
Shift Tray Home	0 Shift Motor Pulse	0 Retraction	0
Shift Tray Stop	0 Elevator Motor Pulse	0 Waste Toner	0
Paper feed	0 Duplex	Waste Toner full	0
Vertical Transport	0 Paper passage 1	0 Fusing	0
paper empty	0 Paper passage 2	0 Roller Retraction	0
Main Tray Empty	0 Horizontal Trans. Unit		
Shift Tray Empty	0 Horizontal Transport		
Lower Over Run	0 Paper Detect Reverse Sensor		

A02EF3E521DB

bizhub C353/C253/C203

Adjustment / Setting

410

(2) Sensor monitor 3, 4



Sensor Check



Sensor monitor3 /Finisher 1	
3	paper passage 1 0 Elevate increase tray 0 Punch position detection2 0
7	paper passage 2 0 Elevate position detection 0 Hole-Punch Scrap Box Full 0
	Adjustment 1 home 0 Shutter home 0 Turn around remain detect. 0
	Adjustment 2 home 0 Exhaust Paddle home 0 Stapler save position 0
	Elevate up/down limit detection 0 Exhaust R home 0 Fan motor lock detection 0
	Shutter detection 0 Processing tray Paper detection 0 Output OP main body set 0
	Front cover opening detect. 0 Staple CD home sensor 0
	Punch pulse 0 Self priming 0
	Saddle Dehi guide home 0 Needling empty 0
	Elevate lower limit detection 0 Staple home 0
	Elevate surface detect. 0 Punch position detection1 0

Sensor Check



Sensor monitor4 /Finisher 2	
4	Saddle exhaust 0 Self priming 0 Bin 2
7	Folding papers R home 0 Saddle opening detection 0 Empty detection 0
	Middle guide opening detect. 0 Saddle empty 0 Full detection 0
	Saddle down guide home 0 Saddle exhaust R home 0 Bin 3
	Saddle stapler1 Bin Empty detection 0
	Home 0 Paper passage 1 0 Full detection 0
	Needling empty 0 Paper passage 2 0 Bin 4
	Self priming 0 Jam processing door opening 0 Empty detection 0
	Saddle stapler2 Bin 1 Full detection 0
	Home 0 Empty detection 0
	Needling empty 0 Full detection 0

A02EF3E522DB





(3) Sensor monitor 5, 6

bizhub C353/C253/C203

Adjustment / Setting

Sensor Check

END

---

5  
/  
7

Sensor monitors /Finisher 3	
Exit(Non-sort1)	0
Exit(Non-sort2)	0
Full(Non-sort1)	0
Full(Non-sort2)	0
Front cover	0
Route change home	0
Retraction Home	0
Home(Shift)	0

Sensor Check

END

---

6  
/  
7

Sensor monitors /Finisher 4					
Entrance	0	Crease Clock	0	Stapler Safety	0
Hole-Punch Scrap	0	Paper	0	Self Prime	0
Paddle Home	0	Paper Surface	0	Front Door	0
Punch Timing	0	Lift Raised Position	0	Punch Motor Clock	0
Bundle Roller Home	0	Lift Lowered Position	0	Upper Cover	0
Punch Clock	0	Front Door SW	0	Punch(Home)	0
Front Align	0	Remain in Reverse section	0	Punch Depth(Home)	0
Back Align	0	Joint SW	0	Horizontal Transport door	0
Alignment Tray	0	Lift Middle	0		
Home (Exit Belt)	0	Slide Home	0	Punch Depth1	0
Crease Position	0	Stapler HP	0	Punch Depth2	0
Crease Tray	0	Staple	0	Punch Depth3	0
Crease Home	0	Stapler Detect	0	Punch Depth4	0
Fold Roller HP	0				

A02EF3E523DB

412

(4) Sensor monitor 7



Sensor Check

END

---

Sensor monitor 7

7	Scanner	Original Size	0
		Detection 1	0
7	Home Sensor	Original Size	0
		Detection 2	0
	Org. Detecting Sensor	Original Size	0
		Detection 3	0
	Original Cover	Original Size	0
		Detection 4	0
	20 Degree	Original Size	0
		Detection 5	0
		Original Size	0
		Detection 6	0
		Original Size	0
		Detection 7	0
		Original Size	0
		Detection 8	0

A02EF3E527DA

bizhub C353/C253/C203

Adjustment / Setting

## 10.12.3 Sensor check list

## A. Sensor monitor

## (1) Sensor monitor 1

Symbol	Panel display	Part/signal name	Operation characteristics/panel display		
			1	0	
PS2	Paper feed tray 1	Device detection	Paper feed tray 1 device detection sensor	In position	Out of position
PS7		Paper empty	Paper feed tray 1 paper empty sensor	Paper not present	Paper present
PS9		Near Empty	Paper feed tray 1 near empty sensor	Near empty	Unblocked
PS1		Chain feed	Paper feed tray 1 chain feed sensor	Paper present	Paper not present
PS8		Upper Limit	Paper feed tray 1 upper limit sensor	At raised position	Not at raised position
PS10	Paper feed tray 2	Device detection	Paper feed tray 2 device detection sensor	In position	Out of position
PS13		Paper empty	Paper feed tray 2 paper empty sensor	Paper not present	Paper present
PS9		Near Empty	Paper feed tray 2 near empty sensor	Near empty	Unblocked
PS16		Vertical transport	Paper feed tray 2 vertical transport sensor	Paper present	Paper not present
PS14		Paper feed	Paper feed tray 2 paper feed sensor	Paper present	Paper not present
PS15		Upper Limit	Paper feed tray 2 upper limit sensor	At raised position	Not at raised position
PS112	Paper feed tray 3	Device detection	<a href="#">See P.19 of the PC-104/204 service manual.</a>		
PS115		Paper empty			
PS113		Near Empty			
PS117		Vertical transport			
PS116		Paper feed			
PS114		Upper Limit			
PS121	Paper feed tray 4	Device detection	<a href="#">See P.19 of the PC-104/204 service manual.</a>		
PS124		Paper empty			
PS122		Near Empty			
PS126		Vertical transport			
PS125		Paper feed			
PS123		Upper Limit			

Symbol	Panel display	Part/signal name	Operation characteristics/panel display		
			1	0	
PS18	Manual	Multi FD size 1	Manual multi FD size sensor/1	ON	OFF
PS19		Multi FD size 2	Manual multi FD size sensor/2	ON	OFF
PS20		Multi FD size 3	Manual multi FD size sensor/3	ON	OFF
PS17		Lift-Up Position Sensor	Manual lift-up position sensor	Paper not present	Paper present
PS21		Paper empty	Manual paper empty sensor	At raised position	Not at raised position
PS23	Paper passage transportation	Sensor in front of tim. roller.	Sensor in front of tim. roller	Paper present	Paper not present
PS25		Paper exit	Paper exit sensor	Paper present	Paper not present
PS24		Fusing Loop Detect	Fusing loop detect sensor	Loop present	Loop not present
PS27	Photo conductor	Color PC Drive Main Sensor	Color PC drive main sensor	Blocked	Unblocked
PS28		Color PC Drive Sub Sensor	Color PC drive sub sensor	Blocked	Unblocked
PS29		Black PC Drive Main Sensor	Black PC drive main sensor	Blocked	Unblocked
PS30		Black PC Drive Sub Sensor	Black PC drive sub sensor	Blocked	Unblocked
PS26		Color Dev. Unit engaged position	Color dev. unit engaged position sensor	engaged	not engaged

bizhub\_C353/C253/C203

Adjustment / Setting

**(2) Sensor monitor 2**

Symbol	Panel display		Part/signal name	Operation characteristics/panel display	
				1	0
PS4	LCT	Lift-Up Upper	See P.23 of the PC-405 service manual.		
PS13		Lift-Up Lower			
PS12		Shift Tray Home			
PS11		Shift Tray Stop			
PS1		Paper feed			
PS2		Vertical Transport			
PS3		Paper empty			
MTPEB		Main Tray Empty			
PS9		Shift Tray Empty			
PS7		Lower Over Run			
MDCB		Manual Button Down			
PS14		Division Board Position			
PS6		Cassette Open			
PS8		Shift Motor Pulse			
PS10		Elevator Motor Pulse			
PS33	Duplex	Paper passage1	Duplex paper passage sensor/1	Paper present	Paper not present
PS34		Paper passage2	Duplex paper passage sensor/2	Paper present	Paper not present
PS25	Horizontal Trans. Unit	Horizontal Transport	Paper sensor	Paper present	Paper not present
—		Paper Detect Reverse Sensor	—	—	—
PS36	secondary transfer	Pressure welding alienation	2nd image transfer welding alienation sensor	Not Retracted	Retracted
PS31	Transfer belt	Retraction	Transfer belt retraction sensor	Not Retracted	Retracted
PS32	Waste toner	Waste toner full	Waste toner full sensor	Blocked	Unblocked
PS38	Fusing	Roller retraction	Fusing roller retraction sensor	Not Retracted	Retracted



**(3) Sensor monitor 3**

Symbol	Panel display	Part/signal name	Operation characteristics/ panel display	
			1	0
PS1	Carrying Paper Passage	See P.61 of the FS-519/PK-515/OT-602 service manual.		
PS2	Middle Paper Passage			
PS7	Home1 (CD-Align)			
PS8	Home2 (CD-Align)			
SW3	Elevate Tray Raised/ Lowered			
SW2	Shutter			
SW1	Front Cover			
PS502	Punch Pulse			
PS23	Home (Saddle In and Out)			
PS13	Elevate Tray Lowered			
PS12	Surface (Elev.)			
-	Elevate Tray Proliferation			
PS11	Elevate Position			
PS14	Home (Shutter)			
PS6	Home (Exit Paddle)			
PS5	Home (Exit R)			
PS3	Empty (Finisher)			
PS9	Home (Staple CD)			
-	Self Printing			
-	Staple Empty			
-	Home (Stapler)			
PS500	Punch Position1			
PS501	Punch Position2			
PS503	Punch Dust Full			
PS4	Remain in Reverse Section			
PS10	Stapler Save Position			
M9	Fan Motor Lock			
SW4	Exit OP Machine Set			

Sensors monitor3

bizhub\_C353/C253/C203

Adjustment / Setting

**(4) Sensor monitor 4**

Symbol	Panel display		Part/Signal name	Operation characteristics/panel display	
				1	0
PS20	Sensors monitor 4	Saddle exit	<a href="#">See P.27 of the SD-505 service manual.</a>		
PS22		Folding R home			
SW5		Middle guide			
PS24		Saddle guide			
—		Saddle stapler 1			
—		Home			
—		Staple empty			
—		Self priming			
—		Saddle stapler 2			
—		Home			
—		Staple empty			
—		Self priming			
SW4		Saddle			
PS21		Saddle empty			
PS18		Home (Saddle exit)			
PS10	Bin	Paper Passage 1	<a href="#">See P.9 of the MT-502 service manual.</a>		
PS9		Paper Passage 2			
PS11		Door (Jam)			
PS1	Bin1	Empty			
PS5		Full			
PS2	Bin2	Empty			
PS6		Full			
PS3	Bin3	Empty			
PS7		Full			
PS4	Bin4	Empty			
PS8		Full			

**(5) Sensor monitor 5**

Symbol	Panel display		Part/Signal name	Operation characteristics/panel display	
				1	0
PS1	Sensors monitor 5	Exit (Non-sort 1)	See P.16 of the JS-505 service manual.		
PS2		Exit (Non-sort 2)			
T1FDTB/ LED		Full (Non-sort 1)			
T2FDTB/ LED		Full (Non-sort 2)			
PS3		Front cover			
PS4		Route change home			
PS5		Retraction home			
PS6		Home (Shift)			

bizhub\_C353/C253/C203

Adjustment / Setting



bizhub C353/C253/C203

Adjustment / Setting

**(6) Sensor monitor 6**



Symbol	Panel display	Part/Signal name	Operation characteristics/panel display	
			1	0
PS1	Entrance	See P.35 of the FS-609/PK-501 service manual.		
PS2	Paddle Home			
PS3	Bundle Roller Home			
PS4	Front Align			
PS5	Back Align			
PS6	Alignment Tray			
PS7	Home (Exit Belt)			
PS10	Crease Position			
PS13	Crease Tray			
PS11	Crease Home			
PS12	Fold Roller HP			
PS14	Crease Clock			
PS8	Paper			
PS9	Paper Surface			
PS15	Lift Raised Position			
PS16	Lift Lowered Position			
PS17	Lift Clock			
—	Lift Middle			
PS18	Slide Home			
PS19	Stapler HP			
PS20	Staple			
—	Stapler Detect			
SW3 SW4	Stapler Safety			
PS21	Self Prime			
PS22	Front Door			
PS23	Upper Cover			
SW1	Front Door SW			
—	Remain in Reverse Section			
SW2	Joint SW			
—	Punch Depth1			
—	Punch Depth2			
—	Punch Depth3			
—	Punch Depth4			
—	Hole-Punch Scrap			



Symbol	Panel display		Part/Signal name	Operation characteristics/panel display	
				1	0
—	Sensors monitor 6	Punch Timing	See P.35 of the FS-609/PK-501 service manual.		
PS3		Punch Motor Clock			
PS1		Punch (Home)			
PS2		Punch Depth (Home)			
PS26		Horizontal Transport Door			

**(7) Sensor monitor 7**



Symbol	Panel display		Part/signal name	Operation characteristics/panel display	
				1	0
PS201	Scanner	Home Sensor	Scanner home sensor	At home	Out of home
S201		Original Cover	Original cover sensor	Lowered	Raised
PS202	Org. Detecting Sensor	20 Degree	20 degree sensor	Less than 20 degree	20 degree or more
PS204		Original Size Detection 1	Original size detection 1 sensor	Original loaded, not mounted	Original not loaded
PS205		Original Size Detection 2	Original size detection 2 sensor	Original loaded, not mounted	Original not loaded
—		Original Size Detection 3	Not used	—	—
—		Original Size Detection 4	Not used	—	—
—		Original Size Detection 5	Not used	—	—
—		Original Size Detection 6	Not used	—	—
—		Original Size Detection 7	Not used	—	—
—	Original Size Detection 8	Not used	—	—	



**10.12.4 Table Number**

Functions	<ul style="list-style-type: none"> <li>When IDC is detected, for plain paper, Thick 1, Thick, and Black, the machine independently displays each Vg/Vdc output value that is calculated based on the density (toner amount stuck on the belt) of the test pattern created on the transfer belt.</li> <li>Reference values: C, M, Y K Vdc: around 400 V, Vg: around 500 V</li> </ul>
Use	Used for troubleshooting of image problems.
Setting/ Procedure	<ul style="list-style-type: none"> <li>If the value is high, correct so that the image density becomes low.</li> <li>If the value is low, correct so that the image density becomes high.</li> </ul>

**10.12.5 Level History1**

Functions	<ul style="list-style-type: none"> <li>To display TCR (T/C ratio), IDC/registration sensor output values, and fusing temperature.</li> </ul>
Use	Used for troubleshooting of image problems.
Setting/ Procedure	<ul style="list-style-type: none"> <li>TCR-C/-M/-Y/-K : Shows the T/C output reading taken last.</li> <li>IDC1/IDC2 : Shows the latest IDC data.</li> <li>Temp-Heat : Displays the latest temperature of the heating roller.</li> <li>Temp-Press : Displays the latest temperature of the pressure roller.</li> </ul> <p>“Reading taken last” means</p> <ul style="list-style-type: none"> <li>Density of toner of the latest image.</li> <li>When a test print is produced by pressing the Start key while level history 1 is being displayed.</li> </ul>

**10.12.6 Level History 2**

Functions	<ul style="list-style-type: none"> <li>IDC Sensor (Transfer belt bare surface level) as adjusted through the image stabilization sequence and ATVC value.</li> </ul>
Use	Used for troubleshooting of image problems.
Setting/ Procedure	<ul style="list-style-type: none"> <li>IDC Sensor: Shows the intensity adjustment value (0 to 255) of the IDC sensor.</li> <li>ATVC (C, M, Y, K): Shows the first image transfer ATVC adjustment value (5 to 40 <math>\mu</math>A).</li> <li>ATVC (2nd) : Shows the second image transfer ATVC adjustment value (300 to 480 V).</li> </ul>

**10.12.7 Temp. & Humidity**

Functions	<ul style="list-style-type: none"> <li>To display the temperature and humidity of a specific location (AIDC sensor portion) inside the machine and fusing temperature.</li> </ul>
Use	Used as reference information when a malfunction occurs.
Setting/ Procedure	<ul style="list-style-type: none"> <li>Temp-Inside : 0 to 100 °C in 1 °C increments</li> <li>Temp-Heater : 0 to 260 °C in 1 °C increments</li> <li>Temp-press. : 0 to 260 °C in 1 °C increments</li> <li>Humidity : 0 to 100 % in 1 % increments</li> <li>Absolute Humidity : 0 to 100 in 1 increments</li> </ul>

**10.12.8 CCD Check**

Functions	<ul style="list-style-type: none"> <li>To display the D/A value of CCD clamp/gain for R, G, and B.</li> </ul>
Use	<ul style="list-style-type: none"> <li>Used for troubleshooting for the CCD sensor.</li> </ul>
Setting/ Procedure	<ul style="list-style-type: none"> <li>Use the following guidelines on the correct range of values. CLAMP: The difference between the max. and min. output values should be within <math>\pm 100</math>. GAIN : The difference from the CLAMP values (R, B) should be within (90 for R and B. The difference from the CLAMP value (G) should be within <math>\pm 50</math> for G. The difference between each pair of RO and RE, GO and GE, and BO and BE should be within 30.</li> </ul>

**10.12.9 Memory/HDD Adj.****A. Memory Check**

Functions	<ul style="list-style-type: none"> <li>To check correspondence of data written to and that read from memory through write/read check.</li> </ul> <p>Rough Check</p> <ul style="list-style-type: none"> <li>A check is made to see if the image data reading and writing are correctly made in a very limited area.</li> <li>The progress of the check sequence is displayed in percentage.</li> </ul> <p>Detail Check</p> <ul style="list-style-type: none"> <li>A check is made to see if the image data reading and writing are correctly made at the addresses and buses in all areas.</li> <li>The progress of the check sequence is displayed in percentage.</li> </ul>
Use	<ul style="list-style-type: none"> <li>If the copy image is faulty.</li> </ul>
Adjustment Procedure	<ol style="list-style-type: none"> <li>Call the Service Mode to the screen.</li> <li>Touch these keys in this order: [State Confirmation] → [Memory / HDD Adj.] → [Memory Check].</li> <li>Select the desired type of check, either [Rough Check] or [Detail Check].</li> <li>Press the Start key to start the check procedure.</li> <li>When the check procedure is completed, the results are shown on the screen. If the check results are NG, check the memory for connection or replace the memory with a new one.</li> </ol> <p>* Press the Stop key to interrupt the check sequence.</p>

**B. Compress / Decompression Check**

Functions	<ul style="list-style-type: none"> <li>To check whether compression and decompression are carried out properly.</li> </ul>
Use	<ul style="list-style-type: none"> <li>If the copy image is faulty.</li> </ul>
Adjustment Procedure	<ol style="list-style-type: none"> <li>Call the Service Mode to the screen.</li> <li>Touch these keys in this order: [State Confirmation] → [Memory / HDD Adj.] → [Compress / Decompression Check].</li> <li>Pressing the Start key will automatically start to complete a compression/decompression check sequence.</li> <li>The check result will be displayed.</li> </ol>

**C. JPEG check**

- This function is available only when the optional scan accelerator kit (SA-501) is mounted.

Functions	<ul style="list-style-type: none"> <li>• This function enables you to check whether image data are compressed properly through the scan accelerator kit (SA-501).</li> </ul>
Use	<ul style="list-style-type: none"> <li>• When a copy image problem occurs, you can refer to JPEG check.</li> </ul>
Adjustment Procedure	<ol style="list-style-type: none"> <li>1. Call the Service Mode to the screen.</li> <li>2. Touch these keys in this order: [State Confirmation] → [Memory / HDD Adj.] → [JPEG check].</li> <li>3. Pressing the Start key will automatically start to complete a JPEG check sequence.</li> <li>4. The check result will be displayed.</li> </ol>

**D. Memory Bus Check**

Functions	<ul style="list-style-type: none"> <li>• To check to see if image data is correctly transferred from scanner to memory, and from memory to printer.</li> </ul>
Use	<ul style="list-style-type: none"> <li>• If the copy image is faulty.</li> </ul>
Adjustment Procedure	<ol style="list-style-type: none"> <li>1. Call the Service Mode to the screen.</li> <li>2. Touch these keys in this order: [State Confirmation] → [Memory / HDD Adj.] → [Memory Bus Check].</li> <li>3. Select either [Scanner → Memory], [Memory → PRT], or both.</li> <li>4. Pressing the Start key will start the memory bus check and be terminated automatically.</li> <li>5. The check result will be displayed, [OK] or [NG].</li> </ol>

**E. Work Memory In/Out Check**

Functions	<ul style="list-style-type: none"> <li>• To check to see if input and output of image data of work memory are correctly performed.</li> </ul>
Use	<ul style="list-style-type: none"> <li>• If the print image is faulty.</li> </ul>
Adjustment Procedure	<ol style="list-style-type: none"> <li>1. Call the Service Mode to the screen.</li> <li>2. Touch these keys in this order: [State Confirmation] → [Memory / HDD Adj.] → [Work Memory In/Out Check].</li> <li>3. Select either [Input Check], [Output Check], or both.</li> <li>4. Pressing the Start key will start the work memory input/output operation check sequence and be terminated automatically.</li> <li>5. The check result will be displayed, [OK] or [NG].</li> </ol>

**F. HDD Version Upgrade (LK)**

- This is displayed only when the function enhanced version 2 or later firmware is installed.

Functions	<ul style="list-style-type: none"> <li>• To maintain the compatibility of management information data and documents stored in HDD after the firmware upgrade.</li> </ul>
Use	<ul style="list-style-type: none"> <li>• This must be performed after upgrading the firmware to the function enhanced version 2.</li> </ul>
Adjustment Procedure	<ol style="list-style-type: none"> <li>1. Call the Service Mode to the screen.</li> <li>2. Touch [State Confirmation] → [Memory/HDD Adj.] → [HDD Version Upgrade (LK)].</li> <li>3. Touch Start key to initiate upgrading the current HDD version.</li> <li>4. When the upgrade is completed, the result is displayed on the screen.</li> </ol> <p><b>NOTE</b></p> <ul style="list-style-type: none"> <li>• <b>Make sure to turn OFF the main power switch when firmware upgrade is completed, and turn it ON again more than 10 seconds after.</b></li> </ul>

### G. HDD Version Up

Functions	<ul style="list-style-type: none"> <li>To upgrade administration data (Document management information, address information, etc.) other than image data in HDD.</li> </ul>
Use	
Adjustment Procedure	<ol style="list-style-type: none"> <li>Open the Service Mode.</li> <li>Set the following setting. [State Confirmation] → [Memory/HDD Adj.] → [HDD Version Up]</li> <li>Touch the Start key to start upgrading the version.</li> <li>When upgrading the version is complete, the outcome will be displayed on the screen.</li> </ol> <p><b>NOTE</b></p> <ul style="list-style-type: none"> <li><b>Make sure to turn main power switch OFF when upgrading is complete, and wait for ten seconds to turn back ON.</b></li> </ul>

### H. HDD R/W Check

Functions	<ul style="list-style-type: none"> <li>To check to see if the hard disk is connected properly, and if read/write operation of the hard disk is correctly performed.</li> </ul>
Use	<ul style="list-style-type: none"> <li>When the hard disk is mounted.</li> </ul>
Adjustment Procedure	<ol style="list-style-type: none"> <li>Call the Service Mode to the screen.</li> <li>Touch these keys in this order: [State Confirmation] → [Memory / HDD Adj.] → [HDD R/W Check].</li> <li>Pressing the Start key will start the hard disk R/W check sequence and be terminated automatically.</li> <li>The check result will be displayed, [OK] or [NG].</li> </ol>

### I. HDD Format

Functions	<ul style="list-style-type: none"> <li>To format the hard disk.</li> <li>The function proceeds in the order of physical format to logical format.</li> <li>If the hard disk is yet to be formatted, the malfunction code "C-D010" will appear. Ignore this code and continue with the formatting procedure.</li> </ul>
Use	<ul style="list-style-type: none"> <li>When the hard disk is mounted.</li> <li>When the hard disk is to be initialized. (Physical format to logical format)</li> </ul>
Adjustment Procedure	<ol style="list-style-type: none"> <li>Call the Service Mode to the screen.</li> <li>Touch these keys in this order: [State Confirmation] → [Memory / HDD Adj.] → [HDD Format].</li> </ol> <p><b>(1) Physical Format</b></p> <ol style="list-style-type: none"> <li>Touch [Physical Format].</li> <li>Press the Start key to start the formatting sequence.</li> <li>The sequence will be automatically terminated as it is completed.</li> <li>Turn off the main power switch and turn it on again more than 10 seconds after.</li> </ol> <p><b>(2) Logical Format (only when initial is set up)</b></p> <ol style="list-style-type: none"> <li>Touch [Logical Format].</li> <li>Press the Start key to start the formatting sequence.</li> <li>The sequence will be automatically terminated as it is completed.</li> <li>Turn off the main power switch and turn it on again more than 10 seconds after.</li> </ol> <p>* Formatting the hard disk will erase all data contained in it.</p>

**10.12.10 Memory/HDD State**

Functions	<ul style="list-style-type: none"> <li>To display the condition and amount of the memory and hard disk.</li> <li>To display the mounting condition of the optional encryption board (security kit SC-503).</li> </ul>
Use	<ul style="list-style-type: none"> <li>Use to check the condition and amount of the memory and hard disk.</li> <li>Use to setup the optional security kit SC-503.</li> </ul>
Setting/ Procedure	<ul style="list-style-type: none"> <li>When the encryption board is mounted, the machine automatically recognizes it and displays [Set].</li> </ul>

**10.12.11 Color Regist**

Functions	<ul style="list-style-type: none"> <li>To check each of C, M, and Y for color shift amount.</li> <li>The data is updated after a color shift correction has been made or color shift adjustment has been completed.</li> </ul>
Use	<ul style="list-style-type: none"> <li>Use for check when color shift is evident.</li> <li>Use for adjustment of PH skew.</li> </ul>
Setting/ Procedure	<ul style="list-style-type: none"> <li>For each of C, M, and Y, the color shift amount (in X and Y directions) at two locations (one at the front and the other in the rear) and the difference in color shift amount between the front and rear (X and Y directions) are displayed.</li> <li>Display unit: dots</li> <li>The shift amounts is displayed with reference to K for C, M and Y, and that for K is displayed with reference to an ideal position.</li> </ul>

**10.12.12 IU Lot No.**

Functions	<ul style="list-style-type: none"> <li>To display the 10-digit lot number for each of Cyan, Magenta, Yellow, and Black IUs.</li> <li>The lot number data is stored in EEPROM of each IU.</li> </ul>
Use	<ul style="list-style-type: none"> <li>Use for checking the IU Lot No.</li> </ul>

**10.12.13 Adjustment Data List**

Functions	<ul style="list-style-type: none"> <li>To display the adjustment and setting value set in the main body.</li> </ul>
Use	<ul style="list-style-type: none"> <li>Use to check the adjustment and setting value set in the main body.</li> </ul>

### 10.13 Test Mode

- To check the image on the printer side by letting the machine produce various types of test pattern. It also tests the printing operation in running mode, as well as the fax transmission.
- The machine searches through the paper sources in the order of tray 2, tray 3, tray 4, and tray 1 for paper of the maximum size for printing.

#### 10.13.1 Procedure for test pattern output

1. Touch [Test Mode] to display the test mode menu.
2. Touch the desired test pattern key.
3. Set up the desired functions and press the Start key.

#### 10.13.2 Gradation Pattern

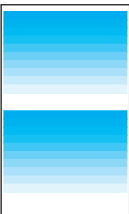
Functions	<ul style="list-style-type: none"> <li>• To produce a gradation pattern.</li> </ul>
Use	<ul style="list-style-type: none"> <li>• Used for checking gradation reproducibility.</li> </ul>
Pattern	<div style="text-align: center;">  </div> <p style="text-align: right;">                 SINGLE                  HYPER                  Gradation                  Cyan             </p> <p style="text-align: right; font-size: small;">A02EF3C510DA</p>
Setting/ Procedure	<ul style="list-style-type: none"> <li>• # of Print ("1" to 999)</li> <li>• Select "SINGLE" (single copy) or MULTI (multi copy).</li> <li>• Select FEET or "HYPER".</li> <li>• Select "Gradation" or Resolution if HYPER has been selected.</li> <li>• Select the color mode.                      "Cyan", Magenta, Yellow, Black (4PC), CMYK, 8Color, 4Color, Black (1PC)</li> <li>• Black (4PC): Uses four colors.</li> <li>• Black (1PC): Uses one color of black.</li> </ul>

bizhub\_C353/C253/C203

Adjustment / Setting

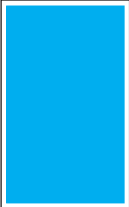

**10.13.3 Halftone Pattern**

Functions	<ul style="list-style-type: none"> <li>To produce a solid halftone pattern.</li> </ul>
Use	<ul style="list-style-type: none"> <li>Used for checking uneven density and pitch noise.</li> </ul>
Pattern	<div style="display: flex; align-items: center;">  <div style="margin-left: 20px;"> <p>SINGLE HYPER Gradation Cyan Density: 255</p> <p>A02EF3C519DA</p> </div> </div>
Setting/ Procedure	<ul style="list-style-type: none"> <li># of Print ("1" to 999)</li> <li>Select "SINGLE" (single copy) or MULTI (multi copy).</li> <li>Select FEET or "HYPER."</li> <li>Select "Gradation" or Resolution if HYPER has been selected.</li> <li>Select the color mode. "Cyan", Magenta, Yellow, Black (4PC), Red, Green, Blue, CMYK, 3 Color, 4 Color, Black (1PC), MIX</li> <li>Type the density level (0 to "255").</li> </ul>

**10.13.4 Lattice Pattern**

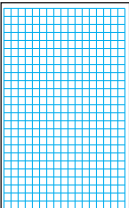
Functions	<ul style="list-style-type: none"> <li>To produce a lattice pattern.</li> </ul>
Use	<ul style="list-style-type: none"> <li>Used for checking fine line reproducibility and uneven density.</li> <li>A reverse pattern is also used to check for fine line reproducibility of white letters on a solid background.</li> </ul>
Pattern	<div style="display: flex; align-items: center;">  <div style="margin-left: 20px;"> <p>SINGLE FEET Cyan CD Width: 5 FD Width: 5 Density: 255 Normal</p> <p>A02EF3C511DA</p> </div> </div>
Setting/ Procedure	<ul style="list-style-type: none"> <li># of Print ("1" to 999)</li> <li>Select "SINGLE" (single copy) or MULTI (multi copy).</li> <li>Select "FEET" or HYPER.</li> <li>Select Gradation or Resolution. (Only select HYPER)</li> <li>Select the color mode. "Cyan", Magenta, Yellow, Black (4PC), Red, Green, Blue, CMYK, 3 Color, 4 Color, Black (1PC)</li> <li>Enter CD width and FD width (0 to 191 dots).</li> <li>Type the density level (0 to "255").</li> <li>Select "Normal" or Reverse.</li> </ul>

**10.13.5 Solid Pattern**

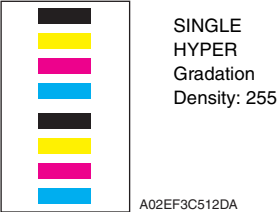
Functions	<ul style="list-style-type: none"> <li>To produce each of the C, M, Y, and K solid patterns.</li> </ul>
Use	<ul style="list-style-type: none"> <li>Used for checking reproducibility of image density.</li> </ul>
Pattern	 <p>SINGLE HYPER Gradation Density: 255</p> <p>A02EF3C512DA</p>
Setting/ Procedure	<ul style="list-style-type: none"> <li># of Print ("1" to 999)</li> <li>Select "SINGLE" (single copy) or MULTI (multi copy).</li> <li>Select FEET or "HYPER."</li> <li>Select "Gradation" or Resolution if HYPER has been selected.</li> <li>Type the density level (0 to "255").</li> </ul>

**10.13.6 Color Sample**

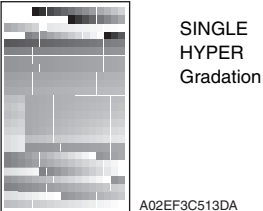
Functions	<ul style="list-style-type: none"> <li>To produce a color sample.</li> </ul>
Use	<ul style="list-style-type: none"> <li>Used for checking reproducibility of each of the different colors.</li> </ul>
Pattern	 <p>SINGLE HYPER Gradation</p> <p>A02EF3C513DA</p>
Setting/ Procedure	<ul style="list-style-type: none"> <li># of Print ("1" to 999)</li> <li>Select "SINGLE" (single copy) or MULTI (multi copy).</li> <li>Select FEET or "HYPER."</li> <li>Select "Gradation" or Resolution if HYPER has been selected.</li> <li>Produce 12-gradation-level patches of C, M, Y, K, R, G, and B, and a patch of each of the 12 reference colors in the hue circle with lightness and saturation corrected.</li> </ul>

bizhub\_C353/C253/C203

Adjustment / Setting

**10.13.7 8 Color Solid Pattern**

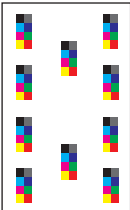
Functions	<ul style="list-style-type: none"> <li>To produce an 8-color solid pattern.</li> </ul>
Use	<ul style="list-style-type: none"> <li>Used for checking color reproducibility and uneven density of each color.</li> </ul>
Pattern	 <p>SINGLE HYPER Gradation Density: 255</p> <p>A02EF3C514DA</p>
Setting/ Procedure	<ul style="list-style-type: none"> <li># of Print ("1" to 999)</li> <li>Select "SINGLE" (single copy) or MULTI (multi copy).</li> <li>Select FEET or "HYPER."</li> <li>Select "Gradation" or Resolution if HYPER has been selected.</li> <li>Type the density level (0 to "255").</li> </ul>

**10.13.8 CMM pattern**

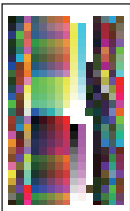
Functions	<ul style="list-style-type: none"> <li>To produce a CMM (Color Management Module) pattern.</li> </ul>
Use	<ul style="list-style-type: none"> <li>Used to check color difference depending on the places where output is made.</li> </ul>
Pattern	 <p>Error diffusion 270 degrees</p> <p>A02EF3C515DA</p>
Setting/ Procedure	<ul style="list-style-type: none"> <li># of Print is always "1".</li> <li>Select "Error diffusion", Gradation, or Resolution.</li> <li>Select an angle from among "0 degrees", 90 degrees, 180 degrees, and 270 degrees.</li> </ul>

**10.13.9 Running Mode**

Functions	<ul style="list-style-type: none"> <li>To test the printing operation in running mode.</li> </ul>
Use	<ul style="list-style-type: none"> <li>Use to check the printing operation in running mode from each paper source.</li> </ul>
Setting/ Procedure	<ol style="list-style-type: none"> <li>Call the Service Mode to the screen.</li> <li>Touch these keys in this order: [Test Mode] → [Running Mode].</li> <li>Select the paper size (Tray 1, bypass only).</li> <li>Select the paper type.</li> <li>Press the Start key to start the running mode.</li> <li>Pressing the Stop key will stop operation.</li> </ol>

### 10.13.10 Fax Test

- For details, see FK-502 Service Manual.

## 10.14 ADF

See P.28 of the DF-611 service manual.

## 10.15 FAX

- For details, see FK-502 Service Manual.

## 10.16 Finisher

### 10.16.1 CB-FN adjustment

#### A. Fold&Staple Pos. Adjustment

##### (1) Fold Position Adjustment

See P.30 of the SD-505 service manual.

##### (2) Center Staple position Adjustment

See P.32 of the SD-505 service manual.

#### B. Finisher Check

See P.62 of the FS-519/PK-515/OT-602 service manual.

#### C. Punch Regist Loop Size

See P.64 of the FS-519/PK-515/OT-602 service manual.

#### D. Punch Horizontal Position

See P.65 of the FS-519/PK-515/OT-602 service manual.

### 10.16.2 FN-X3 Adjustment

See P.37 of the FS-609/PK-501 service manual.

### 10.16.3 Punch option setting

See P.66 of the FS-519/PK-515/OT-602 service manual.

See P.40 of the FS-609/PK-501 service manual.

### 10.16.4 Job Separator

See P.17 of the JS-505 service manual.

## 10.17 Internet ISW

- By using this setting, the firmware stored in the server can be downloaded over internet for upgrading.
- For details for upgrading the firmware, refer to “Firmware upgrade” in the Maintenance section.

See P.50

### 10.17.1 Internet ISW Set

Functions	<ul style="list-style-type: none"> <li>• To set whether or not to enable each setting for Internet ISW.</li> </ul>
Use	<ul style="list-style-type: none"> <li>• To use when upgrading the firmware by Internet ISW.</li> <li>• Each setting such as Server setting will be valid by setting this to “ON”.</li> </ul> <p><b>NOTE</b></p> <ul style="list-style-type: none"> <li>• <b>When the following setting is set to “ON”, this setting will automatically be set to “OFF” and cannot be changed.</b> [Administrator Settings] → [Security Settings] → [Enhanced Security Mode]</li> </ul>
Setting/ Procedure	<ul style="list-style-type: none"> <li>• The default setting is OFF.</li> </ul> <p style="text-align: center;">ON <span style="float: right;">“OFF”</span></p>

### 10.17.2 HTTP Setting

- It will be displayed only when [Internet ISW Set] is set to “ON”.

#### A. Data Input Setting

Functions	<ul style="list-style-type: none"> <li>• To set whether or not to enable downloading using the HTTP protocol.</li> </ul>
Use	<ul style="list-style-type: none"> <li>• To use when accessing the server using the HTTP protocol.</li> <li>• Setting on the proxy server will be valid when this setting is “ON”.</li> </ul>
Setting/ Procedure	<ul style="list-style-type: none"> <li>• The default setting is OFF.</li> </ul> <p style="text-align: center;">ON <span style="float: right;">“OFF”</span></p>

#### B. Connect Proxy

Functions	<ul style="list-style-type: none"> <li>• To set whether or not to connect via proxy server when accessing the server.</li> </ul>
Use	<ul style="list-style-type: none"> <li>• To use when accessing the server via proxy server.</li> </ul>
Setting/ Procedure	<ul style="list-style-type: none"> <li>• The default setting is OFF.</li> </ul> <p style="text-align: center;">ON <span style="float: right;">“OFF”</span></p>

#### C. Proxy Server

Functions	<ul style="list-style-type: none"> <li>• To set the address and the port number for the proxy server.</li> </ul>
Use	<ul style="list-style-type: none"> <li>• To use when accessing the server via proxy server.</li> </ul>
Setting/ Procedure	<p>&lt;Server Address&gt;</p> <ul style="list-style-type: none"> <li>• Enter an address using IPv4, IPv6, or FQDN format.</li> </ul> <p>&lt;Port Number&gt;</p> <ul style="list-style-type: none"> <li>• Enter the value between 1 and 65535 using the 10-key pad. (The default setting is 80)</li> </ul>

### D. Proxy Authentication

Functions	<ul style="list-style-type: none"> <li>To set the login name or password when authentication is necessary for accessing the proxy server.</li> </ul>
Use	<ul style="list-style-type: none"> <li>To use when authentication is necessary for accessing the proxy server.</li> </ul>
Setting/ Procedure	<p>&lt;Authentication&gt;</p> <ul style="list-style-type: none"> <li>The default setting is OFF.</li> </ul> <p style="text-align: center;">ON <span style="float: right;">"OFF"</span></p> <p>&lt;Log-in Name&gt;</p> <ul style="list-style-type: none"> <li>Enter the login name (up to 32 one-byte characters) on the on-screen keyboard.</li> </ul> <p>&lt;Password&gt;</p> <ul style="list-style-type: none"> <li>Enter the password (up to 32 one-byte characters) on the on-screen keyboard.</li> </ul>

### E. Connection Time-Out

Functions	<ul style="list-style-type: none"> <li>To set the time for the timeout for accessing the server.</li> </ul>
Use	<ul style="list-style-type: none"> <li>To use when changing the time for the timeout for accessing the server.</li> </ul>
Setting/ Procedure	<ul style="list-style-type: none"> <li>The default setting is 60 sec.</li> </ul> <p style="text-align: center;">30 to 300 sec.</p>

### 10.17.3 FTP Setting

- It will be displayed only when [Internet ISW Set] is set to "ON".

#### A. Data Input Setting

Functions	<ul style="list-style-type: none"> <li>To set whether or not to enable downloading using FTP protocol.</li> </ul>
Use	<ul style="list-style-type: none"> <li>To use when accessing the server with FTP protocol.</li> <li>Setting this to "ON" will enable the proxy server setting.</li> </ul>
Setting/ Procedure	<ul style="list-style-type: none"> <li>The default setting is ON.</li> </ul> <p style="text-align: center;">"ON" <span style="float: right;">OFF</span></p>

#### B. Connect Proxy

Functions	<ul style="list-style-type: none"> <li>To set whether or not to access the server via proxy server.</li> </ul>
Use	<ul style="list-style-type: none"> <li>To use when accessing the server via proxy server.</li> </ul>
Setting/ Procedure	<ul style="list-style-type: none"> <li>The default setting is OFF.</li> </ul> <p style="text-align: center;">ON <span style="float: right;">"OFF"</span></p>

#### C. Proxy Server

Functions	<ul style="list-style-type: none"> <li>To set the address and the port No. of the proxy server.</li> </ul>
Use	<ul style="list-style-type: none"> <li>To use when accessing the server via proxy server.</li> </ul>
Setting/ Procedure	<p>&lt;Server Address&gt;</p> <ul style="list-style-type: none"> <li>Enter an address using IPv4, IPv6, or FQDN format.</li> </ul> <p>&lt;Port Number&gt;</p> <ul style="list-style-type: none"> <li>Enter the value between 1 and 65535 using the 10-key pad.</li> </ul>

### D. Connection Setting

Functions	<ul style="list-style-type: none"> <li>To set the port No. and the time for timeout when accessing the FTP server, and also to set whether or not to enable PASV mode.</li> </ul>
Use	<ul style="list-style-type: none"> <li>To use when accessing the FTP server.</li> <li>To use when connecting by the PASV (passive) mode (FTP server side will inform the connection port before connecting).</li> </ul>
Setting/ Procedure	<p>&lt;Port Number&gt;</p> <ul style="list-style-type: none"> <li>Enter the value between 1 and 65535 using the 10-key pad.</li> </ul> <p>&lt;Connection Time Out&gt;</p> <ul style="list-style-type: none"> <li>Enter the value between 1 and 60 (min.) using the 10-key pad.</li> </ul> <p>&lt;PASV Mode&gt;</p> <ul style="list-style-type: none"> <li>The default setting is OFF.</li> </ul> <p style="text-align: center;">ON <span style="float: right;">"OFF"</span></p>

## 10.17.4 Forwarding Access Setting

### A. User ID

Functions	<ul style="list-style-type: none"> <li>To register the user ID for accessing the program server where firmware is to be stored.</li> </ul>
Use	
Setting/ Procedure	<ol style="list-style-type: none"> <li>Select [User ID].</li> <li>Enter the user ID (up to 64 one-byte characters) on the on-screen keyboard.</li> </ol>

### B. Password

Functions	<ul style="list-style-type: none"> <li>To register the password for accessing the program server where firmware is to be stored.</li> </ul>
Use	
Setting/ Procedure	<ol style="list-style-type: none"> <li>Select [Password].</li> <li>Enter the password (up to 64 characters) on the on-screen keyboard.</li> </ol>

### C. URL

Functions	<ul style="list-style-type: none"> <li>To register the address and directory of the program server where the firmware is to be stored in URL.</li> </ul>
Use	
Setting/ Procedure	<ol style="list-style-type: none"> <li>Select [URL].</li> <li>Enter the URL (up to 256 one-byte characters) on the on-screen keyboard.</li> </ol> <p><b>NOTE</b></p> <ul style="list-style-type: none"> <li>Enter the URL which format suits the protocol to be used.                      When connecting to http <b>http:// (Host name or IP address)/ directory name</b> or <b>https:// (Host name or IP address)/directory name</b>.                      When connecting to ftp <b>ftp:// (Host name or IP address) / directory name</b>.</li> </ul>

### D. FileName

Functions	<ul style="list-style-type: none"> <li>To register the file name of the firmware data to be downloaded.</li> </ul>
Use	
Setting/ Procedure	<ol style="list-style-type: none"> <li>Select [FileName].</li> <li>Enter the file name (up to 63 one-byte characters) on the on-screen keyboard.</li> </ol>

### 10.17.5 Download

Functions	<ul style="list-style-type: none"> <li>• Access the program server according to the Internet ISW setting, and download the firmware.</li> </ul>
Use	<ul style="list-style-type: none"> <li>• To use when updating the firmware via network.</li> </ul>
Setting/ Procedure	<ol style="list-style-type: none"> <li>1. Select [Download].</li> <li>2. Touch [ISW Start] to start downloading the firmware.</li> <li>3. The message to show the status will be displayed on the screen while connecting and transferring data.</li> </ol> <p><b>NOTE</b></p> <ul style="list-style-type: none"> <li>• <b>When it failed to connect to the program server, or failed to download, the error code and the message will be displayed. Check the cause of the error by the error code, and follow the message for resetting. Refer to “Error cord list” for the error codes.</b></li> </ul> <p><a href="#">See P.75</a></p> <ol style="list-style-type: none"> <li>4. When the firmware is normally upgraded, the main body will automatically be restarted to complete the Internet ISW.</li> </ol>



# 11. Enhanced Security

## 11.1 Enhanced Security function setting procedure

### 11.1.1 Procedure

1. Call the Service Mode to the screen.
2. Press the following keys in this order.  
Stop → 0 → Clear
3. Enhanced Security menu will appear.

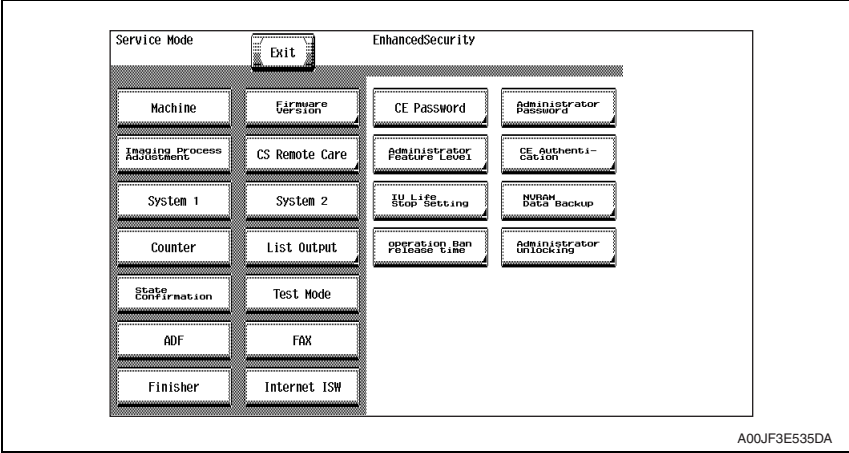

### 11.1.2 Exiting

- Touch the [Exit].

## 11.2 Enhanced Security function tree

Service Mode		Ref. Page
Enhanced Security	CE Password	<a href="#">P.437</a>
	Administrator Password	<a href="#">P.437</a>
	Administrator Feature Level	<a href="#">P.438</a>
	CE Authentication	<a href="#">P.438</a>
	IU Life Stop Setting	<a href="#">P.438</a>
	NVRAM Data Backup	<a href="#">P.439</a>
	Operation Ban release time	<a href="#">P.439</a>
	Administrator unlocking	<a href="#">P.439</a>

### 11.3 Settings in the Enhanced Security

#### 11.3.1 CE Password

Functions	<ul style="list-style-type: none"> <li>To set and change the CE password.</li> </ul>
Use	<ul style="list-style-type: none"> <li>Use to change the CE password.</li> </ul>
Setting/ Procedure	<ul style="list-style-type: none"> <li>Enter the CE password (8 digits) on the on-screen keyboard.</li> <li>The initial setting is "92729272."</li> </ul> <p style="margin-left: 40px;">Current Password : Enter the currently using CE password.                  New Password : Enter the new CE password.                  Re-Input Password : Enter the new CE password again.</p> <p><b>NOTE</b></p> <ul style="list-style-type: none"> <li>When the following setting leads to the Password Rules [ON], the password with the same letters as well as the password which is same as the previous one cannot be changed.                      [Administrator Settings] → [Security Settings]</li> <li>NEVER forget the CE password. When forgetting the CE password, call responsible person of KMBT.</li> </ul>

#### 11.3.2 Administrator Password

Functions	<ul style="list-style-type: none"> <li>To set and change the administrator password.</li> </ul>
Use	<ul style="list-style-type: none"> <li>Use to change the administrator password.</li> <li>Use this function when the administrator forget the administrator password because a new password can be set without entering the current administrator password with this.</li> </ul>
Setting/ Procedure	<ul style="list-style-type: none"> <li>Enter the administrator password (8 digits) on the on-screen keyboard.</li> <li>The initial setting is "12345678."</li> </ul> <p style="margin-left: 40px;">New Password : Enter the new administrator password.                  Re-Input Password : Enter the new administrator password again.</p> <p><b>NOTE</b></p> <ul style="list-style-type: none"> <li>When the following setting leads to the Password Rules [ON], the password with the same letters, the password which is same as the previous one and the password of less than eight digits cannot be changed.                      [Administrator Settings] → [Security Settings]</li> </ul>

bizhub C353/C253/C203

### 11.3.3 Administrator Feature Level

Functions	• To set which modes to be allowed for the administrator to use in Service Mode.																																														
Use	<ul style="list-style-type: none"> <li>• Use when allowing the administrator to use some modes in Service Mode.</li> <li>• The modes allowed for the administrator to use in each setting are as follows.</li> </ul>																																														
	<table border="1" style="width: 100%; border-collapse: collapse;"> <thead> <tr> <th colspan="3">Administrator settings function</th> <th style="text-align: center;">Level 1</th> <th style="text-align: center;">Level 2</th> </tr> </thead> <tbody> <tr> <td rowspan="4" style="vertical-align: middle;">[System Setting] → [Expert Setting]</td> <td rowspan="2">Printer Adjustment</td> <td>Erase Leading Edge</td> <td style="text-align: center;">—</td> <td style="text-align: center;">○</td> </tr> <tr> <td>Leading Edge Adjustment</td> <td style="text-align: center;">—</td> <td style="text-align: center;">○</td> </tr> <tr> <td rowspan="3">Scanner Adjustment</td> <td>Centering</td> <td style="text-align: center;">—</td> <td style="text-align: center;">○</td> </tr> <tr> <td>Horizontal Adjustment</td> <td style="text-align: center;">—</td> <td style="text-align: center;">○</td> </tr> <tr> <td>Vertical Adjustment</td> <td style="text-align: center;">—</td> <td style="text-align: center;">○</td> </tr> <tr> <td rowspan="4">ADF Adjustment</td> <td>Centering</td> <td style="text-align: center;">—</td> <td style="text-align: center;">○</td> </tr> <tr> <td>Original Stop Position</td> <td style="text-align: center;">—</td> <td style="text-align: center;">○</td> </tr> <tr> <td>Centering Auto Adjustment</td> <td style="text-align: center;">—</td> <td style="text-align: center;">○</td> </tr> <tr> <td>Auto Adj. of Stop Position</td> <td style="text-align: center;">—</td> <td style="text-align: center;">○</td> </tr> <tr> <td rowspan="2">[Standard Size Setting]</td> <td>Original Glass Original Size Detect</td> <td style="text-align: center;">—</td> <td style="text-align: center;">○</td> </tr> <tr> <td>Foolscap Size Setting</td> <td style="text-align: center;">—</td> <td style="text-align: center;">○</td> </tr> </tbody> </table>					Administrator settings function			Level 1	Level 2	[System Setting] → [Expert Setting]	Printer Adjustment	Erase Leading Edge	—	○	Leading Edge Adjustment	—	○	Scanner Adjustment	Centering	—	○	Horizontal Adjustment	—	○	Vertical Adjustment	—	○	ADF Adjustment	Centering	—	○	Original Stop Position	—	○	Centering Auto Adjustment	—	○	Auto Adj. of Stop Position	—	○	[Standard Size Setting]	Original Glass Original Size Detect	—	○	Foolscap Size Setting	—
Administrator settings function			Level 1	Level 2																																											
[System Setting] → [Expert Setting]	Printer Adjustment	Erase Leading Edge	—	○																																											
		Leading Edge Adjustment	—	○																																											
	Scanner Adjustment	Centering	—	○																																											
		Horizontal Adjustment	—	○																																											
Vertical Adjustment		—	○																																												
ADF Adjustment	Centering	—	○																																												
	Original Stop Position	—	○																																												
	Centering Auto Adjustment	—	○																																												
	Auto Adj. of Stop Position	—	○																																												
[Standard Size Setting]	Original Glass Original Size Detect	—	○																																												
	Foolscap Size Setting	—	○																																												
Setting/Procedure	<ul style="list-style-type: none"> <li>• The default setting is Prohibit.</li> </ul> <div style="display: flex; justify-content: space-around;"> <span>Level1</span> <span>Level2</span> <span>“Prohibit”</span> </div>																																														

### 11.3.4 CE Authentication

- It will not be displayed when the following settings are set to “ON”.  
 [Administrator Settings] → [Security Setting] → [Enhanced Security Mode] or [Password Rules].

Functions	• To determine whether or not to authenticate CE password as entering Service Mode.	
Use	• Use when authenticating CE password as entering Service Mode.	
	<p><b>NOTE</b></p> <ul style="list-style-type: none"> <li>• <b>For setting the following setting to “ON”, set the CE Authentication to “ON” and change the initial CE password beforehand.</b>              [Administrator Settings] → [Security Setting] → [Enhanced Security Mode] or [Password Rules]</li> </ul>	
Setting/Procedure	<ul style="list-style-type: none"> <li>• The default setting is OFF.</li> </ul> <div style="display: flex; justify-content: space-around;"> <span>ON</span> <span>“OFF”</span> </div>	

### 11.3.5 IU Life Stop Setting

Functions	• To select whether or not to stop a print cycle when the IU reaches its service life.	
Use	• Use to select not to stop the print cycle when the IU reaches its service life.	
Setting/Procedure	The default setting is Stop.	
	“Stop”	No Stop

Adjustment / Setting

### 11.3.6 NVRAM Data Backup

Functions	<ul style="list-style-type: none"> <li>To backup NVRAM data in the main body to the flash memory.</li> </ul>
Use	<ul style="list-style-type: none"> <li>To backup current data in order to prevent data in NVRAM from being erased unexpectedly.</li> <li>To backup data manually. It usually makes backup every hour automatically.</li> <li>Backup data can be restored by following the specified procedure when the trouble (CD3XX) occurred.</li> </ul> <p>Refer to "Troubleshooting" for details on restoration procedure. See P.547</p>
Setting/ Procedure	<ol style="list-style-type: none"> <li>Touch [NVRAM Data Backup].</li> <li>Touch [Start] to start making a backup.</li> <li>Check the message [Backup is completed.], and turn main power switch OFF. Wait for ten seconds or more and turn main power switch back ON.</li> </ol>

### 11.3.7 Operation Ban release time

Functions	<ul style="list-style-type: none"> <li>To set the time that elapses before the machine releases an access lock that is activated after the CE password authentication.</li> </ul>
Use	<ul style="list-style-type: none"> <li>To set the period of time that elapses before the machine releases the access lock, which aims to prevent the unintentional release of the access lock.</li> <li>After the CE password authentication, if the access lock is activated, the lock release timer starts to operate by input the Stop → 0 → 9 → 3 → 1 → 7 in [Meter Count] → [Check Details] → [Coverage Rate] after the main power switch is turned OFF and On. When the timer reaches the time specified in this setting, the access lock is released.</li> </ul>
Setting/ Procedure	<ul style="list-style-type: none"> <li>The default setting is 1 (minutes).</li> </ul> <p style="text-align: center;">1 to 60 (minutes)</p> <p><b>NOTE</b></p> <ul style="list-style-type: none"> <li><b>When Enhanced Security Mode is set to ON in [Administrator Settings] → [Security Settings] → [Enhanced Security Mode], the period of time that can be set in this setting is 5 minutes or more.</b></li> </ul>

### 11.3.8 Administrator unlocking

Functions	<ul style="list-style-type: none"> <li>To release an access lock that is activated after an administrator password authentication.</li> </ul>
Use	<ul style="list-style-type: none"> <li>To release the access lock with service authority when an administrator password authentication fails and the access lock is activated.</li> <li>When the main power switch is turned OFF and ON or the period of time set in the Release Time Settings elapses, the machine releases the access lock that is activated after the administrator password authentication.</li> </ul> <p>In addition to these operations, this setting provides another way to release the access lock.</p>
Setting/ Procedure	<ol style="list-style-type: none"> <li>Touch [Administrator unlocking].</li> <li>Touch [unlocking] to release an access lock.</li> <li>When [OK] is displayed, touch [OK].</li> </ol>

## 12. Billing Setting

### 12.1 Billing Setting function setting procedure

#### 12.1.1 Procedure

1. Call the Service Mode to the screen.
2. Press the following keys in this order.  
Stop → 9
3. Billing Setting menu will appear.

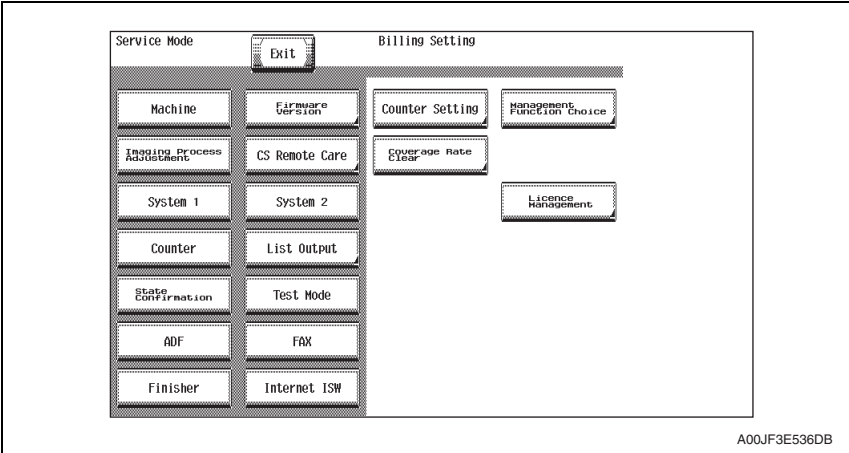

#### 12.1.2 Exiting

- Touch the [Exit].

### 12.2 Billing Setting function tree



Service Mode		Ref. Page	
Billing Setting	Counter Setting	P.441	
	Management Function Choice	P.442	
	Coverage Rate Clear	P.449	
	License Management	Activation	*1
		Deactivation	
		Repair	
Initialize			
Request Code			
	List		

\*1: For details, see the LK-101/102/103 service manual.

## 12.3 Settings in the Billing Setting

### 12.3.1 Counter Setting

Functions	<ul style="list-style-type: none"> <li>To set the counting method for the total counter, size counter and long length paper counter.</li> <li>To set the size regarded as the large size (2 counts.)</li> </ul>																																																													
Use	<ul style="list-style-type: none"> <li>Use to change the counting method for the counters.</li> </ul>																																																													
Setting/ Procedure	<p>Total Counter</p> <p>Mode 1: 1 count per 1 copy cycle (Default: Japan)</p> <p>Mode 2: Large size is double counts (Default: US, Europe, Others1, Others2, Others3, Others4)</p> <p><b>NOTE</b></p> <ul style="list-style-type: none"> <li>The content of this setting is reflected in the count method with the key counter.</li> </ul> <p>Size Counter</p> <ul style="list-style-type: none"> <li>A3/11 x 17 : When it exceeds 279 mm in the main scan direction and 420 mm in the sub scan direction (exceeds 399 mm at fax scan), it is regarded as the large size.</li> <li>A3/B4/11 x 17/8 1/2 x 14 : When it exceeds 215 mm in the main scan direction and 355 mm in the sub scan direction (exceeds 337 mm at fax scan), it is regarded as the large size.</li> <li>A3/11 x 17/B4/8 1/2 x 14/Foolscap: When it exceeds 203 mm in the main scan direction and 330 mm in the sub scan direction (exceeds 313 mm at fax scan), it is regarded as the large size (However the size in the main scan direction changes according to the foolscap size setting.)</li> </ul> <ul style="list-style-type: none"> <li>Not counted (Default: Japan)</li> <li>A3 and 11 x 17 (Default: US)</li> <li>A3, B4, 11 x 17, and 8 1/2 x 14 (Default: Europe, Others 1, Others 2, Others 3, Others 4)</li> <li>A3, B4, Foolscap, 11 x 17, 11 x 14, and 8 1/2 x 14</li> </ul> <p>* Count-up table</p> <table border="1"> <thead> <tr> <th rowspan="2">Copying</th> <th colspan="4">1-Sided</th> <th colspan="4">2-Sided</th> </tr> <tr> <th colspan="2">Sizes other than those specified</th> <th colspan="2">Specified sizes</th> <th colspan="2">Sizes other than those specified</th> <th colspan="2">Specified sizes</th> </tr> <tr> <th rowspan="2">Mode</th> <th colspan="2">Mode</th> <th colspan="2">Mode</th> <th colspan="2">Mode</th> <th colspan="2">Mode</th> </tr> <tr> <th>1</th> <th>2</th> <th>1</th> <th>2</th> <th>1</th> <th>2</th> <th>1</th> <th>2</th> </tr> </thead> <tbody> <tr> <td>Total</td> <td>1</td> <td>1</td> <td>1</td> <td>2</td> <td>2</td> <td>2</td> <td>2</td> <td>4</td> </tr> <tr> <td>Size</td> <td>0</td> <td>0</td> <td>1</td> <td>1</td> <td>0</td> <td>0</td> <td>2</td> <td>2</td> </tr> <tr> <td>2-sided Total</td> <td>0</td> <td>0</td> <td>0</td> <td>0</td> <td>1</td> <td>1</td> <td>1</td> <td>1</td> </tr> </tbody> </table> <p>0: No count; 1: 1 count; 2: 2 counts; 3: 3 counts; 4: 4 counts</p> <p>Long Length Paper Counter Mode</p> <ul style="list-style-type: none"> <li>When printing on the long paper (457.2 mm or over), the counting value will be the total of the value set by the total counter mode and the value by this setting.</li> <li>The default setting is Mode 4.</li> </ul> <p>Mode 1 : + 0 count          Mode 2 : + 1 count          Mode 3 : + 2 counts (457.2 to 915.0 mm will be + 1 count)          Mode 4 : + 3 counts (457.2 to 686.0 mm will be + 1 count, and 686.1 to 915.0 mm will be + 2 count)</p>	Copying	1-Sided				2-Sided				Sizes other than those specified		Specified sizes		Sizes other than those specified		Specified sizes		Mode	Mode		Mode		Mode		Mode		1	2	1	2	1	2	1	2	Total	1	1	1	2	2	2	2	4	Size	0	0	1	1	0	0	2	2	2-sided Total	0	0	0	0	1	1	1	1
Copying	1-Sided				2-Sided																																																									
	Sizes other than those specified		Specified sizes		Sizes other than those specified		Specified sizes																																																							
Mode	Mode		Mode		Mode		Mode																																																							
	1	2	1	2	1	2	1	2																																																						
Total	1	1	1	2	2	2	2	4																																																						
Size	0	0	1	1	0	0	2	2																																																						
2-sided Total	0	0	0	0	1	1	1	1																																																						
Setting/ Procedure	<p>Long Length Paper Counter Mode</p> <ul style="list-style-type: none"> <li>When printing on the long paper (457.2 mm or over), the counting value will be the total of the value set by the total counter mode and the value by this setting.</li> <li>The default setting is Mode 4.</li> </ul> <p>Mode 1 : + 0 count          Mode 2 : + 1 count          Mode 3 : + 2 counts (457.2 to 915.0 mm will be + 1 count)          Mode 4 : + 3 counts (457.2 to 686.0 mm will be + 1 count, and 686.1 to 915.0 mm will be + 2 count)</p>																																																													



### 12.3.2 Management Function Choice

- To set whether or not the following items are to be mounted.  
Key Counter, Management Device (Data controller), Authentication Device, or Vendor

#### NOTE

- It will not be displayed when the following setting is set to "ON".  
[Administrator Settings] → [Security Setting] → [Enhanced Security Mode]
  - When the setting shows that [Management Device 1], [Management Device 2] or [Vendor 2] is mounted, the following applications will be invalid.  
PC FAX transmission / HDD TWAIN/PS Box Operator / PS Scan Direct / PS Job Spooler / Fiery: Scan to Box
- Also, the following setting will be set to "Disable".  
[Administrator Settings] → [Security Setting] → [Management Function Setting] → [Network Function Setting]

#### A. Key Counter IF Vendor

Functions	<ul style="list-style-type: none"> <li>Not used</li> </ul>
Use	
Setting/ Procedure	

#### B. Authentication Device 1

Functions	<ul style="list-style-type: none"> <li>To set whether or not the authentication device 1 is installed.</li> </ul>
Use	<ul style="list-style-type: none"> <li>Set when the authentication device 1 (PageACSES) is mounted.</li> </ul>
Setting/ Procedure	<p><b>NOTE</b></p> <ul style="list-style-type: none"> <li>The setting is available only when user authentication and account track are set "OFF" with [Administrator Settings] → [User Authentication/Account Track] → [General Setting].</li> <li>When the Authentication Device mount setting is set to "mount", make sure that the [IP Address Fax] and [Internet Fax] settings are set to "OFF" with [Service Mode] → [System 2] → [Network Fax Settings].</li> </ul>

#### C. Authentication Device 2

Functions	<ul style="list-style-type: none"> <li>To set whether or not the authentication device 2 is installed.</li> </ul>			
Use	<ul style="list-style-type: none"> <li>Set when the authentication unit (biometric type or card type) is mounted.                     <ul style="list-style-type: none"> <li>Biometrics : Uses biometrics (finger vein) authentication system</li> <li>Card 1 : Uses IC card authentication system</li> <li>Card 2 : Uses loadable device card authentication system</li> </ul> </li> <li>When selecting biometrics, set a film timeout interval.</li> <li>When selecting [Card 1] or [Card 2], a response timeout interval is displayed. (The interval is unchangeable.)</li> <li>When the setting is set to Card 2, the main power switch must be turned OFF and ON to let the new setting take effect.</li> <li>Selecting Card 2, a loadable device driver allows to install.</li> </ul>			
Setting/ Procedure	<p>&lt;Authentication Mode&gt;</p> <table style="width: 100%; text-align: center;"> <tr> <td>Card 1</td> <td>Card 2</td> <td>Biometrics</td> </tr> </table>	Card 1	Card 2	Biometrics
Card 1	Card 2	Biometrics		

**(1) Installing method of the loadable device driver**

- The firmware is updated using the compact flash.

**NOTE**

- **NEVER remove or insert the compact flash card with the machine power turned ON.**

1. Prepare a compact flash on which the driver data of the loadable device to be used was written.
2. Turn OFF the main power switch.
3. Open the rear right door.

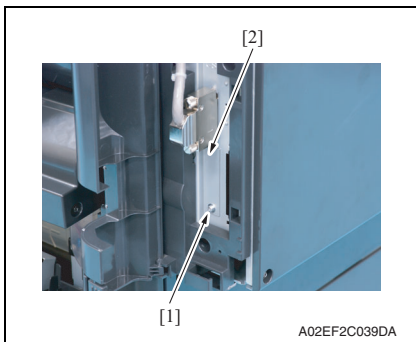

4. Remove the screw [1] and the metal blanking plate [2].

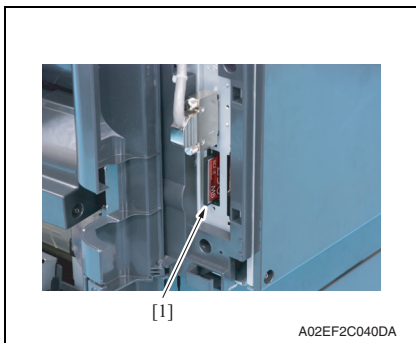

5. Insert the compact flash card [1] into the slot.

6. Turn ON the main power switch and the sub power switch.





7. Select [Yes] on the loadable device driver installation screen.

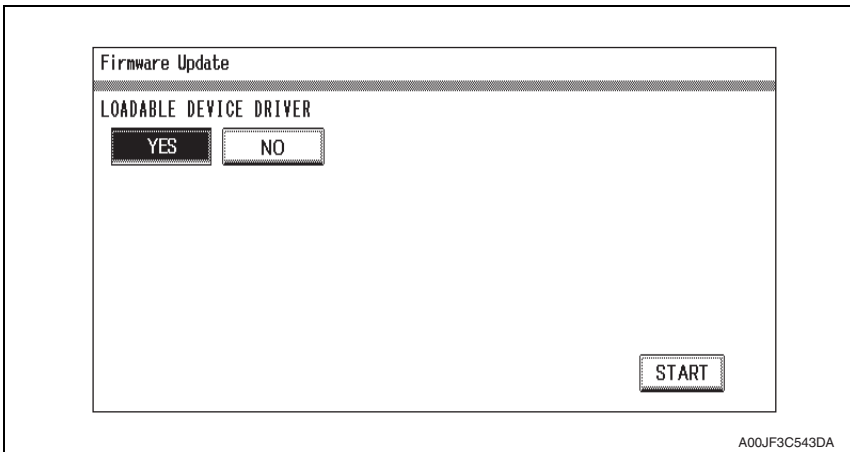

8. Press the [START] to start installing the driver.  
(At this time, the Start key starts blinking red.)
9. Check that the control panel shows the message indicating that the data has been installed correctly ([Downloading Completed]). Check also the check sum value ([Check Sum #####]) shown on the control panel. (The Start key lights blue.)
10. Turn OFF the main power switch.
11. Remove the compact flash card from the slot.
12. Turn ON the main power switch, and close the front door.

**D. Key Counter Only**

Functions	<ul style="list-style-type: none"> <li>To set whether or not the key counter is installed.</li> </ul>
Use	<ul style="list-style-type: none"> <li>Set when the key counter is mounted.</li> <li>Select [Color Mode] and [Message] when the key counter is mounted.</li> </ul>
Setting/ Procedure	<p><b>* Color Mode</b></p> <ul style="list-style-type: none"> <li>When [Mode 1] is set on [Total Counter Mode] after selecting [Billing Setting] → [Counter setting].                     <ul style="list-style-type: none"> <li>Mode 1: 1 count per 1 copy cycle</li> <li>Mode 2: 2 counts per 1 copy cycle</li> <li>Mode 3: 3 counts per 1 copy cycle</li> <li>Mode 4: 4 counts per 1 copy cycle</li> <li>Mode 5: 5 counts per 1 copy cycle</li> </ul> </li> <li>When [Mode 2] is set on [Total Counter Mode] after selecting [Billing Setting] → [Counter setting] and large size is selected on [Large Size Counter Mode]                     <ul style="list-style-type: none"> <li>Mode 1: 2 counts per 1 copy cycle</li> <li>Mode 2: 4 counts per 1 copy cycle</li> <li>Mode 3: 6 counts per 1 copy cycle</li> <li>Mode 4: 8 counts per 1 copy cycle</li> <li>Mode 5: 10 counts per 1 copy cycle</li> </ul> </li> <li>When [Mode 2] is set on [Total Counter Mode] after selecting [Billing Setting] → [Counter setting] and sizes other than large size are selected on [Large Size Counter Mode]                     <ul style="list-style-type: none"> <li>Mode 1: 1 count per 1 copy cycle</li> <li>Mode 2: 2 counts per 1 copy cycle</li> <li>Mode 3: 3 counts per 1 copy cycle</li> <li>Mode 4: 4 counts per 1 copy cycle</li> <li>Mode 5: 5 counts per 1 copy cycle</li> </ul> </li> </ul>
Setting/ Procedure	<p><b>* Message</b> Select the message type when the administrative unit is mounted.</p> <ul style="list-style-type: none"> <li>Type 1: Message for key counter</li> <li>Type 2: Message for card scanning</li> <li>Type 3: Message for ID management</li> <li>Type 4: Message for remote SW</li> </ul> <p><b>* Confirmation copy</b></p> <ul style="list-style-type: none"> <li>Set whether to allow a confirmation copy when a key counter is installed.</li> <li>The default setting is Ban.</li> </ul> <p style="text-align: center;">License <span style="float: right;">"Ban"</span></p> <p><b>* The next job reservation</b></p> <ul style="list-style-type: none"> <li>Set whether to allow the reservation of the next job when a key counter is installed.</li> <li>The default setting is Ban.</li> </ul> <p style="text-align: center;">License <span style="float: right;">"Ban"</span></p> <p><b>NOTE</b></p> <ul style="list-style-type: none"> <li><b>The setting is available only when user authentication and account track are set "OFF" with [Administrator Settings] → [User Authentication/Account Track] → [General Setting].</b></li> </ul>

bizhub C353/C253/C203

Adjustment / Setting

**E. Management Device 1**

Functions	<ul style="list-style-type: none"> <li>To set whether or not the management device 1 is installed.</li> </ul>
Use	<ul style="list-style-type: none"> <li>Set when the management device 1 is mounted.</li> </ul>
Setting/ Procedure	<p><b>NOTE</b></p> <ul style="list-style-type: none"> <li><b>The setting is available only when user authentication is set "OFF" and account track is set "Off" or "Account Name + Password" with [Administrator Settings] → [User Authentication/Account Track] → [General Settings].</b></li> </ul>

**F. Management Device 2**

Functions	<ul style="list-style-type: none"> <li>To set whether or not the management device 2 is installed.</li> </ul>
Use	<ul style="list-style-type: none"> <li>Set when the management device 2 is mounted.</li> </ul>
Setting/ Procedure	<p>* Management Setting</p> <ul style="list-style-type: none"> <li>Select the Management Setting Mode Mode 1: Use contact type device (Logout with ID key is not allowed.) Mode 2: Use non-contact type device (Logout with ID key is allowed.)</li> </ul> <p><b>NOTE</b></p> <ul style="list-style-type: none"> <li><b>The setting is not available when either "External Server" of user authentication, "Password Only" of account track, "Do not synchronize" of user authentication and account track or "Allow" of public user access has been set with [Administrator Settings] → [User Authentication/Account Track] → [General Settings].</b></li> </ul>

**G. Vendor 1**

Functions	<ul style="list-style-type: none"> <li>Not used.</li> </ul>
Use	
Setting/ Procedure	

**H. Vendor 2**

Functions	<ul style="list-style-type: none"> <li>To set whether or not the vendor 2 is installed.</li> </ul>
Use	<ul style="list-style-type: none"> <li>Set when the vendor 2 is mounted.</li> </ul> <p><b>NOTE</b></p> <ul style="list-style-type: none"> <li><b>When using the vendor along with the key counter, inserting the key counter will set it to the “Key Counter Mode” and removing it will set it to the “Vendor Mode”.</b></li> </ul>
Setting/ Procedure	<ul style="list-style-type: none"> <li>Select color mode and message of key counter. (Only for key counter, the type of the color mode and message are same after mounting.)</li> </ul> <p>* Confirmation copy</p> <ul style="list-style-type: none"> <li>Set whether to allow a confirmation copy when a key counter is installed.</li> <li>The default setting is Ban.</li> </ul> <p style="text-align: center;">License <span style="float: right;">“Ban”</span></p> <p>* The next job reservation</p> <ul style="list-style-type: none"> <li>Set whether to allow the reservation of the next job when a key counter is installed.</li> <li>The default setting is Ban.</li> </ul> <p style="text-align: center;">License <span style="float: right;">“Ban”</span></p> <ul style="list-style-type: none"> <li>Select message of vendor.</li> </ul> <p>* Message</p> <ul style="list-style-type: none"> <li>Type 1: Message for key counter</li> <li>Type 2: Message for card scanning</li> <li>Type 3: Message for ID management</li> </ul> <p><b>NOTE</b></p> <ul style="list-style-type: none"> <li><b>The setting is available only when user authentication and account track are set “OFF” with [Administrator Settings] → [User Authentication/Account Track] → [General Setting].</b></li> </ul>

bizhub C353/C253/C203

Adjustment / Setting

**NOTE**

- **Performing the setup for each unit to be mounted will internally change the setting values below. It needs resetting when cancelling the setting in order to set back to “not mounted” because the setting value will remain.**

Setting Item	Vendor 2	Authentication Device 1	Key Counter	Management Device 1	Management Device 2	
Utility	Default Copy Settings	Factory Default		—	—	
	Default Scan/Fax Settings	Factory Default		—	—	
	Copy Operating Screen	[Yes]		—	—	
	Fax Active Screen	Rx Display [Yes]		—	—	
	Scan/Fax Settings Default Tab	Direct Input	—	—	—	
	Left Panel Display Default	[Job List]		—	—	
Administrator Settings	Each Function Setting (When IC-409 is not mounted)	Copy, PC print, Send Data, and Print others will be set to “ON”.	Copy, PC print, Send Data, and Print others will be set to “ON”.	—	Copy will be set to “ON”. PC print, Send Data, and Print others will be set to “OFF”.	
	Each Function Setting (When IC-409 is mounted)	Send Data will be set to “ON”.				
	Administrator Security Level	Prohibit		—	—	
	Weekly Timer ON/OFF Setting	OFF	—	—	—	
	Reset Setting	—	Reset Data After Job will be set to “ON”.	—	—	
	Application Key Settings	When Key 1 is set to My Panel, reset the setting and assign Key 1 to [FAX/SCAN]. When Key 2 is set to My Panel, reset the setting and assign Key 2 to [Copy].		—	When Key 1 is set to My Panel, reset the setting and assign Key 1 to [FAX/SCAN]. When Key 2 is set to My Panel, reset the setting and assign Key 2 to [Copy].	
	Restrict Access to Job Settings	Changing Job Priority, Deleting Other User's Jobs, Registering and Changing Addresses, Changing Zoom Ratio will be set to “Restrict”.		—	—	—
	External Memory Function Settings	—	Save Document and Print Document will be set to “OFF”.		—	—
	ID & Print Settings	—	—	ID & Print will be set to “ON”.	—	—
	Forward TX Setting	OFF		—	—	—
	Line Parameter Setting	—	—	—	—	Receive Mode will be set to “Auto RX”.
	OpenAPI Setting	Access Setting will be set to “Restrict” and Authentication will be changed to “OFF” setting.	Access Setting will be set to “Restrict”.		—	—
IPP Setting	—	IPP Setting will be set to “OFF”, and Accept IPP job will be set to “OFF”.		—	—	

bizhub\_C353/C253/C203

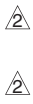

Setting Item	Vendor 2	Authentication Device 1	Key Counter	Management Device 1	Management Device 2
AppleTalk Setting	—	OFF	—	—	—
SMB Setting	—	Scan Setting, Print Setting will be set to "OFF".	—	—	—
E-mail TX (SMTP)	—	E-mail TX Setting, Scan to E-mail, E-mail Notification, Meter Count Notification will be set to "Restrict".	—	—	—
E-mail RX (POP)	—	E-mail RX Setting will be set to "OFF".	—	—	—
LDAP Settings	—	Enabling LDAP will be set to "OFF".	—	—	—
Prefix/Suffix Setting	—	Prefix/Suffix Setting will be set to "OFF".	—	—	—
WebDAV Client Settings	—	WebDAV Client Settings will be set to "OFF".	—	—	—
Web Service Settings Printer setting/ Scanner setting	Printer Setting and Scanner setting will be set to "OFF".		—	Printer Setting and Scanner setting will be set to "OFF".	
Status Notification Setting Notification Item Setting	—	All setting items will be set to "OFF".	—	—	—
Image Log Transfer Settings	[No]	—	—	—	—
Software SW Setting	SW No. 63 will be set to "00" as HEX assignment.	—	—	—	—
Management Function Choice	Confirmation copy will be set to "Ban."	—	—	—	—
FAX	Re-transmission in System-Display Setting will be set to "OFF".	—	—	—	—

Adjustment / Setting

**12.3.3 Coverage Rate Clear**

Functions	<ul style="list-style-type: none"> <li>To clear the coverage rate.</li> </ul>
Use	<ul style="list-style-type: none"> <li>Use to clear the coverage rate.</li> </ul>
Setting/ Procedure	<ul style="list-style-type: none"> <li>The default setting is Unset.</li> </ul> <p style="text-align: center;">Set <span style="float: right;">"Unset"</span></p> <ul style="list-style-type: none"> <li>Touching [END] key will clear the coverage rate.</li> </ul>

## 13. Procedure for resetting

### 13.1 Trouble resetting

Functions	<ul style="list-style-type: none"> <li>If the all troubles occur and the status would not be cleared by turning main power switch OFF and ON again, or opening and closing the front door, clear the status of the machine.</li> </ul>
Use	<ul style="list-style-type: none"> <li>To be used when the status would not be cleared by turning main power switch OFF and ON again, or opening and closing the front door in case of a trouble.</li> </ul>
Setting/ Procedure	<ol style="list-style-type: none"> <li>Turn OFF the main power switch.</li> <li>Turn main power switch ON while pressing the Utility/Counter key.</li> <li>Touch [Trouble Reset].</li> <li>Check to make sure that [OK] is displayed and the it has been reset.</li> <li>After turning off the main power switch, turn it on again more than 10 seconds after and check if the machine starts correctly.</li> </ol>

### 13.2 Contents to be cleared by reset function

Items for clearing		Front door open/close	Main power switch OFF/ON	Trouble resetting	Initialization	
					System Error Clear	Data Clear
Contents to be cleared						
Jam display		○	—	—	○	○
Malfunction display	Rank A	Fusing	—	—	○	—
		Optical	—	—	○	○
	Rank B		○	—	○	—
	Rank C		—	○	○	—
Erratic operation / display		—	○	—	—	—
Utility Mode (Except items on Expert Adjustment.)		—	—	—	—	○
Service Mode (System 1/2)		—	—	—	—	□ *1
Billing Setting	Counter Setting		—	—	—	○
	Management Function Choice		—	—	—	○
Adjustment of the touch panel position		—	—	—	—	○

○: Will be cleared (initialized)

-: Will not be cleared

□ *1: Items to be cleared	
System 1	Marketing Area (Fax Target only)
	Fooscap Size Setting
	Install Date
	Tel/Fax Number
	No Sleep
System 2	Original Size Detection
	HDD
	Image Controller Setting

## 14. Mechanical adjustment

### 14.1 Mechanical adjustment of the scanner section

#### 14.1.1 Adjustment of the scanner motor belt

This adjustment must be made in the following case:

- The scanner motor assy has been removed.
- The scanner drive cables have been rewound.

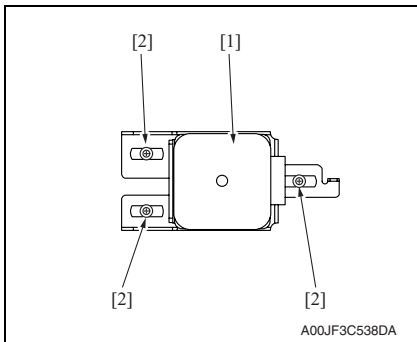

1. Temporarily secure the scanner motor assy [1] with three screws [2].

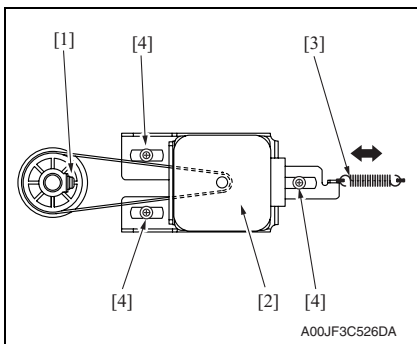

2. With the scanner drive gear set screw [1] located on the right-hand side as shown on the left, slide the scanner motor assy [2] to the left and check that it is returned to the original position by the tension of the spring [3]. Perform this step three times.
3. Tighten the three screws [4] to fix the scanner motor assy into position.



### 14.1.2 Focus positioning of the scanner and mirrors unit

This adjustment must be made in the following case:

- The scanner drive cables have been rewound

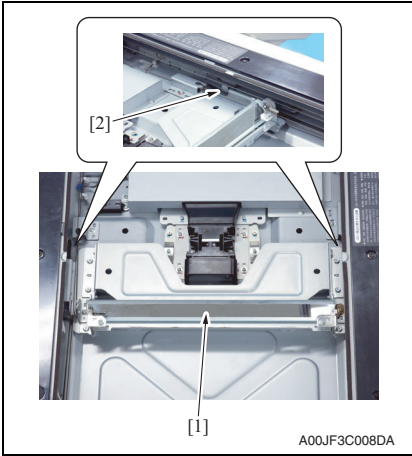

1. Move the mirror unit [1] to the center and push it against the notches [2] on the rail.

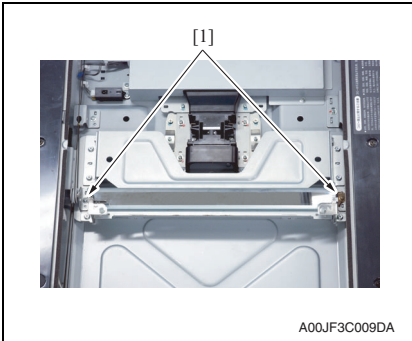

2. When the mirror unit do not push its both sides against the notches, loosen two mirror unit adjustment screws [1] and adjust the mirror unit position until it pushes its both sides against the notches. Tighten the adjustment screw.
3. Then conduct scanner positioning adjustment.

### 14.1.3 Scanner position adjustment

This adjustment must be made in the following case:

- The scanner drive cables have been rewound.
- Focus positioning of the scanner and mirrors unit must be completed.

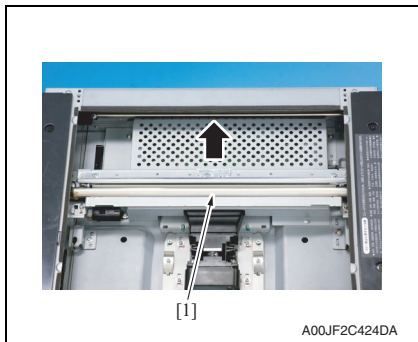

1. Move the scanner assy [1] and the mirror unit to the end of the right.

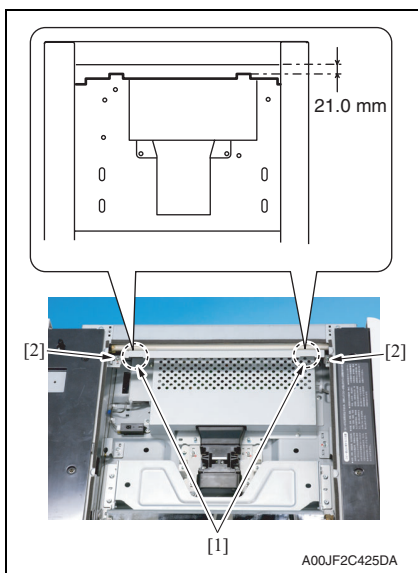

2. Slide the mirror unit until it hits the end of the IR right frame.
3. Provide the length of 21.0 mm between the end of the left indentation [1] on the scanner assy upper surface and the end of the IR right frame upper surface. When the length is ensured, tighten the two screws [2].

4. Mount the original glass moving unit, and adjust the height of the original glass moving unit.  
[See P.454](#)
5. Whenever the scanner drive cables have been removed, be sure to carry out the [Feed Direction Adjustment] procedure.  
[See P.355](#)
6. Perform the following setting.  
[Service Mode] → [ADF] → [Read Pos Adj]  
[See P.32 of the DF-611 service manual.](#)

### 14.1.4 Adjusting the height of the original glass moving unit

This adjustment must be made in the following case:

- When replacing the original glass moving unit.

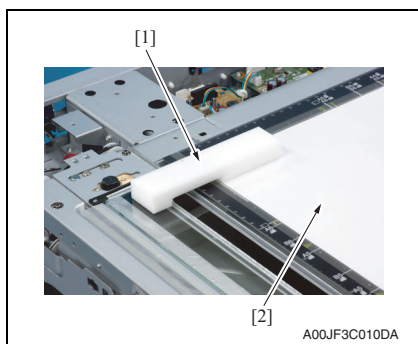

1. Set the height adjustment jig for the original glass moving unit [1]. Insert the paper [2] between the original glass and the height adjusting jig for the original glass moving unit.

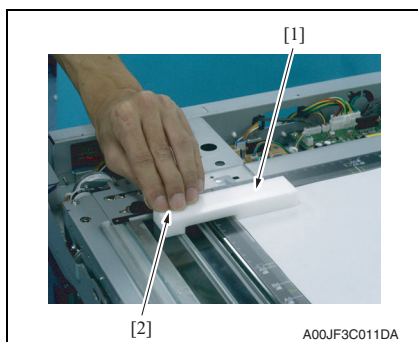

2. Press the height adjusting jig for the original glass moving unit [1] on the original glass moving unit side [2].

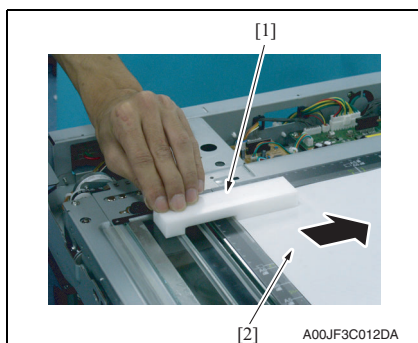

3. Pull the paper [2] while pressing the height adjusting jig for the original glass moving unit [1] and make sure that the paper will not come out.

#### NOTE

- Pull the paper [2] while pressing the height adjusting jig for the original glass moving unit [1] and make sure that the paper will not come out.
4. When the paper comes off, the adjustment of the height is necessary by the following procedure.

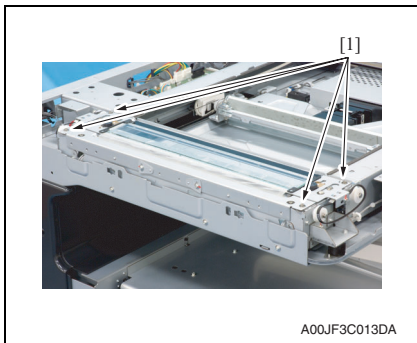

5. Remove four screws [1] from the original glass moving unit.

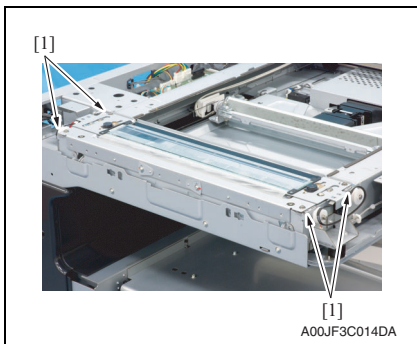

6. Install four spacers [1] and make a height adjustment.

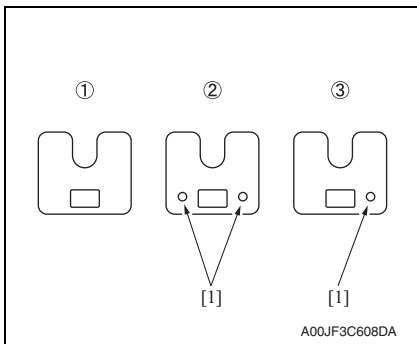

**NOTE**

- Prepare and use the spacers described below as necessary.
  - ① A00J 2903 ##: 0.5 mm thickness
  - ② A00J 2908 ##: 0.2 mm thickness
  - ③ A00J 2909 ##: 0.1 mm thickness
- Each spacer can be identified by the number of holes [1] which are 1.5 mm in diameter.

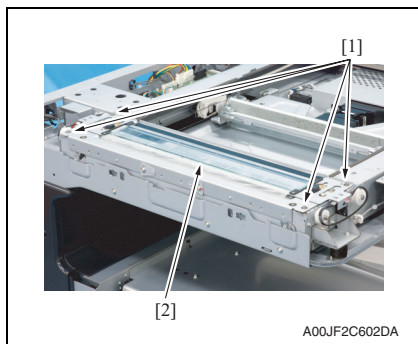

7. Temporarily secure the original glass moving unit [2] with four screws [1].
8. Check the height repeating step 1 to 3.
9. Secure the original glass moving unit with four screws [1].

#### 14.1.5 Adjusting the height of the guide support for the original glass moving unit

This adjustment must be made in the following case:

- Only when original jam, bend, or tilt occurred during original feeding by ADF.

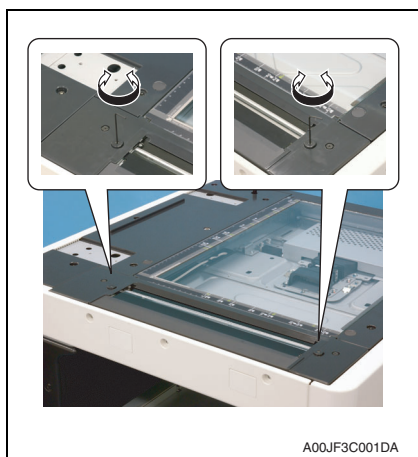

1. Adjust the guide support for the original glass moving unit by rotating the small screws (one on the near side and one on the far side) with the hexagon wrench (1.5 mm) to adjust the height.

**Turning clockwise: Up**

**Turning counterclockwise: Down**

#### NOTE

- Feed a paper with ADF, and adjust so that no original jam, bending, or tilt will occur.

## 14.2 Mechanical adjustment of the paper feed section

### 14.2.1 Skew adjustment of the tray 1, 2

This adjustment must be made in the following case:

- To reduce paper skew that cannot be corrected by the registration loop adjustment when the tray 1 or 2 is within the specifications.

1. Pull out the tray where this adjustment is made.

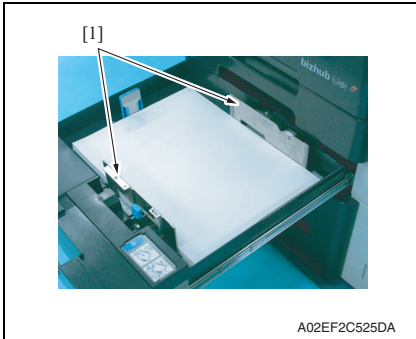

A02EF2C525DA

2. Load the tray with the paper.
3. Move the set of the paper guides [1] until no gap is produced between the both ends of paper and the paper guides.

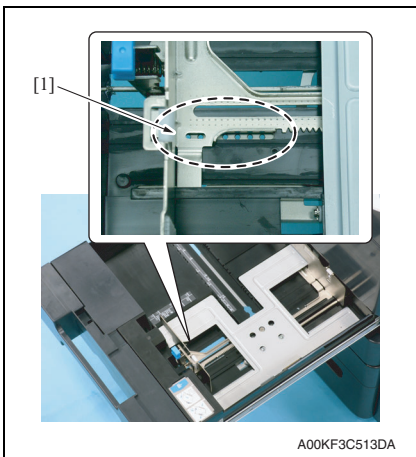

A00KF3C513DA

4. Remove the paper from the tray.
5. Secure the set of paper guides [1] on the tray using a screw (M3 x 8 mm: V121 0308 04).

### 14.2.2 Centering adjustment of the tray 1, 2

**This adjustment must be made in the following case:**

- When an image printed on a copy is displaced from the correct position with the use of the tray1/2.

1. Make a test print and check the amount of misalignment.
2. Pull out the tray where this adjustment is made.

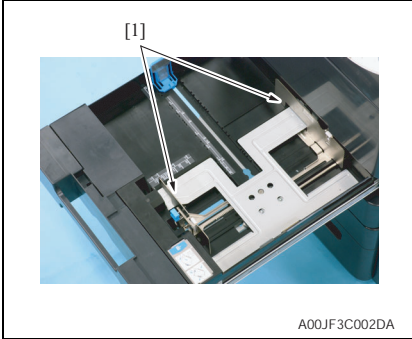

3. Stretch the paper guide [1] to the maximum size position.

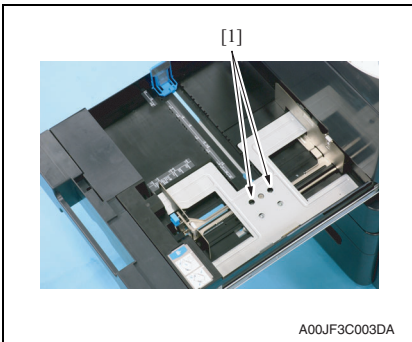

4. Loosen two screws [1].

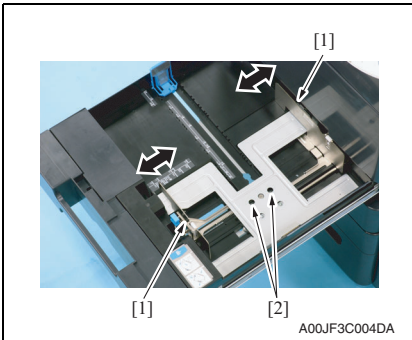

5. Move the paper guide [1] complete according to the amount of the mis-centering you checked in step 1 and adjust the center position of it.
6. Tighten two screws [2].
7. Make another test print and check the amount of misalignment.

### 14.2.3 Adjustment of the manual bypass tray paper size unit

This adjustment must be made in the following case:

- The bypass paper size unit has been removed.

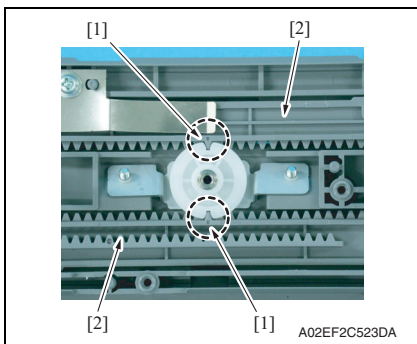

1. Align the match mark [1] on the bypass guide rack gear with the groove on the gear rim at two places and install two bypass guide rack gears [2].

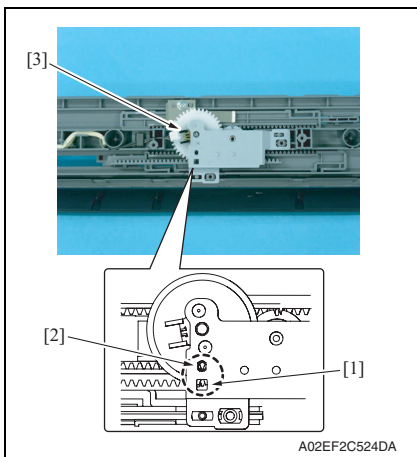

2. When installing the manual CD size sensor assy [3], make sure that the part [1] (pointed by the arrow) on the bypass guide rack gear and the gear's hole [2] on the manual CD size sensor assy are placed in a straight line.
3. Secure the manual CD size sensor assy with two screws.

4. After the bypass paper size unit base has been mounted, check that the lever of the bypass paper size unit moves smoothly in a manner operatively connected to the bypass guide.
5. Call the Service Mode to the screen and select [Machine] → [Manual Bypass Tray Adjustment]. Then, carry out manual bypass tray adjustment.  
[See P.360](#)



### 14.3 PH unit mechanical adjustment

#### 14.3.1 Skew adjustment

This adjustment must be made in the following case:

- When PH unit is replaced.

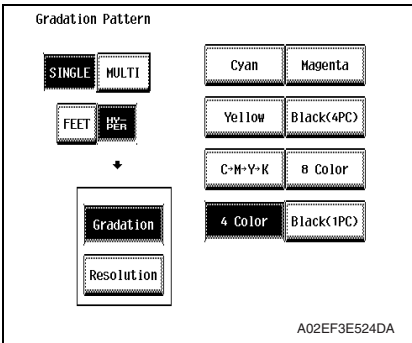

1. Turn ON the main power switch.
2. Select [Service Mode] → [Test Mode] → [Gradation Pattern] and output the test pattern with the following conditions.

**Conditions: SINGLE, HYPER, Gradation, 4 Color**

3. Using the output test pattern, check if each color of CMYK is printed in correct pattern.  
If the pattern is not correct, any troubles such as connecting failure in PH unit of the corresponding color may occur, which should be modified.  
If there is not any problem, proceed to step 4.

4. Touch [Service Mode] → [Imaging Process Adjustment] → [Stabilizer] → [Initialize + Image Stabilization].
5. After image stabilization is completed, display [Service Mode] → [State Confirmation] → [Color Regist] and check if the Step Value: X of each color C, M, Y, is within the specification.

**Specification: within ± 4**

State Confirmation										END
Color Regist										
	Front		Back		Front - Back		Step		Y	
	X	Y	X	Y	X	Y	X	Y		
C	0	0	0	0	0	0	-3	-4		
M	0	0	0	0	0	0	2	-1		
Y	0	0	0	0	0	0	-5	7		

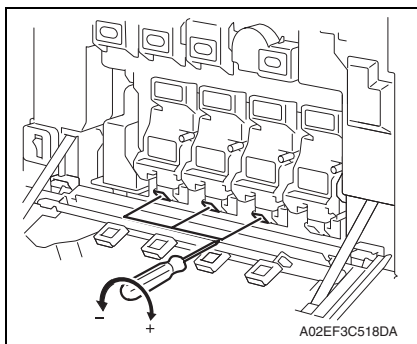

- If either value is out of the specification, follow the procedures shown below to adjust it to satisfy the specification.
  - If the value of all color, C, M, Y satisfy the specification, proceed to step 10.
6. Open the front door.
  7. Turn the skew adjustment dial of the corresponding PH with flathead screwdriver.
    - To the left : When the step value goes - direction
    - To the right : When the step value goes + direction

#### <Adjustment sample>

If the yellow value, among the step values confirmed in step 5, is [-5], which means out of the specification, turn the skew adjustment dial of PH (yellow) to the left (- direction) for 5 clicks.

#### NOTE

- Do not execute the skew adjustment of black PH unit.

8. Close the front door and touch [Imaging Process Adjustment] → [Stabilizer] → [Initialize + Image Stabilization].
9. After image stabilization is completed, display [Service mode] → [State Confirmation] → [Color Regist] again and check if the step value: X of each color C, M, Y is within the specification.

#### NOTE

- Each color's Step value displayed on [Color Regist] changes every time the image stabilization is conducted. Therefore the value may change even if skew adjustment is not made.
  - If either value is out of the specification, repeat step 6 to 9 to continue the adjustment until all C, M, Y colors satisfy the specification.
10. Exit the Service Mode.

Blank Page

# Troubleshooting

## 15. Jam display

### 15.1 Misfeed display

- When a paper misfeed occurs, the misfeed message, misfeed location, and paper location are displayed on the control panel of the machine.

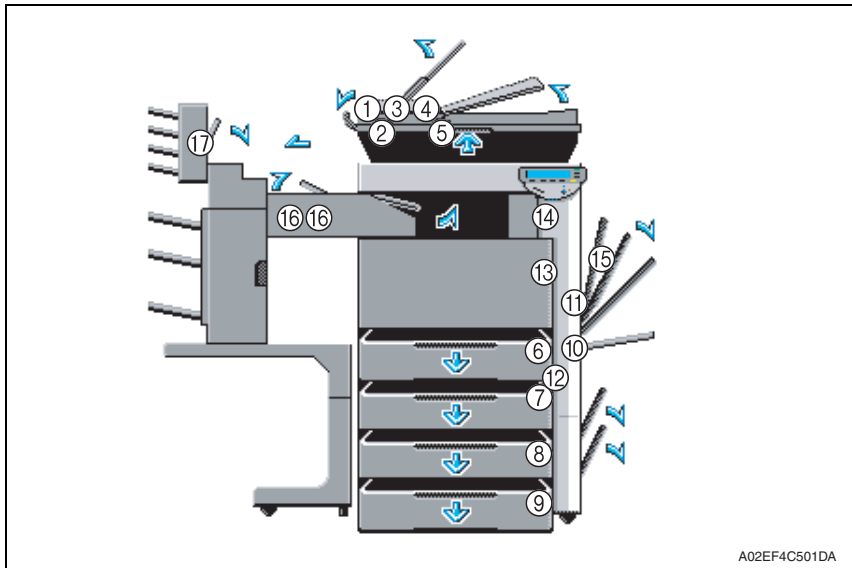

A02EF4C501DA

Display	Code *1	Jam type	Misfeed processing location	Action			
[1]	6601	<a href="#">See P.53 of the DF-611 service manual.</a>					
[2]	6602						
[3]	6603						
[4]	6604						
[5]	6605						
[1], [2], [3], [4], [5]	6606	<a href="#">See P.23 of the PC-104/204 service manual.</a>					
	6607						
[6]	1101				Misfeed at tray 1 feed section	Right door	<a href="#">P.470</a>
[7]	1201				Misfeed at tray 2 feed section	Vertical transport door	<a href="#">P.471</a>
[8]	1301				<a href="#">See P.23 of the PC-104/204 service manual.</a>		
[12]	2001						
[9]	1401						
[12]	2001						
[10]	1001	Misfeed at manual bypass feed section	Right door	<a href="#">P.472</a>			
[11]	9201	Misfeed at duplex pre-registration section	Right door, duplex door	<a href="#">P.473</a>			
[12]	2001	Misfeed at vertical transport section	Right door, vertical transport door	<a href="#">P.474</a>			
[13]	3001	2nd image transfer section	Right door	<a href="#">P.475</a>			

Display	Code *1	Jam type	Misfeed processing location	Action
[14]	3201	Misfeed at exit section	Right door	<a href="#">P.476</a>
[15]	9301	Misfeed at duplex transport section	Duplex door	<a href="#">P.477</a>
—	9901	Controller jam	—	<a href="#">P.478</a>
[16]	7216	<a href="#">See P.73 of the FS-519/PK-515/OT-602 service manual.</a>		
	7218			
	7221			
	7243			
	7281			
[17]	7290	<a href="#">See P.11 of the MT-502 service manual.</a>		

\*1: JAM code is displayed at [Paper Jam History] under [Counter] available from Service Mode.

Regarding jam at paper exit options, jam codes are available by selecting [Service Mode] → [Counter] → [JAM]. To identify misfeed locations, use the jam codes and refer to the above list.

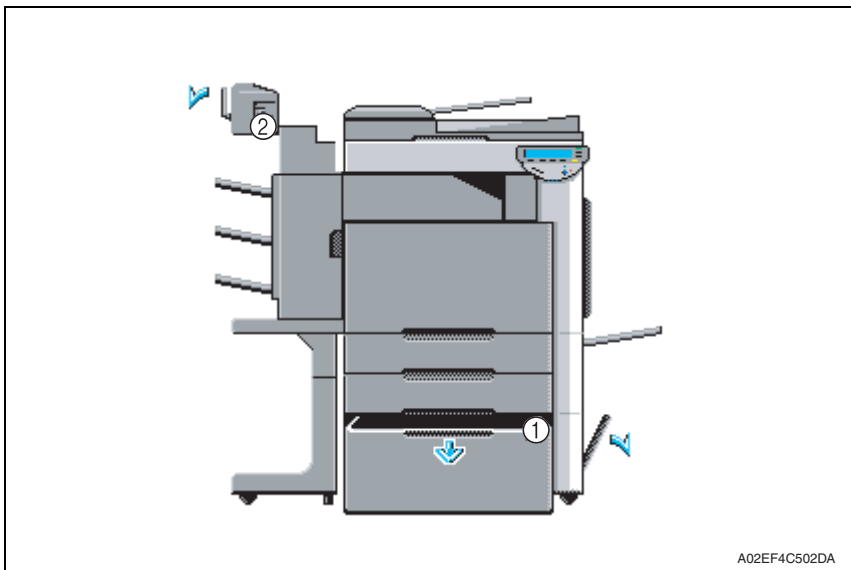

A02EF4C502DA

Display	Code *1	Jam type	Misfeed processing location	Action
[1]	1501	<a href="#">See P.29 of the PC-405 service manual.</a>		
	2001			
[2]	7221	<a href="#">See P.37 of the SD-505 service manual.</a>		
	7225			
	7284			
	7285			

\*1: JAM code is displayed at [Paper Jam History] under [Counter] available from Service Mode.

Regarding jam at paper exit options, jam codes are available by selecting [Service Mode] → [Counter] → [JAM]. To identify misfeed locations, use the jam codes and refer to the above list.

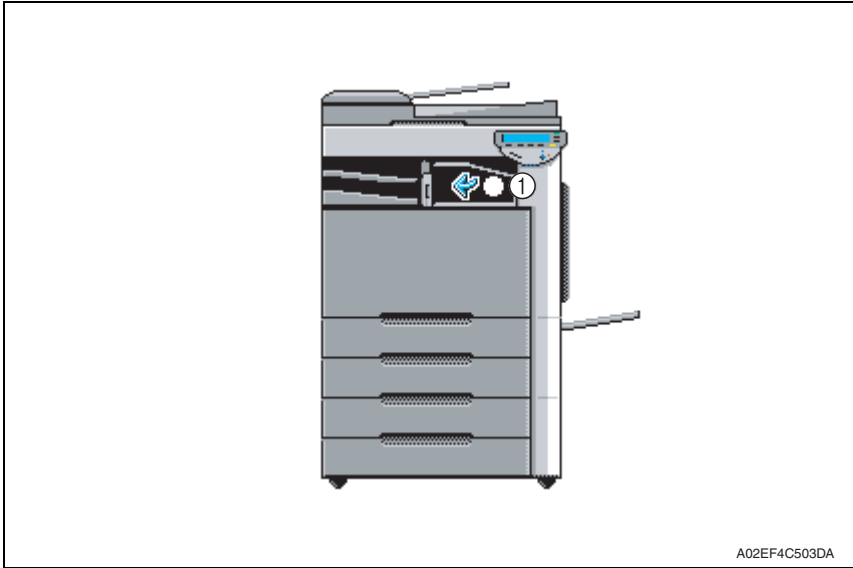

A02EF4C503DA

Display	Code *1	Jam type	Misfeed processing location	Action
[1]	7216	<a href="#">See P.19 of the JS-505 service manual.</a>		

\*1: JAM code is displayed at [Paper Jam History] under [Counter] available from Service Mode.

Regarding jam at paper exit options, jam codes are available by selecting [Service Mode] → [Counter] → [JAM]. To identify misfeed locations, use the jam codes and refer to the above list.

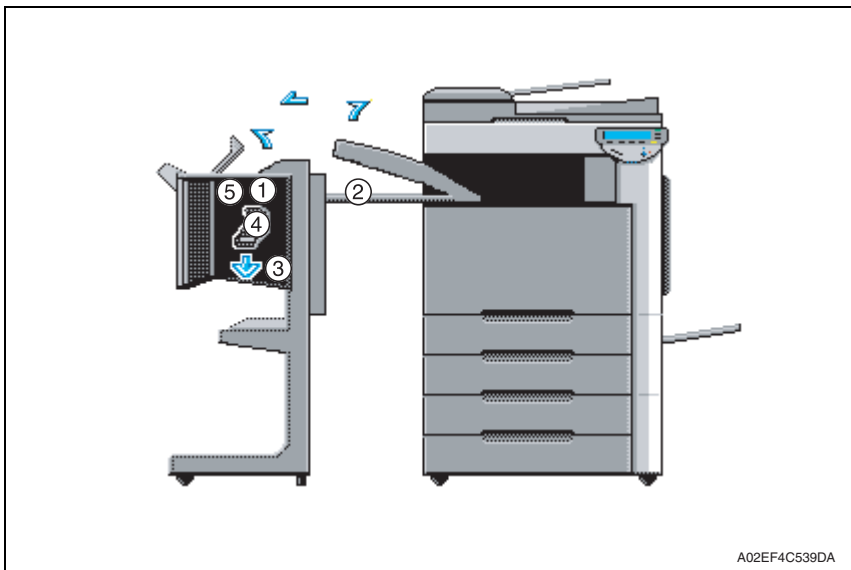

A02EF4C539DA

Display	Code *1	Jam type	Misfeed processing location	Action
[1]	7218	See P.63 of the FS-609/PK-501 service manual.		
[2]	7216			
[3]	7225			
[4]	7281			
[5]	7221			

\*1: JAM code is displayed at [Paper Jam History] under [Counter] available from Service Mode.

Regarding jam at paper exit options, jam codes are available by selecting [Service Mode] → [Counter] → [JAM]. To identify misfeed locations, use the jam codes and refer to the above list.

**15.1.1 Misfeed display resetting procedure**

- Open the corresponding door, clear the sheet of paper misfed, and close the door.





## 15.2 Sensor layout

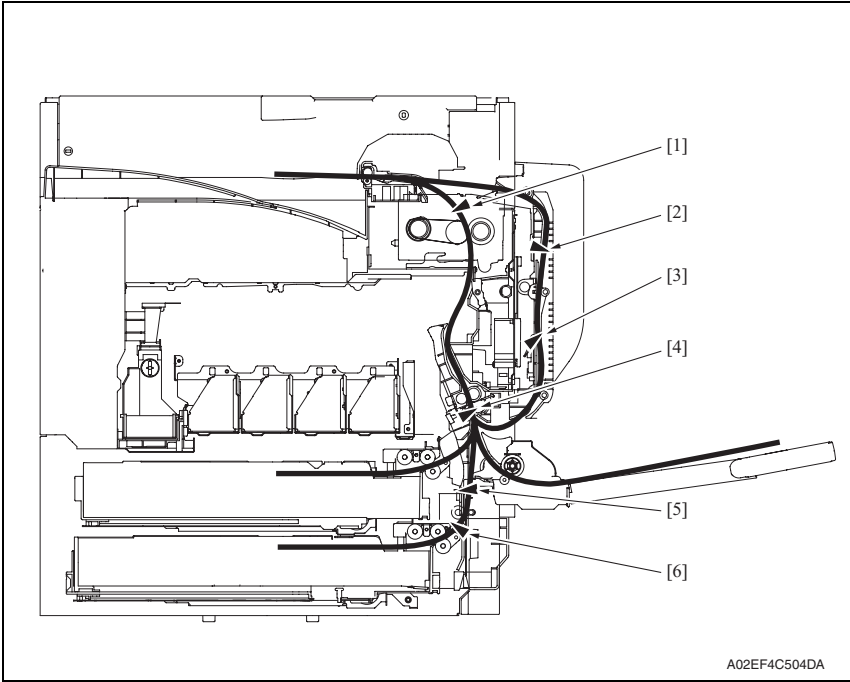

- |                                   |      |   |      |
|-----------------------------------|------|---|------|
| [1] Paper exit sensor             | PS25 | [4] Sensor in front of tim. roller              | PS23 |
| [2] Duplex paper passage sensor/1 | PS33 | [5] Paper feed tray 2 vertical transport sensor | PS16 |
| [3] Duplex paper passage sensor/2 | PS34 | [6] Paper feed tray 2 paper feed sensor         | PS14 |

## 15.3 Solution

### 15.3.1 Initial check items

- When a paper misfeed occurs, first perform the following initial check items.

Check item	Action
Does paper meet product specifications?	Replace paper.
Is the paper curled, wavy, or damp?	Replace paper.
Is a foreign object present along the paper path, or is the paper path deformed or worn?	Clean the paper path and replace if necessary.
Are rolls/rollers dirty, deformed, or worn?	Clean or replace the defective roll/roller.
Are the edge guide and trailing edge stop at the correct position to accommodate the paper?	Set as necessary.
Are the actuators operating correctly?	Correct or replace the defective actuator.

### 15.3.2 Solution when paper curl occurs

Step	Check items/actions	OK	—
1	Turn over the stacked paper in the paper tray.	OK	—
		NG	Go to step 2.
2	Does paper curl occur just after a warm-up has been completed or the sleep mode has been turned OFF?	YES	Go to step 3.
	Does paper curl occur under normal conditions (under conditions other than those mentioned above)?	YES	Go to step 5.
3	1. Call the Service Mode to the screen. 2. Select [System 1] → [Change Warm Up Time]. 3. Change the setting to [Mode 3]. <a href="#">See P.393</a>	OK	—
		NG	Go to step 4.
4	1. Call the Service Mode to the screen. 2. Select [System 1] → [Change Warm Up Time]. 3. Change the setting to [Mode 4]. <a href="#">See P.393</a>	—	—
		—	—
5	1. Call the Service Mode to the screen. 2. Select [Machine] → [Fusing Temperature]. 3. Select a paper type. 4. Change the temperature of Heater Roller to [-10 °C]. <a href="#">See P.345</a>	OK	—
		NG	Go to step 6
6	1. Call the Service Mode to the screen. 2. Select [Machine] → [Fusing Temperature]. 3. Select a paper type. 4. Change the temperature of Heater Roller to [-20 °C]. <a href="#">See P.345</a>	—	—
		—	—

### 15.3.3 Misfeed at tray 1 feed section

#### A. Detection timing

Type	Description
Detection of misfeed at tray 1 feed section	<ul style="list-style-type: none"> <li>The leading edge of the paper does not turn ON the sensor in front of tim. roller (PS23) even after the lapse of a given period of time after the tray 1 starts to feed paper.</li> </ul>
Detection of paper left in tray 1 feed section	<ul style="list-style-type: none"> <li>The paper feed tray 1 chain feed sensor (PS1) is turned ON when the main power switch is turned ON, a door or cover is opened and closed, or a misfeed or malfunction is reset.</li> </ul>
Tray 1 feed section loop registration reversing jam	<ul style="list-style-type: none"> <li>For paper fed from the tray 1, due to a delay in paper arrival, loop forming in front of the timing roller is not complete before the rise timing of the transport motor (M1).</li> </ul>
⚠ Tray 1 feed section image write start signal permit waiting jam	<ul style="list-style-type: none"> <li>For paper fed from the tray1, the image write start signal permit continues to be disabled for a predetermined period of time after the timing of the image write start signal output.</li> </ul>

#### B. Action

Relevant parts	
Transport motor (M1) Paper feed tray 1 paper feed clutch (CL1) Paper feed tray 1 chain feed sensor (PS1) Sensor in front of tim. roller (PS23)	Printer control board (PRCB)

Step	Action	WIRING DIAGRAM	
		Control signal	Location (Electrical component)
1	Initial check items	—	—
2	PS1 I/O check, sensor check	PRCB CN12-8 (ON)	D-8
3	PS23 I/O check, sensor check	PRCB CN1-3 (ON)	D-18
4	CL1 operation check	PRCB CN12-11 (ON)	D-9
5	M1 operation check	PRCB CN34-10 (REM) PRCB CN34-13 (LOCK)	D-23
6	Change PRCB	—	—

**15.3.4 Misfeed at tray 2 feed section**

**A. Detection timing**

Type	Description
Detection of misfeed at tray 2 feed section	<ul style="list-style-type: none"> <li>The leading edge of the paper does not unblock the paper feed tray 2 vertical transport sensor (PS16) even after the lapse of a given period of time after the tray 2 starts to feed paper.</li> </ul>
Detection of paper left in tray 2	<ul style="list-style-type: none"> <li>The paper feed tray 2 vertical transport sensor (PS16) is unblocked when the main power switch is turned ON, a door or cover is opened and closed, or a misfeed or malfunction is reset.</li> <li>The paper feed tray 2 paper feed sensor (PS14) is unblocked when the main power switch is turned ON, a door or cover is opened and closed, or a misfeed or malfunction is reset.</li> </ul>
 Tray 2 feed section image write start signal permit waiting jam	<ul style="list-style-type: none"> <li>For paper fed from the tray2, the image write start signal permit continues to be disabled for a predetermined period of time after the timing of the image write start signal output.</li> </ul>

**B. Action**

Relevant parts	
Transport motor (M1) Paper feed tray 2 paper feed clutch (CL2) Paper feed tray 2 vertical transport clutch (CL3) Paper feed tray 2 paper feed sensor (PS14) Paper feed tray 2 vertical transport sensor (PS16)	Printer control board (PRCB)

Step	Action	WIRING DIAGRAM	
		Control signal	Location (Electrical component)
1	Initial check items	—	—
2	PS14 I/O check, sensor check	PRCB CN9-8 (ON)	D-10
3	PS16 I/O check, sensor check	PRCB CN9-11 (ON)	D-10
4	CL2 operation check	PRCB CN9-19 (ON)	D-11
5	CL3 operation check	PRCB CN9-17 (ON)	D-11
6	M1 operation check	PRCB CN34-10 (REM) PRCB CN34-13 (LOCK)	D-23
7	Change PRCB	—	—



### 15.3.5 Misfeed at manual bypass feed section

#### A. Detection timing

Type	Description
Detection of misfeed at manual bypass feed section	<ul style="list-style-type: none"> <li>The leading edge of the paper does not turn ON the sensor in front of tim. roller (PS23) even after the lapse of a given period of time after the manual bypass tray starts to feed paper.</li> </ul>
Manual bypass feed section loop registration reversing jam	<ul style="list-style-type: none"> <li>For paper fed from the manual bypass, loop forming has not been complete before a sheet enters the timing roller because the rise timing of load to perform registration is earlier than the rise timing of load to form a loop.</li> </ul>
⚠ Manual bypass feed section image write start signal permit waiting jam	<ul style="list-style-type: none"> <li>For paper fed from the manual bypass, the image write start signal permit continues to be disabled for a predetermined period of time after the timing of the image write start signal output.</li> </ul>

#### B. Action

Relevant parts	
Transport motor (M1) Manual paper feed clutch (CL4) Sensor in front of tim. roller (PS23)	Printer control board (PRCB)

Step	Action	WIRING DIAGRAM	
		Control signal	Location (Electrical component)
1	Initial check items	—	—
2	PS23 I/O check, sensor check	PRCB CN1-3 (ON)	D-18
3	CL4 operation check	PRCB CN6-2 (ON)	D-1
4	M1 operation check	PRCB CN34-10 (REM) PRCB CN34-13 (LOCK)	D-23
5	Change PRCB	—	—

### 15.3.6 Misfeed at duplex pre-registration section

#### A. Detection timing

Type	Description
Detection of misfeed at duplex pre-registration section	<ul style="list-style-type: none"> <li>The leading edge of the paper does not turn ON the sensor in front of tim. roller (PS23) even after the lapse of a given period of time after a duplex paper feed sequence has been started.</li> </ul>
Duplex pre-registration section loop registration reversing jam detection	<ul style="list-style-type: none"> <li>For the second-side feed of paper in the duplex mode, loop forming has not been complete before the second side of a sheet enters the timing roller because the rise timing of load to perform registration is earlier than the rise timing of load to form a loop.</li> </ul>
 Duplex pre-registration section image write start signal permit waiting jam	<ul style="list-style-type: none"> <li>For the second-side feed of paper in the duplex mode, the image write start signal permit continues to be disabled for a predetermined period of time after the timing of the image write start signal output.</li> </ul>

#### B. Action

Relevant parts	
Transport motor (M1) Duplex transport motor (M7) Sensor in front of tim. roller (PS23)	Printer control board (PRCB)

Step	Action	WIRING DIAGRAM	
		Control signal	Location (Electrical component)
1	Initial check items	—	—
2	PS23 I/O check, sensor check	PRCB CN1-3 (ON)	D-18
3	M1 operation check	PRCB CN34-10 (REM) PRCB CN34-13 (LOCK)	D-23
4	M7 operation check	PRCB CN4-1 to 4	D-3
5	Change PRCB	—	—

### 15.3.7 Misfeed at tray 2 vertical transport section

#### A. Detection timing

Type	Description
Detection of misfeed at vertical transport section	<ul style="list-style-type: none"> <li>The leading edge of the paper does not turn ON the sensor in front of tim. roller (PS23) even after the lapse of a given period of time after the paper has blocked the paper feed tray 2 vertical transport sensor (PS16).</li> <li>The paper feed tray 2 vertical transport sensor (PS16) is not unblocked even after the lapse of a given period of time after the paper has blocked the PS16.</li> </ul>
Vertical transport section loop registration reversing jam	<ul style="list-style-type: none"> <li>For paper fed from the tray 2, loop forming has not been complete before a sheet enters the timing roller because the rise timing of load to perform registration is earlier than the rise timing of load to form a loop.</li> </ul>

#### B. Action

Relevant parts	
Transport motor (M1) Paper feed tray 2 vertical transport clutch (CL3) Paper feed tray 2 vertical transport sensor (PS16) Sensor in front of tim. roller (PS23)	Printer control board (PRCB)



Step	Action	WIRING DIAGRAM	
		Control signal	Location (Electrical component)
1	Initial check items	—	—
2	PS16 I/O check, sensor check	PRCB CN9-11 (ON)	D-10
3	PS23 I/O check, sensor check	PRCB CN1-3 (ON)	D-18
4	CL3 operation check	PRCB CN9-17 (ON)	D-11
5	M1 operation check	PRCB CN34-10 (REM) PRCB CN34-13 (LOCK)	D-23
6	Change PRCB	—	—

**15.3.8 Misfeed at 2nd image transfer section**

**A. Detection timing**

Type	Description
Detection of misfeed at 2nd image transfer section	<ul style="list-style-type: none"> <li>• A sheet of paper does not turn OFF the sensor in front of tim. roller (PS23) after a predetermined period of time has elapsed since the sheet has turned ON the PS23.</li> <li>• A sheet of paper does not turned ON the paper exit sensor (PS25) after a pre-determined period of time has elapsed since the sheet has turned ON the sensor in front of tim. roller (PS23).</li> </ul>
Detection of paper left in 2nd image transfer section	<ul style="list-style-type: none"> <li>• The sensor in front of tim. roller (PS23) is turned ON when the main power switch is turned ON, a door or cover is opened and closed, or a misfeed or malfunction is reset.</li> </ul>
2nd image transfer section loop registration reversing jam	<ul style="list-style-type: none"> <li>• For paper fed from the tray, loop forming has not been complete before a sheet enters the timing roller because the rise timing of load to perform registration is earlier than the rise timing of load to form a loop.</li> </ul>

**B. Action**

Relevant parts	
Transport motor (M1) Fusing motor (M5) Tim. roller clutch (CL6) Sensor in front of tim. roller (PS23) Paper exit sensor (PS25)	Printer control board (PRCB)



Step	Action	WIRING DIAGRAM	
		Control signal	Location (Electrical component)
1	Initial check items	—	—
2	PS23 I/O check, sensor check	PRCB CN1-3 (ON)	D-18
3	PS25 I/O check, sensor check	—	—
4	CL6 operation check	PRCB CN1-5 (ON)	D-17
5	M1 operation check	PRCB CN34-10 (REM) PRCB CN34-13 (LOCK)	D-23
6	M5 operation check	PRCB CN34-2 (REM) PRCB CN34-5 (LOCK)	D-23
7	Change PRCB	—	—



### 15.3.9 Misfeed at exit section

#### A. Detection timing

Type	Description
Detection of misfeed at exit section	<ul style="list-style-type: none"> <li>The paper exit sensor (PS25) is not turned OFF even after the lapse of a given period of time after the paper has turned ON the PS25.</li> <li>The paper exit sensor (PS25) is not turned ON even after the lapse of a given period of time after the switchback sequence is started.</li> <li>The duplex paper passage sensor/1 (PS33) is not turned ON even after the lapse of a given period of time after the switchback sequence is started.</li> </ul>
Detection of paper left in exit section	<ul style="list-style-type: none"> <li>The paper exit sensor (PS25) is turned ON when the main power switch is turned ON, a door or cover is opened and closed, or a misfeed or malfunction is reset.</li> </ul>

#### B. Action

Relevant parts	
Transport motor (M1) Fusing motor (M5) Switchback motor (M6) Duplex transport motor (M7) Paper exit sensor (PS25) Duplex paper passage sensor/1 (PS33)	Printer control board (PRCB)



Step	Action	WIRING DIAGRAM	
		Control signal	Location (Electrical component)
1	Initial check items	—	—
2	PS25 I/O check, sensor check	—	—
3	PS33 I/O check, sensor check	PRCB CN4-7 (ON)	D-4
4	M1 operation check	PRCB CN34-10 (REM) PRCB CN34-13 (LOCK)	D-23
5	M5 operation check	PRCB CN34-2 (REM) PRCB CN34-5 (LOCK)	D-23
6	M6 operation check	PRCB CN40-10 to 13	D-19
7	M7 operation check	PRCB CN4-1 to 4	D-3
8	Change PRCB	—	—

### 15.3.10 Misfeed at duplex transport section

#### A. Detection timing

Type	Description
Detection of misfeed at duplex transport section	<ul style="list-style-type: none"> <li>A sheet of paper does not unblock the duplex paper passage sensor/2 (PS34) after a predetermined period of time has elapsed since the sheet blocks the duplex paper passage sensor/1 (PS33).</li> <li>A sheet of paper does not unblock the duplex paper passage sensor/1 (PS33) after a predetermined period of time has elapsed since the sheet blocks PS33.</li> <li>A sheet of paper does not block the duplex paper passage sensor/2 (PS34) after a predetermined period of time has elapsed since the sheet unblocks PS34.</li> </ul>
Detection of paper left in duplex transport section	<ul style="list-style-type: none"> <li>The duplex paper passage sensor/1 (PS33) is blocked, or the duplex paper passage sensor/2 (PS34) is unblocked when the main power switch is turned ON, a door or cover is opened and closed, or a misfeed or malfunction is reset.</li> </ul>

#### B. Action

Relevant parts	
Switchback motor (M6) Duplex transport motor (M7) Duplex paper passage sensor/1 (PS33) Duplex paper passage sensor/2 (PS34)	Printer control board (PRCB)



Step	Action	WIRING DIAGRAM	
		Control signal	Location (Electrical component)
1	Initial check items	—	—
2	PS33 I/O check, sensor check	PRCB CN4-7 (ON)	D-4
3	PS34 I/O check, sensor check	PRCB CN4-10 (ON)	D-4
4	M6 operation check	PRCB CN40-10 to 13	D-19
5	M7 operation check	PRCB CN4-1 to 4	D-3
6	Change PRCB	—	—



### △ 15.3.11 Controller jam

#### A. Detection timing

Type	Description
Controller jam	• A control erratic operation as it relates to the duplex unit occurs.
	• A stop command (a command to effect a forced stop) is received.
	• A media error (wrong type or size of paper) occurs during a 2-sided print cycle.

#### B. Action

Relevant parts	
MFP board (MFPB)	Printer control board (PRCB)

Step	Action	WIRING DIAGRAM	
		Control signal	Location (Electrical component)
1	Initial check items	—	—
2	Check for the paper left in the machine.	—	—
3	Check to see if the size or type of the paper specified on the control panel or printer driver coincides with that of the paper actually loaded.	—	—
4	One possible cause is a control erratic operation. So, turn OFF and ON the main power switch and run the print cycle again.	—	—
5	Upgrade the firmware.	—	—
6	Change PRCB	—	—
7	Change MFPB	—	—

## 16. Malfunction code

### 16.1 Alert code

- The machine's CPU performs a self-diagnostics function that, on detecting a malfunction, gives the corresponding warning code and maintenance call mark on the control panel.
- Touching the maintenance call mark will display the corresponding warning code on the state confirm screen.

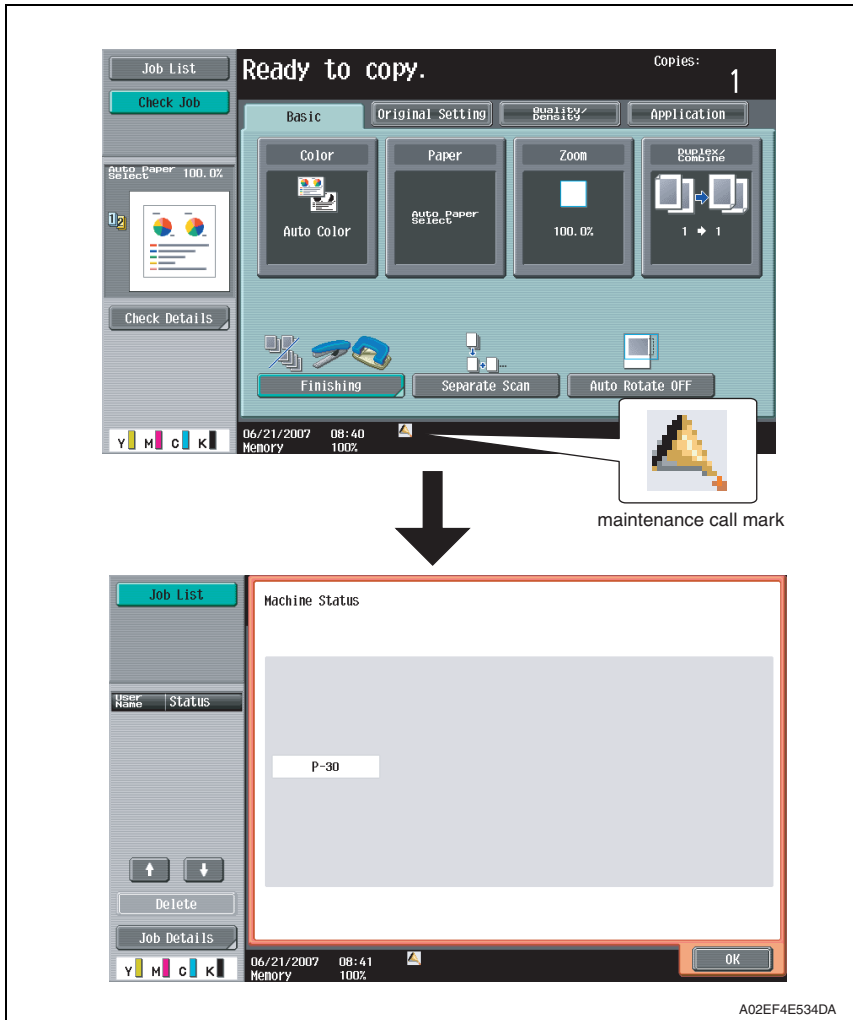

### 16.1.1 Alert code list

- If an image stabilization or scanner fault occurs, the corresponding warning code appears.

Code	Item	Description
S-1	CCD gain adjustment failure	<ul style="list-style-type: none"> <li>• It is detected that the CCD clamp gain adjustment value is faulty.</li> </ul>
D-1	Split line detect	<ul style="list-style-type: none"> <li>• While recovering from the power save mode or when the main/sub power switch is ON, it detects whether or not stain exist at the original glass moving unit when the ADF is closed. This warning will be displayed if the original is set to ADF when stain exist.</li> <li>• The thin line detection level and the warning display can be changed by the following setting. [Service Mode] → [System 2] → [Thin line Detect. Setting]</li> </ul>
D-2	Read guide trouble	<ul style="list-style-type: none"> <li>• While recovering from the power save mode or when the main/sub power switch is ON, it detects whether or not stain exist at the scanning guide when the ADF is closed. This warning will be displayed if the original is set to ADF when stain exist.</li> <li>• This setting is valid only when the [Detection during Paper Passing] available from the following setting is set to one between 2 and 6. [Service Mode] → [System 2] → [Split Line Detect. Setting]</li> </ul>
P-5	IDC sensor (front) failure	<ul style="list-style-type: none"> <li>• When adjusting the IDC sensor, output voltage detected for all sample patterns are specified value or more.</li> <li>• When adjustment is complete, sensor's output voltage with selected light intensity is specified value or under.</li> <li>• During image stabilization (gamma correction control), detected output value for IDC sensor did not go below threshold (half the value of what is detected by IDC sensor on the belt surface) for three consecutive times (position of the pattern end is not detected).</li> <li>• During image stabilization (gamma correction control), sensor's output value of each color for hyper 0 gradation after the primary approximation is half the detection level on the belt surface or under</li> </ul>
P-28	IDC sensor (rear) failure	
P-6	Cyan imaging unit failure	<ul style="list-style-type: none"> <li>• All density readings taken from the density pattern produced on the transfer belt are 1.0 g/m<sup>2</sup> (IDC sensor photo receiver output) or less during max. density adjustment (Vg/Vdc adjustment).</li> </ul>
P-7	Magenta imaging unit failure	
P-8	Yellow imaging unit failure	
P-9	Black imaging unit failure	
P-21	Color regist test pattern failure	<ul style="list-style-type: none"> <li>• The number of points detected in the main scan direction is more or less than the specified value during main scan direction registration correction.</li> <li>• The number of points detected in the sub scan direction is more or less than the specified value during sub scan direction registration correction.</li> </ul>

Code	Item	Description
P-22	Color regist adjust failure	<ul style="list-style-type: none"> <li>• The color shift amount is greater than the specified range during main scan direction registration correction.</li> <li>• The color shift amount is greater than the specified range during sub scan direction registration correction.</li> <li>• On the color shift test pattern, the maximum and minimum deviations detected in the main and sub scan directions go over the predetermined value.</li> </ul>
P-27	Secondary transfer ATVC failure	<ul style="list-style-type: none"> <li>• An abnormal average value is detected during an adjustment of the second image transfer ATVC value.</li> </ul>
P-30	Color PC drive sensor malfunction	<ul style="list-style-type: none"> <li>• The output from the color PC drive main and sub sensors remains unchanged for a continuous period of 1,000 ms while the color PC motor is turning stably and the lock signal is active (LOW-0).</li> </ul>
P-31	Black PC drive sensor malfunction	<ul style="list-style-type: none"> <li>• The output from the black PC drive main and sub sensors remains unchanged for a continuous period of 1,000 ms while the transport motor is turning stably and the lock signal is active (LOW-0).</li> </ul>

## 16.2 Solution

### 16.2.1 S-1: CCD gain adjustment failure

Relevant parts	
Scanner assy	CCD sensor unit Image processing board (IPB)

Step	Action
1	Correct the harness connection between CCDB and IPB if faulty.
2	Check for possible extraneous light and correct as necessary.
3	Clean the lens, mirrors, CCD surface, and shading sheet if dirty.
4	Correct reflective mirror of the scanner if faulty, or change scanner.
5	Change CCD sensor unit.
6	Change IPB.

### 16.2.2 D-1: Split line detect

Relevant parts	
Original glass moving unit	Image processing board (IPB) Printer control board (PRCB)

Step	Action
1	Wipe clean the glass surface of the original glass moving unit.
2	Correct the harness connection between IPB and PRCB if faulty.
3	Change original glass moving unit.
4	Change IPB.
5	Change PRCB.

### 16.2.3 D-2: Read guide trouble

Relevant parts	
ADF scanning guide (DF-611)	

Step	Action
1	Wipe clean the surface of the ADF scanning guide with a cleaning pad, if it is dirty. <a href="#">See P.13 of the DF-611 service manual.</a>

**16.2.4 P-5: IDC sensor (front) failure**

**16.2.5 P-28 IDC sensor (rear) failure**

Relevant parts	
IDC registration sensor/MK (IDCS/MK) IDC registration sensor/YC (IDCS/YC)	Printer control board (PRCB) High voltage unit (HV) Transfer belt unit

Step	Action
1	Wipe clean the surface of the transfer belt with a soft cloth, if it is dirty.
2	Change the image transfer belt unit if the transfer belt is damaged.
3	Reinstall or reconnect IDCS/MK or IDCS/YC, sensor shutter or connector, if it is installed or connected improperly.
4	Clean IDCS/MK or IDCS/YC if it is dirty.
5	Check the HV connector for proper connection and correct as necessary.
6	Open/close the front door, run an image stabilization sequence, and select [State Confirmation] → [Level History 1] to check the IDC value. IDC1: IDCS/MK, IDC2: IDCS/CY If the value is 1.0 V or less, change IDCS/MK or IDCS/CY.
7	Change PRCB.

**16.2.6 P-6: Cyan imaging unit failure**

**16.2.7 P-7: Magenta imaging unit failure**

**16.2.8 P-8: Yellow imaging unit failure**

**16.2.9 P-9: Black imaging unit failure**

Relevant parts	
Imaging unit /C Imaging unit /M Imaging unit /Y Imaging unit /K	Transfer belt unit High voltage unit (HV) Printer control board (PRCB)

Step	Action
1	Select [Imaging Process Adjustment] → [D Max Density] and, if the setting value is negative, readjust.
2	Check the drive transmission portion of the Imaging Unit and correct as necessary.
3	Clean the IDC registration sensor/MK (IDCS/MK) or IDC registration sensor/CY (IDCS/CY) window if dirty.
4	Clean the contact of the imaging unit connector if dirty.
5	Check the HV connector for proper connection and correct as necessary.
6	Change imaging unit.
7	Change the transfer belt unit.
8	Change PRCB.



**16.2.10 P-21: Color regist test pattern failure**

Relevant parts	
Transfer belt unit PH unit	Printer control board (PRCB)

Step	Action
1	Wipe clean the surface of the transfer belt with a soft cloth, if it is dirty.
2	Change the image transfer belt unit if the transfer belt is damaged.
3	Change the PH unit.
4	Change PRCB.

**16.2.11 P-22: Color regist adjust failure**

Relevant parts	
IDC registration sensor /MK (IDCS/MK) IDC registration sensor/CY (IDCS/CY)	Printer control board (PRCB)

Step	Action
1	Slide out the imaging unit and reinstall it in position.
2	Reinstall or reconnect IDCS/MK or IDCS/CY if it is installed or connected improperly.
3	Check the vertical transport guide for installed position and correct as necessary.
4	Change PRCB.

**16.2.12 P-27: Secondary transfer ATVC failure**

Relevant parts	
High voltage unit (HV) Printer control board (PRCB)	Image transfer entrance guide 2nd image transfer assy Transfer belt unit

Step	Action
1	Check roller opposed to the 2nd image transfer roller is grounded. Clean the joint or correct if necessary.
2	Check the image transfer entrance guide for proper installation and correct if necessary.
3	Check that the spring does not come off during the pressure operation of the 2nd transfer roller and correct if necessary.
4	Check the contact at the joint of the 2nd image transfer assy and HV. Clean the joint or correct if necessary.
5	Change the transfer belt unit.
6	Change HV.
7	Change PRCB.

**16.2.13 P-30: Color PC drive sensor malfunction**

Relevant electrical parts	
Color PC drive main sensor (PS27)	Main drive unit
Color PC drive sub sensor (PS28)	Printer control board (PRCB)

Step	Action
1	Perform the faulty sensor check procedure. *1
2	Check the sensor, for which a faulty condition has been checked, for installed position and proper connector connection.
3	Wipe the sensor, for which a faulty condition has been checked, clean of dirt if any.
4	If P-30 occurs again, change the main drive unit.
5	Change PRCB.

\*1: Faulty sensor check procedure

1. Open the front door and turn ON the main power switch of the machine.
2. Call the [Sensor Check] screen to the screen by way of Service Mode.  
For details how to display, see "Adjustment /Setting."  
See P.409
3. Close the front door and start [Stabilization].
4. During the stabilization sequence, check to see if the values of the phase detection sensors (color PC drive main/sub sensors) change.
5. A sensor is faulty if its value does not change.

**16.2.14 P-31: Black PC drive sensor malfunction**

Relevant parts	
Black PC drive main sensor (PS29)	Main drive unit
Black PC drive sub sensor (PS30)	Printer control board (PRCB)

Step	Action
1	Perform the faulty sensor check procedure. *1
2	Check the sensor, for which a faulty condition has been checked, for installed position and proper connector connection.
3	Wipe the sensor, for which a faulty condition has been checked, clean of dirt if any.
4	If P-31 persists, change the main drive unit.
5	Change PRCB.

\*1: Faulty sensor check procedure

1. Open the front door and turn ON the main power switch of the machine.
2. Call the [Sensor Check] screen to the screen by way of Service Mode.  
For details how to display, see "Adjustment /Setting."  
See P.409
3. Close the front door and start [Stabilization].
4. During the stabilization sequence, check to see if the values of the phase detection sensors (black PC drive main/sub sensors) change.
5. A sensor is faulty if its value does not change.

### 16.3 Trouble code



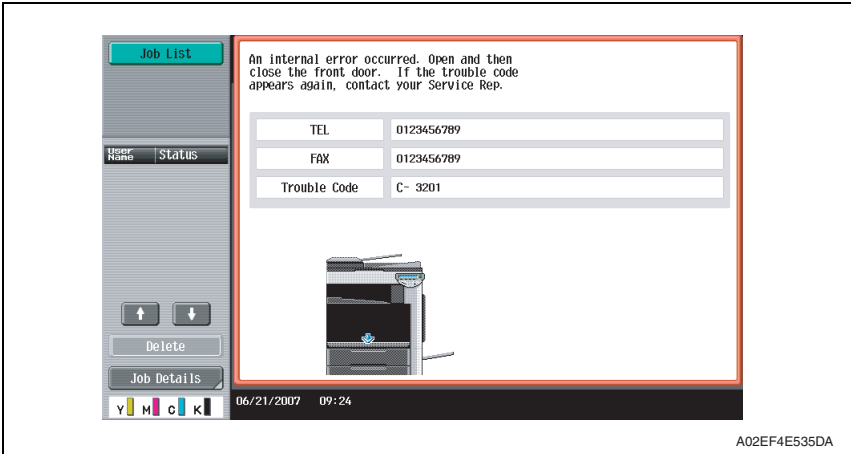



- The machine's CPU performs a self-diagnostics function that, on detecting a malfunction, gives the corresponding malfunction code on the control panel.



#### 16.3.1 Trouble code list

\* For the details of the malfunction codes of the options, see the Service Manual for the corresponding option.

Code	Item	Detection timing	Trouble isolation compliant unit	Rank
C0001	LCT connection failed	<a href="#">See P.34 of the PC-405 service manual.</a>	—	C
C0202	Tray 1 feeder up/down abnormality	<ul style="list-style-type: none"> <li>The paper feed tray 1 upper limit sensor is not blocked even after the lapse of a given period of time after the lifting motion has been started.</li> </ul>	Tray 1	B
C0204	Tray 2 feeder up/down abnormality	<ul style="list-style-type: none"> <li>The paper feed tray 2 upper limit sensor is not blocked even after the lapse of a given period of time after the lifting motion has been started.</li> </ul>	Tray 2	B
C0206	Tray 3 feeder up/down abnormality	<a href="#">See P.28 of the PC-104/204 service manual.</a>	Tray 3	B
C0208	Tray 4 feeder up/down abnormality		Tray 4	B
C0209	LCT elevator motor malfunction	<a href="#">See P.34 of the PC-405 service manual.</a>	LCT	B
C0210	LCT ascent motion failure		LCT	B

Code	Item	Detection timing	Trouble isolation compliant unit	Rank
C0211	Manual feed up/down abnormality	<ul style="list-style-type: none"> <li>The manual lift-up position sensor is not unblocked even when the transport motor has turned for a given number of pulses after the sequence to move the paper lifting plate from the standby position to the feed position was started.</li> <li>The manual lift-up position sensor is not blocked even when the transport motor has turned for a given number of pulses after the sequence to move the paper lifting plate from the feed position to the standby position was started.</li> </ul>	manual	B
C0212	LCT ejection failure	See P.34 of the PC-405 service manual.	LCT	B
C0213	LCT shift gate malfunction		LCT	B
C0214	LCT shifting failure		LCT	B
C0215	LCT shift motor malfunction		LCT	B
C0301	Suction fan motor's failure to turn	<ul style="list-style-type: none"> <li>The fan lock signal remains HIGH for a pre-determined continuous period of time while the motor remains stationary.</li> </ul>	—	B
C0351	Paper cooling fan motor's failure to turn	<ul style="list-style-type: none"> <li>The fan lock signal remains HIGH for a pre-determined continuous period of time while the motor remains stationary.</li> </ul>	—	B
C1004	FNS communication error	See P.79 of the FS-519/PK-515/OT-602 service manual. See P.22 of the JS-505 service manual.	—	C
 C1180	Transport system drive malfunctions	See P.69 of the FS-609/PK-501 service manual.	—	B
 C1181	Paddle motor malfunctions		—	B
C1182	Shift motor mechanism failure	See P.22 of the JS-505 service manual.	—	B
 C1183	Finishing option elevator drive malfunction	See P.79 of the FS-519/PK-515/OT-602 service manual. See P.69 of the FS-609/PK-501 service manual.	—	B
 C1190	Finishing option aligning bar moving mechanism malfunction 1	See P.79 of the FS-519/PK-515/OT-602 service manual.	—	B
C1191	Finishing option aligning bar moving mechanism malfunction 2		—	B
 C1192	Front aligning plate motor malfunctions	See P.69 of the FS-609/PK-501 service manual.	—	B
 C1193	Rear aligning plate motor malfunctions		—	B
C11A0	Paper holding drive failure	See P.79 of the FS-519/PK-515/OT-602 service manual.	—	B
C11A1	Finishing option exit roller pressure/retraction failure		—	B



Code	Item	Detection timing	Trouble isolation compliant unit	Rank
C11A2	Saddle exit roller pressure/retraction failure	See P.42 of the SD-505 service manual.	—	B
C11A3	Shutter drive failure	See P.79 of the FS-519/PK-515/OT-602 service manual.	—	B
C11A4	Saddle exit motor failure Booklet exit motor malfunctions	See P.42 of the SD-505 service manual. See P.69 of the FS-609/PK-501 service manual.	—	B
C11A5	Saddle in & out guide motor failure	See P.42 of the SD-505 service manual.	—	B
C11A6	Saddle layable guide drive failure		—	B
C11B0	Finishing option stapler unit CD drive failure	See P.79 of the FS-519/PK-515/OT-602 service manual.	—	B
C11B1	Stapler unit slide motor malfunctions	See P.69 of the FS-609/PK-501 service manual.	—	B
C11B2	Finishing option stapling mechanism malfunction 1	See P.79 of the FS-519/PK-515/OT-602 service manual.	—	B
C11B4	Stapler/folding motor malfunctions	See P.69 of the FS-609/PK-501 service manual.	—	B
C11B5	Side staple 1 drive failure	See P.42 of the SD-505 service manual.	—	B
C11B6	Side staple 2 drive failure		—	B
C11C0	Punch motor malfunction	See P.79 of the FS-519/PK-515/OT-602 service manual.	—	B
C11C1	Punch control board malfunctions	See P.69 of the FS-609/PK-501 service manual.	—	C
C11C2	Punch side registration motor malfunctions		—	C
C11C3	Punch motor malfunctions		—	C
C11C5	Punch sensor malfunctions		—	C
C11D0	Crease motor drive failure		See P.42 of the SD-505 service manual.	—
C11E0	Route switch malfunction	See P.22 of the JS-505 service manual.	—	B
C1301	Finishing option cooling fan motor failure	See P.79 of the FS-519/PK-515/OT-602 service manual.	—	B
C1401	Backup RAM failure	See P.69 of the FS-609/PK-501 service manual.	—	C

Code	Item	Detection timing	Trouble isolation compliant unit	Rank
C2151	Secondary transfer roller pressure welding alienation	<ul style="list-style-type: none"> <li>During a retraction operation of the 2nd image transfer roller, the 2nd image transfer welding alienation sensor cannot detect the 2nd image transfer roller at its retracted position within a predetermined period of time after the 2nd image transfer retraction motor starts rotating.</li> <li>During a pressure operation of the 2nd image transfer roller, the 2nd image transfer welding alienation sensor cannot detect the 2nd image transfer roller at its pressed position within a predetermined period of time after the 2nd image transfer retraction motor starts rotating.</li> </ul>	—	B
C2152	Transfer belt pressure welding alienation	<ul style="list-style-type: none"> <li>During a retraction operation of the transfer belt, the transfer belt retraction sensor cannot detect the transfer belt at its retracted position within a predetermined period of time after the transfer belt retraction clutch is turned ON.</li> <li>During a pressure operation of the transfer belt, the transfer belt retraction sensor cannot detect the transfer belt at its pressed position within a predetermined period of time after the transfer belt clutch is turned ON.</li> </ul>	—	B
C2164	PC charge malfunction	<ul style="list-style-type: none"> <li>When electrostatic charge output is ON, electrostatic charge leak detection system continues to detect leaks for a predetermined period of time.</li> </ul>	—	B
C2253	Color PC motor's failure to turn	<ul style="list-style-type: none"> <li>The motor lock signal remains HIGH for a predetermined continuous period of time while the motor is turning.</li> </ul>	—	B
C2254	Color PC motor's turning at abnormal timing	<ul style="list-style-type: none"> <li>The motor lock signal remains LOW for a predetermined continuous period of time while the motor remains stationary.</li> </ul>	—	B
C225D	Color dev. unit engagement/disengagement failure	<ul style="list-style-type: none"> <li>The gears remain disengaged after the lapse of a predetermined period of time after the engagement operation is started by the color dev. unit engaged motor.</li> <li>The gears remain engaged after the lapse of a predetermined period of time after the disengagement operation is started by the color dev. unit engaged motor.</li> </ul>	—	B
C2351	K toner suction fan motor's failure to turn	<ul style="list-style-type: none"> <li>The motor lock signal remains HIGH for a predetermined continuous period of time while the motor is turning.</li> </ul>	—	B
C2451	Release new transfer belt unit	<ul style="list-style-type: none"> <li>A new installation is not detected when a new transfer cleaner unit (image transfer belt unit) is installed.</li> </ul>	—	B

Code	Item	Detection timing	Trouble isolation compliant unit	Rank
C2551	Abnormally low toner density detected cyan TCR sensor	<ul style="list-style-type: none"> <li>TC ratio in the developing machine, which is determined by toner replenishing amount control mechanism, is 4 % or less for a given number of times consecutively.</li> </ul>	—	B
C2552	Abnormally high toner density detected cyan TCR sensor	<ul style="list-style-type: none"> <li>TC ratio in the developing machine, which is determined by Toner replenishing amount control mechanism, is 11 % or more for a given number of times consecutively.</li> </ul>	—	B
C2553	Abnormally low toner density detected magenta TCR sensor	<ul style="list-style-type: none"> <li>TC ratio in the developing machine, which is determined by toner replenishing amount control mechanism, is 4 % or less for a given number of times consecutively.</li> </ul>	—	B
C2554	Abnormally high toner density detected magenta TCR sensor	<ul style="list-style-type: none"> <li>TC ratio in the developing machine, which is determined by toner replenishing amount control mechanism, is 11 % or more for a given number of times consecutively.</li> <li>When the connector of the TCR sensor is disconnected.</li> </ul>	—	B
C2555	Abnormally low toner density detected yellow TCR sensor	<ul style="list-style-type: none"> <li>TC ratio in the developing machine, which is determined by toner replenishing amount control mechanism, is 4 % or less for a given number of times consecutively.</li> <li>When the connector of the TCR sensor is disconnected.</li> </ul>	—	B
C2556	Abnormally high toner density detected yellow TCR sensor	<ul style="list-style-type: none"> <li>TC ratio in the developing machine, which is determined by toner replenishing amount control mechanism, is 11 % or more for a given number of times consecutively.</li> <li>When the connector of the TCR sensor is disconnected.</li> </ul>	—	B
C2557	Abnormally low toner density detected black TCR sensor	<ul style="list-style-type: none"> <li>TC ratio in the developing machine, which is determined by toner replenishing amount control mechanism, is 4 % or less for a given number of times consecutively.</li> </ul>	—	B
C2558	Abnormally high toner density detected black TCR sensor	<ul style="list-style-type: none"> <li>TC ratio in the developing machine, which is determined by toner replenishing amount control mechanism, is 11 % or more for a given number of times consecutively.</li> <li>When the connector of the TCR sensor is disconnected.</li> </ul>	—	B
C2559	Cyan TCR sensor adjustment failure	<ul style="list-style-type: none"> <li>TCR sensor automatic adjustment does not function properly, failing to adjust to an appropriate value.</li> </ul>	—	B
C255A	Magenta TCR sensor adjustment failure		—	B
C255B	Yellow TCR sensor adjustment failure		—	B
C255C	Black TCR sensor adjustment failure		—	B

Code	Item	Detection timing	Trouble isolation compliant unit	Rank
C2650	Main backup media access error	<ul style="list-style-type: none"> <li>The re-written data, which has been read out, checked and founded as error, is read out again and found as error.</li> <li>The error was found when reading out the counter value.</li> <li>The machine detects that the service EEPROM board is not loaded in position.</li> </ul>	—	—
C2651	EEPROM access error (IU C)	<ul style="list-style-type: none"> <li>An error was found when reading or writing data.</li> <li>The error was found when reading out the counter value.</li> </ul>	—	C
C2652	EEPROM access error (IU M)		—	C
C2653	EEPROM access error (IU Y)		—	C
C2654	EEPROM access error (IU K)		—	C
C2A01	EEPROM access error (TC C)	<ul style="list-style-type: none"> <li>An error was found when reading or writing data.</li> <li>The error was found when reading out the counter value.</li> </ul>	—	C
C2A02	EEPROM access error (TC M)		—	C
C2A03	EEPROM access error (TC Y)		—	C
C2A04	EEPROM access error (TC K)		—	C
C3101	Fusing roller separation failure	<ul style="list-style-type: none"> <li>With the fusing roller being retracted, the pulse of the fusing roller retraction sensor does not change even after the specified period of time has passed after the fusing retraction motor started rotating.</li> <li>With the fusing roller being pressed, the pulse of the roller retraction sensor does not change even after the specified period of time has passed after the fusing retraction motor started rotating.</li> <li>During a pressure operation of the fusing roller, the fusing roller is not at the pressed position even after the roller retraction sensor counts the specified number of pulses after the fusing retraction motor starts rotating.</li> </ul>	—	B
C3201	Fusing motor failure to turn	<ul style="list-style-type: none"> <li>The motor lock signal remains HIGH for a predetermined continuous period of time while the motor remains stationary.</li> </ul>	—	B
C3202	Fusing motor turning at abnormal timing	<ul style="list-style-type: none"> <li>The motor lock signal remains LOW for a predetermined continuous period of time while the motor remains stationary.</li> </ul>	—	B
C3301	Fusing cooling fan motor/1 failure to turn	<ul style="list-style-type: none"> <li>The fan motor lock signal remains HIGH for a predetermined continuous period of time while the motor remains stationary.</li> </ul>	—	B



Code	Item	Detection timing	Trouble isolation compliant unit	Rank
C3302	Fusing cooling fan motor/ 2,3 failure to turn	<ul style="list-style-type: none"> <li>The fan motor lock signal remains HIGH for a predetermined continuous period of time while the motor remains stationary.</li> </ul>	—	B
C3421	Fusing heaters trouble (heating side)	<ul style="list-style-type: none"> <li>The temperature detected by the heating roller thermistor/C does not reach a predetermined level after the lapse of a predetermined period of time after the heating roller fusing heater lamp lights up.</li> <li>The difference between the maximum and minimum temperatures detected by the heating roller thermistor/C within a predetermined period of time after the start of a warm-up cycle is below or above a predetermined value.</li> <li>The temperature detected after a pressure level correction remains under a predetermined level even after the lapse of a predetermined period of time after the start of the temperature detection.</li> <li>During a warm-up, a zero cross signal cannot be detected after the lapse of a predetermined period of time after the fusing heater is turned ON or OFF.</li> </ul>	—	A
C3423	Fusing heaters trouble (pressurizing side)	<ul style="list-style-type: none"> <li>After warm-up operation starts, the fusing pressure roller thermistor does not detect a temperature as high as a predetermined one though a predetermined period of time has elapsed.</li> <li>The temperature of the pressure roller remains lower than a predetermined level even after the lapse of a predetermined period of time after a temperature correction.</li> </ul>	—	A
C3461	Release new fusing unit	<ul style="list-style-type: none"> <li>A new installation is not detected when a new fusing Unit is installed.</li> </ul>	—	B
C3721	Fusing abnormally high temperature detection (heating side)	<ul style="list-style-type: none"> <li>The heating roller thermistor continues to detect a temperature higher than a predetermined one for a predetermined period of time.</li> <li>Hard protection signal L is detected continuously over a predetermined period of time.</li> </ul>	—	A
C3723	Fusing abnormally high temperature detection (pressurizing side)	<ul style="list-style-type: none"> <li>The temperature of the pressure roller continues to be higher than a predetermined level for a predetermined period of time after a temperature correction.</li> </ul>	—	A

Code	Item	Detection timing	Trouble isolation compliant unit	Rank
C3821	Fusing abnormally low temperature detection (heating side)	<ul style="list-style-type: none"> <li>The heating roller thermistor continues to detect a temperature lower than a predetermined one for a predetermined period of time.</li> <li>In the states other than a warm-up operation, a zero cross signal cannot be detected after the lapse of a predetermined period of time after the fusing heater is turned ON or OFF.</li> <li>The power supply frequency cannot be detected.</li> </ul>	—	A
C3823	Fusing abnormally low temperature detection (pressurizing side)	<ul style="list-style-type: none"> <li>The temperature of the pressure roller continues to be lower than a predetermined level for a predetermined period of time after a temperature correction.</li> </ul>	—	A
C4151	Polygon motor rotation trouble (C)	<ul style="list-style-type: none"> <li>The polygon motor fails to turn stably even after the lapse of a given period of time after activating the polygon motor.</li> <li>Motor lock signal detects HIGH for a given period time consecutively during the polygon motor is rotating.</li> </ul>	—	B
C4152	Polygon motor rotation trouble (M)		—	B
C4153	Polygon motor rotation trouble (Y)		—	B
C4154	Polygon motor rotation trouble (K)		—	B
C4551	Laser malfunction (C)	<ul style="list-style-type: none"> <li>SOS signal is not detected even after the lapse of a given period of time after starting the laser output.</li> <li>SOS signal is not detected for a given period of time during printing or image stabilization adjustment.</li> </ul>	—	B
C4552	Laser malfunction (M)		—	B
C4553	Laser malfunction (Y)		—	B
C4554	Laser malfunction (K)		—	B
C5102	Transport motor's failure to turn	<ul style="list-style-type: none"> <li>The motor lock signal remains HIGH for a predetermined continuous period of time while the motor remains stationary.</li> </ul>	—	B
C5103	Transport motor's turning at abnormal timing	<ul style="list-style-type: none"> <li>The motor lock signal remains LOW for a predetermined continuous period of time while the motor remains stationary.</li> </ul>	—	B
C5351	Power supply cooling fan motor/1's failure to turn	<ul style="list-style-type: none"> <li>The fan lock signal remains HIGH for a predetermined continuous period of time while the motor remains stationary.</li> </ul>	—	B
C5353	Cooling fan motor/2's failure to turn	<ul style="list-style-type: none"> <li>The fan lock signal remains HIGH for a predetermined continuous period of time while the motor remains stationary.</li> </ul>	—	B
C5354	Exhaust fan motor's failure to turn	<ul style="list-style-type: none"> <li>The fan lock signal remains HIGH for a predetermined continuous period of time while the motor remains stationary.</li> </ul>	—	B
C5357	Cooling fan motor/1's failure to turn	<ul style="list-style-type: none"> <li>The fan lock signal remains HIGH for a predetermined continuous period of time while the motor remains stationary.</li> </ul>	—	B
 C5370	MFP board cooling fan motor's failure to turn	<ul style="list-style-type: none"> <li>The fan lock signal remains HIGH for a predetermined continuous period of time while the motor remains stationary.</li> </ul>	—	B



Code	Item	Detection timing	Trouble isolation compliant unit	Rank
C5371	MFP board CPU cooling fan motor's failure to turn	<ul style="list-style-type: none"> <li>The fan lock signal remains HIGH for a pre-determined continuous period of time while the motor remains stationary.</li> </ul>	—	B
C6102	Drive system home sensor malfunction	<ul style="list-style-type: none"> <li>The scanner home sensor is unable to detect the scanner located at its home position.</li> <li>The scanner home sensor is unable to detect a scanner even when the scanner motor has been driven to move the scanner over the maximum travelling distance.</li> <li>The scanner home sensor detects the scanner when the scanner has moved the maximum travelling distance from the position, at which it blocks the scanner home sensor.</li> </ul>	Scanner	B
C6103	Slider over running	<ul style="list-style-type: none"> <li>The scanner home sensor detects the scanner at its home position during a period of time that begins with the time when a pre-scan command and a scan preparation command are executed and ends when a home return command is executed.</li> </ul>		B
C6301	Optical cooling fan motor's failure to turn	<ul style="list-style-type: none"> <li>The fan lock signal remains HIGH for a pre-determined continuous period of time while the motor remains stationary.</li> </ul>		B
C6704	Image input time out	<ul style="list-style-type: none"> <li>Image data is not input from the image processing board (IPB) to the printer control board (PRCB).</li> </ul>		C
C6751	CCD clamp/gain adjustment failure	<ul style="list-style-type: none"> <li>The adjustment value is 0 or 255 during a CCD clamp adjustment.</li> <li>The peak value of the output data is 64 or less during a CCD gain adjustment.</li> </ul>		B
C6F01	Scanner sequence trouble 1	<ul style="list-style-type: none"> <li>The original transport interval becomes shorter than the designed value due to an original transport control error in original reading in ADF.</li> </ul>		C
C6F02	Reserved			
C6F03	Reserved			
C6F04	Reserved			
C6F05	Reserved			
C6F06	Reserved			
C6F07	Reserved			
C6F08	Reserved			
C6F09	Reserved			
C6F10	Reserved			
C6FDC	Reserved			

Code	Item	Detection timing	Trouble isolation compliant unit	Rank
C8101	Before reading pressure welding alienation mechanism	See P.60 of the DF-611 service manual.	—	B
C8102	Turn around pressure welding alienation trouble		—	B
C8103	Lift up mechanism trouble		—	B
C8104	Glass movement trouble		—	B
C8105	Undetectable			
C8302	Read cooling fan trouble	See P.60 of the DF-611 service manual.	—	B
C9401	Exposure turning on the lamp trouble detection	<ul style="list-style-type: none"> <li>The output from the CCD sensor is a predetermined value or less during CCD sensor gain adjustment.</li> </ul>	Scanner	A
C9402	Exposure turning on the lamp abnormally detection	<ul style="list-style-type: none"> <li>The average output value of the CCD sensor with the scanner at its standby position is a predetermined value or more at the end of a scan job.</li> </ul>	Scanner	A
CA051	Standard controller configuration failure	<ul style="list-style-type: none"> <li>The controller of the printer control board (PRCB) is faulty.</li> </ul>	—	C
CA052	Controller hardware error	<ul style="list-style-type: none"> <li>A controller hardware error is detected in the network I/F.</li> </ul>	—	C
CA053	Controller start failure	<ul style="list-style-type: none"> <li>A controller start failure is detected in the controller interface.</li> </ul>	—	C
CB001	FAX board error 1	See the FK-502 Service Manual.	—	C
CB002	FAX board error 2		—	C
CB003	FAX board error 3		—	C
CB051	FAX board mount failure line 1		—	C
CB052	FAX board mount failure line 2		—	C
CB110	FAX driver error: Instance generation error or observer registration error		—	C
CB111	FAX driver error: Configuration space initialization NG		—	C
CB112	FAX driver error: Semaphore acquisition, release error		—	C
CB113	FAX driver error: Sequence error among main body tasks		—	C
CB114	FAX driver error: Message queue control error		—	C
CB115	FAX driver error: Main body - sequence error among FAX boards		—	C

bizhub C353/C253/C203

Troubleshooting

Code	Item	Detection timing	Trouble isolation compliant unit	Rank
CB116	FAX driver error: FAX board nonresponse (Nonresponse after initialization)	See the FK-502 Service Manual.	—	C
CB117	FAX driver error: ACK waiting timeout error		—	C
CB118	FAX driver error: Receiving undefined frame		—	C
CB119	FAX driver error: DMA transfer error		—	C
CB120	JC soft error		—	C
CB122	Device error (GA LOCAL SRAM)		—	C
CB123	Device error (DRAM)		—	C
CB125	Device error (GA)		—	C
CB126	Timeout error due to nonresponse from DC during suspension process		—	C
CB127	Timeout error due to nonresponse from CC during suspension process		—	C
CB128	Timeout error due to nonresponse from LINE during suspension process		—	C
CB129	Timeout error due to nonresponse from file system/file driver during suspension process		—	C
CB130	MIF driver error: Driver soft error		—	C
CB131	MIF driver error: Reception frame length error from main		—	C
CB132	MIF driver error: Reception frame header error from main		—	C
CB133	MIF driver error: 232C i/f sequence error		—	C
CB134	MIF driver error: DPRAM i/f sequence error		—	C
CB135	MIF driver error: DPRAM CTL/STL register error		—	C
CB136	MIF driver error: AKC waiting timeout		—	C
CB137	MIF driver error: DPRAM RESET reception		—	C
CB140	MSG I/F Error with JC	—	C	

Code	Item	Detection timing	Trouble isolation compliant unit	Rank
CB141	I/F error with main: I/F error with driver	See the FK-502 Service Manual.	—	C
CB142	I/F error with main: Undefined command reception		—	C
CB143	I/F error with main: Command frame length error		—	C
CB144	I/F error with main: Command parameter length error		—	C
CB145	I/F error with main: Undefined parameter		—	C
CB146	I/F error with main: Command/response sequence error		—	C
CB150	Line control: External class instance acquisition error		—	C
CB151	Line control: Job start error (Starting job parameter error/child job generation error)		—	C
CB152	Line control: Doc access error (Report buf access error)		—	C
CB153	Line control: Response wait timeout from external task		—	C
CB154	Line control: Internal queue control error (create/enque/deque)		—	C
CB160	1 destination control: Instance generation error		—	C
CB161	1 destination control: Timeout error		—	C
CB162	1 destination control: Interface error		—	C
CB163	1 destination control: Message queue control error		—	C
CB164	1 destination control: Semaphore acquisition release error		—	C
CB165	1 destination control: Observer registration error	—	C	
CB166	1 destination control: Reception resource check error	—	C	

Code	Item	Detection timing	Trouble isolation compliant unit	Rank
CB167	1 destination control: Deployment error of sending image information	See the FK-502 Service Manual.	—	C
CB168	1 destination control: Serialization error of receiving image		—	C
CB169	1 destination control: Access error to quick memory data		—	C
CB170	Page control: Internal queue control error (create/enque/deque)		—	C
CB171	Page control: Instance generation error		—	C
CB172	Page control: Timeout error		—	C
CB173	Page control: Interface error		—	C
CB174	Page control: Semaphore acquisition release error		—	C
CB175	Page control: Observer registration error		—	C
CB176	Page control: Unable to check TTI domain		—	C
CB177	Page control: Error return from TTI rasterizer		—	C
CB178	Page control: Receiving job generation error		—	C
CB185	Page control: Receiving data size logic error (Receiving data are not multiples of dotline)		—	C
CB186	Page control: Image buf acquisition (alloc) error		—	C
CB187	Page control: Error return from compressor	—	C	
CB188	Page control: BandBuf control error (newInstance/get/free)	—	C	
CC001	Vendor connection failure	<ul style="list-style-type: none"> <li>It is detected that communications with the vendor are interrupted for a given period of time or more with "Installed" selected for the setting of vendor installation.</li> </ul>	—	C
CC151	ROM contents error upon startup (MSC)	<ul style="list-style-type: none"> <li>A fault is detected in a sequence of ROM contents check of the MSC (PRCB) during starting</li> </ul>	—	C
CC152	ROM contents error upon startup (scanner)	<ul style="list-style-type: none"> <li>A fault is detected in a sequence of ROM contents check of the IPB during starting.</li> </ul>	—	C

Code	Item	Detection timing	Trouble isolation compliant unit	Rank
CC153	ROM contents error upon startup (PRT)	• A fault is detected in a sequence of ROM contents check of the mechanical control board (MFPB) during starting.	—	C
CC155	Finisher ROM error	See P.79 of the FS-519/PK-515/OT-602 service manual. See P.22 of the JS-505 service manual.	—	C
CC156	ADF ROM error	See P.60 of the DF-611 service manual.	—	C
CC163	ROM contents error (PRT)	• The wrong model of firmware is detected in the engine during the initial connection to the engine is being checked.	—	C
CC164	ROM contents error (MSC)	• The wrong model of firmware is detected in the MFP board when the main power switch is turned ON.	—	C
CC165	ROM contents error (ADF)	See P.60 of the DF-611 service manual.	—	C
CC170	Dynamic link error during starting (AP0)	• A dynamic link error occurs in the program on the MFP board due to an insufficient memory space available, a ROM fault, or other reason when the main power switch is turned ON.	—	C
CC171	Dynamic link error during starting (AP1)		—	C
CC172	Dynamic link error during starting (AP2)		—	C
CC173	Dynamic link error during starting (AP3)		—	C
CC174	Dynamic link error during starting (AP4)		—	C
△ CC180	Dynamic link error during starting (LDR)		—	C
△ CC181	Dynamic link error during starting (IBR)		—	C
△ CC182	Dynamic link error during starting (IID)		—	C
△ CC183	Dynamic link error during starting (IPF)		—	C
△ CC184	Dynamic link error during starting (IMY)	—	C	
CD002	JOB RAM save error	• The error in save of JOB data to the memory/ hard disk and its read error are detected.	—	C
CD004	Hard disk access error	• Unable to communicate between the hard disk and printer control board (PRCB).	—	C





Code	Item	Detection timing	Trouble isolation compliant unit	Rank
CD005	Hard disk error 1	<ul style="list-style-type: none"> <li>Hard disk is faulty.</li> </ul>	—	C
CD006	Hard disk error 2		—	C
CD007	Hard disk error 3		—	C
CD008	Hard disk error 4		—	C
CD009	Hard disk error 5		—	C
CD00A	Hard disk error 6		—	C
CD00B	Hard disk error 7		—	C
CD00C	Hard disk error 8		—	C
CD00D	Hard disk error 9		—	C
CD00E	Hard disk error A		—	C
CD00F	Hard disk data transfer error		<ul style="list-style-type: none"> <li>Data transfer from the hard disk is faulty.</li> </ul>	—
CD010	Hard disk unformat	<ul style="list-style-type: none"> <li>Unformatted hard disk is connected.</li> </ul>	—	C
CD011	Hard disk out of specifications mounted	<ul style="list-style-type: none"> <li>A hard disk that falls outside the specifications is connected.</li> </ul>	—	C
CD020	Hard disk verify error	<ul style="list-style-type: none"> <li>The data abnormality is detected by the HDD verify check.</li> </ul>	—	C
CD030	Hard disk management information reading error	<ul style="list-style-type: none"> <li>The machine fails to read administrative information data saved in the hard disk.</li> </ul>	—	C
CD201	File memory mounting error	<ul style="list-style-type: none"> <li>The file memory is not mounted.</li> <li>The file has any abnormality.</li> </ul>	—	C
CD202	Memory capacity discrepancy	<ul style="list-style-type: none"> <li>File memory capacity on the printer control board (PRCB) is not enough.</li> <li>File memory capacity necessary for duplex printing is not enough during duplex unit mounting.</li> </ul>	—	C
CD203	Memory capacity discrepancy 2	<ul style="list-style-type: none"> <li>File memory capacity on the printer control board (PRCB) is not enough.</li> </ul>	—	C
CD211	PCI-SDRAM DMA operation failure	<ul style="list-style-type: none"> <li>Hardware related to the transfer of memory image of the Printer control board (PRCB) fails to respond.</li> </ul>	—	C
CD212	Compression/extraction timeout detection	<ul style="list-style-type: none"> <li>Hardware related to the BTC compression function of the Printer control board (PRCB) fails to respond.</li> </ul>	—	C
CD231	No Fax memory at FAX board mounting	<ul style="list-style-type: none"> <li>The DIMM for FAX is not mounted during the FAX board is mounting.</li> <li>The FAX board is not mounted when the FAX board mounting is set ON at Service Mode.</li> </ul>	—	C
CD241	Encryption board setting error	<ul style="list-style-type: none"> <li>Initialization error of the encrypted ASIC is detected during the machine is starting.</li> </ul>	—	C
CD242	Encryption board mounting error	<ul style="list-style-type: none"> <li>The faulty of the installation of encrypted ASIC is detected during the machine is starting.</li> </ul>	—	C
CD251	No JPEG board mounting at JPEG board mount setting	<ul style="list-style-type: none"> <li>JPEG board (scan accelerator kit) is not mounted when the JPEG board mounting is set ON at Service Mode.</li> </ul>	—	C



Code	Item	Detection timing	Trouble isolation compliant unit	Rank
CD261	USB host board failure	<ul style="list-style-type: none"> <li>When a failure is detected in USB host board included in the local interface kit.</li> <li>Non-standard USB device is connected.</li> </ul>	—	C
CD271	i-Option activated and additional memory not installed	<ul style="list-style-type: none"> <li>While the i-Option is activated, the additional memory included in UK-201 is not installed.</li> </ul>	—	C
CD3##	NVRAM data error	<ul style="list-style-type: none"> <li>Abnormality is detected by the abnormal check of each NVRAM data.</li> </ul>	—	—
CD370	NVRAM data multiple errors	<ul style="list-style-type: none"> <li>Multiple errors (over 5) are detected by the abnormal check of each NVRAM data.</li> </ul>	—	—
CDC##	Trouble related to security	<ul style="list-style-type: none"> <li>Contact the responsible people of KMBT before taking some countermeasures.</li> </ul>	—	—
CD401	NACK command incorrect	<ul style="list-style-type: none"> <li>When abnormality is found in the communication of controller.</li> </ul>	—	C
CD402	ACK command incorrect		—	C
CD403	Checksum error		—	C
CD404	Receiving packet incorrect		—	C
CD405	Receiving packet analysis error		—	C
CD406	ACK receiving timeout		—	C
CD407	Retransmission timeout		—	C
CE001	Abnormal message queue		<ul style="list-style-type: none"> <li>Printer control board (PRCB) is faulty.</li> </ul>	—
CE002	Message and method parameter failure	—		C
CE003	Task error	—		C
CE004	Event error	—		C
CE005	Memory access error	—		C
CE006	Header access error	—		C
CE007	DIMM initialize error	—		C
CEEE1	MSC undefined malfunction occurring	<ul style="list-style-type: none"> <li>An undefined malfunction occurs in the MSC of the printer control board (PRCB).</li> </ul>	—	C
CEEE2	Scanner section undefined malfunction	<ul style="list-style-type: none"> <li>An undefined malfunction occurs in the scanner section.</li> </ul>	—	C
CEEE3	Engine section undefined malfunction	<ul style="list-style-type: none"> <li>An undefined malfunction occurs in the engine section (MFPB, etc.).</li> </ul>	—	C

bizhub\_C353/C253/C203

Troubleshooting

- The machine displays an abort code (CF###) on the control panel as it becomes unable to process tasks properly through its software control.
- When the system program is aborted, check the electrical component, unit, option, and connection relating to the specific type of the abort condition.

Code	Item	Relevant electrical components, units, and options	Rank
CF001	CT_singleList table abnormal	• MFP board (MFPB)	C
CF002	CT_doubleList table abnormal		C
CF003	CT_doubleList table abnormal		C
CF004	CT_queue full abnormal		C
CF011	Array link abnormal		C
CF012	FAT link abnormal		C
CF013	File size abnormal		C
CF021	setDelayMessage Table OverFlow		C
CF022	procSetBootParamTcpipAddress() injustice		C
CF023	MsgQue OverFlow		C
CF031	getJobPageToIPE() page number injustice		C
CF032	getJobHDDPageToIPE() page number injustice		C
CF033	setDivTbl() limitation over		C
CF034	HDDQUEUE Over Flow		C
CF041	getAPPPtrFromAPPID() abnormal		C
CF042	getAPPIndexFromAPPID() abnormal	C	
CF051	CC_InputPageEntry:operator[] page injustice	An exceptional instance occurred due to the unexpected parameter in the system F/W.	C
CF061	IdeCommand_Set() status abnormal		C
CF062	IdeCommand_Set() parameter abnormal		C
CF091	PCI ASIC1 ERROR	ASIC1 error	C
CF092	PCI ASIC2 ERROR	ASIC2 error	C
CF093	PCI ASIC4 ERROR	ASIC3 error	C
CF101	SCAN TIME OUT	Image transfer malfunctions	C
CF111	Compress TIME OUT	Compression malfunctions	C
CF112	Compress table OverFlow		C
CF113	Compress table check		C
CF121	Expand TIME OUT		C
CF122	Expand table OverFlow		C
CF123	Expand expandLine abnormal		C

Code	Item	Relevant electrical components, units, and options	Rank			
CF131	Print TIME OUT	• MFP board (MFPB)	C			
CF201	startIRReadAnd Compress()Sequence		An exceptional instance occurred due to the unexpected parameter in the system F/W.	C		
CF202	startWorkSave()Sequence abnormal			C		
CF203	convAPItoJCPParameter()page abnormal			C		
CF204	calcCompressorUse()CmpExpID Abnormal			C		
CF211	setParameterBandColorPlane() Table OverFlow			C		
CF212	convAPItoJCPParameter()page abnormal			C		
CF213	calcExpandUse() CmpExpID abnormal			C		
CF221	startPrintOutput outputsize zero			C		
CF222	Next request comes during processing of startPrintOutput ()			C		
CF223	Next request comes during processing of startWorkLoad-Output ()			C		
CF300	IR Bus Check Timeout			Image transfer error on IR input bus	C	
CF411	Parity error				Communication error (between IR-systems)	C
CF421	Overrun error					C
CF431	Parity error + Overrun error	C				
CF441	Framing error	C				
CF451	Parity error + Framing error	C				
CF461	Overrun error + Framing error	C				
CF471	Parity error + Overrun error + Framing error	C				
CF412	Parity error	C				
CF422	Overrun error	C				
CF432	Parity error + Overrun error	C				
CF442	Framing error	C				
CF452	Parity error + Framing error	C				
CF462	Overrun error + Framing error	C				
CF472	Parity error + Overrun error + Framing error	C				
CF510	Parity error	C				

bizhub\_C353/C253/C203

Troubleshooting

Code	Item	Relevant electrical components, units, and options	Rank	
CF520	Framing error	• MFP board (MFPB)	C	
CF530	Parity error + Framing error		C	
CF540	Overrun error		C	
CF550	Parity error + Overrun error		C	
CF560	Overrun error + Framing error		C	
CF570	Parity error + Overrun error + Framing error		C	
CF580	Frame distortion of ADF		C	
CF600	Report receiving of print start that is out of sequence		• MFP board (MFPB)/ Engine	C
CF601	Report receiving of paper feeding that is out of sequence	C		
CF604	Outside IF/Command queue	• MFP board (MFPB)	C	
CF614	"Output sequence" queue		C	
CF624	Panel LCD date queue		C	
CF704	Common data "Delete-waiting HDD accumulated job ID" queue		C	
CF714	IRC/Command queue		C	
CF724	Engine/Command queue		• MFP board (MFPB)/ Engine	C
CF734	Panel/Command queue		• MFP board (MFPB)/ Control Panel	C
CF744	File memory transfer start-waiting command queue		• MFP board (MFPB)	C
CF754	File memory compression requesting command queue	C		
CF764	Panel instruction delete job queue	C		
CF774	Warning delete job queue	C		
CF784	Application instruction delete job queue	C		
CF794	Output page information for duplex back side queue	C		
CF7A4	Paper feed completion output page information queue	C		
CF7B4	Exposure compaction output page information queue	C		
CF7C4	Pre-discharge completion output page information queue	C		
CF7D4	Touch panel coordinate data queue	C		
CF7E4	Direct key data queue	C		
CF7F4	Scan sequence queue	C		
CF802	SIO sending port...ENG	• MFP board (MFPB)/ Engine	C	

Code	Item	Relevant electrical components, units, and options	Rank	
CF806	SIO sending port...IRC	• MFP board (MFPB)	C	
CF807	SIO sending port...ADF		C	
CF812	SIO sending port...Fiery	• External controller I/F board	C	
CF815	SIO sending port...PIC/PIC terminal	• MFP board (MFPB)	C	
CF8ED	SIO sending port...EPNet		C	
CF902	SIO receiving port...ENG	• MFP board (MFPB)/ Engine	C	
CF906	SIO receiving port...IRC	• MFP board (MFPB)	C	
CF912	SIO receiving port...Fiery	• External controller I/F board	C	
CF915	SIO receiving port...PIC/PIC terminal	• MFP board (MFPB)	C	
CF9ED	SIO receiving port...EPNet		C	
CFA01	getOneImgTransInfoFromTh() No applied thread		An exceptional instance occurred due to the unexpected parameter in the system F/W.	C
CFA02	chkEnableAllocExec() default error			C
CFA03	setTransBandAndRepeatNum() error			C
CFA04	Application ID error			C
CFA05	Thread selection image processing mode error			C
CFA06	getOneImgIndexNumFromTh() No applied thread		An exceptional instance occurred due to the unexpected parameter in the system F/W.	C
CFA07	setBufBandFromOut() No applied thread			C
CFA08	chkStartOutput() No applied thread			C
CFA09	rptReleaseMemResultACS() No applied thread			C
CFA10	rptEndBandTrans() No applied thread			C
CFA11	cancelTransExec() No applied thread			C
CFA12	CC_ImgTransInfo:allocTransIndex			C
CFA13	CC_MultiThreadProfile:rptBuf2 MemClrEnd	C		
CFA14	Thread software error	• Whole electrical components, units, and options	C	
△ CFA50	IGC control error	DB error	• MFP board (MFPB)	
△ CFA51		IGC internal error		C

Code	Item	Relevant electrical components, units, and options	Rank
CFB00	ASIC117 first sheet DMA00	• MFP board (MFPB)	C
CFB01	ASIC117 first sheet DMA01		C
CFB02	ASIC117 first sheet DMA02		C
CFB03	ASIC117 first sheet DMA03		C
CFB04	ASIC117 first sheet DMA04		C
CFB05	ASIC117 first sheet DMA05		C
CFB06	ASIC117 first sheet DMA06		C
CFB07	ASIC117 first sheet DMA07		C
CFB08	ASIC117 first sheet DMA08		C
CFB09	ASIC117 first sheet DMA09		C
CFB0A	ASIC117 first sheet DMA10		C
CFB10	ASIC117 first sheet DMA16		C
CFB11	ASIC117 first sheet DMA17		C
CFB12	ASIC117 first sheet DMA18		C
CFB13	ASIC117 first sheet DMA19		C
CFB14	ASIC117 first sheet DMA20		C
CFB15	ASIC117 first sheet DMA21		C
CFB16	ASIC117 first sheet DMA22		C
CFB17	ASIC117 first sheet DMA23		C
CFB18	ASIC117 first sheet DMA24	C	
CFB19	ASIC117 first sheet DMA25	C	
CFB1A	ASIC117 first sheet DMA26	C	
CFB1B	ASIC117 first sheet DMA27	C	
CFB1C	ASIC117 first sheet DMA28	C	
CFB1D	ASIC117 first sheet DMA29	C	
CFB1E	ASIC117 first sheet DMA30	C	
CFB20	ASIC117 second sheet DMA00	• External controller I/F board	C
CFB21	ASIC117 second sheet DMA01		C
CFB22	ASIC117 second sheet DMA02		C
CFB23	ASIC117 second sheet DMA03		C
CFB24	ASIC117 second sheet DMA04		C
CFB25	ASIC117 second sheet DMA05		C
CFB26	ASIC117 second sheet DMA06		C
CFB27	ASIC117 second sheet DMA07		C
CFB28	ASIC117 second sheet DMA08		C
CFB29	ASIC117 second sheet DMA09		C
CFB2A	ASIC117 second sheet DMA10		C
CFB30	ASIC117 second sheet DMA16		C
CFB31	ASIC117 second sheet DMA17		C
CFB32	ASIC117 second sheet DMA18	C	

Code	Item	Relevant electrical components, units, and options	Rank
CFB33	ASIC117 second sheet DMA19	• External controller I/F board	C
CFB34	ASIC117 second sheet DMA20		C
CFB35	ASIC117 second sheet DMA21		C
CFB36	ASIC117 second sheet DMA22		C
CFB37	ASIC117 second sheet DMA23		C
CFB38	ASIC117 second sheet DMA24		C
CFB39	ASIC117 second sheet DMA25		C
CFB3A	ASIC117 second sheet DMA26		C
CFB3B	ASIC117 second sheet DMA27		C
CFB3C	ASIC117 second sheet DMA28		C
CFB3D	ASIC117 second sheet DMA29		C
CFB3E	ASIC117 second sheet DMA30		C
CFB40	ASIC7 DMA A		• JPEG board
CFB41	ASIC7 DMA C	C	
CFB42	ASIC7 DMA D	C	
CFB60	ASIC117 first sheet interruption	• MFP board (MFPB)	C
CFB61	ASIC117 second sheet interruption	• External controller I/F board	C
CFB62	ASIC7 interruption	• JPEG board	C
CFB70	ASIC117 first sheet common register setting	• MFP board (MFPB)	C
CFB71	ASIC117 second sheet common register setting	• External controller I/F board	C
CFB72	ASIC7 common register setting	• JPEG board	C
CFB80	ASIC117 first sheet PCIBridgeDMA	• MFP board (MFPB)	C
CFB81	ASIC117 second sheet PCIBridgeDMA	• External controller I/F board	C
CFB82	ASIC7 PCIBridgeDMA	• JPEG board	C
CFB90	ASIC117 first sheet BTC compander/expander	• MFP board (MFPB)	C
CFB91	ASIC117 second sheet BTC compander/expander	• External controller I/F board	C
CFB92	ASIC7 BTC compander/expander	• JPEG board	C
CFC00	ASIC117 first sheet DMA00 error interruption	• MFP board (MFPB)	C
CFC01	ASIC117 first sheet DMA01 error interruption		C
CFC02	ASIC117 first sheet DMA02 error interruption		C
CFC03	ASIC117 first sheet DMA03 error interruption		C
CFC04	ASIC117 first sheet DMA04 error interruption		C
CFC05	ASIC117 first sheet DMA05 error interruption		C
CFC06	ASIC117 first sheet DMA06 error interruption		C
CFC07	ASIC117 first sheet DMA07 error interruption		C
CFC08	ASIC117 first sheet DMA08 error interruption		C
CFC09	ASIC117 first sheet DMA09 error interruption		C
CFC0A	ASIC117 first sheet DMA10 error interruption		C

bizhub\_C353/C253/C203

Troubleshooting



Code	Item	Relevant electrical components, units, and options	Rank
CFC10	ASIC117 first sheet DMA16 error interruption	• MFP board (MFPB)	C
CFC11	ASIC117 first sheet DMA17 error interruption		C
CFC12	ASIC117 first sheet DMA18 error interruption		C
CFC13	ASIC117 first sheet DMA19 error interruption		C
CFC14	ASIC117 first sheet DMA20 error interruption		C
CFC15	ASIC117 first sheet DMA21 error interruption		C
CFC16	ASIC117 first sheet DMA22 error interruption		C
CFC17	ASIC117 first sheet DMA23 error interruption		C
CFC18	ASIC117 first sheet DMA24 error interruption		C
CFC19	ASIC117 first sheet DMA25 error interruption		C
CFC1A	ASIC117 first sheet DMA26 error interruption		C
CFC1B	ASIC117 first sheet DMA27 error interruption		C
CFC1C	ASIC117 first sheet DMA28 error interruption		C
CFC1D	ASIC117 first sheet DMA29 error interruption		C
CFC1E	ASIC117 first sheet DMA30 error interruption		C
CFC20	ASIC117 first sheet SDC sleep illegal access error		C
CFC21	ASIC117 first sheet watchdog timer error interruption		C
CFC22	ASIC117 first sheet underrun at image output interface 1		C
CFC23	ASIC117 first sheet overflow at image input interface		C
CFC24	ASIC117 first sheet underrun at image output interface 1		C
CFC25	ASIC117 first sheet PCI master detects target abort		C
CFC26	ASIC117 first sheet master abort by PCI master		C
CFC27	ASIC117 first sheet PCI master detects illegal setting		C
CFC28	ASIC117 first sheet PCI master detects retry error		C
CFC29	ASIC117 first sheet PCI master detects split completion byte count malfunction		C
CFC2A	ASIC117 first sheet PCI master detects split completion error message		C
CFC2B	ASIC117 first sheet unknown marker detected at JBIG core		C
CFC2C	ASIC117 SC count overflow detected at JBIG core		C
CFC2D	ASIC117 first sheet master read data parity error		C
CFC2E	ASIC117 first sheet master write data parity error		C
CFC2F	ASIC117 first sheet system error		C
CFC30	ASIC117 first sheet sleep read data parity error		C
CFC31	ASIC117 first sheet sleep write data parity error	C	
CFC32	ASIC117 first sheet address parity error	C	
CFC50	ASIC117 second sheet DMA00 error interruption	• External controller I/F board	C
CFC51	ASIC117 second sheet DMA01 error interruption		C

Code	Item	Relevant electrical components, units, and options	Rank
CFC52	ASIC117 second sheet DMA02 error interruption	• External controller I/F board	C
CFC53	ASIC117 second sheet DMA03 error interruption		C
CFC54	ASIC117 second sheet DMA04 error interruption		C
CFC55	ASIC117 second sheet DMA05 error interruption		C
CFC56	ASIC117 second sheet DMA06 error interruption		C
CFC57	ASIC117 second sheet DMA07 error interruption		C
CFC58	ASIC117 second sheet DMA08 error interruption		C
CFC59	ASIC117 second sheet DMA09 error interruption		C
CFC5A	ASIC117 second sheet DMA10 error interruption		C
CFC60	ASIC117 second sheet DMA16 error interruption		C
CFC61	ASIC117 second sheet DMA17 error interruption		C
CFC62	ASIC117 second sheet DMA18 error interruption		C
CFC63	ASIC117 second sheet DMA19 error interruption		C
CFC64	ASIC117 second sheet DMA20 error interruption		C
CFC65	ASIC117 second sheet DMA21 error interruption		C
CFC66	ASIC117 second sheet DMA22 error interruption		C
CFC67	ASIC117 second sheet DMA23 error interruption		C
CFC68	ASIC117 second sheet DMA24 error interruption		C
CFC69	ASIC117 second sheet DMA25 error interruption		C
CFC6A	ASIC117 second sheet DMA26 error interruption		C
CFC6B	ASIC117 second sheet DMA27 error interruption	C	
CFC6C	ASIC117 second sheet DMA28 error interruption	C	
CFC6D	ASIC117 second sheet DMA29 error interruption	C	
CFC6E	ASIC117 second sheet DMA30 error interruption	C	
CFC70	ASIC117 second sheet SDC sleep illegal access error	C	
CFC71	ASIC117 second sheet watchdog timer error interruption	C	
CFC72	ASIC117 second sheet underrun at image output interface 1	C	
CFC73	ASIC117 second sheet overflow at image input interface	C	
CFC74	ASIC117 first sheet underrun at LCD output interface	• MFP board (MFPB)	C
CFC75	ASIC117 second sheet PCI master detects target abort	• External controller I/F board	C
CFC76	ASIC117 second sheet master abort by PCI master		C
CFC77	ASIC117 second sheet PCI master detects illegal setting		C
CFC78	ASIC117 second sheet PCI master detects retry error		C
CFC79	ASIC117 first sheet PCI master detects split completion byte count malfunction	• MFP board (MFPB)	C
CFC7A	ASIC117 first sheet PCI master detects split completion error message		C

bizhub C353/C253/C203

Troubleshooting

Code	Item	Relevant electrical components, units, and options	Rank
CFC7B	ASIC117 second unknown marker detected at JBIG core	• External controller I/F board	C
CFC7C	ASIC117 second SC count overflow detected at JBIG core		C
CFC7D	ASIC117 second sheet master read data parity error		C
CFC7E	ASIC117 second sheet master write data parity error		C
CFC7F	ASIC117 second sheet system error		C
CFC80	ASIC117 second sheet sleep read data parity error		C
CFC81	ASIC117 second sheet sleep write data parity error		C
CFC82	ASIC117 second sheet address parity error		C
CFCA0	ASIC7 DMA_A error interruption		• JPEG board
CFCA1	ASIC7 DMA_C error interruption	C	
CFCA2	ASIC7 DMA_D error interruption	C	
CFCA3	ASIC7 watchdog timer error	C	
CFCA4	ASIC7 PCI sleep error	C	
CFCA5	ASIC7 JPEG related interruption during internal processing at DMA_A	C	
CFCA6	ASIC7 JPEG related interruption during internal processing at DMA_A	C	
CFCA7	ASIC7 JPEG related interruption during internal processing at DMA_A	C	
CFCA8	ASIC7 JPEG related interruption during internal processing at DMA_A	C	
CFCA9	ASIC7 JPEG related interruption during internal processing at DMA_A	C	
CFCAA	ASIC7 JPEG related interruption during internal processing at DMA_A	C	
CFCAB	ASIC7 JPEG related interruption during internal processing at DMA_A, error interruption	C	
CFCAC	ASIC7 JPEG related interruption during internal processing at DMA_A	C	
CFCAD	ASIC7 JPEG related interruption during internal processing at DMA_A	C	
CFCAE	ASIC7 JPEG related interruption with multiple statuses during internal processing at DMA_A	C	
CFCAF	ASIC7 No EOI marker after the completion of transmitting the amount of codes set during expansion at DMA_A	C	
CFCB0	ASIC7 compressed data go beyond the set value during compression at DMA_A	C	
CFCB1	ASIC7 no EOI marker after the completion of transmitting the amount of codes set during compression at DMA_A	C	
CFCB2	ASIC7 target abort	C	
CFCB3	ASIC7 master abort	C	

Code	Item	Relevant electrical components, units, and options	Rank
CFCB4	ASIC7 forced suspension	• JPEG board	C
CFCB5	ASIC7 PCI master detects retry error		C
CFCB6	ASIC7 master read data parity error		C
CFCB7	ASIC7 master write data parity error		C
CFCB8	ASIC7 system error		C
CFCB9	ASIC7 sleep read data parity error		C
CFCBA	ASIC7 sleep write data parity error		C
CFCBB	ASIC7 address parity error		C
CFCD0	CPS2300Great watchdog timer error		• MFP board (MFPB)
CFCD1	CPS2300Great local bus error	C	
CFCD2	CPS2300Great sleep read data parity error	C	
CFCD3	CPS2300Great sleep write data parity error	C	
CFCD4	CPS2300Great address parity error	C	
CFCF0	PIC3400Great watchdog timer error	C	
CFCF1	PIC3400Great sleep read data parity error	C	
CFCF2	PIC3400Great sleep write data parity error	C	
CFCF3	PIC3400Great address parity error	C	
CFD00	ASIC117 first sheet DMA00 time out	C	
CFD01	ASIC117 first sheet DMA01 time out	C	
CFD02	ASIC117 first sheet DMA02 time out	C	
CFD03	ASIC117 first sheet DMA03 time out	C	
CFD04	ASIC117 first sheet DMA04 time out	C	
CFD05	ASIC117 first sheet DMA05 time out	C	
CFD06	ASIC117 first sheet DMA06 time out	C	
CFD07	ASIC117 first sheet DMA07 time out	C	
CFD08	ASIC117 first sheet DMA08 time out	C	
CFD09	ASIC117 first sheet DMA09 time out	C	
CFD0A	ASIC117 first sheet DMA10 time out	C	
CFD10	ASIC117 first sheet DMA16 time out	C	
CFD11	ASIC117 first sheet DMA17 time out	C	
CFD12	ASIC117 first sheet DMA18 time out	C	
CFD13	ASIC117 first sheet DMA19 time out	C	
CFD14	ASIC117 first sheet DMA20 time out	C	
CFD15	ASIC117 first sheet DMA21 time out	C	
CFD16	ASIC117 first sheet DMA22 time out	C	
CFD17	ASIC117 first sheet DMA23 time out	C	
CFD18	ASIC117 first sheet DMA24 time out	C	
CFD19	ASIC117 first sheet DMA25 time out	C	
CFD1A	ASIC117 first sheet DMA26 time out	C	
CFD1B	ASIC117 first sheet DMA27 time out	C	
CFD1C	ASIC117 first sheet DMA28 time out	C	

bizhub\_C353/C253/C203

Troubleshooting

Code	Item	Relevant electrical components, units, and options	Rank
CFD1D	ASIC117 first sheet DMA29 time out	• MFP board (MFPB)	C
CFD1E	ASIC117 first sheet DMA30 time out		C
CFD50	ASIC117 second sheet DMA00 time out	• External controller I/F board	C
CFD51	ASIC117 second sheet DMA01 time out		C
CFD52	ASIC117 second sheet DMA02 time out		C
CFD53	ASIC117 second sheet DMA03 time out		C
CFD54	ASIC117 second sheet DMA04 time out		C
CFD55	ASIC117 second sheet DMA05 time out		C
CFD56	ASIC117 second sheet DMA06 time out		C
CFD57	ASIC117 second sheet DMA07 time out		C
CFD58	ASIC117 second sheet DMA08 time out		C
CFD59	ASIC117 second sheet DMA09 time out		C
CFD5A	ASIC117 second sheet DMA10 time out		C
CFD60	ASIC117 second sheet DMA16 time out		C
CFD61	ASIC117 second sheet DMA17 time out		C
CFD62	ASIC117 second sheet DMA18 time out		C
CFD63	ASIC117 second sheet DMA19 time out		C
CFD64	ASIC117 second sheet DMA20 time out		C
CFD65	ASIC117 second sheet DMA21 time out		C
CFD66	ASIC117 second sheet DMA22 time out		C
CFD67	ASIC117 second sheet DMA23 time out		C
CFD68	ASIC117 second sheet DMA24 time out		C
CFD69	ASIC117 second sheet DMA25 time out		C
CFD6A	ASIC117 second sheet DMA26 time out		C
CFD6B	ASIC117 second sheet DMA27 time out		C
CFD6C	ASIC117 second sheet DMA28 time out		C
CFD6D	ASIC117 second sheet DMA29 time out		C
CFD6E	ASIC117 second sheet DMA30 time out		C
CFDA0	ASIC7 DMA_A time out		• JPEG board
CFDA1	ASIC7 DMA_C time out	C	
CFDA2	ASIC7 DMA_D time out	C	
CFE00	ASIC117 first sheet DMA00 time out	• MFP board (MFPB)	C
CFE01	ASIC117 first sheet DMA01 time out		C
CFE02	ASIC117 first sheet DMA02 time out		C
CFE03	ASIC117 first sheet DMA03 time out		C
CFE04	ASIC117 first sheet DMA04 time out		C
CFE05	ASIC117 first sheet DMA05 time out		C
CFE06	ASIC117 first sheet DMA06 time out		C
CFE07	ASIC117 first sheet DMA07 time out		C
CFE08	ASIC117 first sheet DMA08 time out	C	

Code	Item	Relevant electrical components, units, and options	Rank	
CFE09	ASIC117 first sheet DMA09 time out	• MFP board (MFPB)	C	
CFE0A	ASIC117 first sheet DMA10 time out		C	
CFE10	ASIC117 first sheet DMA16 time out		C	
CFE11	ASIC117 first sheet DMA17 time out		C	
CFE12	ASIC117 first sheet DMA18 time out		C	
CFE13	ASIC117 first sheet DMA19 time out		C	
CFE14	ASIC117 first sheet DMA20 time out		C	
CFE15	ASIC117 first sheet DMA21 time out		C	
CFE16	ASIC117 first sheet DMA22 time out		C	
CFE17	ASIC117 first sheet DMA23 time out		C	
CFE18	ASIC117 first sheet DMA24 time out		C	
CFE19	ASIC117 first sheet DMA25 time out		C	
CFE1A	ASIC117 first sheet DMA26 time out		C	
CFE1B	ASIC117 first sheet DMA27 time out		C	
CFE1C	ASIC117 first sheet DMA28 time out		C	
CFE1D	ASIC117 first sheet DMA29 time out		C	
CFE1E	ASIC117 first sheet DMA30 time out		C	
CFE50	ASIC117 second sheet DMA00 time out		• External controller I/F board	C
CFE51	ASIC117 second sheet DMA01 time out			C
CFE52	ASIC117 second sheet DMA02 time out	C		
CFE53	ASIC117 second sheet DMA03 time out	C		
CFE54	ASIC117 second sheet DMA04 time out	C		
CFE55	ASIC117 second sheet DMA05 time out	C		
CFE56	ASIC117 second sheet DMA06 time out	C		
CFE57	ASIC117 second sheet DMA07 time out	C		
CFE58	ASIC117 second sheet DMA08 time out	C		
CFE59	ASIC117 second sheet DMA09 time out	C		
CFE5A	ASIC117 second sheet DMA10 time out	C		
CFE60	ASIC117 second sheet DMA16 time out	C		
CFE61	ASIC117 second sheet DMA17 time out	C		
CFE62	ASIC117 second sheet DMA18 time out	C		
CFE63	ASIC117 second sheet DMA19 time out	C		
CFE64	ASIC117 second sheet DMA20 time out	C		
CFE65	ASIC117 second sheet DMA21 time out	C		
CFE66	ASIC117 second sheet DMA22 time out	C		
CFE67	ASIC117 second sheet DMA23 time out	C		
CFE68	ASIC117 second sheet DMA24 time out	C		
CFE69	ASIC117 second sheet DMA25 time out	C		
CFE6A	ASIC117 second sheet DMA26 time out	C		
CFE6B	ASIC117 second sheet DMA27 time out	C		

bizhub\_C353/C253/C203

Troubleshooting

Code	Item	Relevant electrical components, units, and options	Rank
CFE6C	ASIC117 second sheet DMA28 time out	• External controller I/F board	C
CFE6D	ASIC117 second sheet DMA29 time out		C
CFE6E	ASIC117 second sheet DMA30 time out		C
CFEA0	ASIC7 DMA_A time out	• JPEG board	C
CFEA1	ASIC7 DMA_C time out		C
CFEA2	ASIC7 DMA_D time out		C
CFF00	ASIC117 first sheet DMA00 time out	• MFP board (MFPB)	C
CFF01	ASIC117 first sheet DMA01 time out		C
CFF02	ASIC117 first sheet DMA02 time out		C
CFF03	ASIC117 first sheet DMA03 time out		C
CFF04	ASIC117 first sheet DMA04 time out		C
CFF05	ASIC117 first sheet DMA05 time out		C
CFF06	ASIC117 first sheet DMA06 time out		C
CFF07	ASIC117 first sheet DMA07 time out		C
CFF08	ASIC117 first sheet DMA08 time out		C
CFF09	ASIC117 first sheet DMA09 time out		C
CFF0A	ASIC117 first sheet DMA10 time out		C
CFF10	ASIC117 first sheet DMA16 time out		C
CFF11	ASIC117 first sheet DMA17 time out		C
CFF12	ASIC117 first sheet DMA18 time out		C
CFF13	ASIC117 first sheet DMA19 time out		C
CFF14	ASIC117 first sheet DMA20 time out		C
CFF15	ASIC117 first sheet DMA21 time out		C
CFF16	ASIC117 first sheet DMA22 time out		C
CFF17	ASIC117 first sheet DMA23 time out		C
CFF18	ASIC117 first sheet DMA24 time out		C
CFF19	ASIC117 first sheet DMA25 time out		C
CFF1A	ASIC117 first sheet DMA26 time out		C
CFF1B	ASIC117 first sheet DMA27 time out		C
CFF1C	ASIC117 first sheet DMA28 time out		C
CFF1D	ASIC117 first sheet DMA29 time out	C	
CFF1E	ASIC117 first sheet DMA30 time out	C	
CFF50	ASIC117 second sheet DMA00 time out	• External controller I/F board	C
CFF51	ASIC117 second sheet DMA01 time out		C
CFF52	ASIC117 second sheet DMA02 time out		C
CFF53	ASIC117 second sheet DMA03 time out		C
CFF54	ASIC117 second sheet DMA04 time out		C
CFF55	ASIC117 second sheet DMA05 time out		C
CFF56	ASIC117 second sheet DMA06 time out		C
CFF57	ASIC117 second sheet DMA07 time out		C

Code	Item	Relevant electrical components, units, and options	Rank
CFF58	ASIC117 second sheet DMA08 time out	• External controller I/F board	C
CFF59	ASIC117 second sheet DMA09 time out		C
CFF5A	ASIC117 second sheet DMA10 time out		C
CFF60	ASIC117 second sheet DMA16 time out		C
CFF61	ASIC117 second sheet DMA17 time out		C
CFF62	ASIC117 second sheet DMA18 time out		C
CFF63	ASIC117 second sheet DMA19 time out		C
CFF64	ASIC117 second sheet DMA20 time out		C
CFF65	ASIC117 second sheet DMA21 time out		C
CFF66	ASIC117 second sheet DMA22 time out		C
CFF67	ASIC117 second sheet DMA23 time out		C
CFF68	ASIC117 second sheet DMA24 time out		C
CFF69	ASIC117 second sheet DMA25 time out		C
CFF6A	ASIC117 second sheet DMA26 time out		C
CFF6B	ASIC117 second sheet DMA27 time out		C
CFF6C	ASIC117 second sheet DMA28 time out		C
CFF6D	ASIC117 second sheet DMA29 time out		C
CFF6E	ASIC117 second sheet DMA30 time out		C
CFFA0	ASIC7 DMA_A time out	• JPEG board	C
CFFA1	ASIC7 DMA_C time out		C
CFFA2	ASIC7 DMA_D time out		C

### 16.4 How to reset

- Different malfunction resetting procedures apply depending on the rank of the trouble code.

\* List of malfunction resetting procedures

Trouble code rank	Resetting procedures
Rank A	<ul style="list-style-type: none"> <li>• Trouble reset</li> </ul> <p><a href="#">For details of Trouble Reset, see Adjustment/Setting. See P.450</a></p>
Rank B	<ul style="list-style-type: none"> <li>• Opening/closing the front door</li> </ul>
Rank C	<ul style="list-style-type: none"> <li>• Turning main power switch OFF/ON</li> </ul>



## 16.5 Solution

### 16.5.1 C0202: Tray 1 feeder up/down abnormality

Relevant parts	
Paper feed tray 1 lift-up motor (M8) Paper feed tray 1 upper limit sensor (PS8)	Printer control board (PRCB)

Step	Action	WIRING DIAGRAM	
		Control signal	Location (Electrical component)
1	Check the M8 connector for proper connection and correct as necessary.	—	—
2	Check the connector of M8 for proper drive coupling and correct as necessary.	—	—
3	PS8 I/O check, sensor check	PRCB CN12-3 (ON)	D-8
4	M8 operation check	PRCB CN11-4 (REM)	D-13
5	Change M8	—	—
6	Change PRCB	—	—

### 16.5.2 C0204: Tray 2 feeder up/down abnormality

Relevant parts	
Paper feed tray 2 lift-up motor (M9) Paper feed tray 2 upper limit sensor (PS15)	Printer control board (PRCB)

Step	Action	WIRING DIAGRAM	
		Control signal	Location (Electrical component)
1	Check the M9 connector for proper connection and correct as necessary.	—	—
2	Check the connector of M9 for proper drive coupling and correct as necessary.	—	—
3	PS15 I/O check, sensor check	PRCB CN9-3 (ON)	D-9
4	M9 operation check	PRCB CN7-9 (REM)	D-11
5	Change M9	—	—
6	Change PRCB	—	—

**16.5.3 C0211: Manual feed up/down abnormality**

Relevant parts	
Transport motor (M1) Manual pick-up solenoid (SL1) Manual lift-up position sensor (PS17)	Printer control board (PRCB)

Step	Action	WIRING DIAGRAM	
		Control signal	Location (Electrical component)
1	Check the M1 connector for proper connection and correct as necessary.	—	—
2	Check the connector of M1 for proper drive coupling and correct as necessary.	—	—
3	PS17 I/O check, sensor check	PRCB CN6-7 (ON)	D-2
4	SL1 operation check	PRCB CN6-4 (ON)	D-1
5	M1 operation check	PRCB CN34-10 (REM) PRCB CN34-13 (LOCK)	D-23
6	Change SL1	—	—
7	Change M1	—	—
8	Change PRCB	—	—

**16.5.4 C0301: Suction fan motor's failure to turn**

Relevant parts	
Suction fan motor (FM8)	Printer control board (PRCB)

Step	Action	WIRING DIAGRAM	
		Control signal	Location (Electrical component)
1	Check the FM8 connector for proper connection and correct as necessary.	—	—
2	Check the fan for possible overload and correct as necessary.	—	—
3	FM8 operation check	PRCB CN3-2 (ON) PRCB CN3-3 (LOCK)	D-5
4	Change the right door assy	—	—
5	Change PRCB	—	—

bizhub\_C353/C253/C203

Troubleshooting

**16.5.5 C0351: Paper cooling fan motor's failure to turn**

Relevant parts	
Paper cooling fan motor (FM7)	Printer control board (PRCB)



Step	Action	WIRING DIAGRAM	
		Control signal	Location (Electrical component)
1	Check the FM7 connector for proper connection and correct as necessary.	—	—
2	Check the fan for possible overload and correct as necessary.	—	—
3	FM7 operation check	PRCB CN39-14 (ON) PRCB CN39-15 (LOCK)	D-25
4	Change FM7	—	—
5	Change PRCB	—	—

**16.5.6 C2151: Secondary transfer roller pressure welding alienation**

Relevant parts	
2nd image transfer retraction motor (M11) 2nd image transfer welding alienation sensor (PS36)	Printer control board (PRCB)



Step	Action	WIRING DIAGRAM	
		Control signal	Location (Electrical component)
1	Check the M11 connector for proper connection and correct as necessary.	—	—
2	Check the connector of M11 for proper drive coupling and correct as necessary.	—	—
3	PS36 I/O check, sensor check	PRCB CN3-9 (ON)	D-5
4	Change the right door assy	—	—
5	Change PRCB	—	—

**16.5.7 C2152: Transfer belt pressure welding alienation**

Relevant parts	
Fusing motor (M5) Transfer belt retraction clutch (CL7) Transfer belt retraction sensor (PS31)	Printer control board (PRCB)

Step	Action	WIRING DIAGRAM	
		Control signal	Location (Electrical component)
1	Check the M5 connector for proper connection and correct as necessary.	—	—
2	PS31 I/O check, sensor check	PRCB CN36-15 (ON)	D-28
3	CL7 operation check	PRCB CN39-10 (ON)	D-25
4	M5 operation check	PRCB CN34-2 (REM) PRCB CN34-5 (LOCK)	D-23
5	Change CL7	—	—
6	Change M5	—	—
7	Change PRCB	—	—

**16.5.8 C2164: PC charge malfunction**

Relevant parts	
Imaging unit	High voltage unit (HV) Printer control board (PRCB)

Step	Action	WIRING DIAGRAM	
		Control signal	Location (Electrical component)
1	Check the imaging unit for proper connection and correct as necessary.	—	—
2	Check the HV connector for proper connection and correct as necessary.	—	—
3	Check the PRCB connector for proper connection and correct as necessary.	—	—
4	Change IU	—	—
5	Change HV	—	—
6	Change PRCB	—	—

bizhub\_C353/C253/C203

Troubleshooting

**16.5.9 C2253: Color PC motor's failure to turn****16.5.10 C2254: Color PC motor's turning at abnormal timing**

Relevant parts	
Color PC motor (M2)	Printer control board (PRCB)

Step	Action	WIRING DIAGRAM	
		Control signal	Location (Electrical component)
1	Check the M2 connector for proper connection and correct as necessary.	—	—
2	Check the M2 connector for proper drive coupling and correct as necessary.	—	—
3	Check the PRCB connector for proper connection and correct as necessary.	—	—
4	M2 operation check	PRCB CN35-4 (REM) PRCB CN35-7 (LOCK)	D-24
5	Change M2	—	—
6	Change PRCB	—	—

**16.5.11 C225D: Color dev. unit engagement/disengagement failure**

Relevant parts	
Color dev. unit engaged motor (M10) Color dev. unit engaged position sensor (PS26)	Printer control board (PRCB)

Step	Action	WIRING DIAGRAM	
		Control signal	Location (Electrical component)
1	Check the M10 connector for proper connection and correct as necessary.	—	—
2	Check the M10 connector for proper drive coupling and correct as necessary.	—	—
3	Check the PRCB connector for proper connection and correct as necessary.	—	—
4	PS26 I/O check, sensor check	PRCB CN39-18 (ON)	D-26
5	M10 operation check	PRCB CN39-12 (REM)	D-25
6	Change M10	—	—
7	Change PRCB	—	—

**16.5.12 C2351: K toner suction fan motor's failure to turn**

Relevant parts	
Toner suction fan motor (FM3)	Printer control board (PRCB)

Step	Action	WIRING DIAGRAM	
		Control signal	Location (Electrical component)
1	Check the FM3 connector for proper connection and correct as necessary.	—	—
2	Check the fan for possible overload and correct as necessary.	—	—
3	FM3 operation check	PRCB CN30-7 (ON) PRCB CN30-9 (LOCK)	K-7
4	Change FM3	—	—
5	Change PRCB	—	—

**16.5.13 C2451: Release new transfer belt unit**

Relevant parts	
Transfer belt unit	Printer control board (PRCB)

Step	Action	WIRING DIAGRAM	
		Control signal	Location (Electrical component)
1	Reinstall unit	—	—
2	Check there is a short circuit in the fuse of the transfer belt unit.	—	—
3	Check the PRCB connector for proper connection and correct as necessary.	—	—
4	Change PRCB	—	—

**16.5.14 C2551: Abnormally low toner density detected cyan TCR sensor****16.5.15 C2553: Abnormally low toner density detected magenta TCR sensor****16.5.16 C2555: Abnormally low toner density detected yellow TCR sensor**

Relevant parts	
Imaging unit /C Imaging unit /M Imaging unit /Y Toner cartridge /C Toner cartridge /M Toner cartridge /Y	Toner supply motor/CK (M3) Toner supply motor/YM (M4) Printer control board (PRCB)



Step	Action	WIRING DIAGRAM	
		Control signal	Location (Electrical component)
1	Reinstall imaging unit	—	—
2	Reinstall toner cartridge	—	—
3	M3, M4 operation check (At this time, IU must be non-installation.)	PRCB CN39-1 to 4 (M3) PRCB CN39-5 to 8 (M4)	D-24
4	Change imaging unit	—	—
5	Change PRCB.	—	—

**16.5.17 C2552: Abnormally high toner density detected cyan TCR sensor****16.5.18 C2554: Abnormally high toner density detected magenta TCR sensor****16.5.19 C2556: Abnormally high toner density detected yellow TCR sensor**

Relevant parts	
Imaging unit /C Imaging unit /M Imaging unit /Y Toner cartridge /C Toner cartridge /M Toner cartridge /Y	Printer control board (PRCB)

Step	Action	WIRING DIAGRAM	
		Control signal	Location (Electrical component)
1	Reinstall imaging unit	—	—
2	Reinstall toner cartridge	—	—
3	Change imaging unit	—	—
4	Change PRCB	—	—

**16.5.20 C2557: Abnormally low toner density detected black TCR sensor**

Relevant parts	
Imaging unit /K Toner cartridge /K	Toner supply motor/CK (M3) Printer control board (PRCB)

Step	Action	WIRING DIAGRAM	
		Control signal	Location (Electrical component)
1	M3 operation check (At this time, IU must be non-installation.)	PRCB CN39-1 to 4	D-24
2	Reinstall imaging unit	—	—
3	Reinstall toner cartridge	—	—
4	Change imaging unit /K	—	—
5	Change PRCB.	—	—

**16.5.21 C2558: Abnormally high toner density detected black TCR sensor**

Relevant parts	
Imaging unit /K Toner cartridge /K	Printer control board (PRCB)

Step	Action	WIRING DIAGRAM	
		Control signal	Location (Electrical component)
1	Reinstall imaging unit	—	—
2	Reinstall toner cartridge	—	—
3	Change imaging unit/K	—	—
4	Change PRCB	—	—



**16.5.22 C2559: Cyan TCR sensor adjustment failure**

**16.5.23 C255A: Magenta TCR sensor adjustment failure**

**16.5.24 C255B: Yellow TCR sensor adjustment failure**

Relevant parts	
Imaging unit /C Imaging unit /M Imaging unit /Y	Printer control board (PRCB)

Step	Action	WIRING DIAGRAM	
		Control signal	Location (Electrical component)
1	Reinstall imaging unit	—	—
2	Change imaging unit	—	—
3	Change PRCB	—	—

**16.5.25 C255C: Black TCR sensor adjustment failure**

Relevant parts	
Imaging unit /K	Printer control board (PRCB)

Step	Action	WIRING DIAGRAM	
		Control signal	Location (Electrical component)
1	Reinstall imaging unit /K	—	—
2	Change imaging unit /K	—	—
3	Change PRCB	—	—

**16.5.26 C2650: Main backup media access error**

Relevant parts			
Service EEPROM board (SV ERB)		Printer control board (PRCB)	
Step	Action	WIRING DIAGRAM	
		Control signal	Location (Electrical component)
1	Check the connector (CN23PRCB) on PRCB, the connector (CN1SV ERB) on SV ERB, and the harness between the boards for proper connection and correct as necessary.	—	—
2	<p>Change PRCB</p> <ol style="list-style-type: none"> <li>Turn OFF the main power switch and replace the current PRCB with a new one. (When using a PRCB of another machine in service, be sure to use a PRCB installed in the same model.)</li> </ol> <p><a href="#">See P.136</a></p> <ol style="list-style-type: none"> <li>Update the PRCB firmware.</li> <li>After completing the firmware update, turn OFF and ON the main power switch and check to see that warm-up is started. Make sure that malfunction codes other than C2650 or improper IU/TC placement is not detected.</li> <li>When the trouble cannot be solved, reinstall the removed PRCB to the original board.</li> </ol> <p><b>NOTE</b></p> <ul style="list-style-type: none"> <li><b>When taking the above steps, check whether PRCB is defective or not without replacing the SV ERB.</b></li> </ul>	—	—
3	<p>Change SV ERB</p> <ol style="list-style-type: none"> <li>Replace the current SV ERB with a new one. <a href="#">See P.143</a></li> <li>Turn ON the main power switch and check to see that warm-up is started. (One minute is spent to prepare the new SV ERB for use. During the period, the control panel backlight stays off.) Make sure that malfunction codes other than C2650 or improper IU/TC placement is not detected.</li> <li>Make the specified readjustments. <a href="#">See P.143</a></li> </ol>	—	—
4	If the above actions do not solve the problem, contact KMBT.	—	—

bizhub C353/C253/C203

Troubleshooting

- 16.5.27 C2651: EEPROM access error (IU C)**  
**16.5.28 C2652: EEPROM access error (IU M)**  
**16.5.29 C2653: EEPROM access error (IU Y)**  
**16.5.30 C2654: EEPROM access error (IU K)**

Relevant parts	
Imaging unit /C Imaging unit /M Imaging unit /Y Imaging unit /K	Printer control board (PRCB)

Step	Action	WIRING DIAGRAM	
		Control signal	Location (Electrical component)
1	Clean the connection between the imaging unit and the machine if dirty	—	—
2	Reinstall imaging unit	—	—
3	Check the harness for proper connection and correct as necessary.	—	—
4	Change imaging unit	—	—
5	Change PRCB	—	—

- 16.5.31 C2A01: EEPROM access error (TC C)**  
**16.5.32 C2A02: EEPROM access error (TC M)**  
**16.5.33 C2A03: EEPROM access error (TC Y)**  
**16.5.34 C2A04: EEPROM access error (TC K)**

Relevant parts	
Toner cartridge /C Toner cartridge /M Toner cartridge /Y Toner cartridge /K	Printer control board (PRCB)

Step	Action	WIRING DIAGRAM	
		Control signal	Location (Electrical component)
1	Clean the connection between the toner cartridge and the machine if dirty.	—	—
2	Reinstall toner cartridge	—	—
3	Check the harness for proper connection and correct as necessary.	—	—
4	Change toner cartridge	—	—
5	Check that CN29 harness on PRCB has a ferrite core. If not, attach the ferrite core to the harness.	—	—
6	Change PRCB	—	—

**16.5.35 C3101: Fusing roller separation failure**

Relevant parts	
Fusing retraction motor (M12) Fusing roller retraction sensor (PS38)	Printer control board (PRCB) Fusing unit



Step	Action	WIRING DIAGRAM	
		Control signal	Location (Electrical component)
1	Check the M12 connector for proper connection and correct as necessary.	—	—
2	PS38 I/O check, sensor check	PRCB CN28-8 (ON)	D-26
3	M12 operation check	PRCB CN28-4 to 5	D-26
4	Change M12	—	—
5	Change fusing unit	—	—
6	Change PRCB	—	—

**16.5.36 C3201: Fusing motor failure to turn**

**16.5.37 C3202: Fusing motor turning at abnormal timing**

Relevant parts	
Fusing motor (M5)	Printer control board (PRCB)



Step	Action	WIRING DIAGRAM	
		Control signal	Location (Electrical component)
1	Check the M5 connector for proper connection and correct as necessary.	—	—
2	Check the loading status of the fusing unit drive, and correct the error as necessary.	—	—
3	Check the fusing unit, PRCB for proper connection and correct or change as necessary.	—	—
4	M5 operation check	PRCB CN34-2 (REM) PRCB CN34-5 (LOCK)	D-23
5	Change M5	—	—
6	Change PRCB	—	—

**16.5.38 C3303: Fusing cooling fan motor/ 1 failure to turn**

Relevant parts	
Fusing cooling fan motor/1 (FM9)	Printer control board (PRCB)



Step	Action	WIRING DIAGRAM	
		Control signal	Location (Electrical component)
1	Check the FM9 connector for proper connection and correct as necessary.	—	—
2	Check the fan for possible overload and correct as necessary.	—	—
3	FM9 operation check	PRCB CN40-2 (ON) PRCB CN40-3 (LOCK)	D-20
4	Change FM9	—	—
5	Change PRCB	—	—

**16.5.39 C3302: Fusing cooling fan motor/ 2,3 failure to turn**

Relevant parts	
Fusing cooling fan motor/2 (FM10) Fusing cooling fan motor/3 (FM11)	Printer control board (PRCB)



Step	Action	WIRING DIAGRAM	
		Control signal	Location (Electrical component)
1	Check the FM10 or FM11 connector for proper connection and correct as necessary.	—	—
2	Check the fan for possible overload and correct as necessary.	—	—
3	FM10/FM11 operation check	PRCB CN40-5 (ON) PRCB CN40-6 (LOCK)	D-20
		PRCB CN40-8 (ON) PRCB CN40-9 (LOCK)	D-20
4	Change FM10/FM11	—	—
5	Change PRCB	—	—

**16.5.40 C3421: Fusing heaters trouble (heating side)****16.5.41 C3423: Fusing heaters trouble (pressurizing side)**

Relevant parts			
Fusing unit		DC power supply (DCPU) Printer control board (PRCB)	
Step	Action	WIRING DIAGRAM	
		Control signal	Location (Electrical component)
1	Check the fusing unit for correct installation (whether it is secured in position).	—	—
2	Check the open/close operation of the upper right door.	—	—
3	Check the fusing unit, PRCB and DCPU for proper connection and correct or change as necessary.	—	—
4	Change fusing unit	—	—
5	Change PRCB	—	—
6	Change DCPU	—	—

**16.5.42 C3461: Release new fusing unit**

Relevant parts			
Fusing unit		Printer control board (PRCB)	
Step	Action	WIRING DIAGRAM	
		Control signal	Location (Electrical component)
1	Check the fusing unit for correct installation (whether it is secured in position).	—	—
2	Check the fusing unit, PRCB for proper connection and correct or change as necessary.	—	—
3	Reinstall fusing unit	—	—
4	Change fusing unit	—	—
5	Change PRCB	—	—

**16.5.43 C3721: Fusing abnormally high temperature detection (heating side)****16.5.44 C3723: Fusing abnormally high temperature detection (pressurizing side)**

Relevant parts	
Fusing unit	DC power supply (DCPU) Printer control board (PRCB)

Step	Action	WIRING DIAGRAM	
		Control signal	Location (Electrical component)
1	Check the fusing unit for correct installation (whether it is secured in position).	—	—
2	Check the open/close operation of the upper right door.	—	—
3	Check the fusing unit, PRCB and DCPU for proper connection and correct or change as necessary.	—	—
4	Change fusing unit	—	—
5	Change PRCB	—	—
6	Change DCPU	—	—

**16.5.45 C3821: Fusing abnormally low temperature detection (heating side)****16.5.46 C3823: Fusing abnormally low temperature detection (pressurizing side)**

Relevant parts	
Fusing unit	DC power supply (DCPU) Printer control board (PRCB)

Step	Action	WIRING DIAGRAM	
		Control signal	Location (Electrical component)
1	Check the fusing unit for correct installation (whether it is secured in position).	—	—
2	Check the open/close operation of the upper right door.	—	—
3	Check the fusing unit, PRCB and DCPU for proper connection and correct or change as necessary.	—	—
4	Change fusing unit	—	—
5	Change PRCB	—	—
6	Change DCPU	—	—

- 16.5.47 C4151: Polygon motor rotation trouble (C)**
- 16.5.48 C4152: Polygon motor rotation trouble (M)**
- 16.5.49 C4153: Polygon motor rotation trouble (Y)**
- 16.5.50 C4154: Polygon motor rotation trouble (K)**

Relevant parts	
PH unit	PH relay board (REYB/PH) Printer control board (PRCB)

Step	Action	WIRING DIAGRAM	
		Control signal	Location (Electrical component)
1	Check the connector for proper connection and correct as necessary.	—	—
2	Change PH unit	—	—
3	Change REYB/PH	—	—
4	Change PRCB	—	—

- 16.5.51 C4551: Laser malfunction (C)**
- 16.5.52 C4552: Laser malfunction (M)**
- 16.5.53 C4553: Laser malfunction (Y)**
- 16.5.54 C4554: Laser malfunction (K)**

Relevant parts	
PH unit	PH relay board (REYB/PH) Printer control board (PRCB)

Step	Action	WIRING DIAGRAM	
		Control signal	Location (Electrical component)
1	Check the connector for proper connection and correct as necessary.	—	—
2	Change PH unit	—	—
3	Change REYB/PH	—	—
4	Change PRCB	—	—



**16.5.55 C5102: Transport motor's failure to turn****16.5.56 C5103: Transport motor's turning at abnormal timing**

Relevant parts	
Transport motor (M1)	Printer control board (PRCB)



Step	Action	WIRING DIAGRAM	
		Control signal	Location (Electrical component)
1	Check the M1 connector for proper connection and correct as necessary.	—	—
2	Check M1 for proper drive coupling and correct as necessary.	—	—
3	Check the PRCB connector for proper connection and correct as necessary.	—	—
4	M1 operation check	PRCB CN34-10 (REM) PRCB CN34-13 (LOCK)	D-23
5	Change M1	—	—
6	Change PRCB	—	—

**16.5.57 C5351: Power supply cooling fan motor's failure to turn**

Relevant parts	
Power supply cooling fan motor (FM5)	Printer control board (PRCB)



Step	Action	WIRING DIAGRAM	
		Control signal	Location (Electrical component)
1	Check the FM5 connector for proper connection and correct as necessary.	—	—
2	Check the fan for possible overload and correct as necessary.	—	—
3	FM5 operation check	PRCB CN30-11 (ON) PRCB CN30-12 (LOCK)	K-8
4	Change FM5	—	—
5	Change DCPU	—	—
6	Change PRCB	—	—

**16.5.58 C5353: Cooling fan motor/2's failure to turn**

Relevant parts	
Cooling fan motor/2 (FM2)	Printer control board (PRCB)

Step	Action	WIRING DIAGRAM	
		Control signal	Location (Electrical component)
1	Check the FM2 connector for proper connection and correct as necessary.	—	—
2	Check the fan for possible overload and correct as necessary.	—	—
3	FM2 operation check	PRCB CN28-2 (ON) PRCB CN28-3 (LOCK)	D-26
4	Change FM2	—	—
5	Change PRCB	—	—

**16.5.59 C5354: Exhaust fan motor's failure to turn**

Relevant parts	
Exhaust fan motor (FM4)	Printer control board (PRCB)

Step	Action	WIRING DIAGRAM	
		Control signal	Location (Electrical component)
1	Check the FM4 connector for proper connection and correct as necessary.	—	—
2	Check the fan for possible overload and correct as necessary.	—	—
3	FM4 operation check	PRCB CN3-14 (ON) PRCB CN3-16 (LOCK)	D-6
4	Change FM4	—	—
5	Change MFPB	—	—

**16.5.60 C5357: Cooling fan motor/1's failure to turn**

Relevant parts	
Cooling fan motor/1 (FM1)	Printer control board (PRCB)

Step	Action	WIRING DIAGRAM	
		Control signal	Location (Electrical component)
1	Check the FM1 connector for proper connection and correct as necessary.	—	—
2	Check the fan for possible overload and correct as necessary.	—	—
3	FM1 operation check	PRCB CN30-4 (ON) PRCB CN30-6 (LOCK)	K-7
4	Change FM1	—	—
5	Change PRCB	—	—

**16.5.61 C5370: MFP board cooling fan motor's failure to turn**

Relevant parts	
MFP board cooling fan motor (FM6)	MFP board (MFPB) Printer control board (PRCB)

Step	Action	WIRING DIAGRAM	
		Control signal	Location (Electrical component)
1	Check the FM6 connector for proper connection and correct as necessary.	—	—
2	Check the fan for possible overload and correct as necessary.	—	—
3	FM6 operation check	PRCB CN44-1 (REM) PRCB CN44-3 (LOCK)	K-9
4	Change FM6	—	—
5	Change PRCB	—	—
6	Change MFPB	—	—

**16.5.62 C5371: MFP board CPU cooling fan motor's failure to turn**

Relevant parts			
MFP board CPU cooling fan motor		MFP board (MFPB)	
Step	Action	WIRING DIAGRAM	
		Control signal	Location (Electrical component)
1	Check the MFP board CPU cooling fan motor connector for proper connection and correct as necessary.	—	—
2	Check the fan for possible overload and correct as necessary.	—	—
3	MFP board CPU cooling fan motor operation check	MFPB PJ20-3 (LOCK)	Q-23
4	Change MFPB	—	—

**16.5.63 C6102: Drive system home sensor malfunction**

**16.5.64 C6103: Slider over running**

Relevant parts			
Scanner home sensor (PS201) Scanner motor (M201)		Scanner relay board (REYB/SCAN) Image processing board (IPB)	
Step	Action	WIRING DIAGRAM	
		Control signal	Location (Electrical component)
1	Correct or change the scanner drive (cable, pulley, gear, belt) if it is faulty.	—	—
2	Correct the scanner motor set screw if loose.	—	—
3	Adjust [Image Position Leading Edge] and [Feed Direction Adjustment].	—	—
4	Check the PS201, M201, REYB/SCAN and IPB connector for proper connection and correct as necessary.	—	—
5	PS201 I/O check, sensor check	IPB CN11-3 (ON)	U-8
6	M201 operation check	REYB/SCAN CN5-4 to 7	R-11
7	Change REYB/SCAN.	—	—
8	Change IPB.	—	—

**16.5.65 C6301: Optical cooling fan motor's failure to turn**

Relevant parts	
Optical cooling fan motor (FM201)	Scanner relay board (REYB/SCAN) Image processing board (IPB)

Step	Action	WIRING DIAGRAM	
		Control signal	Location (Electrical component)
1	Check the FM201 connector for proper connection and correct as necessary.	—	—
2	Check the fan for possible overload and correct as necessary.	—	—
3	FM201 operation check	REYB/SCAN CN2-3 (LOCK)	R-12
4	Change REYB/SCAN	—	—
5	Change IPB	—	—

**16.5.66 C6704: Image input time out**

Relevant parts	
MFP board (MFPB)	Image processing board (IPB)

Step	Action	WIRING DIAGRAM	
		Control signal	Location (Electrical component)
1	Select [Service Mode] → [State Confirmation] → [Memory/HDD Adj.] → [Memory Bus Check] → [Scanner→Memory], and conduct the memory bus function.	—	—
2	Check the connectors between IPB and MFPB for proper connection and correct as necessary.	—	—
3	Change MFPB	—	—
4	Change IPB	—	—

**16.5.67 C6751: CCD clamp/gain adjustment failure**

Relevant parts	
Scanner assy	CCD sensor unit Image processing board (IPB)

Step	Action	WIRING DIAGRAM	
		Control signal	Location (Electrical component)
1	Correct the harness connection between CCDB and IPB if faulty.	—	—
2	Check for possible extraneous light and correct as necessary.	—	—
3	Clean the lens, mirrors, CCD surface, and shading sheet if dirty	—	—
4	Correct reflective mirror of the scanner if faulty, or change scanner.	—	—
5	Change CCD sensor unit	—	—
6	Change IPB	—	—

**16.5.68 C6F01: Scanner sequence trouble 1**

Relevant parts	
MFP board (MFPB)	DF control board (DFCB)

Step	Action	WIRING DIAGRAM	
		Control signal	Location (Electrical component)
1	Correct the harness connection between main body and ADF if faulty.	—	—
2	Change DFCEB	—	—
3	Change MFPB	—	—

**16.5.69 C9401: Exposure turning on the lamp trouble detection**

**16.5.70 C9402: Exposure turning on the lamp abnormally detection**

Relevant parts	
Scanner assy Flat cable	Inverter board (INVB) CCD board (CCDB) Scanner relay board (REYB/SCAN) Image processing board (IPB)

Step	Action	WIRING DIAGRAM	
		Control signal	Location (Electrical component)
1	Check the connection between the lamp harness and the inverter board, and correct if necessary.	—	—
2	Check the connection between REYB/SCAN and the inverter board, and correct if necessary.	—	—
3	Check the connection between REYB/SCAN and IPB, and correct if necessary.	—	—
4	Check that the connection between CCDB and IPB, and correct if necessary.	—	—
5	Change INVB	—	—
6	Change scanner assy	—	—
7	Change IPB	—	—
8	Change CCDB	—	—
9	Change REYB/SCAN	—	—

**16.5.71 CA051: Standard controller configuration failure**

**16.5.72 CA052: Controller hardware error**

**16.5.73 CA053: Controller start failure**

Relevant parts	
MFP board (MFPB)	

Step	Action	WIRING DIAGRAM	
		Control signal	Location (Electrical component)
1	Check to see if the following setting has been correctly made: [Service Mode] → [System 2] → [Image Controller Setting]. If changing the setting, turn OFF the main power switch and turn it ON again after 10 seconds or more.	—	—
2	Check the connectors of the MFP board (MFPB) for proper connection and correct as necessary.	—	—
3	Change MFPB	—	—

**16.5.74 CC001: Vendor connection failure**

Relevant parts	
Printer control board (PRCB)	Coin vendor (Japan) Coin vendor kit (North America, Europe)

Step	Action	WIRING DIAGRAM	
		Control signal	Location (Electrical component)
1	Check the vendor connector for proper connection and correct as necessary.	—	—
2	Check the PRCB connector for proper connection and correct as necessary.	—	—
3	Change PRCB	—	—

**16.5.75 CC151: ROM contents error upon startup (MSC)**

**16.5.76 CC152: ROM contents error upon startup (Scanner)**

**16.5.77 CC153: ROM contents error upon startup (PRT)**

Step	Action	WIRING DIAGRAM	
		Control signal	Location (Electrical component)
1	Check the ROM version.	—	—
2	Rewrite the firmware.	—	—
3	Replace the appropriate board.	—	—



## 16.5.78 CC163: ROM contents error (PRT)

Relevant parts	
Service EEPROM board (SV ERB)	Printer control board (PRCB)

Step	Action	WIRING DIAGRAM	
		Control signal	Location (Electrical component)
1	Rewrite the firmware.	—	—
2	<p>Change PRCB</p> <ol style="list-style-type: none"> <li>1. Turn OFF the main power switch and replace the current PRCB with a new one. (When using a PRCB of another machine in service, be sure to use a PRCB installed in the same model.) <a href="#">See P.136</a></li> <li>2. Update the PRCB firmware.</li> <li>3. After completing the firmware update, turn OFF and ON the main power switch and check to see that warm-up is started.</li> <li>4. When the trouble cannot be solved, reinstall the removed PRCB to the original board.</li> </ol> <p><b>NOTE</b></p> <ul style="list-style-type: none"> <li>• <b>When taking the above steps, check whether PRCB is defective or not without replacing the SV ERB.</b></li> </ul>	—	—
3	<p>Change SV ERB</p> <ol style="list-style-type: none"> <li>1. Replace the current SV ERB with a new one. <a href="#">See P.143</a></li> <li>2. Turn ON the main power switch and check to see that warm-up is started. (One minute is spent to prepare the new SV ERB for use. During the period, the control panel backlight stays off.)</li> <li>3. Make the specified readjustments. <a href="#">See P.143</a></li> </ol>	—	—
4	If the above actions do not solve the problem, contact KMBT.	—	—

**16.5.79 CC164: ROM contents error (MSC)**

Relevant parts			
Printer control board (PRCB)		MFP board (MFPB)	
Step	Action	WIRING DIAGRAM	
		Control signal	Location (Electrical component)
1	Check the ROM version.	—	—
2	Rewrite the firmware.	—	—
3	Replace the corresponding board.	—	—
4	When not reviving even if the above-mentioned procedure is done, contact the responsible people of KMBT.	—	—

**16.5.80 CC170: Dynamic link error during starting (AP0)**

**16.5.81 CC171: Dynamic link error during starting (AP1)**

**16.5.82 CC172: Dynamic link error during starting (AP2)**

**16.5.83 CC173: Dynamic link error during starting (AP3)**

**16.5.84 CC174: Dynamic link error during starting (AP4)**

**16.5.85 CC180: Dynamic link error during starting (LDR)**

**16.5.86 CC181: Dynamic link error during starting (IBR)**

**16.5.87 CC182: Dynamic link error during starting (IID)**

**16.5.88 CC183: Dynamic link error during starting (IPF)**

**16.5.89 CC184: Dynamic link error during starting (IMY)**

Relevant parts			
MFP board (MFPB)		NVRAM board (NRB)	
Step	Action	WIRING DIAGRAM	
		Control signal	Location (Electrical component)
1	If the malfunction code “C-C172” has occurred, access [Service Mode] → [System 2] → [Image Controller Setting] and check to see if “Controller 2,” “Controller 3,” or “Others” is set for [Image Controller Setting]. If any of these is set, according to the kind of controller, select “Controller 0” or “Controller 1.”	—	—
2	Change MFPB.	—	—
3	When not reviving even if the above-mentioned procedure is done, contact the responsible people of KMBT.	—	—

**16.5.90 CD002: JOB RAM save error**

Relevant parts			
MFP board (MFPB)		Hard disk	
Step	Action	WIRING DIAGRAM	
		Control signal	Location (Electrical component)
1	Check the hard disk connector for proper connection and correct as necessary.	—	—
2	Format hard disk.	—	—
3	Change hard disk.	—	—
4	Change MFPB.	—	—

**16.5.91 CD004: Hard disk access error****16.5.92 CD005: Hard disk error 1****16.5.93 CD006: Hard disk error 2****16.5.94 CD007: Hard disk error 3****16.5.95 CD008: Hard disk error 4****16.5.96 CD009: Hard disk error 5****16.5.97 CD00A: Hard disk error 6****16.5.98 CD00B: Hard disk error 7****16.5.99 CD00C: Hard disk error 8****16.5.100 CD00D: Hard disk error 9****16.5.101 CD00E: Hard disk error A****16.5.102 CD00F: Hard disk data transfer error****16.5.103 CD020: Hard disk verify error**

Relevant parts			
MFP board (MFPB)		Hard disk	
Step	Action	WIRING DIAGRAM	
		Control signal	Location (Electrical component)
1	Check the hard disk connector for proper connection and correct as necessary.	—	—
2	Reinstall the hard disk.	—	—
3	Change hard disk.	—	—
4	Change MFPB.	—	—

**16.5.104 CD010: Hard disk unformat**

Relevant parts			
MFP board (MFPB)		Hard disk	
Step	Action	WIRING DIAGRAM	
		Control signal	Location (Electrical component)
1	Select [Service Mode] → [State Confirmation] → [Memory/HDD Adj.] → [HDD Format], and conduct the HDD format function.	—	—
2	Change hard disk.	—	—
3	Change MFPB	—	—

**16.5.105 CD011: Hard disk out of specifications mounted**

Relevant parts			
Hard disk			
Step	Action	WIRING DIAGRAM	
		Control signal	Location (Electrical component)
1	Check the hard disk specifications.	—	—
2	Change the hard disk.	—	—

**16.5.106 CD201: File memory mounting error**

**16.5.107 CD202: Memory capacity discrepancy**

**16.5.108 CD203: Memory capacity discrepancy 2**

Relevant parts			
MFP board (MFPB)		Memory	
Step	Action	WIRING DIAGRAM	
		Control Signal	Location (Electrical Component)
1	Check to see if the memory on MFPB is installed correctly.	—	—
2	Change the memory on MFPB.	—	—
3	Change MFPB.	—	—

**16.5.109 CD211: PCI-SDRAM DMA operation failure****16.5.110 CD212: Compression/extraction timeout detection**

Relevant parts			
MFP board (MFPB)			
Step	Action	WIRING DIAGRAM	
		Control Signal	Location (Electrical Component)
1	Change MFPB.	—	—

**16.5.111 CD231: No Fax memory at FAX board mounting**

Relevant parts			
MFP board (MFPB)		FAX board FAX memory	
Step	Action	WIRING DIAGRAM	
		Control Signal	Location (Electrical Component)
1	Check to see if the FAX memory is installed correctly.	—	—
2	Check to see if the FAX board is installed correctly.	—	—
3	Change FAX memory.	—	—
4	Change PRCB.	—	—

**16.5.112 CD241: Encryption board setting error****16.5.113 CD242: Encryption board mounting error**

Relevant parts			
Encryption board (SC-503)			
Step	Action	WIRING DIAGRAM	
		Control Signal	Location (Electrical Component)
1	Check the encryption board connector for proper connection and correct as necessary.	—	—
2	Change encryption board.	—	—

**16.5.114 CD251: No JPEG board mounting at JPEG board mount setting**

Relevant parts			
MFP board (MFPB)		JPEG board (SA-501)	
Step	Action	WIRING DIAGRAM	
		Control Signal	Location (Electrical Component)
1	Check the JPEG board connector for proper connection and correct as necessary.	—	—
2	Change JPEG board.	—	—
3	Change MFPB.	—	—

**16.5.115 CD261: USB host board failure**

Relevant parts			
MFP board (MFPB)		USB host board (EK-603)	
Step	Action	WIRING DIAGRAM	
		Control Signal	Location (Electrical Component)
1	Check that the USB device in use is compliant with the standard.	—	—
2	Check the operation with another USB device.	—	—
3	Check the USB host board connector for proper connection and correct as necessary.	—	—
4	Change USB host board.	—	—
5	Change MFPB.	—	—

 **16.5.116 CD271: i-Option activated and additional memory not installed**

Relevant parts			
MFP board (MFPB)		Memory for i-Option	
Step	Action	WIRING DIAGRAM	
		Control Signal	Location (Electrical Component)
1	Check the memory for proper connection and correct as necessary.	—	—
2	Change memory.	—	—
3	Change MFPB.	—	—

- 16.5.117 CD401: NACK command incorrect**
- 16.5.118 CD402: ACK command incorrect**
- 16.5.119 CD403: Checksum error**
- 16.5.120 CD404: Receiving packet incorrect**
- 16.5.121 CD405: Receiving packet analysis error**
- 16.5.122 CD406: ACK receiving timeout**
- 16.5.123 CD407: Retransmission timeout**

Relevant parts	
MFP board (MFPB)	

Step	Action	WIRING DIAGRAM	
		Control Signal	Location (Electrical Component)
1	Check whether there is a strong electromagnetic noise source near the main body.	—	—
2	Check the connectors on MFPB for proper connection and correct as necessary.	—	—
3	Change MFPB.	—	—

- 16.5.124 CE001: Abnormal message queue**
- 16.5.125 CE003: Task error**
- 16.5.126 CE004: Event error**
- 16.5.127 CE005: Memory access error**
- 16.5.128 CE006: Header access error**
- 16.5.129 CE007: DIMM initialize error**

Relevant parts	
MFP board (MFPB)	

Step	Action	WIRING DIAGRAM	
		Control signal	Location (Electrical component)
1	Check the connectors on MFPB for proper connection and correct as necessary.	—	—
2	Change MFPB.	—	—

### 16.5.130 CD3##: NVRAM data error

- When the data stored due to the NVRAM trouble is lost, backup data can be used for restoration.
- Trouble code [C-D370] will be displayed when multiple errors (over 5) of NVRAM data are detected, which can be restored with one restoration command.
- Data backup will be automatically performed every hour. Backup can also be performed manually with the following setting.

[Service Mode] → [Enhanced Security] → [NVRAM Data Back Up]

[See P.439](#)

1. When a trouble caused by NVRAM data error occurs, the screen below appears.

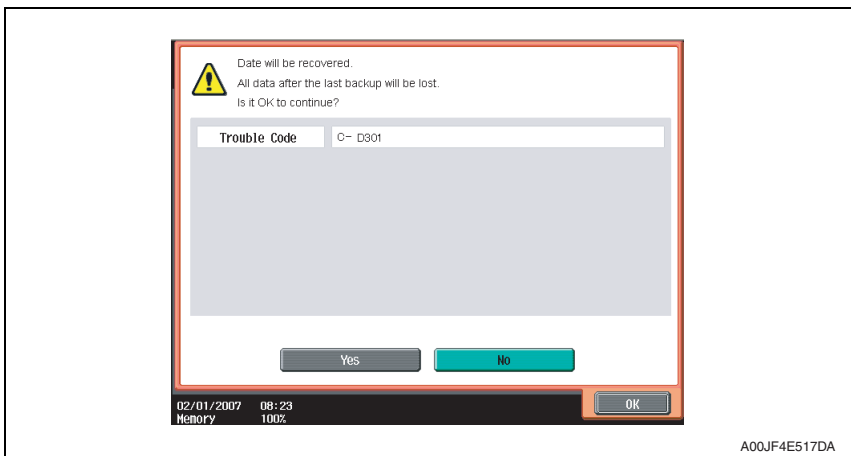

2. Select [Yes] and touch [OK].
3. The screen will be shifted to the data restoration screen to perform data restoration.

#### NOTE

- **When the restoration is performed in a short time, data restoration screen may not be displayed.**
4. Check the message which indicates that the data restoration was successfully conducted. Turn OFF the main power switch and turn it ON again more than 10 seconds after.

#### NOTE

- **In case it failed to restore data, return to the trouble code screen.**



**16.5.131 CE002: Message and method parameter failure**

Relevant parts			
MFP board (MFPB)		Hard disk	
Step	Action	WIRING DIAGRAM	
		Control signal	Location (Electrical component)
1	If it occurred after upgrading the firmware, conduct the following setting. [Service Mode] → [State Confirmation] → [Memory/HDD Adj.] → [HDD Version Up] <a href="#">See P.425</a>	—	—
2	Turn OFF the main power switch and turn it ON again, and conduct the following setting. [Service Mode] → [System 1] → [Initialization] → [Data Clear]. <a href="#">See P.390</a>	—	—
3	Format hard disk.	—	—
4	Change hard disk.	—	—
5	Change MFPB.	—	—

**16.5.132 CEEE1: MSC undefined malfunction occurring**

Relevant parts			
MFP board (MFPB)			
Step	Action	WIRING DIAGRAM	
		Control signal	Location (Electrical component)
1	Check the connectors on MFPB for proper connection and correct as necessary.	—	—
2	Change MFPB	—	—

**16.5.133 CEEE2: Scanner section undefined malfunction**

Relevant parts			
Scanner assy		CCD board (CCDB) Image processing board (IPB)	
Step	Action	WIRING DIAGRAM	
		Control signal	Location (Electrical component)
1	Correct the connector connection between CCDB and IPB if faulty.	—	—
2	Change IPB	—	—
3	Change CCDB	—	—

**16.5.134 CEEE3: Engine section undefined malfunction**

Relevant parts	
Printer control board (PRCB)	

Step	Action	WIRING DIAGRAM	
		Control signal	Location (Electrical component)
1	Check the PRCB connector for proper connection and correct as necessary.	—	—
2	Change PRCB	—	—

bizhub C353/C253/C203

Troubleshooting

## 17. Power supply trouble

### 17.1 Machine is not energized at all (DCPU operation check)

Relevant parts	
Main power switch (S1) Front door switch/1 (S3) Front door switch/2 (S4) Printer control board (PRCB)	DC power supply (DCPU)

Step	Check item	WIRING DIAGRAM (Location)	Result	Action
1	Is a power voltage supplied across CN1-1 and 2 on DCPU?	R to S-2	NO	Check the WIRING from the wall outlet to S1 to CN1.
2	Are the fuses on DCPU conducting?	—	NO	Change DCPU.
3	Is DC24 V being output from CN7-5 on DCPU?	P-7	NO	Change DCPU.
4	Is DC5 V being input to CN5-1 on DCPU?	P-6	NO	Change DCPU.
5	Is DC5 V being input to CN31-3 on the printer control board? (LED on PRCB does not blink.)	H to I-4	NO	Change DCPU.
			YES	Change PRCB.

### 17.2 Control panel indicators do not light.

Relevant parts	
Image processing board (IPB) Scanner relay board (REYB/SCAN) Control panel	JMP board (JMPB) DC power supply (DCPU)

Step	Check item	WIRING DIAGRAM (Location)	Result	Action
1	Is the I/F cable between the scanner and engine connected properly?	—	NO	Reconnect or change the I/F cable.
2	After the main or sub main power switch is turned ON, the blue and orange status indicator lights continue to be on while the control panel is not being displayed. Is JMPB (PJ17) securely set on the MFPB?	U to V-19	NO	Reconnect.
3	Is a power voltage being applied across CN1-1 and 2 on DCPU?	R to S-2	NO	Check the WIRING from the wall outlet to S1 to CN1.
4	Is the fuse on DCPU conducting?	—	NO	Change DCPU.
5	Is DC24 V being output from CN9-10 on DCPU and DC5 V from CN11-1?	Q-3	NO	Change DCPU.
6	Is CN1 on IPB securely connected?	T-9 to 10	NO	Reconnect.
7	Is CN6 on REYB/SCAN securely connected?	U to V-10	NO	Reconnect.

### 17.3 Fusing heaters do not operate

Relevant parts	
Main power switch (S1) Right door switch (S5) Fusing unit	DC power supply (DCPU)

Step	Check item	WIRING DIAGRAM (Location)	Result	Action
1	Is the power source voltage applied across CN7-5 on DCPU? During this time, the right door should be closed.	Q-7	NO	Check wiring from power outlet to S1 to CN7 to S5.
2	Is the power source voltage applied across CN47-1?	D-21	YES	Fusing unit
			NO	Change DCPU.

### 17.4 Power is not supplied to option

#### 17.4.1 DF-611

Step	Check item	WIRING DIAGRAM (Location)	Result	Action
1	Is DC24 V being output from CN5-1 on DF-611?	Y-12	YES	Malfuction in DF-611
2	Is DC24 V being output from CN9-9 on DCPU?	P-3	NO	Check wiring from DCPU to ADF.
3	Is the fuse on DCPU conducting?	—	YES	Change DCPU.
			NO	Malfuction in DF-611

#### 17.4.2 PC-104/204/405

Step	Check item	WIRING DIAGRAM (Location)	Result	Action
1	Is DC24 V being applied to hookup connector CN44-13?	J-16	NO	Malfuction in paper feed cabinet
2	Is DC24 V being output from CN14-2 on PRCB?	H-16	NO	Check wiring from PRCB to CN44 to paper feed cabinet.
3	Is the fuse on DCPU conducting?	—	YES	Change DCPU.
			NO	Malfuction in paper feed cabinet

**17.4.3 FS-519/JS-505/FS-609**

Step	Check item	WIRING DIAGRAM (Location)	Result	Action
1	Are DC24 V being applied to CN78L-1?	J-18	NO	Malfunction in FS-519/ JS-505/FS-609
2	Are DC24 V being applied to CN4-1 on DCPU?	Q-1	NO	Check wiring from DCPU to FS-519/JS-505/FS-609.
3	Is the fuse on DCPU conducting?	—	YES	Change DCPU.
			NO	Malfunction in FS-519/JS- 505/FS-609.

## 18. Image quality problem

### 18.1 How to read element date

- As part of troubleshooting procedures, the numeric values set for “State Confirmation” available from “Service Mode” can be used to isolate the cause of the image problem.

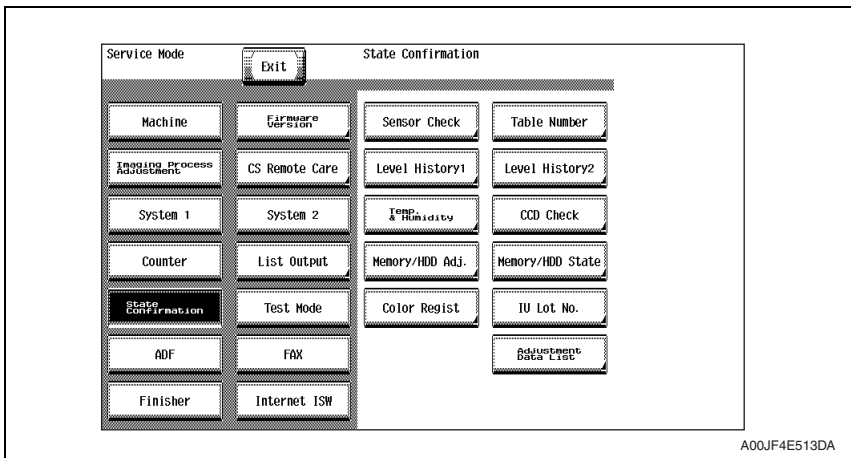

18.1.1 Table number

State Confirmation

END

Table No.

	Plain Paper	Thick Paper	Black		Plain Paper	Thick Paper	Black		
Vdc-C	-	0	0	0	Vg-C	-	0	0	0
Vdc-M	-	0	0	0	Vg-M	-	0	0	0
Vdc-Y	-	0	0	0	Vg-Y	-	0	0	0
Vdc-K	-	0	0	0	Vg-K	-	0	0	0

A02EF4E536DA

Vdc-C Vdc-M Vdc-Y Vdc-K	<ul style="list-style-type: none"> <li>Shows the developing bias value of each color of toner when an image is produced.</li> <li>Standard values: around 100 to 800 V</li> <li>A correction is made to make the image lighter when the numeric value is greater.</li> <li>A correction is made to make the image darker when the numeric value is smaller.</li> <li>Relevant Components: Imaging unit, high voltage unit (HV)</li> </ul>
Vg-C Vg-M Vg-Y Vg-K	<ul style="list-style-type: none"> <li>Shows the grid voltage value of each color of toner when an image is produced.</li> <li>Standard values: around 300 to 1100 V</li> <li>A correction is made to make the image lighter when the numeric value is greater.</li> <li>A correction is made to make the image darker when the numeric value is smaller.</li> <li>Relevant Components: Imaging unit, high voltage unit (HV)</li> </ul>

18.1.2 Level history 1

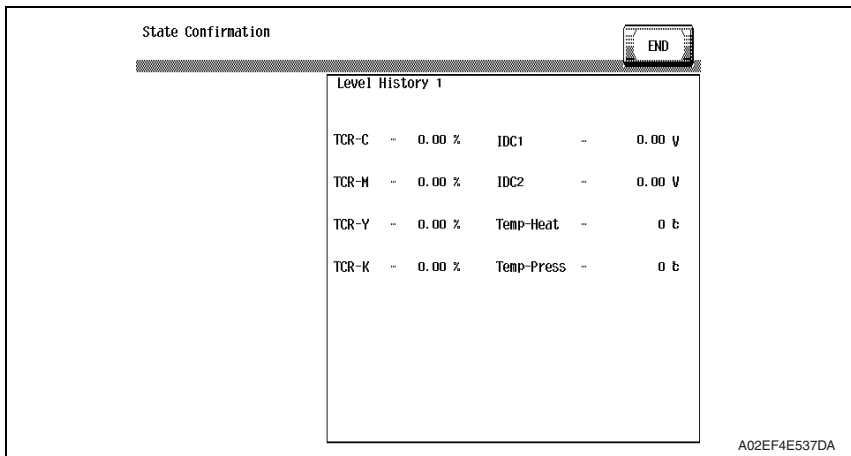

TCR-C TCR-M TCR-Y TCR-K	<ul style="list-style-type: none"> <li>Shows the T/C ratio reading taken last (in 0.01 % increments).</li> <li>Standard value: 6 to 8 %</li> <li>Relevant components: TCR sensor</li> <li>“Reading taken last” means: Latest value When the Start key is pressed, the output value is displayed while a test print is being produced.</li> </ul>
IDC1 IDC2	<ul style="list-style-type: none"> <li>Shows the IDC bare surface output reading taken last (in 0.01 V increments).</li> <li>It should normally be around 4.3 V.</li> <li>The output range is 0 V to 5 V.</li> <li>“Reading taken last” means: Present value</li> <li>Relevant components: IDC sensor, transfer belt unit</li> </ul>
Temp-Heat Temp-Press	<ul style="list-style-type: none"> <li>Shows the temperature of the each part of the fusing unit (in 1 °C increments).</li> <li>Relevant components: Fusing unit</li> </ul>



18.1.3 Level history 2

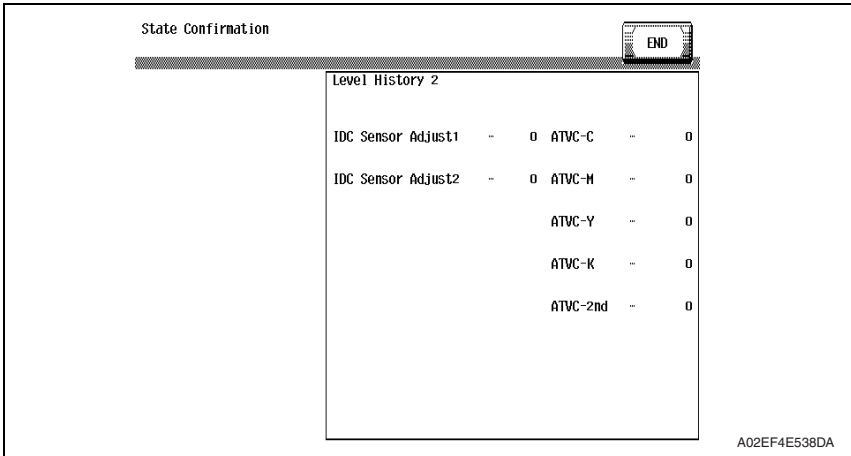

IDC Sensor Adjust 1 IDC Sensor Adjust 2	<ul style="list-style-type: none"> <li>Shows the IDC intensity adjustment value.</li> <li>It should normally be around 40 and can range from 0 to 255.</li> <li>The value becomes greater as the transfer belt unit has been used more.</li> <li>Relevant components: IDC sensor, transfer belt unit</li> </ul>
ATVC -C ATVC -M ATVC -Y ATVC -K ATVC -2nd	<ul style="list-style-type: none"> <li>Shows the latest ATVC level (which varies according to the paper type).</li> <li>5 <math>\mu</math>A to 40 <math>\mu</math>A (ATVC-C/-M/-Y/-K)</li> <li>300 V to 4800 V (ATVC-2nd)</li> <li>Relevant components: Transfer belt unit, High voltage unit (HV), 2nd transfer assy</li> </ul>

## 18.2 How to identify problematic part

- This chapter is divided into two parts: “Initial check items” and “Troubleshooting procedure by a particular image quality problem.”
- When an image quality problem occurs, first go through the “Initial check items” and, if the cause is yet to be identified, go to “Troubleshooting procedure by a particular image quality problem.”

### 18.2.1 Initial check items

#### A. Initial check items 1

- Check first to see if image data is properly transmitted between scanner and memory, and between memory and printer.

Action	Result	Next Step
Enter the Service Mode, select [State Confirmation] → [Memory/HDD Adj.] → [Memory Bus Check], and select and carry out [Scanner→Memory] and [Memory→PRT] checks.	OK	Initial check items 2
	NG	P.536 (action as instructed)

#### B. Initial check items 2

- Let the machine produce a test print and determine whether the image problem is attributable to the scanner or printer system.

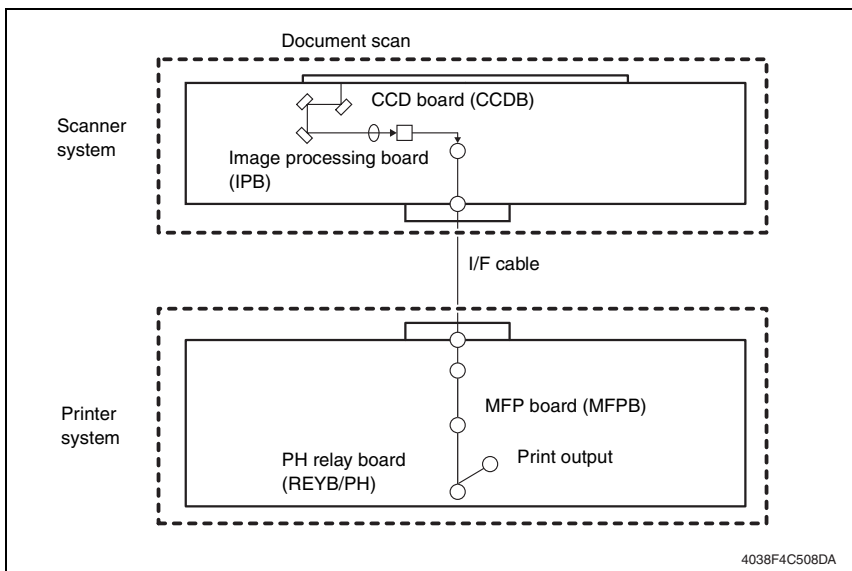

- Evaluation procedure

Image problem	Action	Result	Cause	Next step
Lines, bands	From [Service Mode], select [Test Mode] → [Halftone Pattern] → [SINGLE] → [HYPER] → [Gradation] → [C→M→Y→K] → [Density 64], and produce a test print. Is image problem evident?	YES	Printer	Initial check items 3
		NO	Scanner	P.559

**C. Initial check items 3**

- If the printer is responsible for the image problem, let the machine produce a test print and determine whether the image problem occurs in a specific single color or four colors

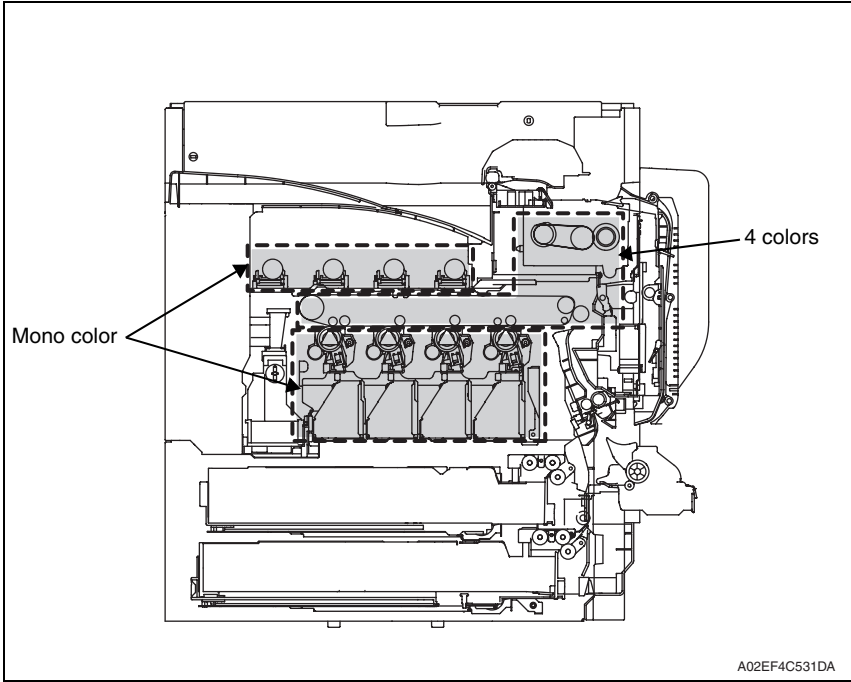

- Evaluation procedure

Image problem	Action	Result	Cause	Next step
Lines, bands	From [Service Mode], select [Test Mode] → [Halftone Pattern] → [SINGLE] → [HYPER] → [Gradation] → [C→M→Y→K] → [Density 64], and produce a test print. Is image problem evident in each of all four colors?	YES	Printer, 4 colors	<a href="#">P.588</a>
		NO	Printer, single color	<a href="#">P.574</a>

### 18.3 Solution

**NOTE**

- Typical faulty image samples shown in the following are all printed with A4S setting.

**18.3.1 Scanner system: white lines in sub scan direction, white bands in sub scan direction, colored lines in sub scan direction, and colored bands in sub scan direction**

**A. Typical faulty images**

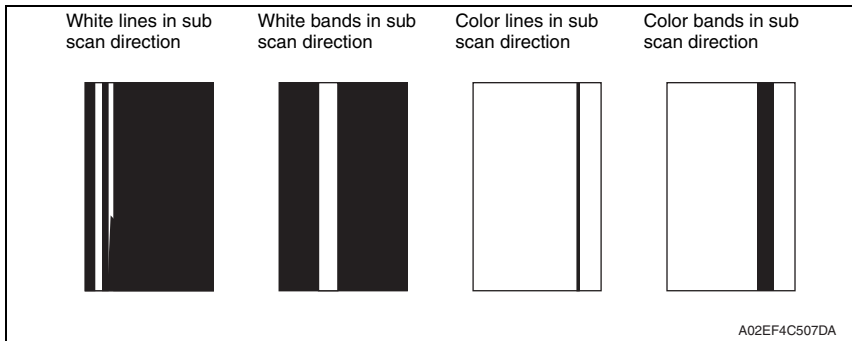

**B. Troubleshooting procedure**

**(1) When the original glass is used**

Step	Section	Check item	Result	Action
1	Original	Original is damaged or dirty.	YES	Change original.
2	ADF	Original pad is dirty.	YES	Clean.
3	Original glass	Original glass is dirty.	YES	Wipe the surface clean with a soft cloth.
4	Shading sheet	Shading sheet is dirty.	YES	Wipe the surface clean with a soft cloth.
5	Mirror, lens, exposure Lamp, and reflectors	Mirror is dirty	YES	Clean.
		Lens is dirty	YES	Clean.
		Exposure lamp is dirty	YES	Clean.
		Reflectors are dirty	YES	Clean.
6	Machine → Scan Area → Image Position: Side Edge (Service Mode)	The adjustment value for [Image Position: Side Edge] falls within the specified range.	NO	Readjust.
7		The white lines/bands or colored lines/bands are blurry.	YES	Change scanner assy. Change CCD unit.

bizhub C353/C253/C203

Troubleshooting

**(2) When the ADF is used**

Step	Section	Check item	Result	Action
1	Original	Original is damaged or dirty.	YES	Change original.
2	ADF reading section	Glass is dirty.	YES	Clean.
3	ADF scanning guide	ADF scanning guide is damaged or dirty.	YES	Clean.
4	Shading sheet	Shading sheet is dirty.	YES	Wipe the surface clean with a soft cloth.
5	Mirror, lens, exposure lamp, and reflectors	Mirror is dirty	YES	Clean.
		Lens is dirty	YES	Clean.
		Exposure lamp is dirty	YES	Clean.
		Reflectors are dirty	YES	Clean.
6	ADF → Original Stop Position (Service Mode)	The adjustment value for [Main Scanning Direction] falls within the specified range.	NO	Readjust.
7	Glass step sheet for the original glass moving unit	The glass step sheet is tilted.	YES	Readjust.
8	ADF read position	The white lines/bands or colored lines/bands occurs when reading the original from ADF.	YES	Readjust.
9		The white lines/bands or colored lines/bands are blurry.	YES	Change scanner assy. Change CCD unit.

**18.3.2 Scanner system: white lines in main scan direction, white bands in main scan direction, colored lines in main scan direction, and colored bands in main scan direction**

**A. Typical faulty images**

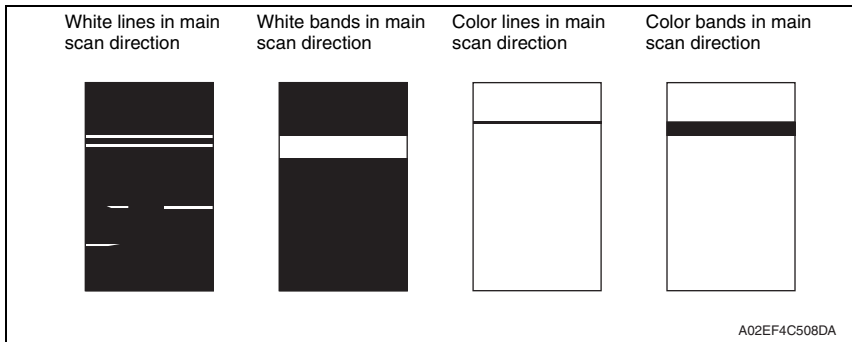

**B. Troubleshooting procedure**

Step	Section	Check item	Result	Action
1	Original	Original is damaged or dirty.	YES	Change original.
2	ADF	Original pad is dirty.	YES	Clean.
3	Original glass	Original glass is dirty.	YES	Wipe the surface clean with a soft cloth.
4	Machine → Scan Area → Image Position: Top Edge (Service Mode)	The adjustment value for [Image Position: Leading Edge] falls within the specified range.	NO	Readjust.
5		The problem has been eliminated through the checks of steps up to 4.	NO	Change scanner assy. Change CCD unit.

bizhub C353/C253/C203

Troubleshooting

### 18.3.3 Scanner system: color spots

#### A. Typical faulty images

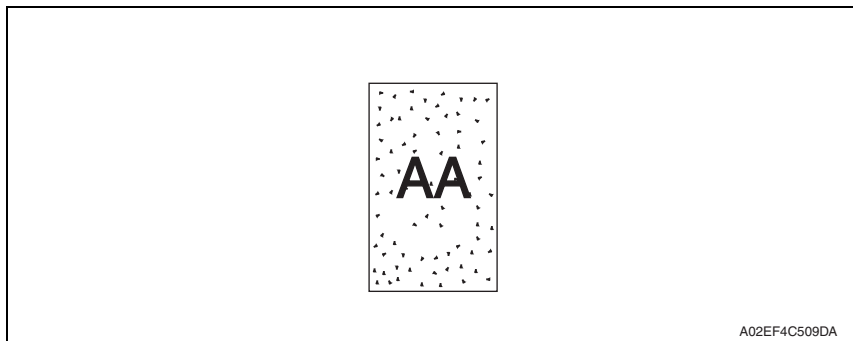

#### B. Troubleshooting procedure

Step	Section	Check item	Result	Action
1	Original	Original is damaged or dirty.	YES	Change original.
2	ADF	Original pad is dirty.	YES	Clean.
3	Original glass	Original glass is dirty.	YES	Wipe the surface clean with a soft cloth.
4		The problem has been eliminated through the checks of steps up to 3.	NO	Change scanner assy. Change CCD unit.

**18.3.4 Scanner system: fog**

**A. Typical faulty images**

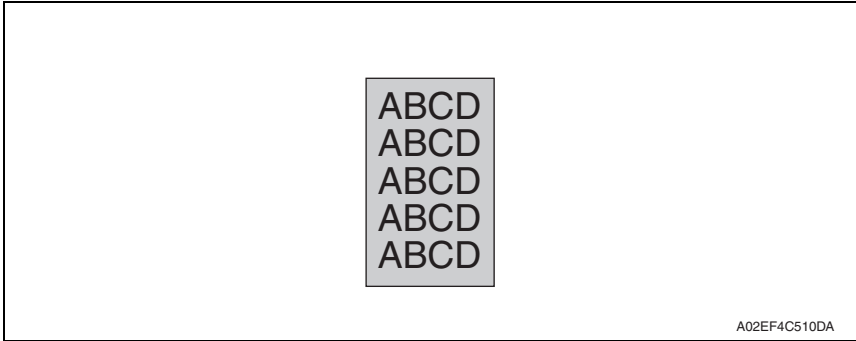

**B. Troubleshooting procedure**

Step	Section	Check item	Result	Action
1	Original	Original is damaged or dirty.	YES	Change original.
2	ADF	Original pad is dirty.	YES	Clean.
3		ADF does not lie flat.	YES	Change ADF if it is deformed or hinges are broken.
4	Original glass	Original glass is dirty.	YES	Wipe the surface clean with a soft cloth.
5	Shading sheet	Shading sheet is dirty.	YES	Wipe the surface clean with a soft cloth.
6	Mirror, lens, exposure lamp, and reflectors	Mirror is dirty.	YES	Clean.
7		Lens is dirty.	YES	Clean.
8		Exposure lamp is dirty.	YES	Clean.
9		Reflectors are dirty.	YES	Clean.
10	Basic screen Quality/Density	The problem is eliminated when the image is produced in the manual exposure setting.	NO	Try another exposure level in manual.
11		The problem has been eliminated through the checks of steps up to 10.	NO	Change scanner assy. Change CCD unit.

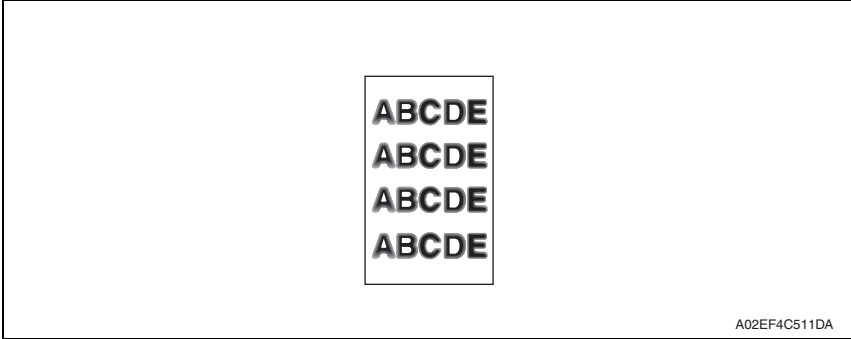

**18.3.5 Scanner system: blurred image, blotchy image****A. Typical faulty images****B. Troubleshooting procedure**

Step	Section	Check item	Result	Action
1	Original	Original does not lie flat.	YES	Change original.
2	ADF	ADF does not lie flat.	YES	Change ADF if it is deformed or hinges are broken.
3	Original glass	Original glass tilts.	YES	Position original glass correctly. Check original loading position.
4	2nd/3rd mirrors carriage	Scanner is not aligned with the 2nd/3rd mirrors carriage.	YES	Perform "Focus Positioning of the scanner and 2nd/3rd mirrors carriage" and "Scanner Position Adjustment."
5		The problem has been eliminated through the checks of steps up to 4.	NO	Change scanner assy. Change CCD unit.

**18.3.6 Scanner system: incorrect color image registration, sync shift (lines in main scan direction)**

**A. Typical faulty images**

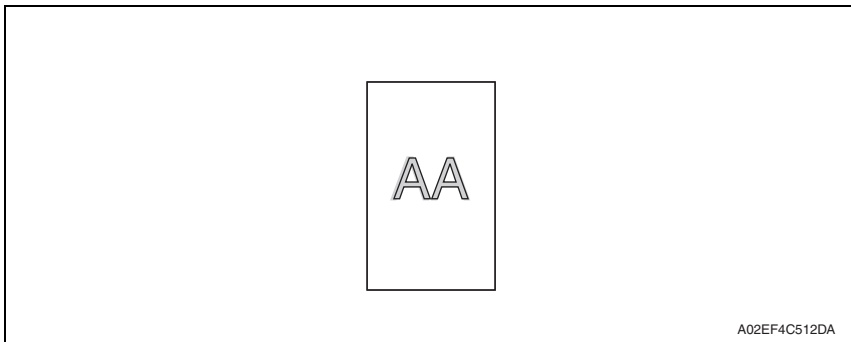

**B. Troubleshooting procedure**

Step	Section	Check item	Result	Action
1	Original	Original does not lie flat.	YES	Change original.
2	ADF	ADF does not lie flat.	YES	Change ADF if it is deformed or hinges are broken.
3	Scanner rails	Foreign matter on rails.	YES	Clean and apply lubricant.
4	Drive cables	Cable kinks or is damaged.	YES	Correct or change.
5	Scanner assy	Scanner moves smoothly.	NO	Adjust the scanner motor timing belt. → Change bushing. → Change scanner motor. → Change scanner relay board.
6		The problem has been eliminated through the checks of steps up to 5.	NO	Change CCD unit.

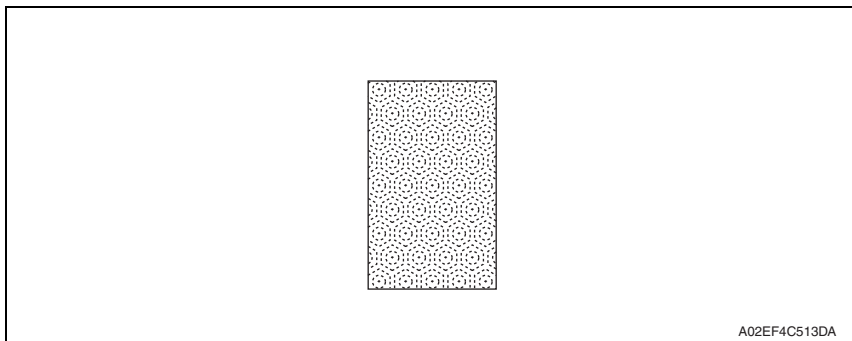
**18.3.7 Scanner system: moire****A. Typical faulty images****B. Troubleshooting procedure**

Step	Section	Check item	Result	Action
1	Original	Moire distortions recur even after the orientation of original has been changed.	NO	Change the original mode (select one other than that resulted in moire).
2	Basic screen Quality/Density	Moire distortions recur even after the original mode has been changed.	YES	Select "Text Mode" or "Photo Mode".
3	Basic screen zoom	The problem has been eliminated through the checks of steps up to 2.	NO	Change the zoom ratio.

**18.3.8 Scanner system: skewed image**

**A. Typical faulty images**

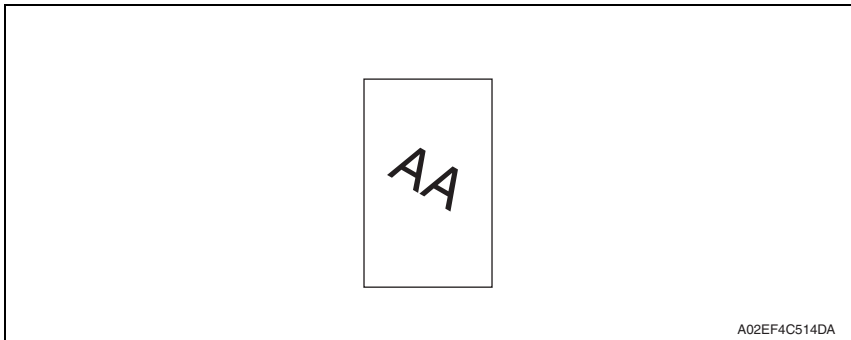

**B. Troubleshooting procedure**

Step	Section	Check item	Result	Action
1	Original	Original is skew.	YES	Reposition original.
2	Original glass	Original glass is in positive contact with the flat spring without being tilt.	NO	Reinstall the glass. Check the original loading position.
3	2nd/3rd mirrors carriage	Scanner assy is not properly aligned with 2nd/3rd mirrors carriage.	YES	Perform "Focus Positioning of the scanner and 2nd/3rd mirrors carriage" and "Scanner Position Adjustment."
4		The problem has been eliminated through the checks of steps up to 3.	NO	Change scanner assy. Change CCD unit.

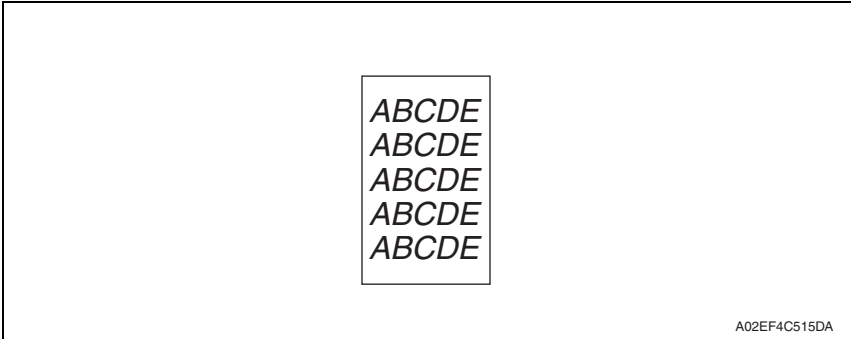
**18.3.9 Scanner system: distorted image****A. Typical faulty images****B. Troubleshooting procedure**

Step	Section	Check item	Result	Action
1	Installation	Machine is installed on a level surface.	NO	Reinstall.
2	2nd/3rd mirrors carriage	Scanner assy is not properly aligned with 2nd/3rd mirrors carriage.	YES	Perform "Focus positioning of the scanner and 2nd/3rd mirrors carriage" and "Scanner Position Adjustment."
3		The problem has been eliminated through the checks of steps up to 2.	NO	Change scanner assy. Change CCD unit.

**18.3.10 Scanner system: low image density, rough image**

**A. Typical faulty images**



**B. Troubleshooting procedure**

Step	Section	Check item	Result	Action
1	Original glass	Original glass is dirty.	YES	Wipe the surface clean with a soft cloth.
2	Shading sheet	Shading sheet is dirty.	YES	Wipe the surface clean with a soft cloth.
3	Mirror, lens, exposure lamp, and reflectors	Mirror is dirty.	YES	Clean.
4		Lens is dirty.	YES	Clean.
5		Exposure lamp is dirty.	YES	Clean.
6		Reflectors are dirty.	YES	Clean.
7		The problem has been eliminated through the checks of steps up to 6.	NO	Clean exposure lamp. → Change scanner assy. → Change CCD unit.

**18.3.11 Scanner system: defective ACS**

**A. Typical faulty images**

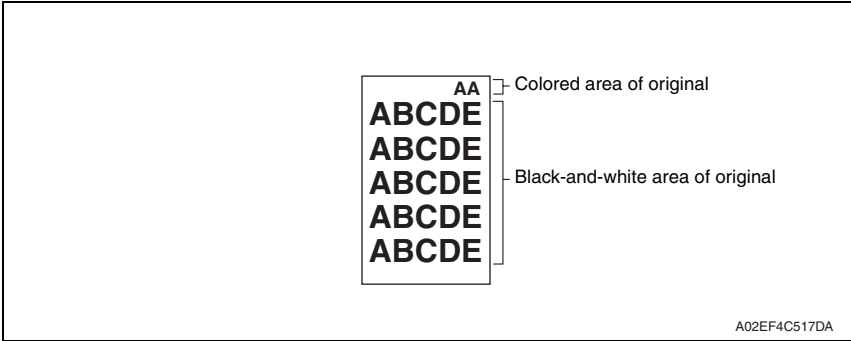

**B. Troubleshooting procedure**

Step	Section	Check item	Result	Action
1	Auto Color Level Adjustment [User Setting]	The problem persists even after the ACS determination level adjust function has been changed.	YES	Change the original loading direction. Make manual settings according to the type of original. (If the original contains a colored area in one of its corners, the machine may fail to properly detect the colored area.)

**18.3.12 Scanner system: blank copy, black copy**

**A. Typical faulty images**

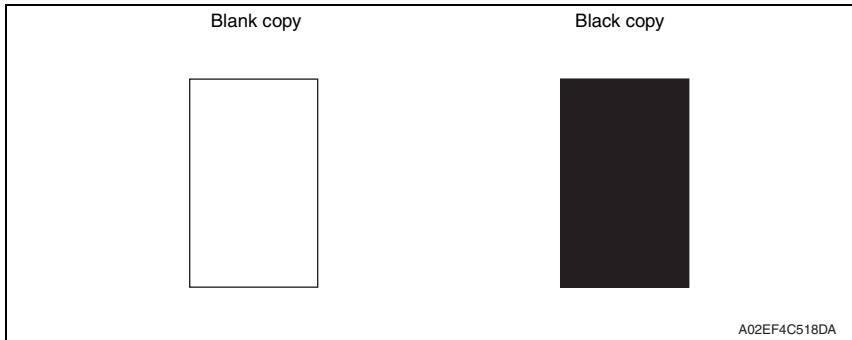

**B. Troubleshooting procedure**

Step	Section	Check item	Result	Action
1	Cable connecting scanner and printer	Connector is connected properly with no pins bent.	NO	Reconnect.
2	Image processing board (IPB)	Connectors on the image processing board are connected properly.	NO	Reconnect.
3	CCD Unit	Connectors of the CCD unit are connected properly.	NO	Reconnect.
4	Test Mode [Service Mode]	The problem is eliminated as checked with the image on a test pattern produced.	NO	Change I/F connection cable.
5	Image processing board (IPB)	The problem is eliminated after the I/F connection cable has been changed.	NO	Change image processing board.



**18.3.13 Scanner system: abnormal image**

**A. Typical faulty images**

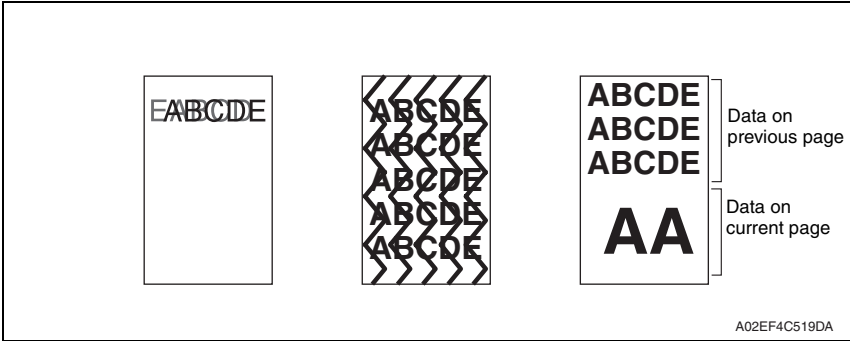

**B. Troubleshooting procedure**

Step	Section	Check item	Result	Action
1	Cable connecting scanner and printer	Connector is connected properly with no pins bent.	NO	Reconnect.
2	Image processing board (IPB)	Connectors on the image processing board are connected properly.	NO	Reconnect.
3	MFP board (MFPB)	Data on previous page is mixed with data on current page.	NO	Reinstall the memory.
4	Test Mode [Service Mode]	The problem is eliminated as checked with the image on a test pattern produced.	NO	Change interface connection cable.
5	Image processing board (IPB)	The problem is eliminated after the interface connection cable has been changed.	NO	Change image processing board.
6	Printer control board (PRCB) PH relay board (REYB/PH)	Check the connection of connectors, harness, and flat cables between PRCB and REYB/PH, and correct if necessary.	NO	Change printer control board. Change PH relay board.
7	MFP board (MFPB)	The problem has been eliminated through the checks of steps up to 6.	NO	Change MFP board.

**18.3.14 Scanner system: uneven density**

**A. Typical faulty images**

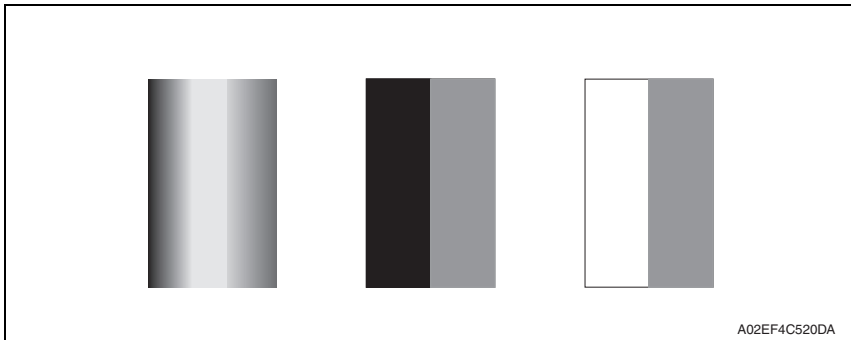

**B. Troubleshooting procedure**

**(1) When the original glass is used**

Step	Section	Check item	Result	Action
1	2nd/3rd mirrors carriage	Scanner assy is not properly aligned with 2nd/3rd mirrors carriage.	YES	Perform "Focus positioning of the scanner and 2nd/3rd mirrors carriage" and "Scanner Position Adjustment."
2	Scanner motor	Scanner motor turns smoothly.	NO	Change belt. Change scanner motor.
3		The problem has been eliminated through the checks of steps up to 2.	NO	Change scanner assy. Change CCD unit.

**(2) When the ADF is used**

Step	Section	Check item	Result	Action
1	ADF read position	The uneven density occurs when reading the original from ADF.	YES	Readjust.
2	Guide support for the original glass moving unit	Guide support is tilted.	YES	Readjust.
3	Original glass moving unit	The original glass moving unit is tilted.	YES	Readjust.

### 18.3.15 Printer monicolor: white lines in sub scan direction, white bands in sub scan direction, colored lines colored bands in sub scan direction

#### A. Typical faulty images

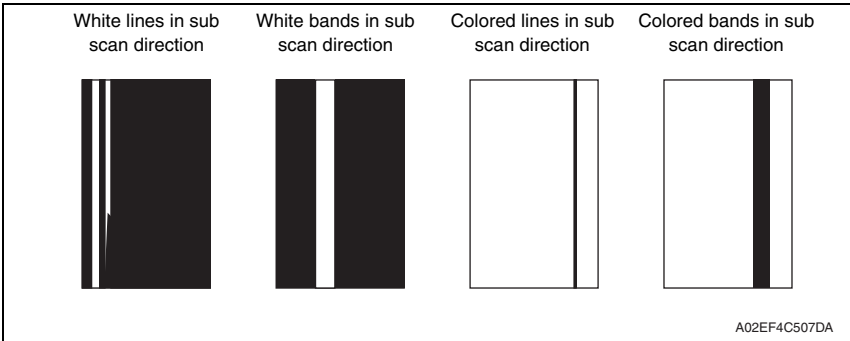

#### B. Troubleshooting procedure

Step	Section	Check item	Result	Action
1	Image check	A white line or black line in sub scan direction is sharp.	YES	Clean the electrostatic charger wire.
2		When printing thick paper, black lines appear.	YES	Select [Service Mode] → [Machine] → [Thick Paper Mode] and set [Image Quality].
3	Imaging unit	The surface of the PC drum is scratched.	YES	Change imaging unit.
4		Dirty on the outside.	YES	Clean.
5		Contact terminals make good connection between each IU and machine.	NO	Clean contact terminals.
6		Developing bias contact terminal makes good connection.	NO	Clean contact terminal and check terminal position.
7	PH unit	The surface of the PH window is dirty.	YES	Clean with cleaning jig.
8		The problem has been eliminated through the checks of steps up to 7.	NO	Change imaging unit. → Change transfer belt unit. → Change PH unit.

**18.3.16 Printer monochrome: white lines in main scan direction, white bands in main scan direction, colored lines in main scan direction, colored bands in main scan direction**

**A. Typical faulty images**

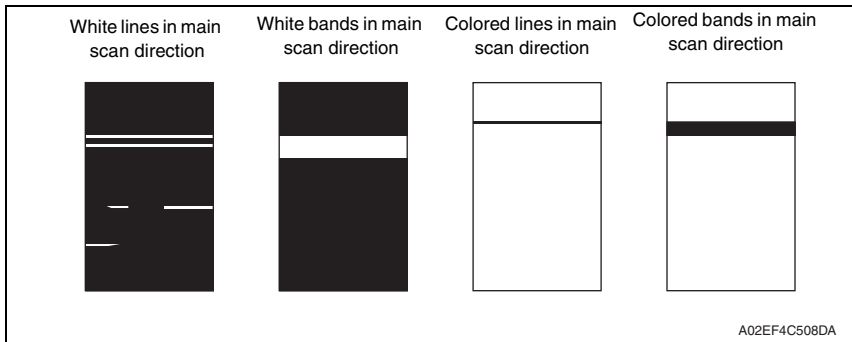

**B. Troubleshooting procedure**

Step	Section	Check item	Result	Action
1	Image check	A white line or black line in main scan direction is sharp.	NO	Clean the electrostatic charger wire.
2	Imaging unit	The surface of the PC drum is scratched.	YES	Change imaging unit.
3		Dirty on the outside.	YES	Clean.
4		Contact terminals make good connection between each IU and machine.	NO	Clean contact terminals.
5		Developing bias contact terminal makes good connection.	NO	Clean contact terminal and check terminal position.
6	PH unit	The surface of the PH window is dirty.	YES	Clean with cleaning jig.
7		The problem has been eliminated through the checks of steps up to 6.	NO	Change imaging unit. → Change transfer belt unit. → Change PH unit.

### 18.3.17 Printer monicolor: uneven density in sub scan direction

#### A. Typical faulty images

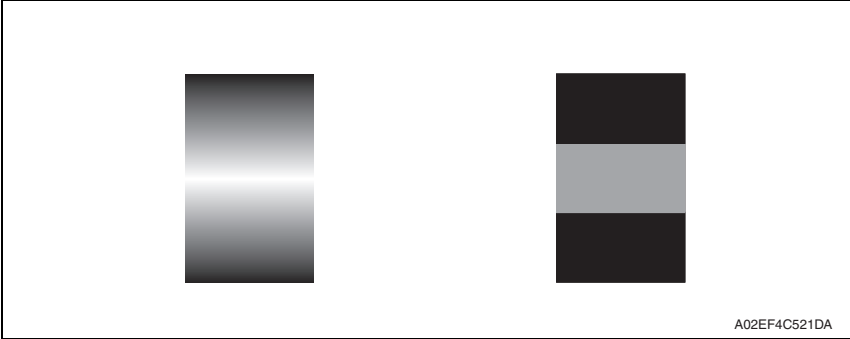

#### B. Troubleshooting procedure

Step	Section	Check item	Result	Action
1	High image density original	Uneven density in sub scan direction occurs at a pitch of 40 mm to 50 mm when a multi-copy cycle is run using an original with high image density (50% or more).	YES	Feed 10 to 20 blank sheets of paper with no originals placed, as the IU fails to keep up with a high demand for toner.
2	Machine → LD adjustment → LD lightness balance adjust. (Service Mode)	The problem has been eliminated through the LD lightness balance adjust.	NO	Go to next step.
3	Imaging unit	The surface of the PC drum is scratched.	YES	Change imaging unit.
4		Dirty on the outside.	YES	Clean.
5	PH unit	The surface of the PH window is dirty.	YES	Clean with cleaning jig.
6	Image transfer belt unit	Is abnormality found in the cam gear?	YES	Change transfer belt unit.
7		The problem has been eliminated through the checks of steps up to 6.	NO	Change IU. → Change PH unit. → Change printer control board → Change High voltage unit.

**18.3.18 Printer monochrome: uneven density in main scan direction**

**A. Typical faulty images**

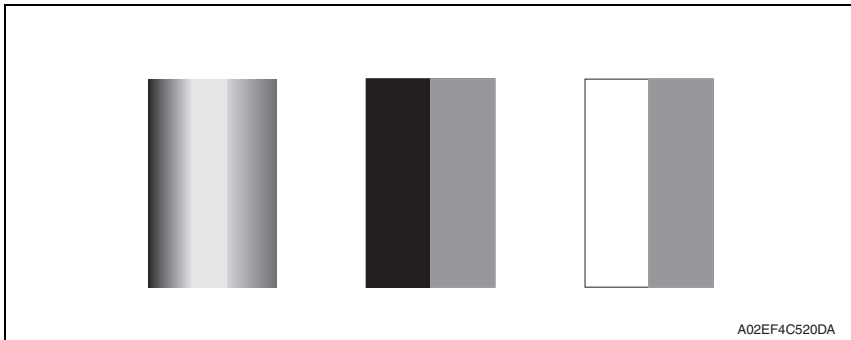

**B. Troubleshooting procedure**

Step	Section	Check item	Result	Action
1	Machine → LD adjustment → LD lightness balance adjust. (Service Mode)	The problem has been eliminated through the LD lightness balance adjust.	NO	Go to next step.
2	Imaging unit	The surface of the PC drum is scratched.	YES	Change imaging unit.
3		Dirty on the outside.	YES	Clean.
4	PH unit	The surface of the PH window is dirty.	YES	Clean with cleaning jig.
5	Transfer roller	Check that the spring does not come off during the pressure operation of the transfer roller.	NO	Correct. Change transfer roller unit.
6	Transfer belt unit	Transfer belt unit makes positive contact with plates on rails.	NO	Check and correct contacts.
7		Is abnormality found in the cam gear?	YES	Change transfer belt unit.
8		The problem has been eliminated through the checks of steps up to 6.	NO	Change imaging unit. → Change PH unit. → Change high voltage unit.

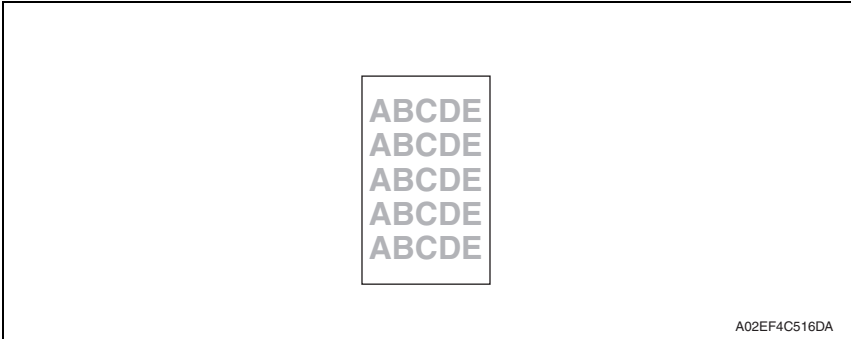
**18.3.19 Printer monochrome: low image density****A. Typical faulty images**

A02EF4C516DA

**B. Troubleshooting procedure**

Step	Section	Check item	Result	Action
1	Warning display	The maintenance call mark is displayed on the panel.	YES	Take action according to the warning code shown on the state confirm screen.
2	State Confirmation → Table Number (Service Mode)	Check data for Vg and Vdc. Color Vdc: around 400 V Vg : around 500 V Black Vdc: around 400 V Vg : around 500 V	—	Go to next step.
3	State Confirmation → Level History 1 (Service Mode)	Check TCR data. (specified rang: 6 to 8 %)	NO	Go to next step.
4		IDC output value is around 4.3 V.	NO	Clean IDC sensor and execute the image stabilization. Check image transfer belt for damage and correct as necessary.
5	Level history data check results	Low TCR and low Vg and Vdc	YES	Go to step 10.
6		Low TCR and high Vg and Vdc	YES	Go to step 14.
7		TCR falling within specified range and low Vg and Vdc	YES	Go to step 10.
8		TCR falling within specified range and high Vg and Vdc	YES	Go to step 14.
9		The situations other than the above-mentioned.	YES	Go to step 10.
10	Imaging unit	Dirty on the outside.	YES	Clean.
11	PH unit	The surface of the PH window is dirty.	YES	Clean with cleaning jig.
12	Transfer belt unit	Transfer belt unit makes positive contact with plates on rails.	NO	Check and correct contacts.
13		Is abnormality found in the cam gear?	YES	Change transfer belt unit.

Step	Section	Check item	Result	Action
14	Hopper unit	Connectors are loose.	YES	Reconnect.
15		Gear is cracked.	YES	Change gear.
16	Image Process Adjustment → TCR Toner Supply (Service Mode)	Toner is properly supplied when TCR toner supply is run.	NO	Go to next step.
17	Image Process Adjustment → Gradation Adjust (Service Mode)	“Conv. Value” falls within the specified range as checked through gradation adjust. Dark: $0 \pm 100$ Highlight: $0 \pm 60$	YES	Go to step 20.
18	Image Process Adjustment → D Max Density (Service Mode)	The problem has been eliminated through the adjust of D Max.	NO	Go to next step.
19	Image Process Adjustment → Stabilizer → Initialize + Image Stabilization (Service Mode)	After the Initialize + Image Stabilization sequence has been completed, run gradation adjust.	NO	Go to next step.
20		The problem has been eliminated through the checks of steps up to 19.	NO	Change imaging unit. → Change printer control board → Change PH unit. → Change high voltage unit.

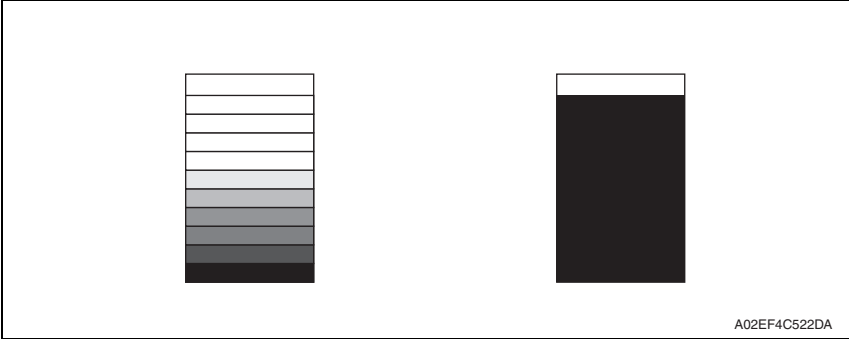

**18.3.20 Printer monicolor: gradation reproduction failure****A. Typical faulty images****B. Troubleshooting procedure**

Step	Section	Check item	Result	Action
1	Warning display	The maintenance call mark is displayed on the panel.	YES	Take action according to the warning code shown on the state confirm screen.
2	Photo/density	Original type and screen pattern are selected properly.	NO	Change screen pattern.
3	Imaging unit	Dirty on the outside.	YES	Clean.
4	PH unit	The surface of the PH window is dirty.	YES	Clean with cleaning jig.
5	State Confirmation → Level History 1 (Service Mode)	IDC output value is around 4.3 V.	NO	Clean IDC sensor and execute the image stabilization. Check transfer belt for damage and correct as necessary.
6	Image Process Adjustment → Gradation Adjust (Service Mode)	"Conv. Value" falls within the specified range as checked through gradation adjust. Dark: $0 \pm 100$ Highlight: $0 \pm 60$	YES	Go to step 9.
7	Image Process Adjustment → D Max Density (Service Mode)	The problem has been eliminated through the adjust of D Max.	NO	Go to next step.
8	Image Process Adjustment → Stabilizer → Initialize + Image Stabilization (Service Mode)	After the Initialize + Image Stabilization sequence has been completed, run gradation adjust;	NO	Go to next step.
9		The problem has been eliminated through the checks of steps up to 8.	NO	Change imaging unit. → Change printer control board → Change PH unit. → Change high voltage unit.

**18.3.21 Printer monochrome: foggy background**

**A. Typical faulty images**

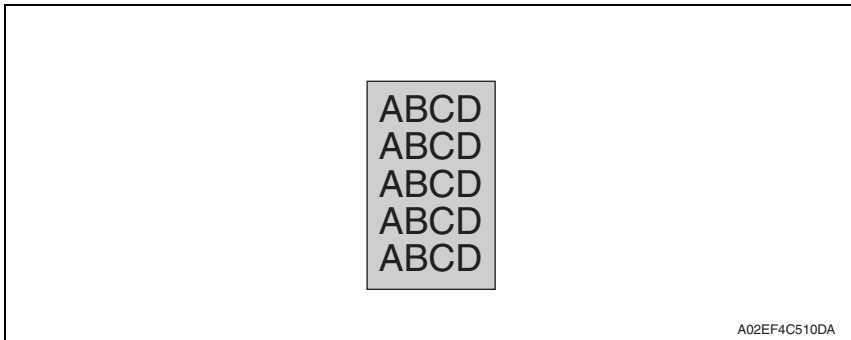

**B. Troubleshooting procedure**

Step	Section	Check item	Result	Action
1	Warning display	The maintenance call mark is displayed on the panel.	YES	Take action according to the warning code shown on the state confirm screen.
2	State Confirmation → Table Number (Service Mode)	Check data for Vg and Vdc. Color Vdc: around 400 V Vg : around 500 V Black Vdc: around 400 V Vg : around 500 V	NO	Go to next step.
3	State Confirmation → Level History 1 (Service Mode)	Check TCR data. (specified rang: 6 to 8 %)	NO	Go to next step.
4		IDC output value is around 4.3 V.	NO	Clean IDC sensor and execute the image stabilization. Check transfer belt for damage and correct as necessary.
5	Level history data check results	Low TCR and low Vg and Vdc	YES	Go to step 10.
6		Low TCR and high Vg and Vdc	YES	Go to step 12.
7		TCR falling within specified range and low Vg and Vdc	YES	Go to step 10.
8		TCR falling within specified range and high Vg and Vdc	YES	Go to step 12.
9		The situations other than the above-mentioned.	YES	Go to step 10.
10	Imaging unit	Dirty on the outside.	YES	Clean.
11	PH unit	The surface of the PH window is dirty.	YES	Clean with cleaning jig.
12	Image Process Adjustment → Background Voltage Margin (Service Mode)	The problem is eliminated after background voltage margin has been adjusted.	NO	Go to next step.

Step	Section	Check item	Result	Action
13	Image Process Adjustment → Gradation Adjust (Service Mode)	"Conv. Value" falls within the specified range as checked through gradation adjust. Dark: $0 \pm 100$ Highlight: $0 \pm 60$	YES	Go to step 17.
14	Image Process Adjustment → D Max Density (Service Mode)	The problem has been eliminated through the adjust of D Max.	NO	Go to next step.
15	Image Process Adjustment → Stabilizer → Initialize + Image Stabilization (Service Mode)	After the Initialize + Image Stabilization sequence has been completed, run gradation adjust.	NO	Go to next step.
16	Printer control board (PRCB) PH relay board (REYB/PH)	Check the connection of connectors, harness, and flat cables between PRCB and REYB/PH, and correct if necessary.	NO	Change printer control board. Change PH relay board.
17		The problem has been eliminated through the checks of steps up to 16.	NO	Change imaging unit. → Change PH unit. → Change high voltage unit.

**18.3.22 Printer monochrome: void areas, white spots**

**A. Typical faulty images**

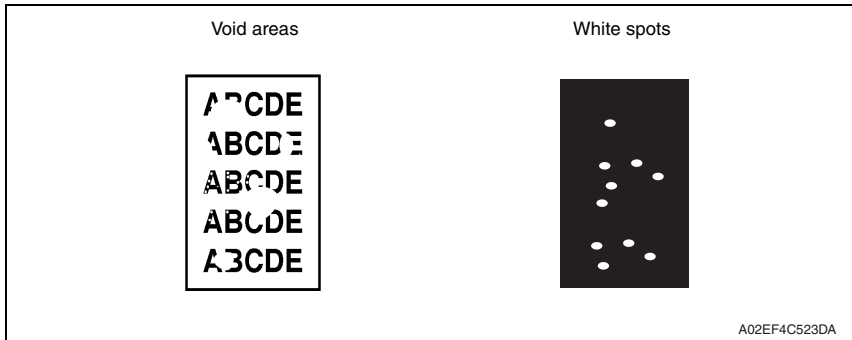

**B. Troubleshooting procedure**

Step	Section	Check item	Result	Action
1	Image check	There are void areas at the front side or high density section.	YES	<a href="#">See P.578</a>
2		There is void area at the rear side section.	YES	Perform [Transfer Adjust] of [Image Process Adjustment] under Service Mode.
3	Imaging unit	The surface of the PC drum is scratched.	YES	Change imaging unit.
4		Dirty on the outside.	YES	Clean.
5	Toner cartridge	Foreign matter or caked toner in the toner cartridge.	YES	Remove foreign matter.
6	Installation environment	Is the atmospheric pressure at the installation site low?	YES	Make the following adjustment: [Service Mode] → [Image Process Adjustment] → [Dev. Bias Choice].

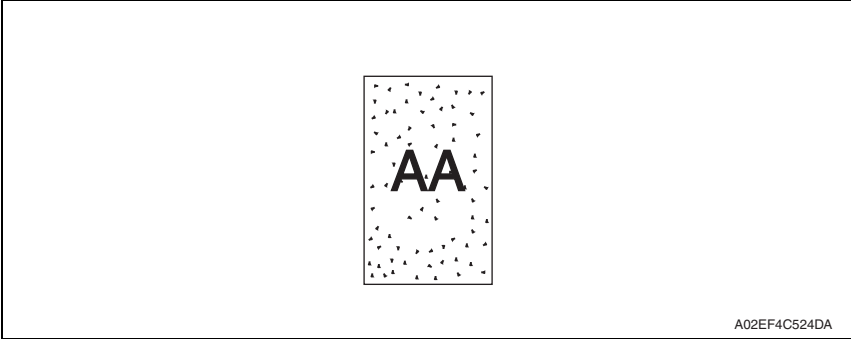
**18.3.23 Printer monochrome: colored spots****A. Typical faulty images****B. Troubleshooting procedure**

Step	Section	Check item	Result	Action
1	Imaging unit	Developing bias contact terminal makes good connection.	NO	Clean contact terminal and check terminal position.
2		The surface of the PC drum is scratched.	YES	Change imaging unit.
3		Dirty on the outside.	YES	Clean.

**18.3.24 Printer monochrome: blurred image**

**A. Typical faulty images**

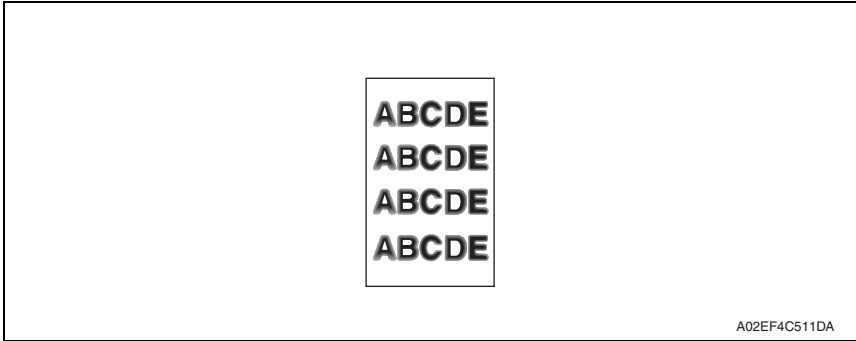

**B. Troubleshooting procedure**

Step	Section	Check item	Result	Action
1	PH unit	The surface of the PH window is dirty.	YES	Clean with cleaning jig.
2	Imaging unit	Dirty on the outside.	YES	Clean.
3		The problem has been eliminated through the checks of steps up to 2.	NO	Change imaging unit. → Change PH unit.

### 18.3.25 Printer monochrome: blank copy, black copy

#### A. Typical faulty images

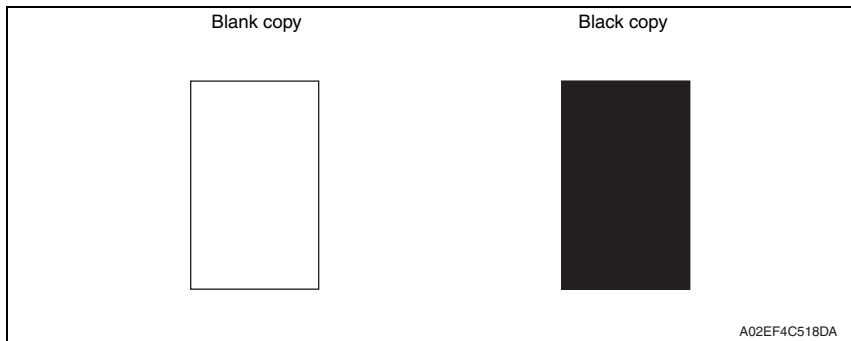

#### B. Troubleshooting procedure

Step	Section	Check item	Result	Action
1	Image check	A blank copy occurs.	YES	Check PH unit connector for proper connection.
2	Imaging unit	Coupling of IU drive mechanism is installed properly.	NO	Check and correct drive transmitting coupling. Change IU.
3		The PC drum charge corona voltage contact or PC drum ground contact of the imaging unit is connected properly.	NO	Check, clean, or correct the contact.
4	High voltage unit	Connector is connected properly.	NO	Reconnect.
5		The problem has been eliminated through the check of step 4.	NO	Change high voltage unit. → Change printer control board → Change PH unit.

**18.3.26 Printer monochrome: uneven image**

**A. Typical faulty images**

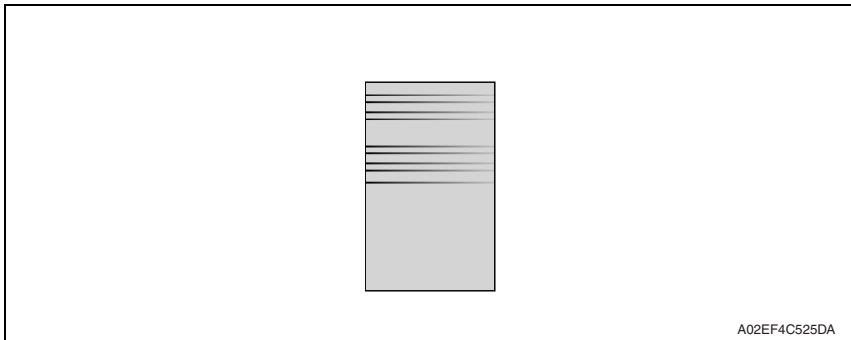

**B. Troubleshooting procedure**

Step	Section	Check item	Result	Action
1	Toner cartridge	The toner cartridge of every color is surely installed.	NO	Re-install it.
2	PH unit	The PH unit is surely installed.	NO	Re-install it.
3	Toner cartridge	There is any stain or breakage on the drive section of the toner cartridge.	YES	Clean/replace the toner cartridge.
4	Imaging unit	There is any stain, damage or abrasion on the PC drum.	YES	Replace the imaging unit.
5	Transfer roller	There is any stain, damage, deformation or abrasion on the transfer roller.	YES	Replace the transfer roller.
6	Fusing unit	There is any stain, damage, deformation or abrasion on the roller and drive section of the fusing unit.	YES	Replace the fusing unit.
7		The problem has been eliminated through the check of step 6.	NO	Replace the transfer belt unit.



**18.3.27 Printer 4-color: white lines in sub scan direction, white bands in sub scan direction, colored lines in sub scan direction, and colored bands in sub scan direction**

**A. Typical faulty images**

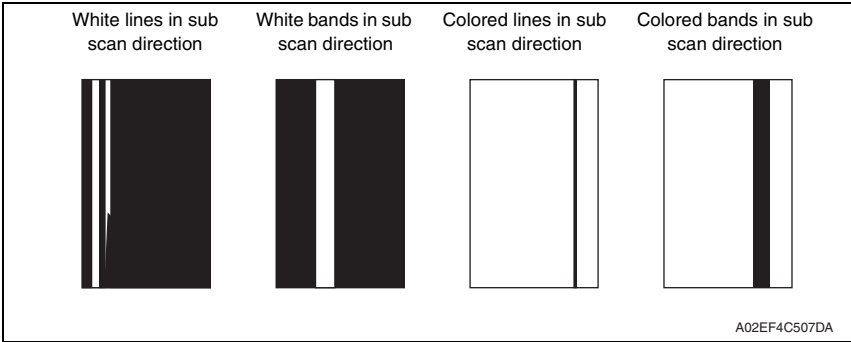

**B. Troubleshooting procedure**

Step	Section	Check item	Result	Action
1	Image check	A white line or colored line in sub scan direction.	YES	Clean the comb electrode by moving the comb electrode cleaning lever.
2	Transfer belt unit	Fingerprints, oil, or other foreign matter is evident on the transfer belt.	YES	Clean.
3		Transfer belt is dirty or scratched.	YES	Clean dirty belt with a soft cloth. Change transfer belt unit if belt is damaged.
4		Cleaning blade is not effective in removing toner completely.	YES	Clean cleaning blade. Change transfer belt unit.
5	Transfer roller unit	Transfer roller is dirty or scratched.	YES	Change transfer roller unit.
6	Paper path	There is foreign matter on paper path.	YES	Remove foreign matter.
7		Image transfer paper separator fingers are damaged or dirty.	YES	Clean or change.
8	Fusing unit	Fusing entrance guide plate is dirty or damaged.	YES	Clean. Change fusing unit.
9		Fusing paper separator fingers are dirty.	YES	Clean.
10		The problem has been eliminated through the checks of steps up to 9.	NO	Change printer control board

**18.3.28 Printer 4-color: white lines in main scan direction, white bands in main scan direction, colored lines in main scan direction, and colored bands in main scan direction**

**A. Typical faulty images**

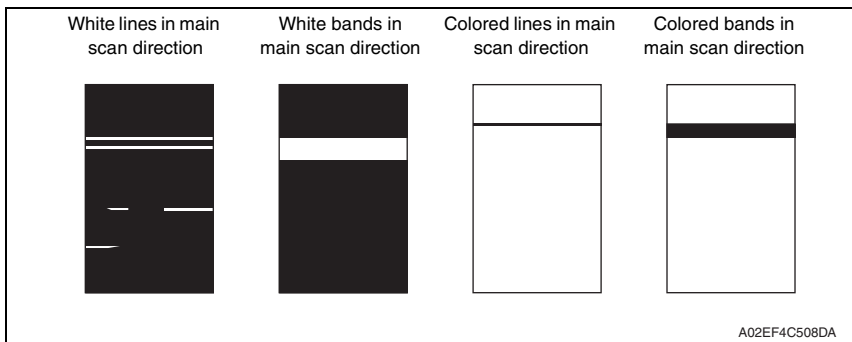

**B. Troubleshooting procedure**

Step	Section	Check item	Result	Action
1	Transfer belt unit	Fingerprints, oil, or other foreign matter is evident on the transfer belt.	YES	Clean.
2		Transfer belt is dirty or scratched.	YES	Clean dirty belt with a soft cloth. Change transfer belt unit if belt is damaged.
3	Transfer roller unit	Transfer roller is dirty or scratched.	YES	Change transfer roller unit.
4	Paper path	There is foreign matter on paper path.	YES	Remove foreign matter.
5		Image transfer paper separator fingers are damaged or dirty.	YES	Clean or change.
6	Fusing unit	Fusing entrance guide plate is dirty or damaged.	YES	Clean. Change fusing unit.
7		Fusing paper separator fingers are dirty.	YES	Clean.
8	Neutralizing brush	The resistance values between the neutralizing brush and the ground terminal is not ∞.	NO	Check the contact modify. Change neutralizing brush.
9		The problem has been eliminated through the checks of steps up to 9.	NO	Change printer control board

**18.3.29 Printer 4-color: uneven density in sub scan direction**

**A. Typical faulty images**



**B. Troubleshooting procedure**

Step	Section	Check item	Result	Action
1	Transfer belt unit	Fingerprints, oil, or other foreign matter is evident on the transfer belt.	YES	Clean.
2		Transfer belt is dirty or scratched.	YES	Clean dirty belt with a soft cloth. Change transfer belt unit if belt is damaged.
3		Terminal is dirty.	YES	Clean.
4	Transfer roller unit	Image transfer roller is installed properly.	NO	Reinstall.
5		Image transfer roller is dirty or scratched.	YES	Change transfer roller unit.
6		The problem has been eliminated through the checks of steps up to 5.	NO	Change transfer belt unit.

**18.3.30 Printer 4-color: uneven density in main scan direction**

**A. Typical faulty images**

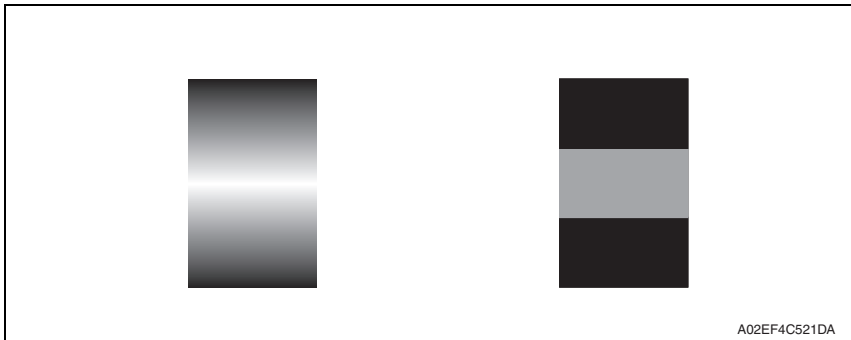

**B. Troubleshooting procedure**

Step	Section	Check item	Result	Action
1	Transfer belt unit	Fingerprints, oil, or other foreign matter is evident on the transfer belt.	YES	Clean.
2		Transfer belt is dirty or scratched.	YES	Clean dirty belt with a soft cloth. Change transfer belt unit if belt is damaged.
3		Terminal is dirty.	YES	Clean.
4	Transfer roller unit	Image transfer roller is installed properly.	NO	Reinstall.
5		Image transfer roller is dirty or scratched.	YES	Change transfer roller unit.
6		The problem has been eliminated through the checks of steps up to 5.	NO	Change transfer belt unit. → Change high voltage unit.

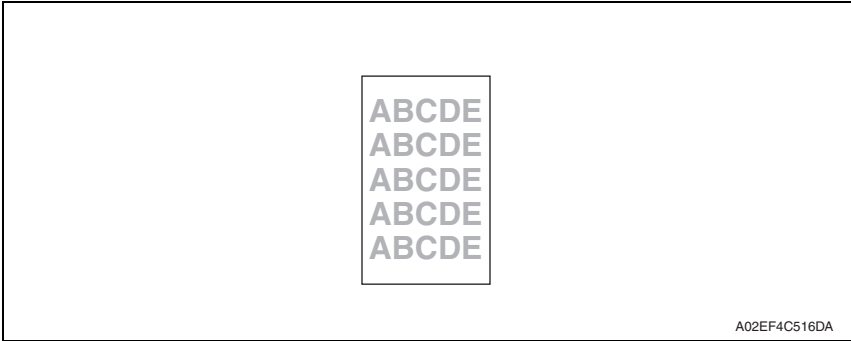
**18.3.31 Printer 4-color: low image density****A. Typical faulty images****B. Troubleshooting procedure**

Step	Section	Check item	Result	Action
1	Paper	Paper is damp.	YES	Change paper to one just unwrapped from its package.
2	Transfer belt unit	Terminal is dirty.	YES	Clean.
3	Transfer roller unit	Transfer roller is installed properly.	NO	Reinstall.
4		Transfer roller is dirty or scratched.	NO	Change transfer roller unit.
5	IDC sensor	Sensor is dirty.	YES	Clean IDC sensor and execute the image stabilization.
6	Image Process Adjustment → Gradation Adjust (Service Mode)	"Conv. Value" falls within the specified range as checked through gradation adjust. Dark: $0 \pm 100$ Highlight: $0 \pm 60$	YES	Go to step 9.
7	Image Process Adjustment → D Max Density (Service Mode)	The problem has been eliminated through the adjust of D Max Density.	NO	Go to next step.
8	Image Process Adjustment → Stabilizer → Initialize + Image Stabilization (Service Mode)	After the Initialize + Image Stabilization sequence has been completed, run gradation adjust.	NO	Go to next step.
9		The problem has been eliminated through the checks of steps up to 8.	NO	Change image transfer belt unit. → Change printer control board → Change high voltage unit.

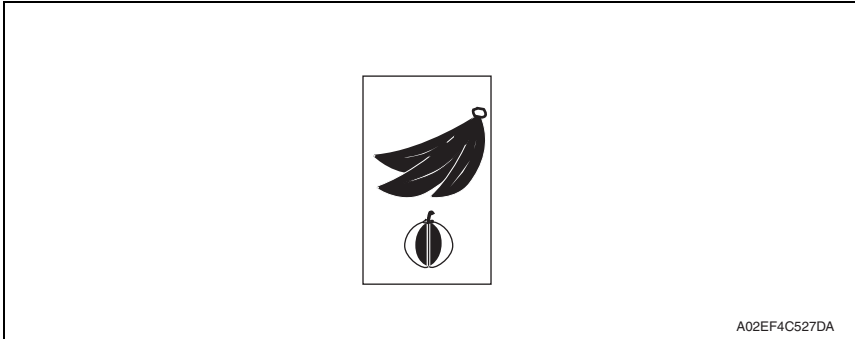
**18.3.32 Printer 4-color: poor color reproduction****A. Typical faulty images****B. Troubleshooting procedure**

Step	Section	Check item	Result	Action
1	Paper	Paper is damp.	YES	Change paper to one just unwrapped from its package.
2	Transfer belt unit	Terminal is dirty.	YES	Clean.
3	Transfer roller unit	Transfer roller is installed properly.	NO	Reinstall.
4		Transfer roller is dirty or scratched.	NO	Change transfer roller unit.
5	IDC sensor	Sensor is dirty.	YES	Clean IDC sensor and execute the image stabilization.
6	Image Process Adjustment → Gradation Adjust (Service Mode)	"Conv. Value" falls within the specified range as checked through gradation adjust. Dark: $0 \pm 100$ Highlight: $0 \pm 60$	YES	Go to step 9.
7	Image Process Adjustment → D Max Density (Service Mode)	The problem has been eliminated through the adjust of D Max Density.	NO	Go to next step.
8	Image Process Adjustment → Stabilizer → Initialize + Image Stabilization (Service Mode)	After the Initialize + Image Stabilization sequence has been completed, run gradation adjust.	NO	Go to next step.
9		The problem has been eliminated through the checks of steps up to 8.	NO	Change image transfer belt unit. → Change printer control board → Change high voltage unit.

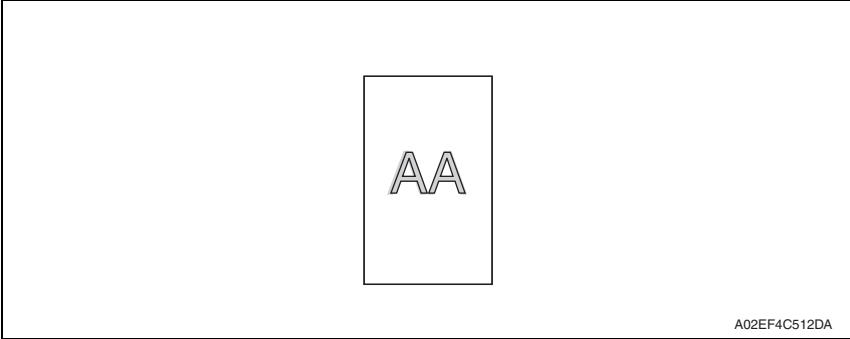
**18.3.33 Printer 4-color: incorrect color image registration****A. Typical faulty images****B. Troubleshooting procedure**

Step	Section	Check item	Result	Action
1	Warning display	The maintenance call mark is displayed on the panel.	YES	Take action according to the warning code shown on the state confirm screen.
2	Machine condition	Vibration is given to the machine after main power switch has been turned ON.	YES	Turn off the main power switch and turn it on again more than 10 seconds after.
3	Transfer belt unit	Fingerprints, oil, or other foreign matter is evident on the transfer belt.	YES	Clean.
4		Transfer belt is dirty or scratched.	YES	Clean dirty belt with a soft cloth. Change transfer belt unit if belt is damaged.
5		Drive coupling to the machine is dirty.	YES	Clean.
6	Imaging unit	The surface of the PC drum is scratched.	YES	Change imaging unit.
7	Transfer roller unit	Transfer roller is installed properly.	NO	Reinstall.
8		Transfer roller is dirty or scratched.	YES	Change transfer roller unit.
9	Machine → Fusing Transport Speed (Service Mode)	Brush effect or blurred image occurs.	YES	Readjust fusing transport speed.
10	Machine → Color registration Adjustment (Service Mode)	Check the specific color in which color shift occurs.	YES	Perform "Color registration Adjustment." If color shift is not corrected even with a correction of $\pm 1$ dot, go to next step.
11		The problem has been eliminated through the checks of steps up to 10.	NO	Change transfer belt unit. → Change printer control board

**18.3.34 Printer 4-color: void areas, white spots**

**A. Typical faulty images**

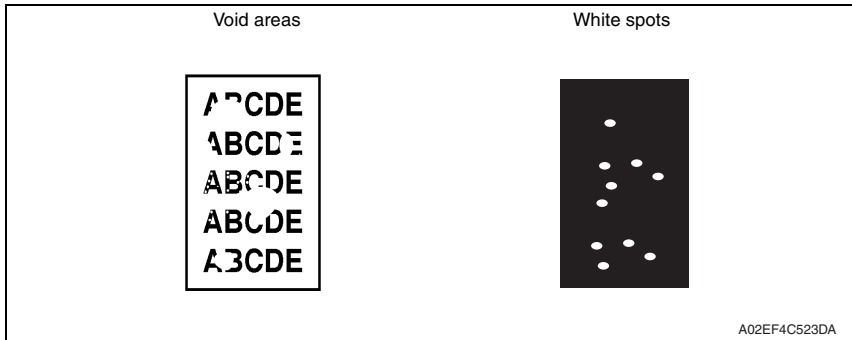

**B. Troubleshooting procedure**

Step	Section	Check item	Result	Action
1	Image check	There are void areas at the front side or high density section.	YES	P.593
2		There are void areas in the trailing edge.	YES	Perform [Transfer Adjust] of [Image Process Adjustment] under Service Mode.
3	Transfer belt unit	Fingerprints, oil, or other foreign matter is evident on the transfer belt.	YES	Clean.
4		Transfer belt is dirty or scratched.	YES	Clean dirty belt with a soft cloth. Change transfer belt unit if belt is damaged.
5	Transfer roller unit	Transfer roller is dirty or scratched.	YES	Change 2nd image transfer roller unit.
6		Charge neutralizing cloth is not separated and ground terminal is connected properly.	NO	Correct or change.
7	Paper path	There is foreign matter on paper path.	YES	Remove foreign matter.
8		Pre-image transfer guide plate is damaged or dirty.	YES	Clean or change.
9		The problem has been eliminated through the checks of steps up to 8.	NO	Change transfer belt unit.



**18.3.35 Printer 4-color: colored spots**

**A. Typical faulty images**

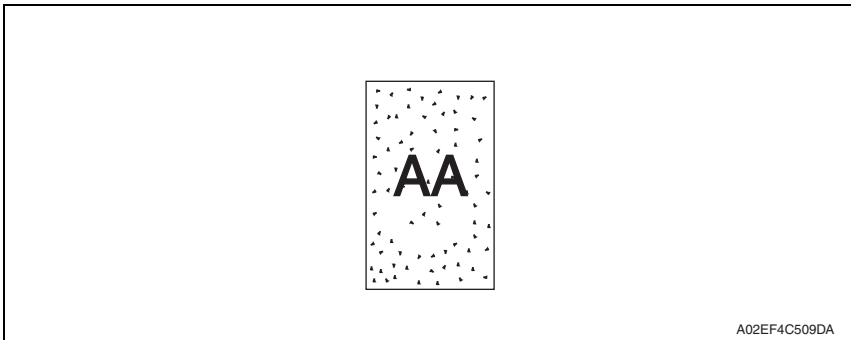

**B. Troubleshooting procedure**

Step	Section	Check item	Result	Action
1	Imaging unit	The surface of the PC drum is scratched.	YES	Change imaging unit.
2	Transfer belt unit	Fingerprints, oil, or other foreign matter is evident on the image transfer belt.	YES	Clean.
3		Transfer belt is dirty or scratched.	YES	Clean dirty belt with a soft cloth. Change transfer belt unit if belt is damaged.
4	Transfer roller unit	Transfer roller is dirty or scratched.	YES	Change transfer roller unit.
5	Paper path	There is foreign matter on paper path.	YES	Remove foreign matter.
6	Fusing unit	Fusing belt is dirty or scratched.	YES	Change fusing unit.
7		The problem has been eliminated through the checks of steps up to 6.	NO	Change transfer belt unit.

**18.3.36 Printer 4-color: poor fusing performance, offset**

**A. Typical faulty images**

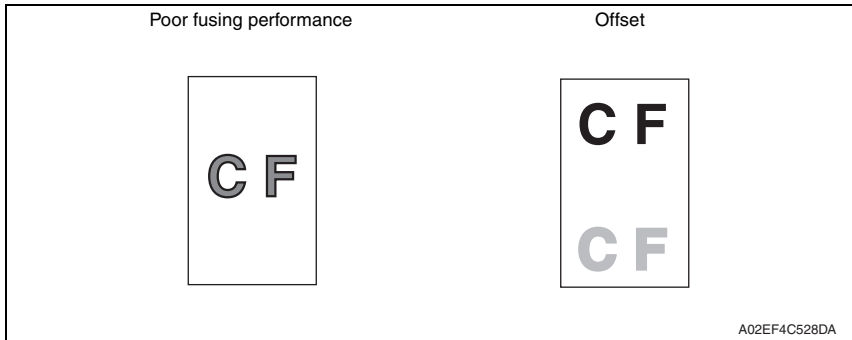

**B. Troubleshooting procedure**

Step	Section	Check item	Result	Action
1	Paper	Paper type does not match.	YES	Change the setting.
2	Machine→ Fusing Temperature (Service Mode)	Changing fusing temperature eliminates the problem of poor fusing performance and offset.	YES	Readjust fusing temperature.
3		The problem has been eliminated through the checks of steps up to 2.	NO	Change fusing unit.

**18.3.37 Printer 4-color: brush effect, blurred image**

**A. Typical faulty images**

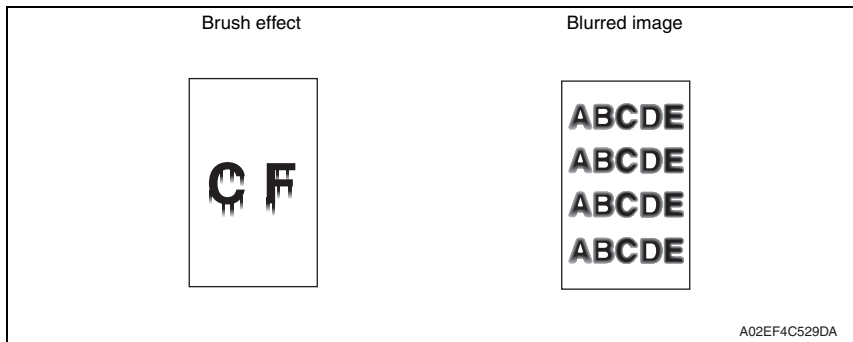

**B. Troubleshooting procedure**

Step	Section	Check item	Result	Action
1	Paper	Paper is damp.	YES	Change paper to one just unwrapped from its package.
2		Paper type does not match.	YES	Change the setting.
3	Fusing unit	Fusing unit is installed properly.	NO	Reinstall.
4		Fusing entrance guide plate is dirty.	YES	Clean.
5		Fusing belt is dirty or scratched.	YES	Change fusing unit.
6	Machine → Fusing Transport Speed (Service Mode)	Changing fusing speed eliminates the problem of brush effect and blurred image.	YES	Readjust fusing transport speed.

**18.3.38 Printer 4-color: back marking**

**A. Typical faulty images**

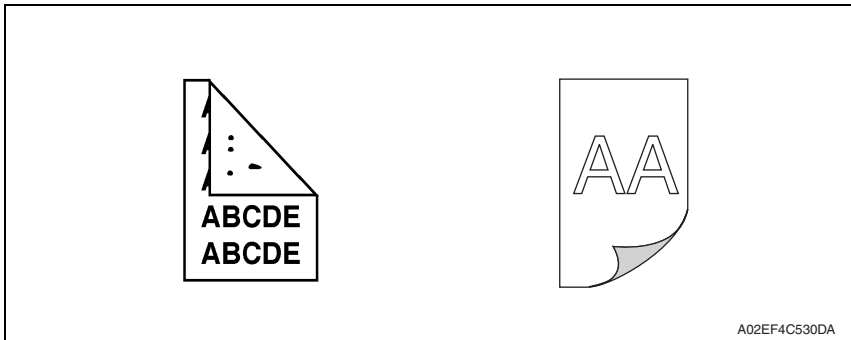

**B. Troubleshooting procedure**

Step	Section	Check item	Result	Action
1	2nd image transfer roller unit	Image transfer roller is scratched or dirty.	YES	Change transfer roller unit.
2	Paper path	There is foreign matter on paper path.	YES	Remove foreign matter.
3	Fusing unit	Fusing entrance guide plate is scratched or dirty.	YES	Clean or change.
4		Lower fusing roller is scratched or dirty.	YES	Change fusing unit.
5	Transfer belt unit	Fingerprints, oil, or other foreign matter is evident on the transfer belt.	YES	Clean.
6		The problem has been eliminated through the checks of steps up to 5.	NO	Change transfer belt unit. → Change high voltage unit.

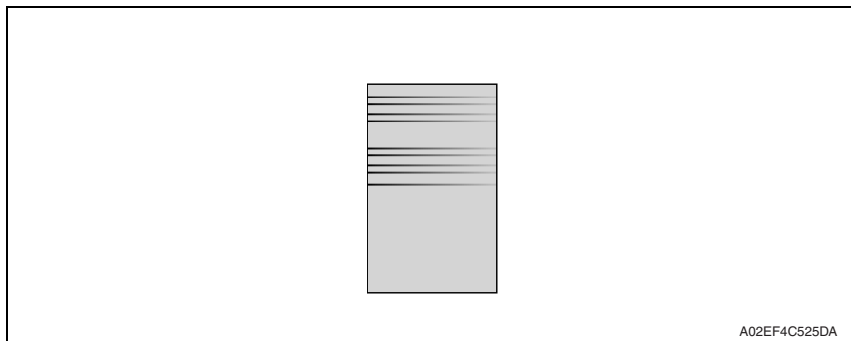
**18.3.39 Printer 4-color: uneven image****A. Typical faulty images****B. Troubleshooting procedure**

Step	Section	Check item	Result	Action
1	Toner cartridge	The toner cartridge of every color is surely installed.	NO	Re-install it.
2	PH unit	The PH unit is surely installed.	NO	Re-install it.
3	Toner cartridge	There is any stain or breakage on the drive section of the toner cartridge.	YES	Clean/replace the toner cartridge.
4	Imaging unit	There is any stain, damage or abrasion on the PC drum.	YES	Replace the imaging unit.
5	Transfer roller unit	There is any stain, damage, deformation or abrasion on the transfer roller.	YES	Replace the transfer roller unit.
6	Fusing unit	There is any stain, damage, deformation or abrasion on the roller and drive section of the fusing unit.	YES	Replace the fusing unit.
7		The problem has been eliminated through the check of step 6.	NO	Replace the transfer belt unit.

# Appendix

## 19. Parts layout drawing

### 19.1 Main body

#### 19.1.1 Scanner section

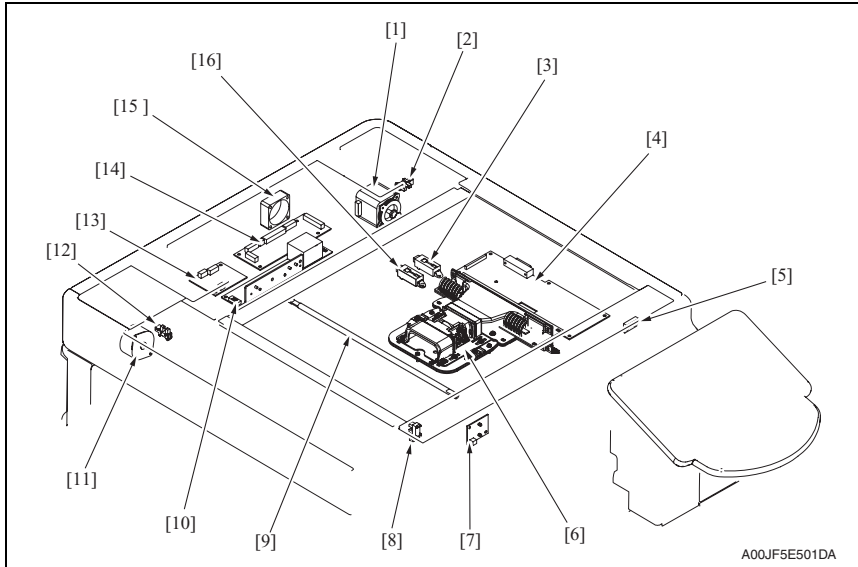

- |  |  |
|--|--|
| [1] Scanner motor (M201)                     | [9] Exposure lamp (FL201)                          |
| [2] 20 degree sensor (PS202)                 | [10] Inverter board (INVB)                         |
| [3] Original size detection sensor/1 (PS204) | [11] Original glass moving motor (M202)            |
| [4] Image processing board (IPB)             | [12] Glass home pos. sensor (PS203)                |
| [5] Original cover sensor (RS201)            | [13] Original glass position control board (OGPCB) |
| [6] CCD board (CCDB)                         | [14] Scanner relay board (REYB/SCAN)               |
| [7] Machine condition monitor board (MCMB)   | [15] Optical cooling fan motor (FM201)             |
| [8] Home sensor (PS201)                      | [16] Original size detection sensor/2 (PS205)      |

## 19.1.2 Engine section

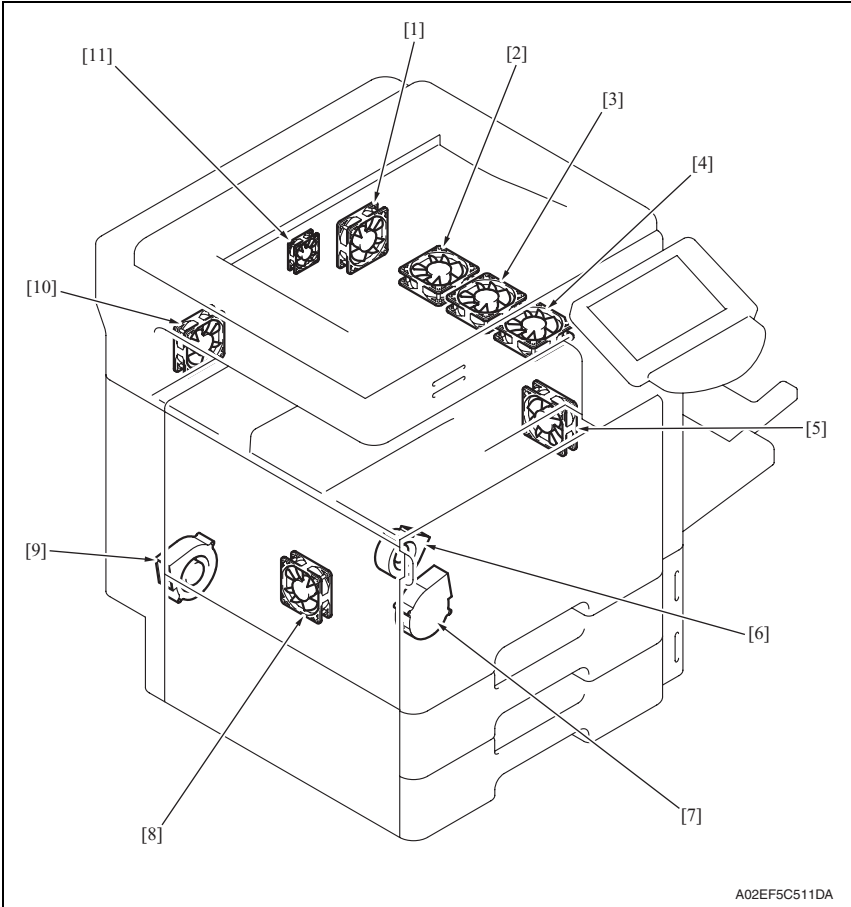

A02EF5CS11DA

- |   |  |
|---|--|
| ⚠ [1] Paper cooling fan motor (FM7)     | [7] Cooling fan motor/1 (FM1)            |
| [2] Fusing cooling fan motor/2 (FM10)   | [8] Power supply cooling fan motor (FM5) |
| [3] Fusing cooling fan motor/3 (FM11) * | [9] Exhaust fan motor (FM4)              |
| [4] Fusing cooling fan motor/1 (FM9)    | [10] Cooling fan motor/2 (FM2)           |
| [5] Suction fan motor (FM8)             | [11] MFP board cooling fan motor (FM6)   |
| ⚠ [6] Toner suction fan motor (FM3)     |  |

\*: bizhub C353 only

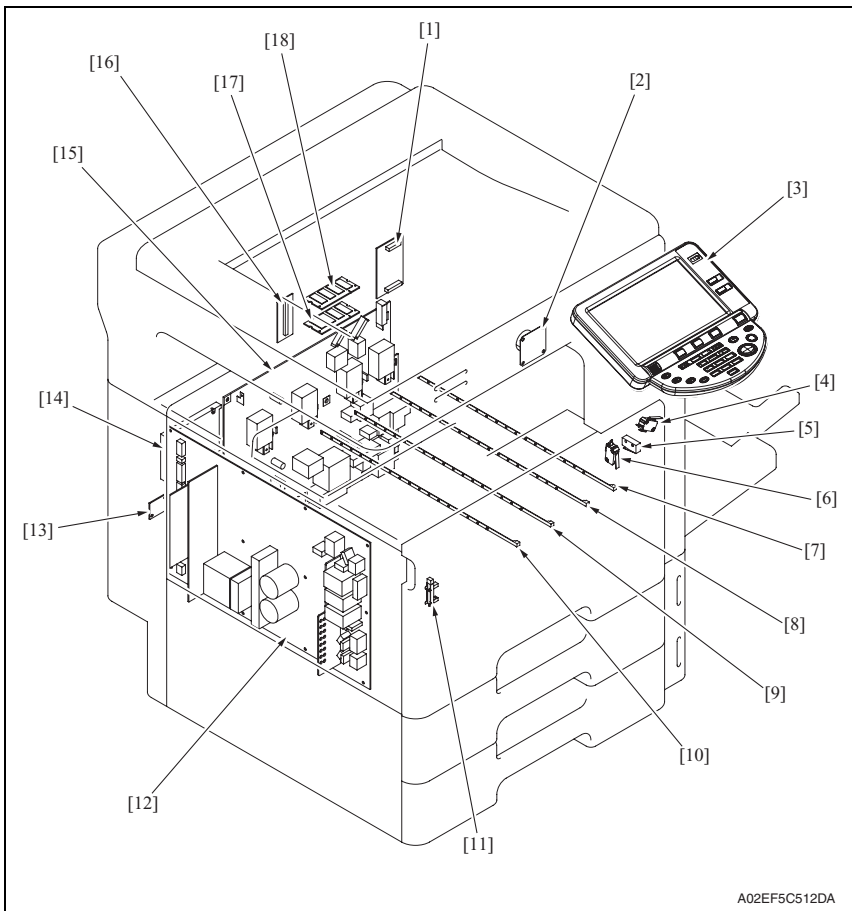

A02EF5C512DA

- |                              |                                     |
|------------------------------|-------------------------------------|
| [1] NVRAM board (NRB)        | [10] Erase lamp/Y (EL/Y)            |
| [2] Speaker (SP)             | [11] Waste toner full sensor (PS32) |
| [3] Control panel (UN201)    | [12] DC power supply (DCPU)         |
| [4] Right door switch (S5)   | [13] Service EEPROM board (SV ERB)  |
| [5] Front door switch/1 (S3) | [14] Hard disk drive (HDD)          |
| [6] Front door switch/2 (S4) | [15] High voltage unit (HV)         |
| [7] Erase lamp/K (EL/K)      | [16] JMP board (JMPB)               |
| [8] Erase lamp/C (EL/C)      | [17] SODIMM/1 (SODIMM/1)            |
| [9] Erase lamp/M (EL/M)      | [18] SODIMM/2 (SODIMM/2)            |



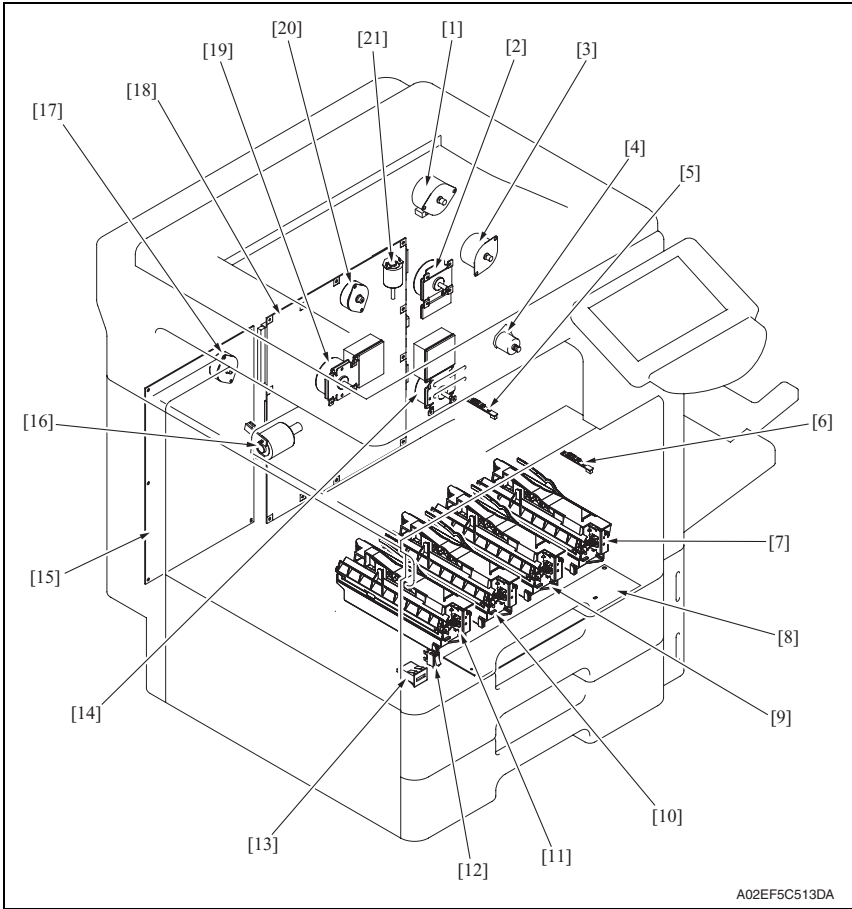

A02EF5C513DA

- |   |  |
|---|--|
| [1] Switchback motor (M6)                     | [12] Main power switch (S1)              |
| [2] Fusing motor (M5)                         | [13] Total counter (TCT)                 |
| [3] Duplex transport motor (M7)               | [14] Transport motor (M1)                |
| [4] 2nd image transfer retraction motor (M11) | [15] Printer control board (PRCB)        |
| [5] IDC registration sensor/YC (IDCS/YC)      | [16] Color dev. unit engaged motor (M10) |
| [6] IDC registration sensor/MK (IDCS/MK)      | [17] Toner supply motor/YM (M4)          |
| [7] PH unit/K                                 | [18] MFP board (MFPB)                    |
| [8] PH relay board (REYB/PH)                  | [19] Color PC motor (M2)                 |
| [9] PH unit/C                                 | [20] Toner supply motor/CK (M3)          |
| [10] PH unit/M                                | [21] Fusing retraction motor (M12)       |
| [11] PH unit/Y                                |  |

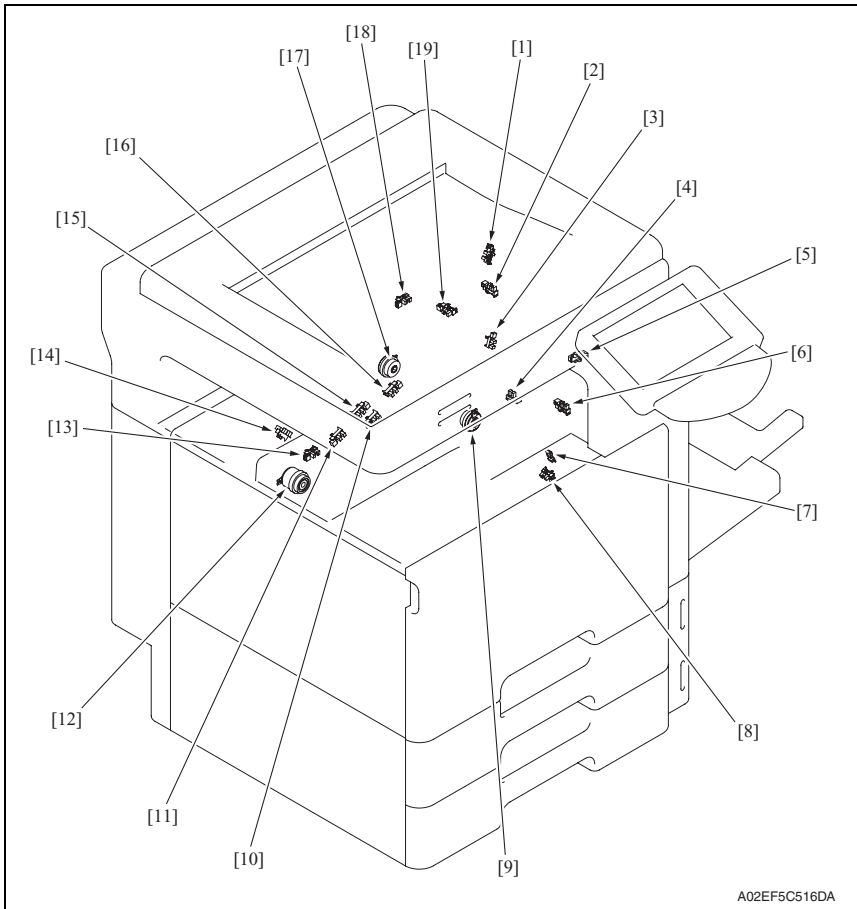

A02EF5C516DA

- |   |   |
|---|---|
| [1] Duplex paper passage sensor/1 (PS33)                | [11] Color PC drive main sensor (PS27)              |
| [2] Duplex door sensor (PS35)                           | [12] Transfer belt retraction clutch (CL7)          |
| [3] Duplex paper passage sensor/2 (PS34)                | [13] Transfer belt retraction sensor (PS31)         |
| [4] 2nd image transfer welding alienation sensor (PS36) | [14] Color dev. unit engaged position sensor (PS26) |
| [5] Fusing retraction sensor (PS37)                     | [15] Color PC drive sub sensor (PS28)               |
| [6] Fusing loop detect sensor (PS24)                    | [16] Black PC drive sub sensor (PS30)               |
| [7] Temperature/humidity sensor (TEM/HUM)               | [17] Tim. roller clutch (CL6)                       |
| [8] Sensor in front of tim. roller (PS23)               | [18] Fusing roller retraction sensor (PS38)         |
| [9] Developing clutch/K (CL5)                           | [19] Paper exit sensor (PS25)                       |
| [10] Black PC drive main sensor (PS29)                  |   |

## 19.1.3 Tray 1, manual bypass tray

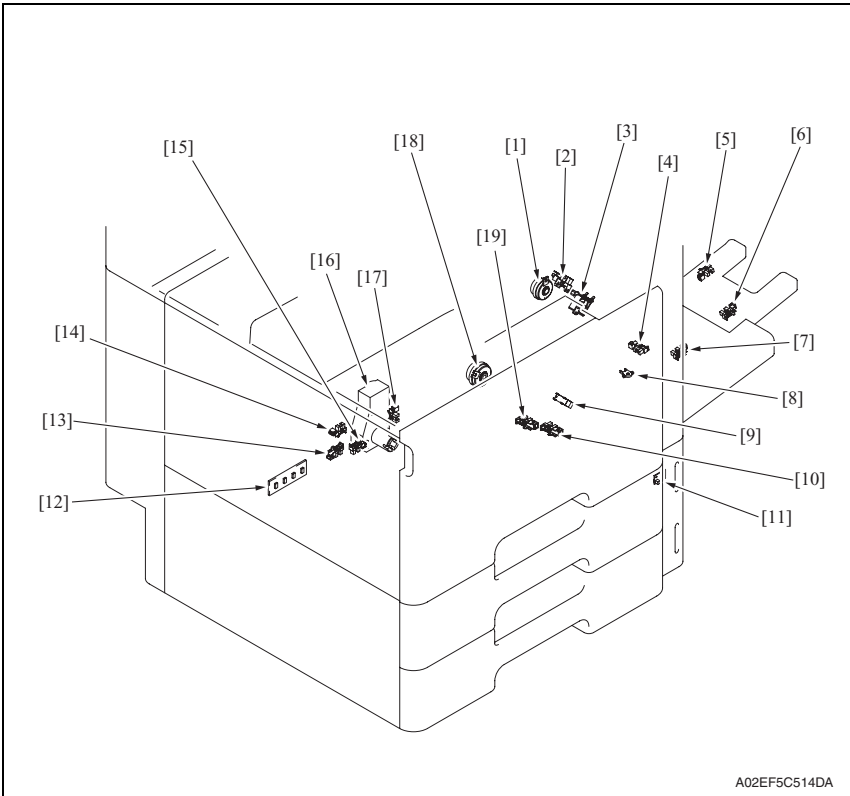

- |   |   |
|---|---|
| [1] Manual paper feed clutch (CL4)              | [11] Paper feed tray 1 paper empty indicator board (PEIB/1) |
| [2] Manual lift-up position sensor (PS17)       | [12] Paper feed tray 1 paper FD size detect board (PSDTB/1) |
| [3] Manual pick-up solenoid (SL1)               | [13] Paper feed tray 1 paper CD size detect sensor/2 (PS6)  |
| [4] Manual paper empty sensor (PS21)            | [14] Paper feed tray 1 device detection sensor (PS2)        |
| [5] Manual multi FD size sensor/3 (PS20)        | [15] Paper feed tray 1 paper CD size detect sensor/1 (PS5)  |
| [6] Manual multi FD size sensor/2 (PS19)        | [16] Paper feed tray 1 lift-up motor (M8)                   |
| [7] Manual multi FD size sensor/1 (PS18)        | [17] Paper feed tray 1 near empty sensor (PS4)              |
| [8] Manual CD size sensor (PS22)                | [18] Paper feed tray 1 paper feed clutch (CL1)              |
| [9] Paper feed tray 1 chain feed sensor (PS1)   | [19] Paper feed tray 1 upper limit sensor (PS8)             |
| [10] Paper feed tray 1 paper empty sensor (PS7) |   |

19.1.4 Tray 2

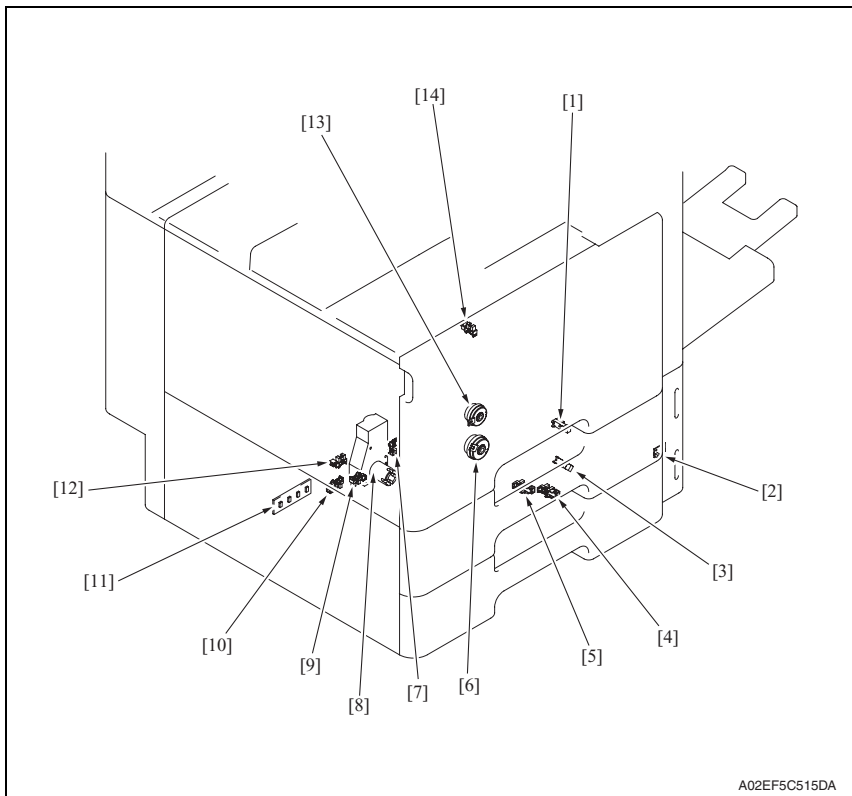

- |  |   |
|--|---|
| [1] Paper feed tray 2 vertical transport sensor (PS16)     | [8] Paper feed tray 2 lift-up motor (M9)                    |
| [2] Paper feed tray 2 paper empty indicator board (PEIB/2) | [9] Paper feed tray 2 paper CD size detect sensor/1 (PS11)  |
| [3] Paper feed tray 2 paper feed sensor (PS14)             | [10] Paper feed tray 2 paper CD size detect sensor/2 (PS12) |
| [4] Paper feed tray 2 paper empty sensor (PS13)            | [11] Paper feed tray 2 paper FD size detect board (PSDTB/2) |
| [5] Paper feed tray 2 upper limit sensor (PS15)            | [12] Paper feed tray 2 device detection sensor (PS10)       |
| [6] Paper feed tray 2 paper feed clutch (CL2)              | [13] Paper feed tray 2 vertical transport clutch (CL3)      |
| [7] Paper feed tray 2 near empty sensor (PS9)              | [14] Paper feed tray 2 door sensor (PS3)                    |

## 19.2 DF-611 (option)

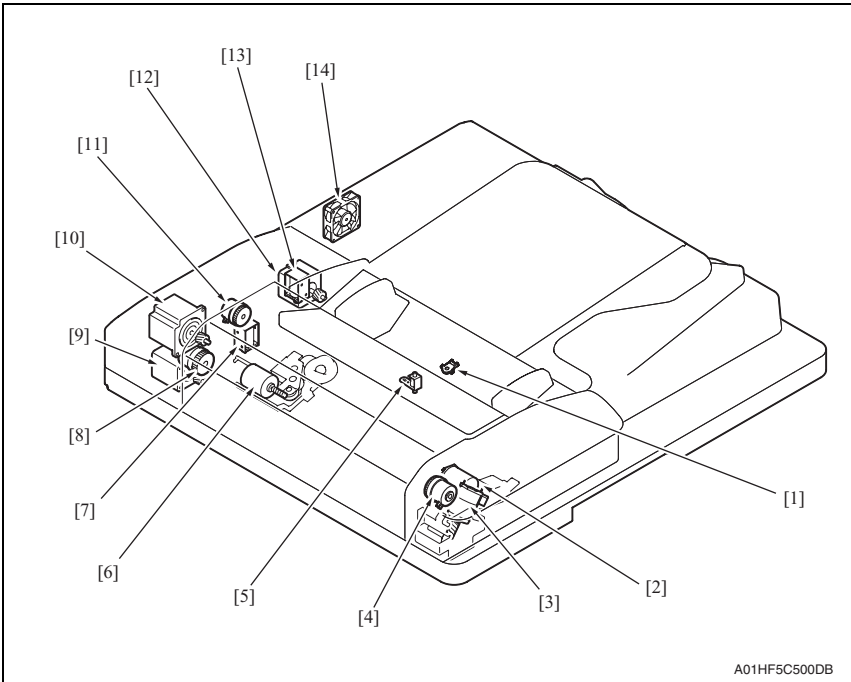

- |  |                                 |
|--|---------------------------------|
| [1] Document width detection variable resistor (VR1) | [8] Registration clutch (CL1)   |
| [2] Switchback roller pressure/retraction motor (M5) | [9] Reading motor (M1)          |
| [3] Reading roller pressure/retraction motor (M4)    | [10] Take-up motor (M2)         |
| [4] Brake clutch (CL3)                               | [11] Take-up clutch (CL2)       |
| [5] Stamp solenoid (SD3) *                           | [12] Exit motor (M3)            |
| [6] Lift-up motor (M6)                               | [13] Switch back solenoid (SD1) |
| [7] Exit switch back solenoid (SD2)                  | [14] Cooling fan (FM1)          |

\* : option

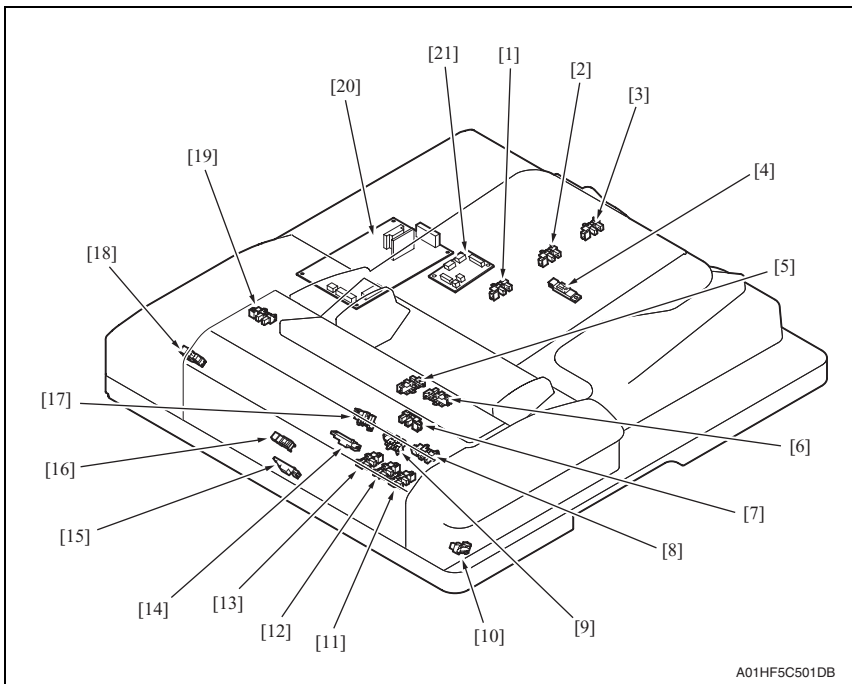

- [1] Length sensor/1 (PS10)
- [2] Length sensor/3 (PS12)
- [3] Length sensor/4 (PS13)
- [4] Length sensor/2 (PS11)
- [5] Lift up upper sensor (PS16)
- [6] Empty sensor (PS14)
- [7] After separate sensor (PS4)
- [8] Reverse roller sensor (PS7)
- [9] Lift up lower sensor (PS15)
- [10] Read roller sensor (PS6)
- [11] Consolidation/3 (PS17)
- [12] Consolidation/2 (PS18)
- [13] Consolidation/1 (PS19)
- [14] Reverse registration sensor (PS8)
- [15] Before read sensor (PS9)
- [16] Registration sensor (PS3)
- [17] Exit sensor (PS5)
- [18] Read open/close sensor (PS2)
- [19] Feed open/close sensor (PS1)
- [20] DF control board (DFCB)
- [21] Relay board (REYB)

### 19.3 PC-104/204 (option)

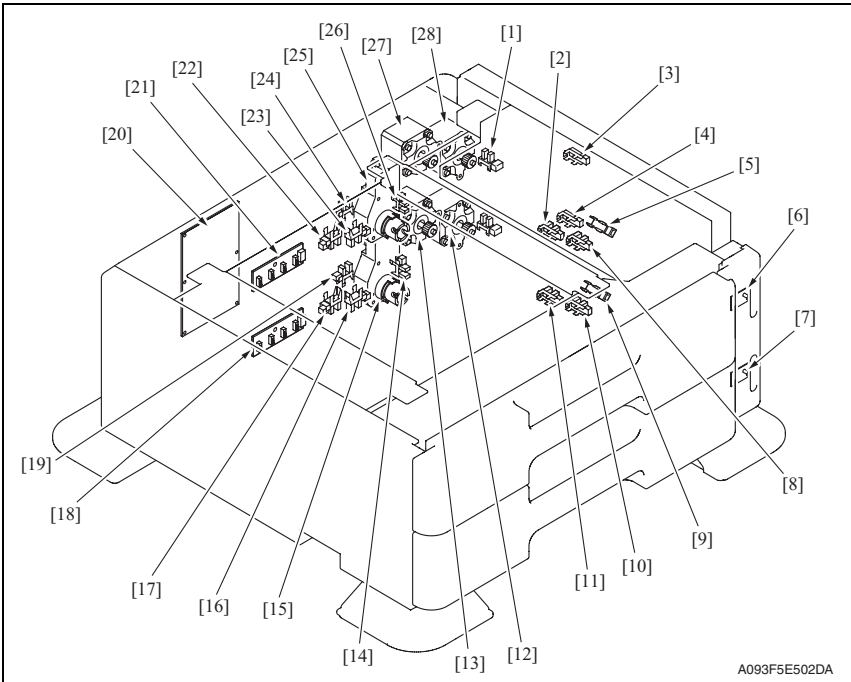

A093F5E502DA

- |   |  |
|---|--|
| [1] Tray3 door set sensor (PS111)                         | [15] Tray4 lift-up motor (M125)                |
| [2] Tray3 upper limit sensor (PS114)                      | [16] Tray4 CD paper size sensor/2 (PS128)      |
| [3] Tray3 vertical transport sensor (PS117)               | [17] Tray4 CD paper size sensor/1 (PS127)      |
| [4] Tray4 vertical transport sensor (PS126)               | [18] Tray4 paper size detect board/2 (PSDTB/2) |
| [5] Tray3 paper feed sensor (PS116)                       | [19] Tray4 device detection sensor (PS121)     |
| [6] Paper feed tray3 paper empty indicator board (PEIB/1) | [20] PC Control board (PCCB)                   |
| [7] Paper feed tray4 paper empty indicator board (PEIB/2) | [21] Tray3 paper size detect board/1 (PSDTB/1) |
| [8] Tray3 empty sensor (PS115)                            | [22] Tray3 CD paper size sensor/1 (PS118)      |
| [9] Tray4 paper feed sensor (PS125)                       | [23] Tray3 CD paper size sensor/2 (PS119)      |
| [10] Tray4 empty sensor (PS124)                           | [24] Tray3 device detection sensor (PS112)     |
| [11] Tray4 upper limit sensor (PS123)                     | [25] Tray3 lift-up motor (M124)                |
| [12] Tray4 vertical transport motor (M121)                | [26] Tray3 near empty sensor (PS113)           |
| [13] Tray4 paper feed motor (M123)                        | [27] Tray3 paper feed motor (M122)             |
| [14] Tray4 near empty sensor (PS122)                      | [28] Tray3 vertical transport motor (M120)     |

### 19.4 PC-405 (option)

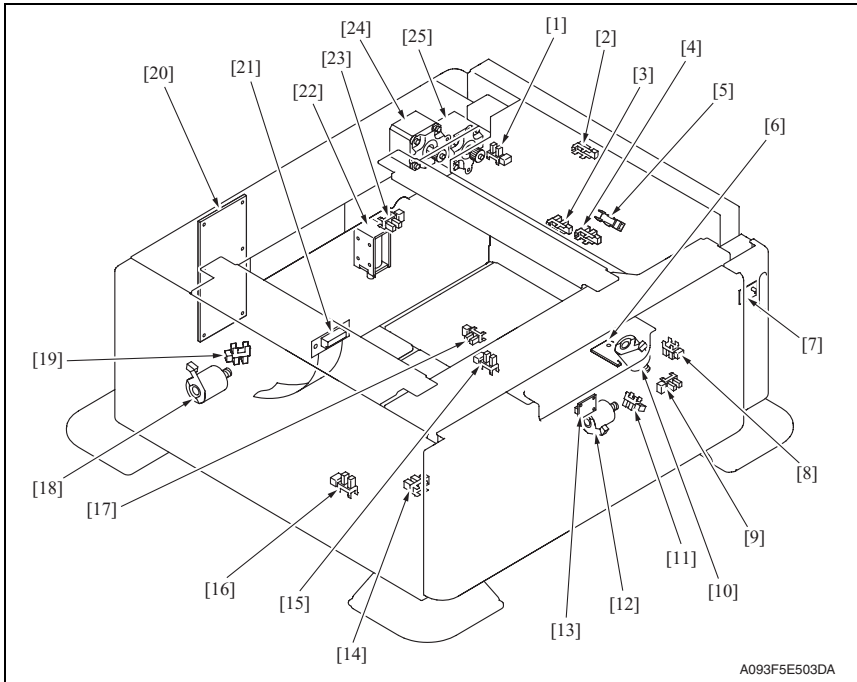

- |   |  |
|---|--|
| [1] Door sensor (PS5)                                     | [14] Shift tray empty sensor (PS9)         |
| [2] Vertical transport sensor (PS2)                       | [15] Shift tray stop sensor (PS11)         |
| [3] Lift-up upper sensor (PS4)                            | [16] Shift tray home sensor (PS12)         |
| [4] Paper empty sensor (PS3)                              | [17] Lift-up lower sensor (PS13)           |
| [5] Paper feed sensor (PS1)                               | [18] Division board position motor (M3)    |
| [6] Main tray paper empty board (MTPEB)                   | [19] Division board position sensor (PS14) |
| [7] Paper feed tray3 paper empty indicator board (PEIB/1) | [20] PC control board (PCCB)               |
| [8] Elevator motor pulse sensor (PS10)                    | [21] Relay board (REYB)                    |
| [9] Lower over run sensor (PS7)                           | [22] Tray lock solenoid (SD1)              |
| [10] Elevator motor (M5)                                  | [23] Cassette open sensor (PS6)            |
| [11] Shift motor pulse sensor (PS8)                       | [24] Paper feed motor (M1)                 |
| [12] Shift motor (M4)                                     | [25] Vertical transport motor (M2)         |
| [13] Manual down control board (MDCB)                     |  |



## 19.5 FS-519 (option)

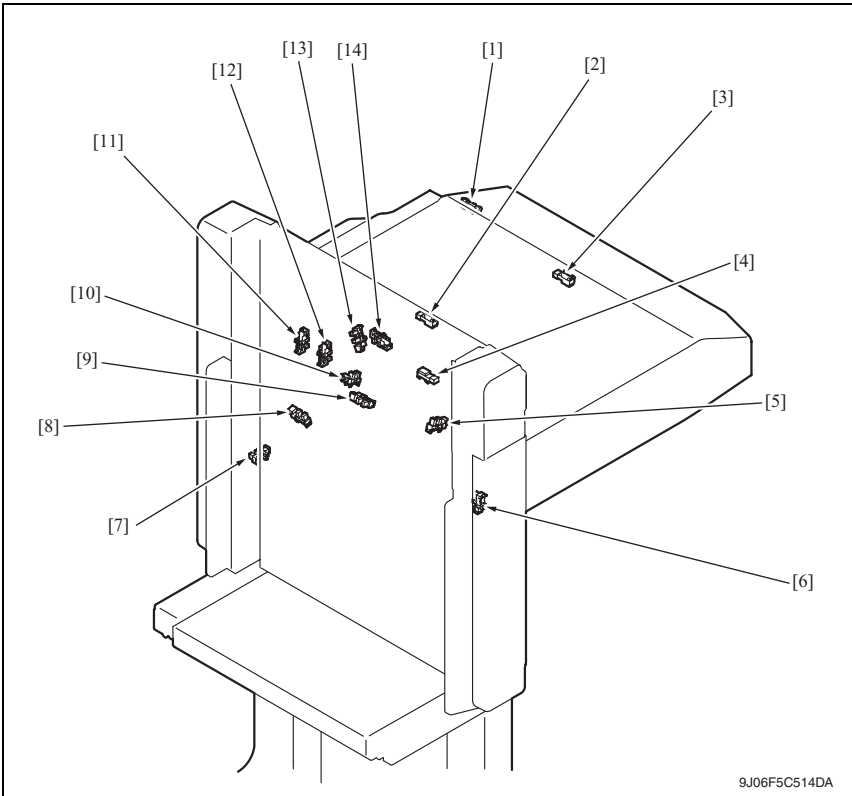

9J06F5C514DA

- |   |   |
|---|---|
| [1] Entrance switch back sensor (PS4)         | [8] Elevator top face detection sensor (PS12) |
| [2] Transport sensor (PS2)                    | [9] Exit paddle home position sensor (PS6)    |
| [3] Entrance sensor (PS1)                     | [10] Alignment home position sensor /1 (PS7)  |
| [4] Storage tray detect sensor (PS3)          | [11] Stapler save position sensor (PS10)      |
| [5] Alignment home position sensor /2 (PS8)   | [12] Staple home position sensor (PS9)        |
| [6] Elevator tray home position sensor (PS11) | [13] Shutter home position sensor (PS14)      |
| [7] Elevator tray lower limit sensor (PS13)   | [14] Exit roller home position sensor (PS5)   |

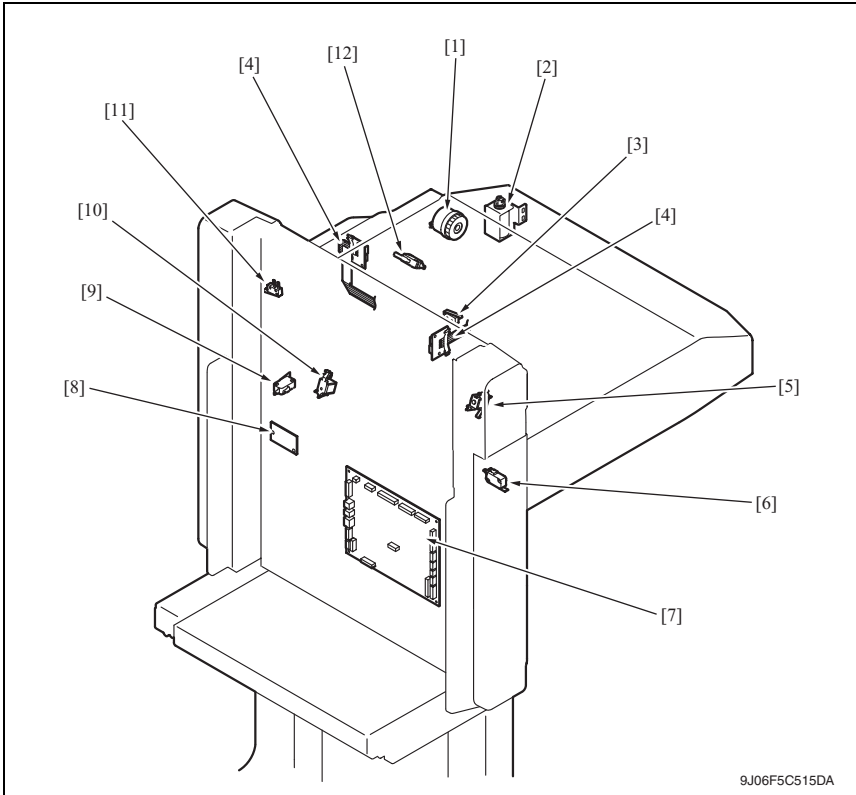

9J06F5C515DA

- |                                    |                                 |
|------------------------------------|---------------------------------|
| [1] Skew registration clutch (CL1) | [7] FS control board (FSCB)     |
| [2] Duplex guide solenoid (SD3)    | [8] Relay board/1 (REYB/1)      |
| [3] Shutter detect switch (SW2)    | [9] Slide switch (SW4)          |
| [4] Relay board/2 (REYB/2)         | [10] Exit paddle solenoid (SD2) |
| [5] Storage paddle solenoid (SD1)  | [11] Elevator tray switch (SW3) |
| [6] Front door switch (SW1)        | [12] Middle guide switch (SW5)  |

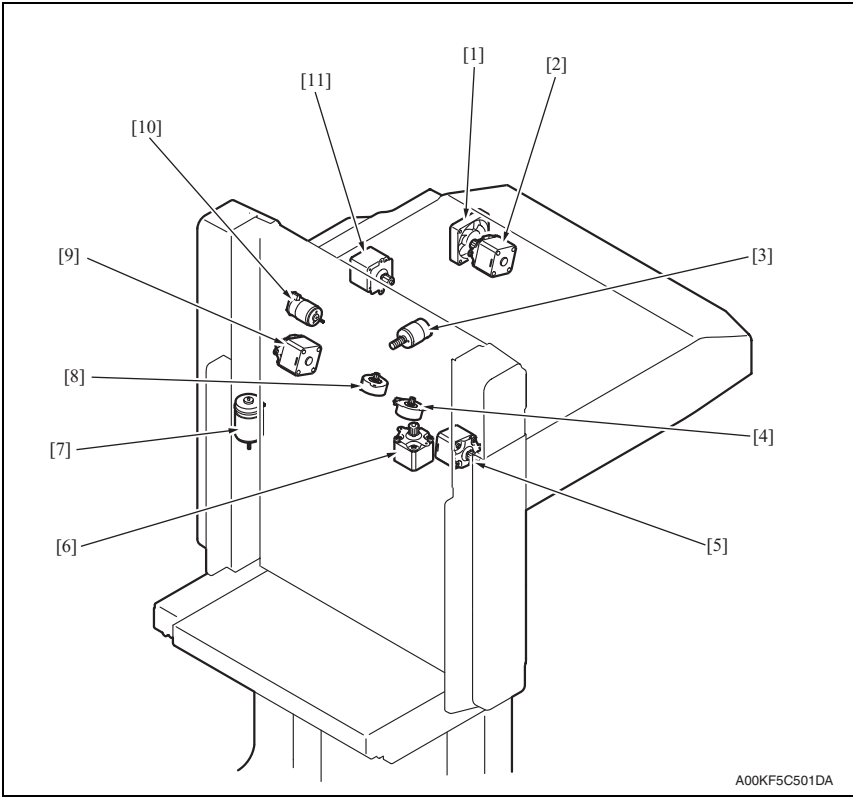

- |                                     |                             |
|-------------------------------------|-----------------------------|
| [1] Cooling fan motor (FM9)         | [7] Elevator motor (M11)    |
| [2] Entrance motor (M1)             | [8] Align motor/1 (M5)      |
| [3] Exit roller motor (M10)         | [9] Transport motor/2 (M3)  |
| [4] Align motor/2 (M6)              | [10] Shutter motor (M8)     |
| [5] Exit motor (M4)                 | [11] Transport motor/1 (M2) |
| [6] Stapling unit moving motor (M7) |                             |

### 19.6 PK-515 (option)

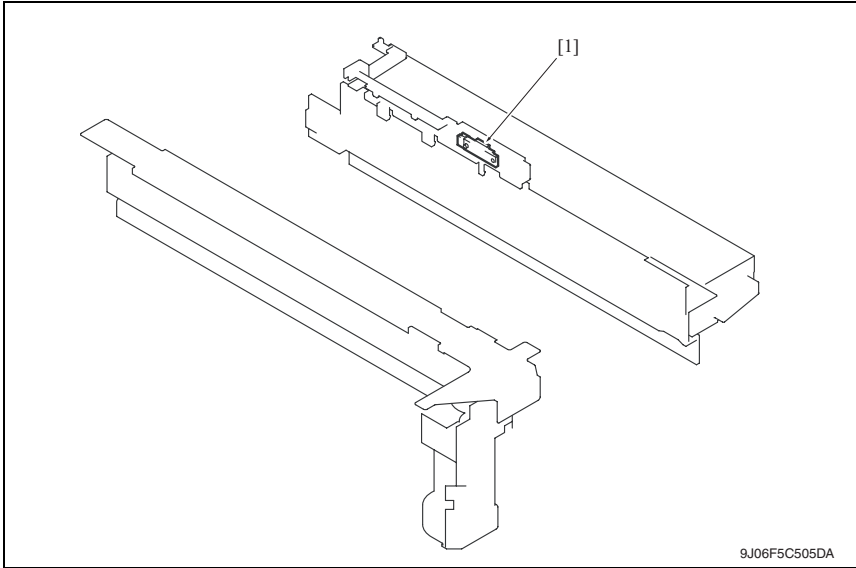

9J06F5C505DA

[1] Punch trash full sensor (PS30)

## 19.7 MT-502 (option)

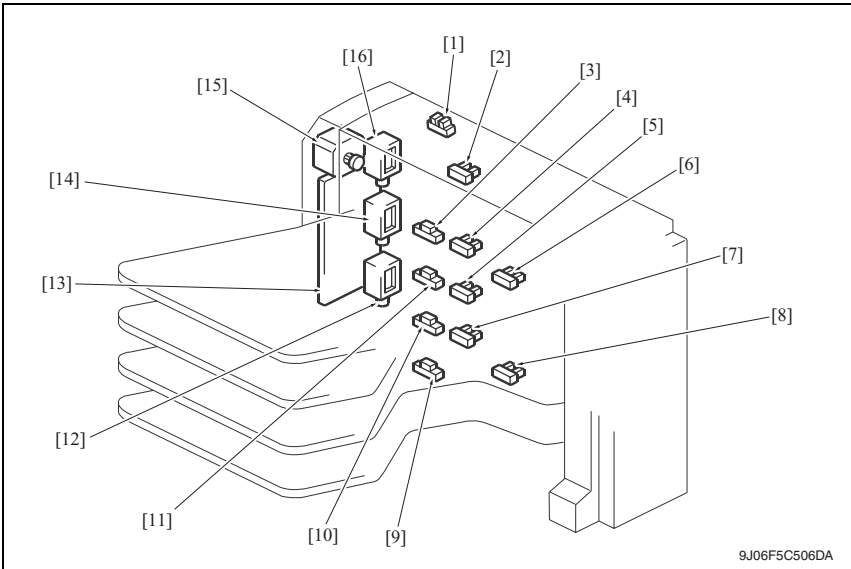

- |   |  |
|---|--|
| [1] Cover open/close sensor (PS11)      | [9] Paper detection sensor 1 (PS1)           |
| [2] Paper full detection sensor 4 (PS8) | [10] Paper detection sensor 2 (PS2)          |
| [3] Paper detection sensor 4 (PS4)      | [11] Paper detection sensor 3 (PS3)          |
| [4] Paper full detection sensor 3 (PS7) | [12] Bin entrance switching solenoid 1 (SD1) |
| [5] Paper full detection sensor 2 (PS6) | [13] MT control board (MTCB)                 |
| [6] Upper transport sensor (PS9)        | [14] Bin entrance switching solenoid 2 (SD2) |
| [7] Paper full detection sensor 1 (PS5) | [15] Transport motor (M1)                    |
| [8] Lower transport sensor (PS10)       | [16] Bin entrance switching solenoid 3 (SD3) |

### 19.8 SD-505 (option)

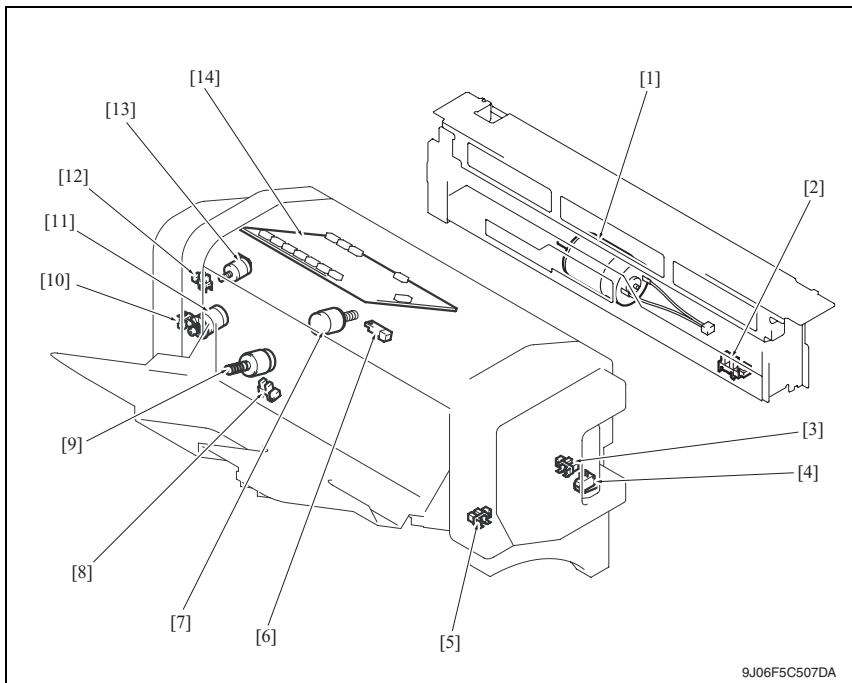

9J06F5C507DA

- |   |   |
|---|---|
| [1] Crease motor (M10)                        | [8] Saddle tray empty sensor (PS21)                 |
| [2] Crease roller home position sensor (PS22) | [9] In & out guide motor (M13)                      |
| [3] Layable guide home sensor (PS24)          | [10] Transport pulse sensor (PS25)                  |
| [4] Saddle opening switch (SW4)               | [11] Saddle exit motor (M8)                         |
| [5] In & out guide home sensor (PS23)         | [12] Saddle exit roller home position sensor (PS18) |
| [6] Saddle exit sensor (PS20)                 | [13] Saddle exit open/close motor (M9)              |
| [7] Layable guide motor (M14)                 | [14] SD control board (SDCB)                        |

## 19.9 JS-505 (option)

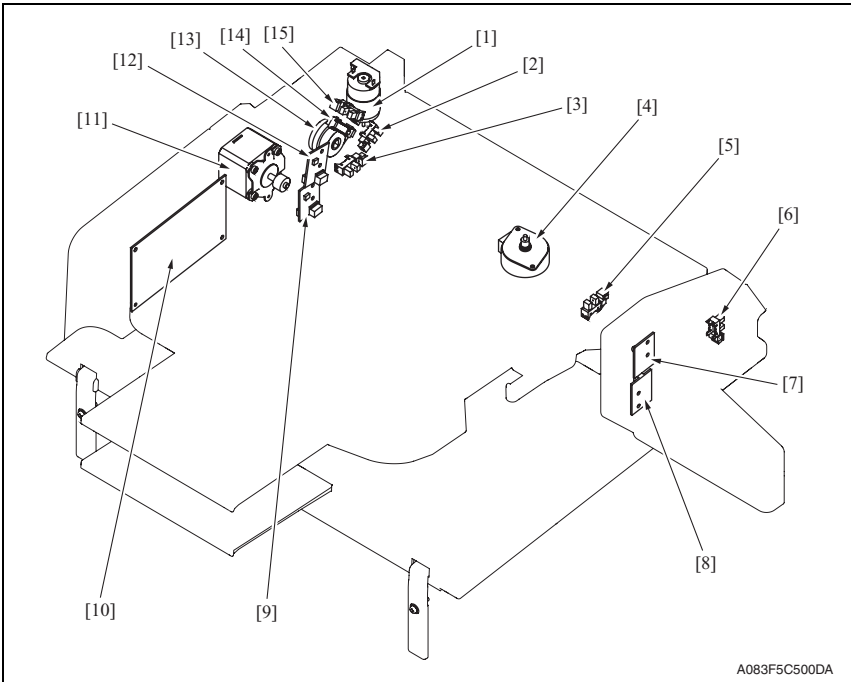

A083F5C500DA

- |   |  |
|---|--|
| [1] Route change motor (M3)                             | [9] Lower tray paper full detect board/PR (T1FDTB/PR)  |
| [2] Route change home sensor (PS4)                      | [10] JS control board (JSCB)                           |
| [3] Pressure/retraction home sensor (PS5)               | [11] Transport Motor (M1)                              |
| [4] Shift motor (M2)                                    | [12] Upper tray paper full detect board/PR (T2FDTB/PR) |
| [5] Shift home sensor (PS6)                             | [13] Roller pressure/retraction clutch (CL1)           |
| [6] Front door sensor (PS3)                             | [14] Lower tray exit sensor (PS1)                      |
| [7] Upper tray paper full detect board/LED (T2FDTB/LED) | [15] Upper tray exit sensor (PS2)                      |
| [8] Lower tray paper full detect board/LED (T1FDTB/LED) |  |

**19.10 FS-609 (option)**

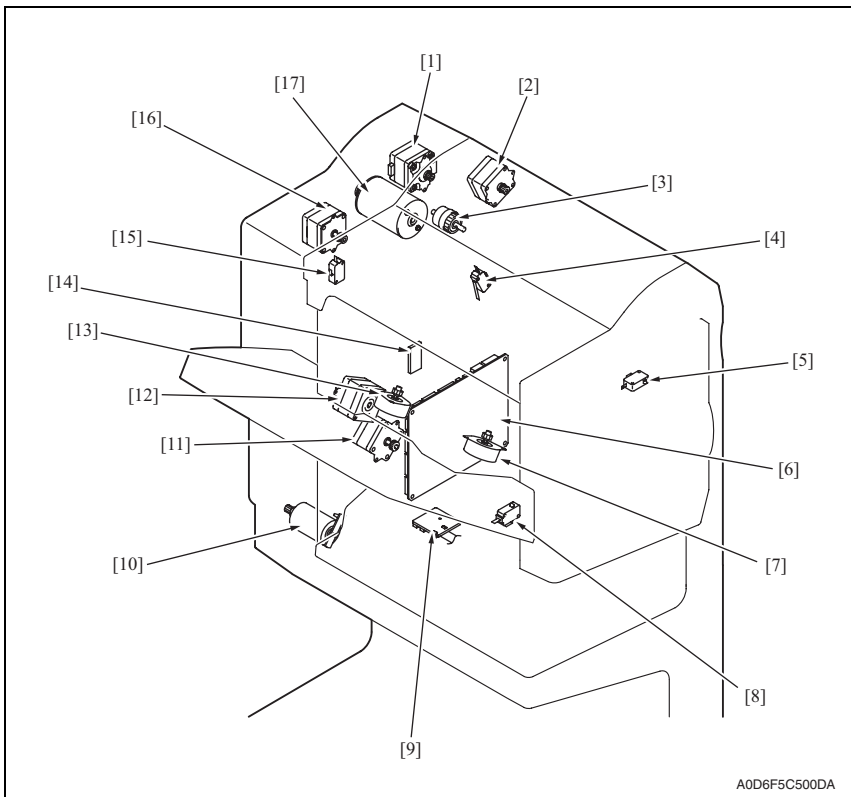

A0D6F5C500DA

- |                                       |                                    |
|---------------------------------------|------------------------------------|
| [1] Transport motor (M1)              | [10] Lift motor (M6)               |
| [2] Entrance motor (M9)               | [11] Slide motor (M8)              |
| [3] Saddle clutch (CL1)               | [12] Exit motor (M3)               |
| [4] Joint open switch (SW2)           | [13] Rear aligning motor (M5)      |
| [5] Front door open switch (SW1)      | [14] EEPROM (ER)                   |
| [6] Finisher control board (FSCB)     | [15] Stapler safely switch/R (SW3) |
| [7] Front aligning motor (M4)         | [16] Paddle motor (M2)             |
| [8] Stapler safely switch/F (SW4)     | [17] Staple/folding motor (M7)     |
| [9] Slide home position sensor (PS18) |                                    |



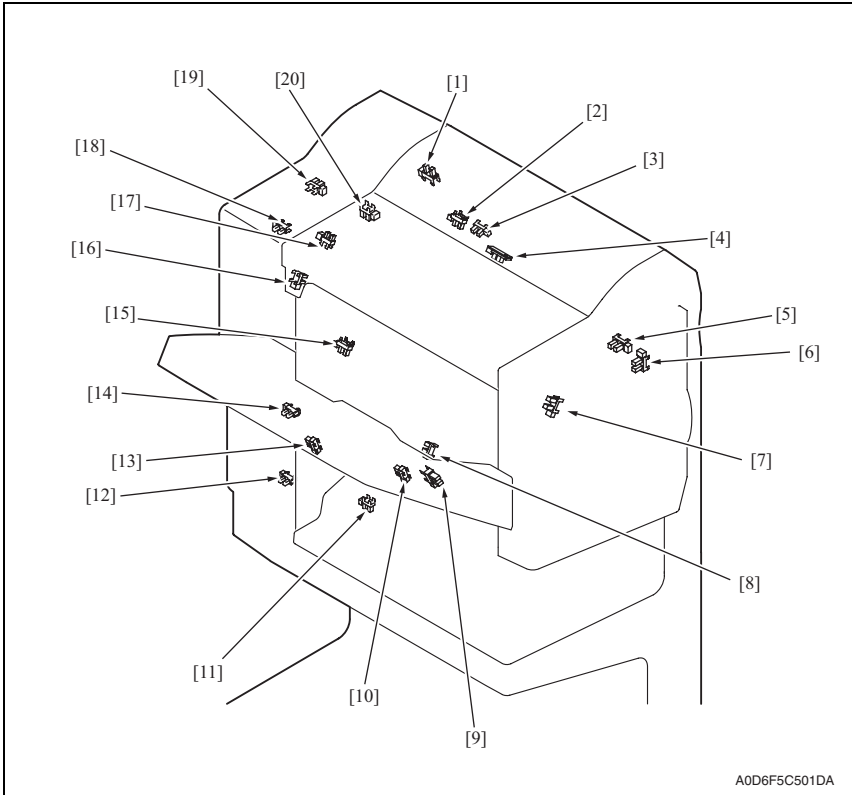

- |   |   |
|---|---|
| [1] Entrance sensor (PS1)                           | [11] Saddle tray sensor (PS13)                      |
| [2] Folding roller home position sensor (PS12)      | [12] Lift motor clock sensor (PS17)                 |
| [3] Folding home position sensor (PS11)             | [13] Stack full sensor (PS24)                       |
| [4] Folding position sensor (PS10)                  | [14] Lift lower limit sensor (PS16)                 |
| [5] Upper cover open sensor (PS23)                  | [15] Exit belt home position sensor (PS7)           |
| [6] Front door open sensor (PS22)                   | [16] Rear aligning plate home position sensor (PS5) |
| [7] Front aligning plate home position sensor (PS4) | [17] Paddle home position sensor (PS2)              |
| [8] Finisher tray sensor (PS6)                      | [18] Lift upper limit sensor (PS15)                 |
| [9] Exit tray sensor (PS8)                          | [19] Staple/folding motor clock sensor (PS14)       |
| [10] Exit tray home position sensor (PS9)           | [20] Bundle exit roller home position sensor (PS3)  |

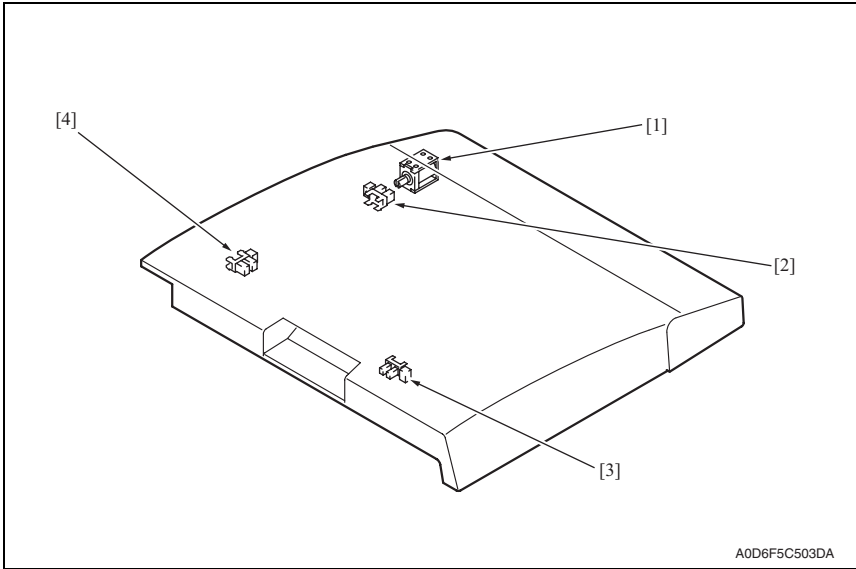

[1] Entrance switching solenoid (SD1)

[3] Paper sensor (PS25)

[2] Turnover empty sensor (PS27)

[4] Horizontal unit door sensor (PS26)



## 19.11 PK-501 (option)

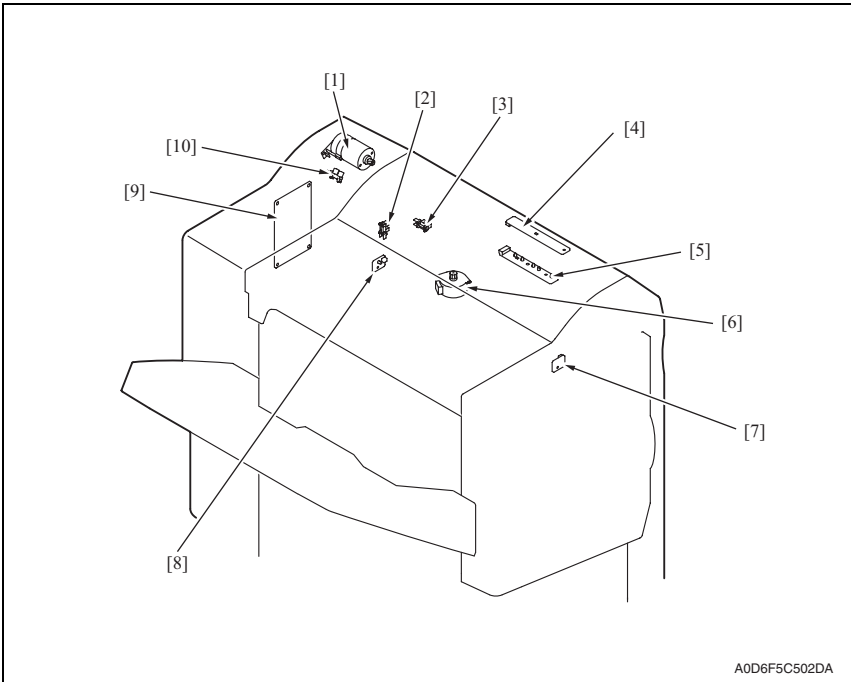

- |   |   |
|---|---|
| [1] Punch motor (M1)                    | [6] Side registration motor (M2)                  |
| [2] Side registration home sensor (PS2) | [7] Punch trash full LED board (PTFB/LED)         |
| [3] Punch motor cock sensor (PS3)       | [8] Punch trash full photo sensor board (PTFB/PR) |
| [4] Photo sensor board (PSB)            | [9] Punch control board (PKCB)                    |
| [5] LED board (LEDB)                    | [10] Punch home position sensor (PS1)             |

# 20. Connector layout drawing

## Description

- Number of pin ① Possible to confirm by removing external cover.
- [1] Not possible to confirm by removing external cover.

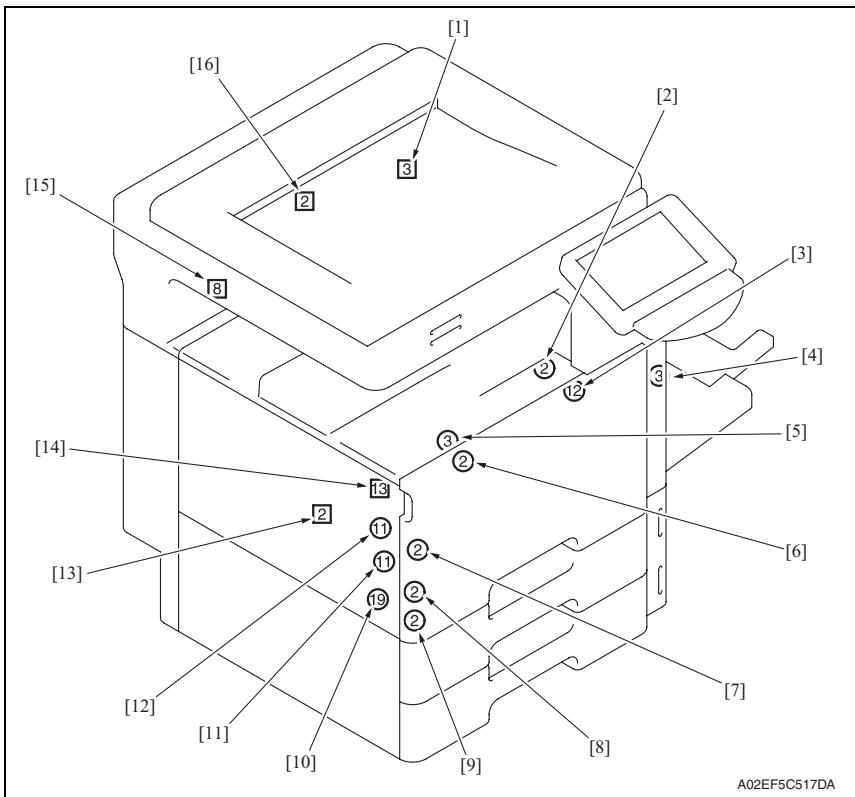

A02EF5C517DA



No.	CN No.	Location	No.	CN No.	Location
[1]	CN68	E-6	[9]	CN36	D-11
[2]	CN1	E-1	[10]	CN29	E-9 to 10
[3]	CN4	E-2	[11]	CN18	E-8
[4]	CN63	D-5	[12]	CN62	E-5
[5]	CN10	E-3	[13]	CN67	E-6
[6]	CN2	E-1	[14]	CN57	E-3 to 4
[7]	CN22	D-9	[15]	CN131	J-8
[8]	CN35	D-11	[16]	CN6	O-3



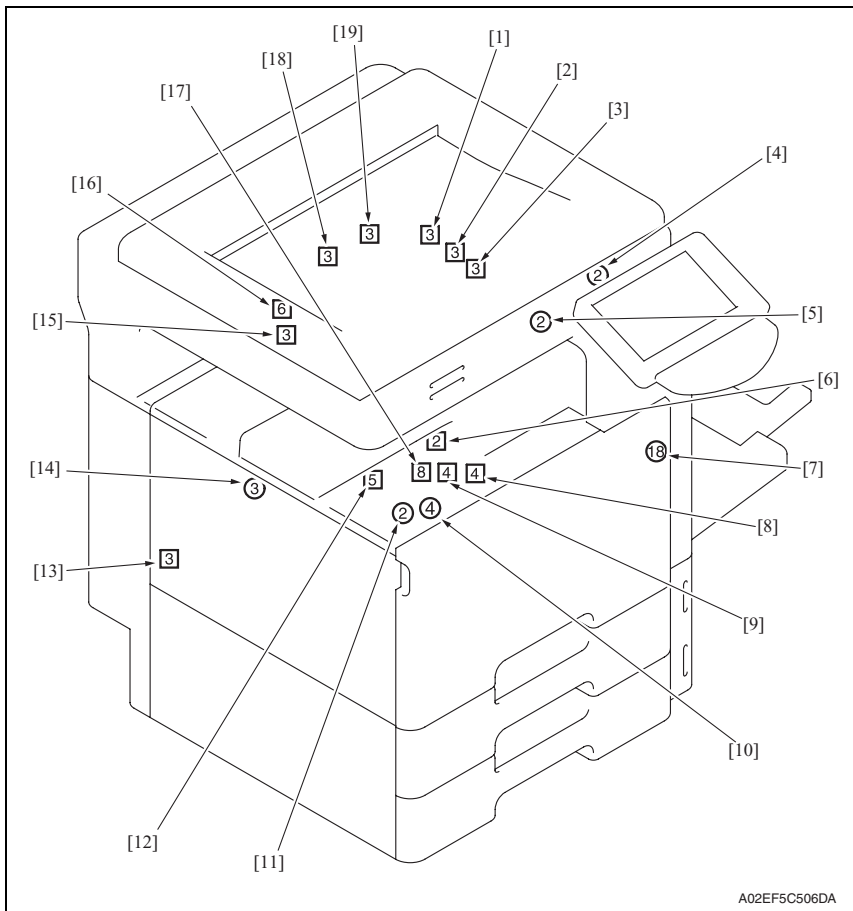

No.	CN No.	Location	No.	CN No.	Location
[1]	CN140	D-20	[11]	CN8	J-17
[2]	CN55	D-20	[12]	CN69	E-17 to 18
[3]	CN54	D-20	[13]	CN126	J-7 to 8
[4]	CN23	U-8	[14]	CN127	J-8
[5]	CNMT	D-18	[15]	CN148	E-20
[6]	CN74	D-17	[16]	CN53	E-20
[7]	CN47	D-21	[17]	CN141	E-14
[8]	CN146	E-17	[18]	CN137	D-26
[9]	CN75	E-16	[19]	CN85	D-25
[10]	CN39	J-17 to 18			

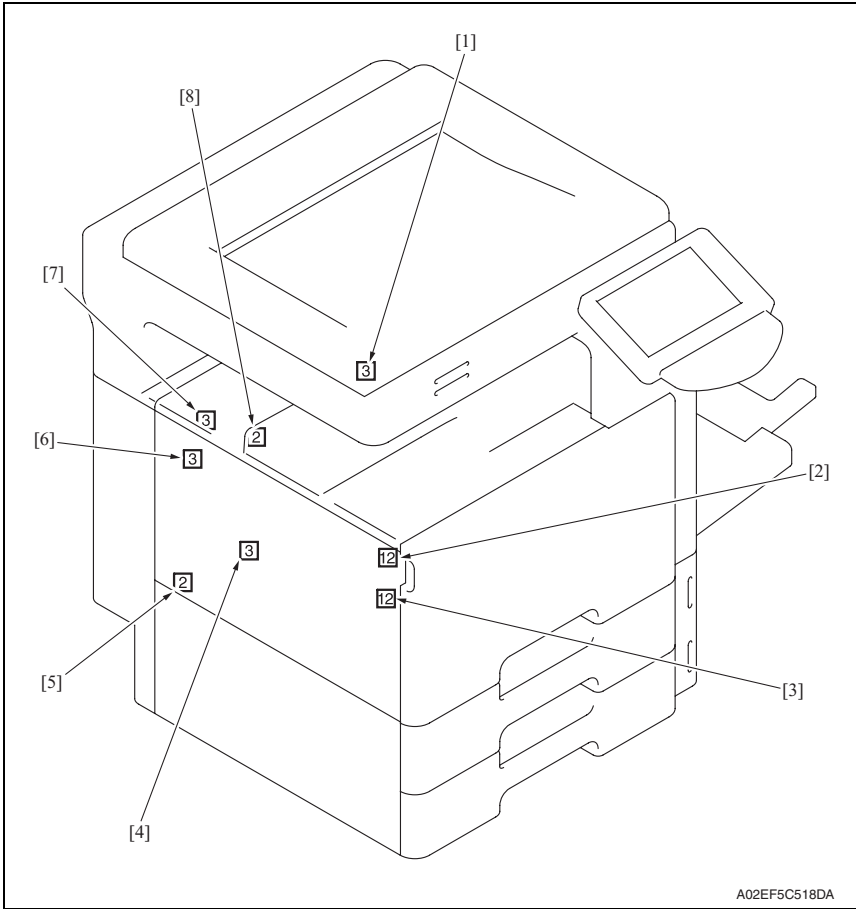

A02EF5C518DA



No.	CN No.	Location	No.	CN No.	Location
[1]	CN49	I-9	[5]	CN2AC	J-16
[2]	CN103	I-11	[6]	CN120	J-7
[3]	CN98	I-10	[7]	CN125	J-7
[4]	CN136	D-28	[8]	CN84	D-25

# 21. Timing chart

## 21.1 Main body

Color mode/A4 or 8 1/2 x 11/tray1

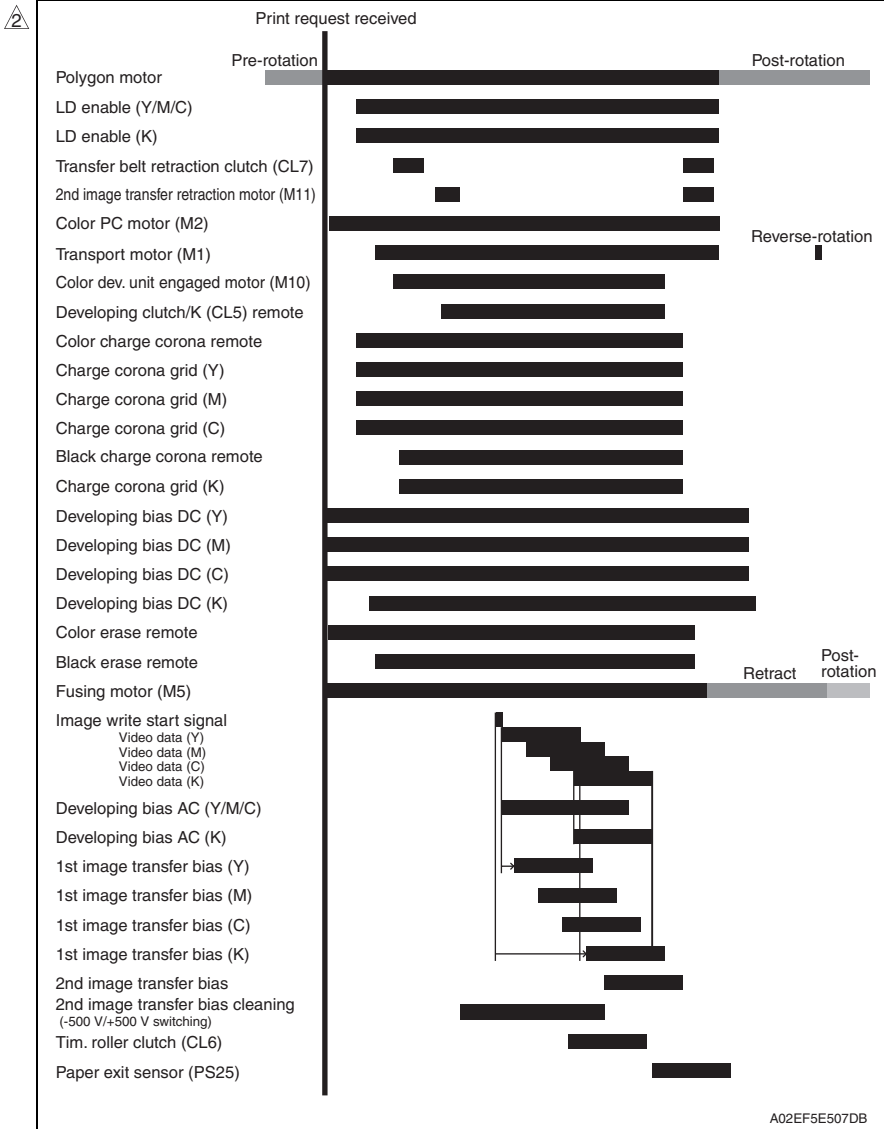

## 21.2 DF-611

### 21.2.1 1-sided mode

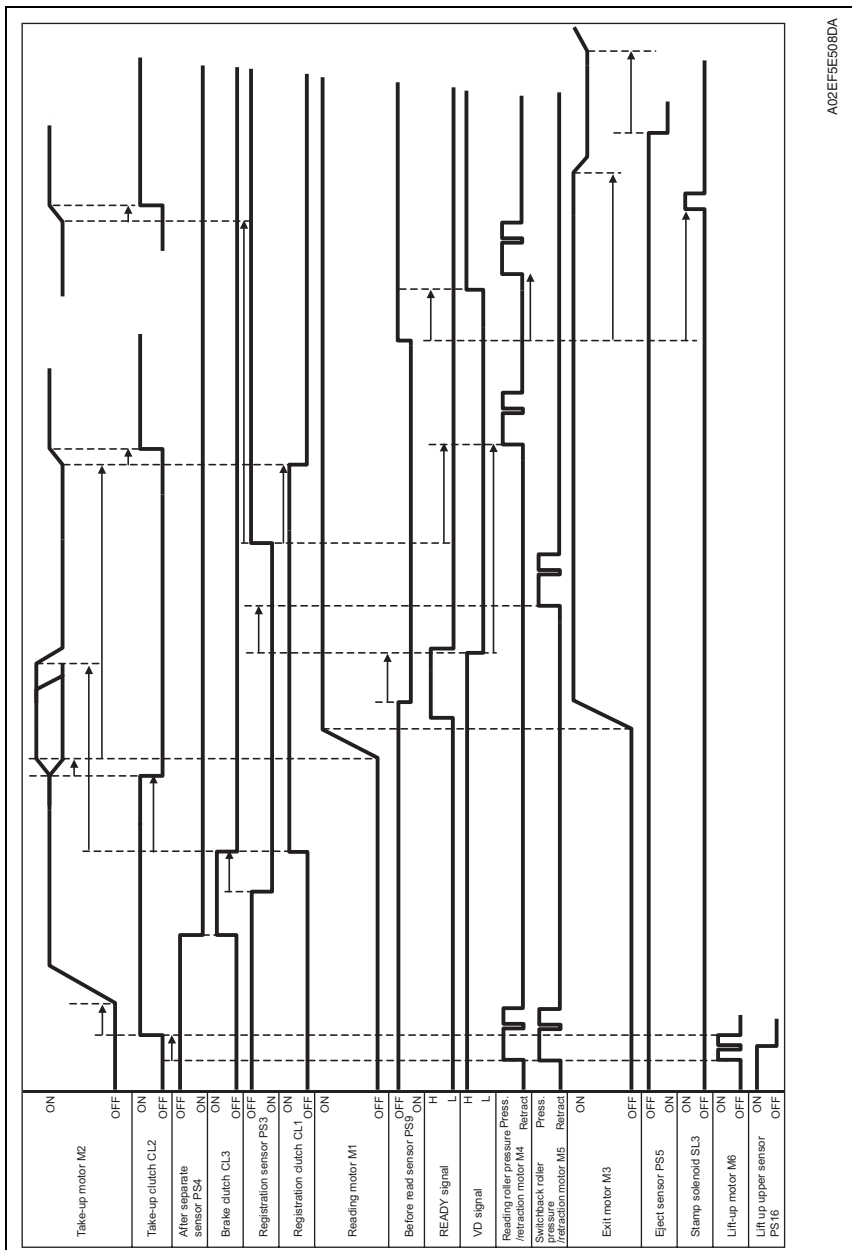



21.2.2 2-sided mode

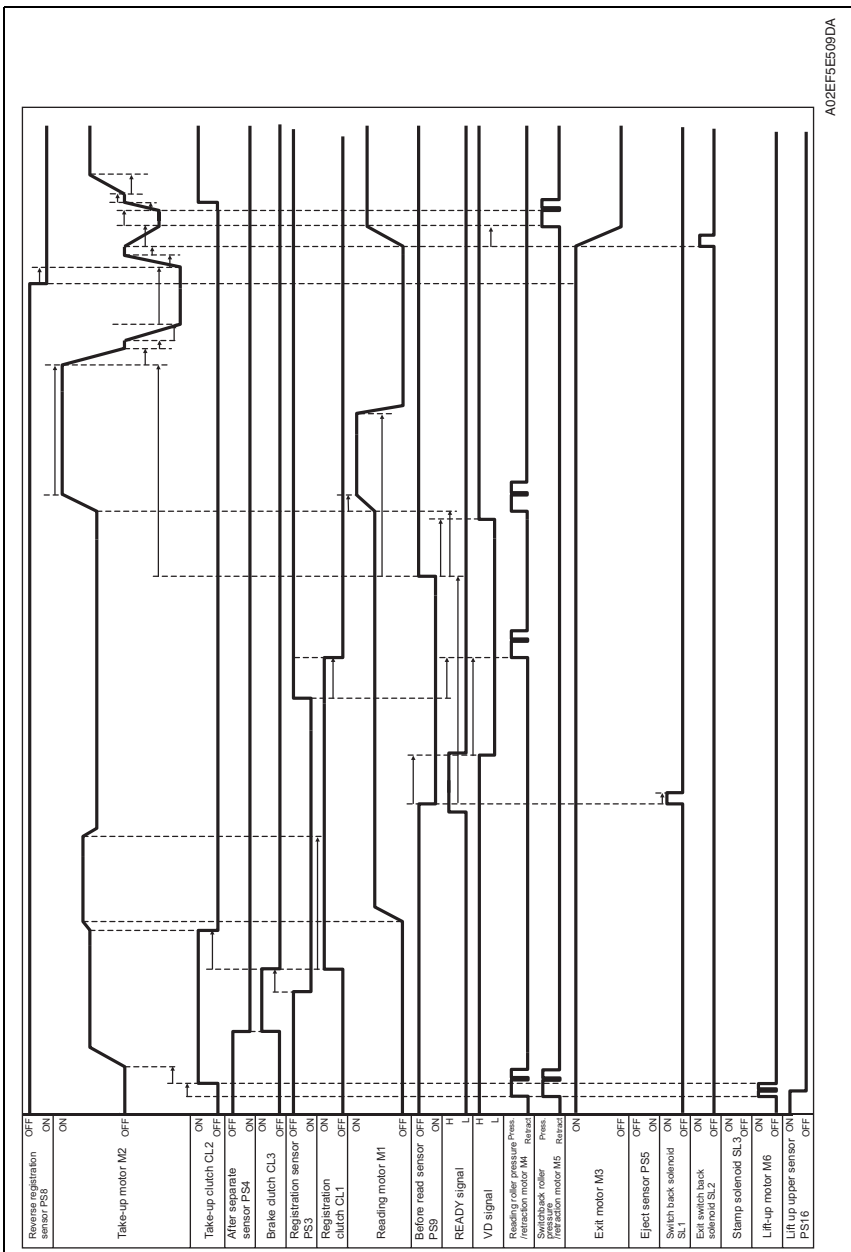

A02EF5E09DA

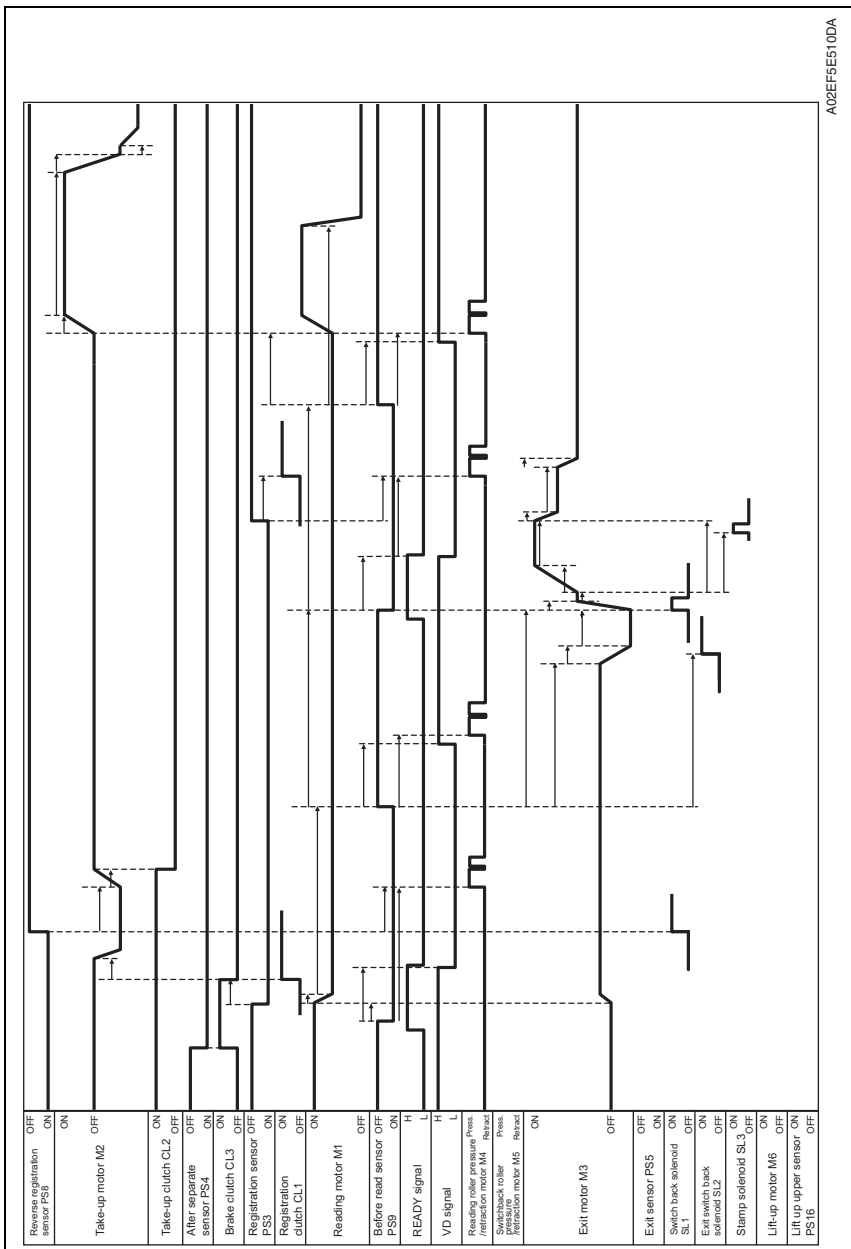

Blank Page



KONICA MINOLTA

**SERVICE MANUAL**

FIELD SERVICE

---

# **bizhub**

## **C353/C253/C203**

### **Standard controller**





# Revision history

After publication of this service manual, the parts and mechanism may be subject to change for improvement of their performance.

Therefore, the descriptions given in this service manual may not coincide with the actual machine.

When any change has been made to the descriptions in the service manual, a revised version will be issued with a revision mark added as required.



Revision mark:

- To indicate clearly a specific section revised within text,  is shown at the left margin of the corresponding revised section.  
The number inside  represents the number of times the revision has been made.
- To indicate clearly a specific page that contains a revision or revisions, the page number appearing at the left or right bottom of the specific page is marked with .  
The number inside  represents the number of times the revision has been made.

## NOTE

Revision marks shown in a page are restricted only to the latest ones with the old ones deleted.

- When a page revised in Ver. 2.0 has been changed in Ver. 3.0:  
The revision marks for Ver. 3.0 only are shown with those for Ver. 2.0 deleted.
- When a page revised in Ver. 2.0 has not been changed in Ver. 3.0:  
The revision marks for Ver. 2.0 are left as they are.

2008/01	3.0		Description addition of function enhanced version 2 firmware (Card Ver. 88)/Error corrections
2007/11	2.0		Description addition of function enhancement 1, error corrections
2007/07	1.0	—	Issue of the first edition
Date	Service manual Ver.	Revision mark	Descriptions of revision

# CONTENTS

## Standard controller

### General

1.	Controller specifications .....	1
1.1	Type .....	1
1.2	Supporting client specifications .....	2

### Maintenance

2.	Checking the controller firmware version .....	3
3.	Firmware upgrade .....	3
3.1	Outline .....	3
3.2	Notes about firmware rewrite .....	3
3.2.1	Types of firmware .....	3
3.2.2	Rewrite to/from a function enhanced version of firmware .....	3
3.3	Preparations for firmware rewriting by Windows Command Prompt .....	4
3.3.1	Service environment .....	4
3.3.2	Writing into the compact flash .....	4
3.4	Preparations for firmware rewriting by Firmware Imaging Toolkit 2006 .....	7
3.4.1	Correspond model .....	7
3.4.2	Function outline .....	7
3.4.3	System environment .....	7
3.4.4	Installation of software .....	8
3.4.5	Update of software .....	10
3.4.6	Screen .....	11
3.4.7	Details of each function .....	13
3.4.8	How to write firmware data .....	15
3.5	Firmware rewriting by compact flash .....	20
3.5.1	Updating method .....	20
3.5.2	Action when data transfer fails .....	22
3.6	Updating the firmware with the Internet ISW .....	23
3.6.1	Outline .....	23
3.6.2	Service environment .....	23
3.6.3	Preparations for firmware rewriting .....	23
3.6.4	Firmware rewriting .....	26
3.6.5	Error code list for the Internet ISW .....	28

# Troubleshooting

- 4. Checking the system configuration ..... 31
- 5. Status codes ..... 31
- 6. Troubleshooting procedures ..... 31
  - 6.1 Unable to print over the network..... 31
  - 6.2 Unable to transmit data through Scan to FTP..... 33
  - 6.3 Unable to transmit data through Scan to E-Mail..... 34
  - 6.4 E-mail does not reach the destination when transmission through Scan to E-Mail is completed. .... 34

Standard Controller

General

Maintenance

Troubleshooting

# General

## 1. Controller specifications

### 1.1 Type

Type	Built-in type controller	
Print speed	bizhub C353	35 prints/min (color/monochrome, A4, 1-sided)
	bizhub C253	25 prints/min (color/monochrome, A4, 1-sided)
	bizhub C203	20 prints/min (color/monochrome, A4, 1-sided)
First print time	bizhub C353	5.9 sec. or less (monochrome, A4)
	bizhub C253	7.7 sec. or less (monochrome, A4)
	bizhub C203	7.7 sec. or less (monochrome, A4)
Resolution	Data processing	600 x 600 dpi (print function, FAX function) 400 x 400 dpi (FAX function) 200 x 200 dpi (FAX function)
	Printing	Equivalent to 1800 dpi in main scanning direction x 600 dpi in sub scanning direction
Printer language	PCL5e/c emulation PCL XL Ver. 2.1 emulation PostScript 3 emulation (3016) XPS Ver. 1.0	
RAM	1024 MB	
Hard Disk	60 GB	
Host interface	Ethernet (10Base-T or 100Base-TX) USB 2.0/1.1	
Network protocol	TCP/IP(IPv4/IPv6), BOOTP, ARP, ICMP, DHCP, AutoIP, SLP, SNMP, FTP, LPR/LPD, RAW Socket, SMB over TCP/IP, IPP, HTTP, POP, SMTP, LDAP, NTP, SSL, IPX/SPX, AppleTalk, Bonjour, NetBEUI, WebDAV, WSD, S/MIME, IPsec, DNS, DynamicDNS	
Network print service	Pserver (NDS) ... NetWare 4.x, 5.x, 6.x Pserver (Bindery) ... NetWare 4.x NDPS ... NetWare 5.x, 6.x SMB, RAW port printing IPP 1.1 LPD	
Driver	PCL6 printer driver	<ul style="list-style-type: none"> <li>• Windows NT4.0 (SP6a or later)</li> <li>• Windows 2000 Professional (SP4 or later)</li> <li>• Windows XP Home Edition/Professional (SP2 or later)</li> <li>• Windows XP Professional x64</li> <li>• Windows Vista Home Basic /Home Premium /Ultimate /Business /Enterprise, Windows Vista Home Basic/ Home Premium /Ultimate /Business /Enterprise x64 edition</li> <li>• Windows Server 2003, Windows Server 2003 x64</li> </ul>
	PS3 printer driver	<ul style="list-style-type: none"> <li>• Windows 2000 Professional (SP4 or later)</li> <li>• Windows XP Home Edition/Professional (SP2 or later)</li> <li>• Windows XP Professional x64,</li> <li>• Windows Vista Home Basic /Home Premium /Ultimate /Business /Enterprise, Windows Vista Home Basic/ Home Premium /Ultimate /Business /Enterprise x64 edition</li> <li>• Windows Server 2003, Windows Server 2003 x64</li> </ul>





Driver	PostScript PPD driver	<ul style="list-style-type: none"> <li>• Macintosh OS 9.2 or later</li> <li>• Macintosh OS X 10.2/10.3/10.4</li> </ul>
	Fax driver	<ul style="list-style-type: none"> <li>• Windows NT4.0 (SP6a or later)</li> <li>• Windows 2000 Professional (SP4 or later)</li> <li>• Windows XP Home Edition/Professional (SP2 or later)</li> <li>• Windows XP Professional x64</li> <li>• Windows Vista Home Basic /Home Premium /Ultimate /Business /Enterprise, Windows Vista Home Basic /Home Premium /Ultimate /Business /Enterprise x64 edition</li> <li>• Windows Server 2003, Windows Server 2003 x64</li> </ul>
Utility	PageScope Web Connection	
Compatible paper size	Max. standard paper size A3 Wide (Long size paper: Width 210 mm to 297 mm x Length 457.3 mm to 1200 mm)	
Power requirements	Shared with Main body	
Operating environmental requirements	10 to 30° C (50 to 86° F) 15 to 85 %	
Fonts	PCL	Latin 80 fonts
	PS	Latin 137 fonts

## 1.2 Supporting client specifications

PC	IBM PC and its compatible, Macintosh		
OS	Server	Windows NT4.0 SP6/2000 SP3/2003 Server/2003 Server 64 bit/XP 64 bit	
	Client	Windows NT4.0 SP6/2000 SP3/XP/XP 64 bit Macintosh OS 9.2 or later, OS X 10.2, 10.3, 10.4 Macintosh OS 10.4 Intel	
Interface	With a network connection	Connection method	Ethernet 10Base-T/100Base-TX
		Protocols	TCP/IP, NetBEUI, IPX/SPX (NetWare 4.x, 5.x, 6.x)
	With a local connection	USB 2.0/1.1	
Browser	PageScope Web Connection Web browsers: Microsoft Internet Explorer 6 or later recommended (JavaScript enabled, Cookies enabled) Microsoft XML Parser MSXML3.X must be installed when using Internet Explorer 5.5. Netscape Navigator 7.02 or later (JavaScript enabled, Cookies enabled) Mozilla Firefox 1.0 or later (JavaScript enabled, Cookies enabled) Macromedia® Flash® (If "Flash" is selected in View Mode, version 7.0 or later plugin is required.)		

### NOTE

- These specifications are subject to change without notice.

# Maintenance

## 2. Checking the controller firmware version

- The version of the controller firmware can be checked on the Control panel of the machine.
  1. Call the Service Mode to the screen.
  2. Touch [Firmware Version].
  3. Check the firmware versions.

## 3. Firmware upgrade

### 3.1 Outline

- There are two ways to update the firmware: One is by directly connecting with the main body using the compact flash, and the other is by downloading over a network using the Internet ISW.

### 3.2 Notes about firmware rewrite

#### 3.2.1 Types of firmware

- Two types of firmware are released for bizhub C353/C253/C203. They are a maintenance release version and an enhanced version.
  - Maintenance release version : Addresses remaining problems
  - Function enhanced version : Adds new features and includes the contents of the maintenance release version available at the same time
- The function enhanced version firmware is available in two types: “Function Enhancement 1” and “Function Enhancement 2”
- Before rewriting a firmware, check the current firmware version of the machine and confirm the type of the current firmware using CSES.  
Select an appropriate firmware and rewrite the current firmware.

#### 3.2.2 Rewrite to/from a function enhanced version of firmware

- The processing that ensures compatibility is required when upgrading the firmware to the function enhanced version.
  - HDD Version Up (LK) : To maintain the compatibility of management information data and documents stored in HDD after the firmware upgrade. (only for Function Enhancement 2).

#### NOTE

- **Firmware can be rewritten only through the menu operation on the control panel and cannot be rewritten with the CS Remote Care system.**
- Take the following steps to perform processing that ensures compatibility.

**A. Upgrade to the function enhancement 2 from the early mass-production firm-ware/function enhancement 1**

1. After rewriting the firmware, turn OFF and ON the main power switch and sub power switch.
2. Trouble code C-E002 is displayed.
3. Call the Service Mode to the screen.
4. Touch [State Confirmation] → [Memory/HDD Adj.] → [HDD Version Up (LK)].
5. Check to see that the Start key is lit in blue. Touch the Start key to initiate version up.
6. When version up is completed, the result is displayed on the screen.
7. Turn OFF and ON the main power switch and sub power switch.

**3.3 Preparations for firmware rewriting by Windows Command Prompt**

**3.3.1 Service environment**

- OS: Windows 2000/XP
- Drive which enables writing/reading of compact flash
- Compact flash (service tool)

**3.3.2 Writing into the compact flash**

1. Put the data of firmware in the optional directory. (C:\bizhub in the below figure)

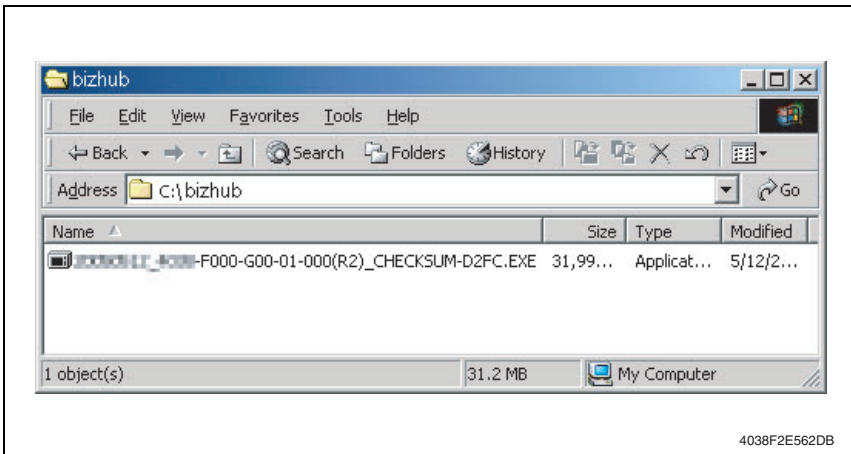

**NOTE**

- The file name of firmware data consists of the “Release Date\_Version\_CHECKSUM-\*\*\*\*.exe.”

- Double-click the firmware data, and specify the directory to be uncompressed, and then uncompress it.

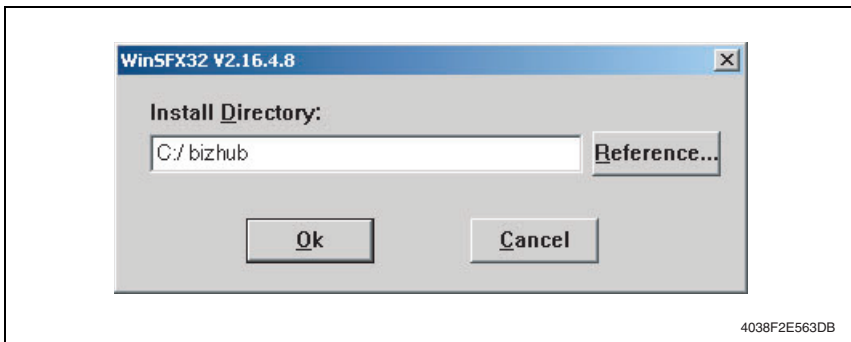

**NOTE**

- When old firmware is still left in the specified directory to be uncompressed, delete it before uncompressing.
- When the firmware data is decompressed, "card\_work" folder is created in the selected directory and the data is decompressed in this folder.

- Mount the compact flash on the PC, and check the drive name, which was recognized in the Windows. (F-drive in the following figure)

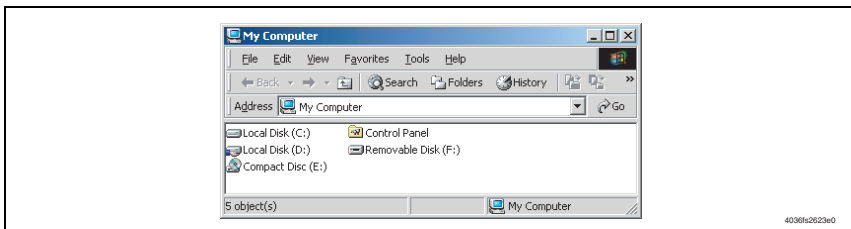

- Click [Start] → [Program] → [Accessories] → [Command Prompt] to open the command prompt.
- Use the command prompt to move into the uncompressed directory.
- Specify the drive of compact flash, which was recognized through the procedure 3, and execute the "mkcf.bat." (Input the C: \bizhub\card\_work>mkcf ## f (drive number): in the below figure, and push the "Enter".)

**NOTE**

- For ## within the above mkcf command, type two characters that correspond to the machine model on which firmware upgrading is made. Take a look at the following list to find right characters for a correct command.

Model and command list	
bizhub C353	t1
bizhub C253	t2
bizhub C203	t25

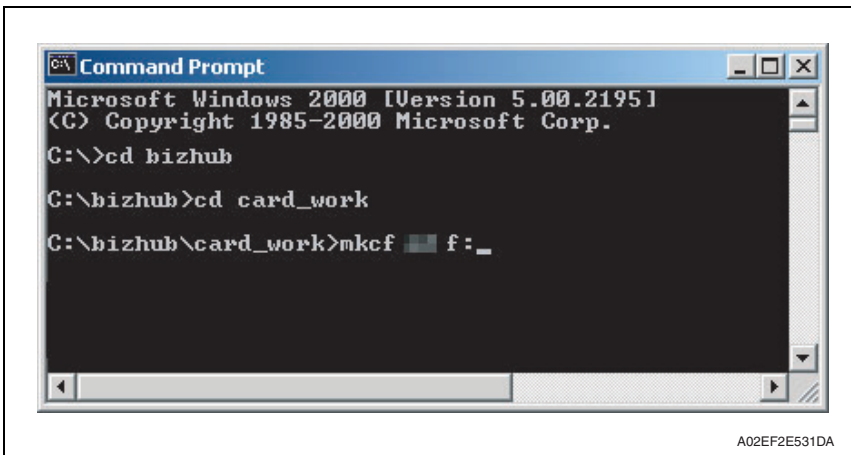

- 7. Once the “mkcf.bat” is executed, data writing into the compact flash is started.
- 8. Upon completion of writing, CHECKSUM is executed. If CHECKSUM value is precisely matched, “VERIFY OK” appears.

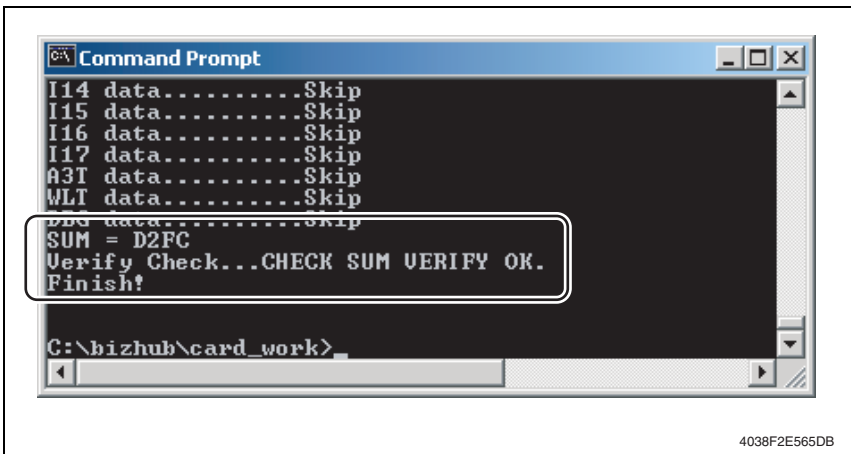

- 9. Remove the compact flash from PC.

**NOTE**

- When removing the compact flash, be sure to check if data is written as normal and then remove it according to the precise removing method.

### 3.4 Preparations for firmware rewriting by Firmware Imaging Toolkit 2006

- This software is designed as the tool to write firmware data of MFP/printer released by KMBT into the compact flash card.

#### 3.4.1 Correspond model

- Correspond models of the software is as follows.



Color machine	<ul style="list-style-type: none"> <li>• bizhub C650/C550/C451/C450/C353/C352/C351/C350/C300/C253/C250/C203</li> <li>• bizhub C450P/C353P/C352P/C250P</li> </ul>
B/W machine	<ul style="list-style-type: none"> <li>• bizhub 350/250/200</li> <li>• Di3510/3510f/3010/3010f/2510/2510f</li> </ul>

#### 3.4.2 Function outline

- The following functions are available with this software.

Function type	Function name	Description
Basic functions	Write Firmware to a card	<ul style="list-style-type: none"> <li>• Write firmware data into the compact flash card.</li> </ul> <a href="#">See P.13</a>
	Compare Firmware with a card	<ul style="list-style-type: none"> <li>• Compare the firmware data written into the compact flash card with the one saved in PC.</li> </ul> <a href="#">See P.13</a>
Advanced functions	Create a Firmware Image from a card	<ul style="list-style-type: none"> <li>• Create the firmware image form using the firmware data written into the compact flash card.</li> </ul> <a href="#">See P.14</a>
	Format a card	<ul style="list-style-type: none"> <li>• Format the compact flash card by the FAT or vxWorks form.</li> </ul> <p><b>NOTE</b></p> <ul style="list-style-type: none"> <li>• <b>vxWorks form is not applicable</b></li> </ul> <a href="#">See P.14</a>
	Display information about a card	<ul style="list-style-type: none"> <li>• Acquisition the information of firmware data written into the compact flash card.</li> </ul> <a href="#">See P.14</a>

#### 3.4.3 System environment

- The following system environments are required or recommended to use the software.

Computer	<ul style="list-style-type: none"> <li>• IBM PC/AT compatible machine</li> </ul>
CPU	<ul style="list-style-type: none"> <li>• Pentium III / 500 MHz or higher is recommended.</li> </ul>
Correspond OS	<ul style="list-style-type: none"> <li>• Windows 2000, Windows XP or Windows Server 2003</li> </ul>
Required memory	<ul style="list-style-type: none"> <li>• More than 128 MB (Windows 2000), 256MB (Windows XP/2003) is recommended.</li> </ul>
Others	<ul style="list-style-type: none"> <li>• Drive that is able to Read/Write compact flash</li> </ul>

### 3.4.4 Installation of software

- Follow the procedures shown below to install the software.

#### NOTE

- **Install the software to the PC with the administration authentication.**
- **When any anti-virus program is activated, quite the program before the installation.**

1. Double click [setup.exe] to start the installation of the software.



2. Click [Next >].

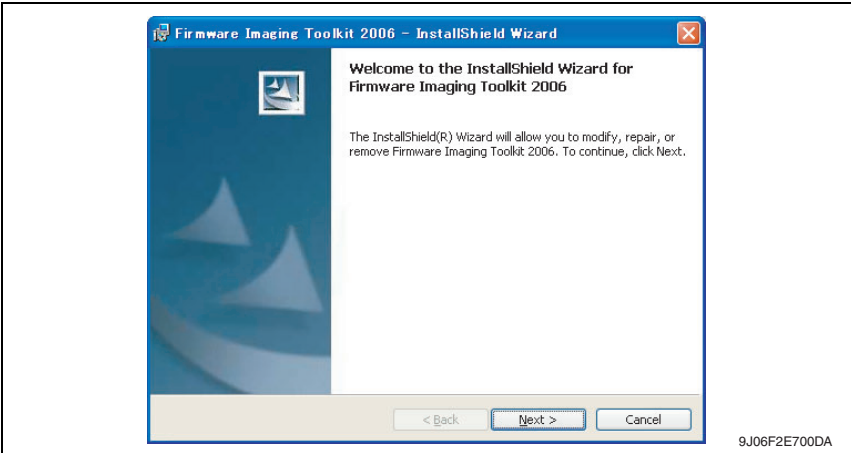

3. After checking the contents of license agreement, select [I accept the terms in the license agreement] and click [Next >].

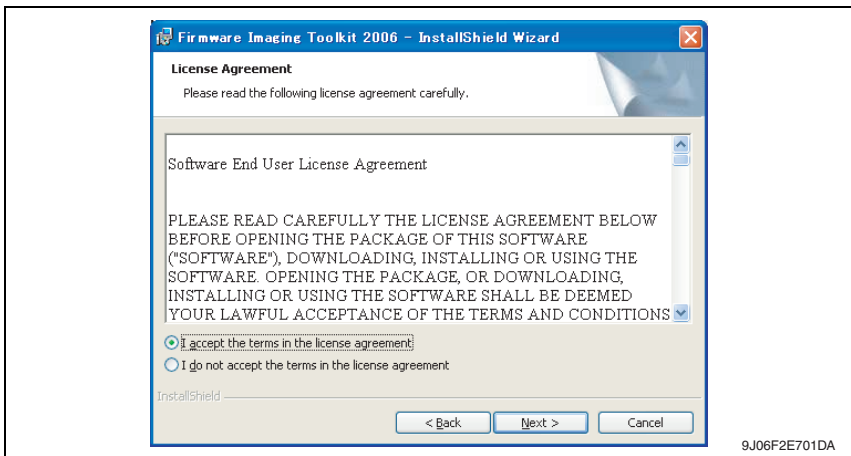

4. Select the installed destination folder of Firmware Imaging Toolkit 2006, and click [Next>].

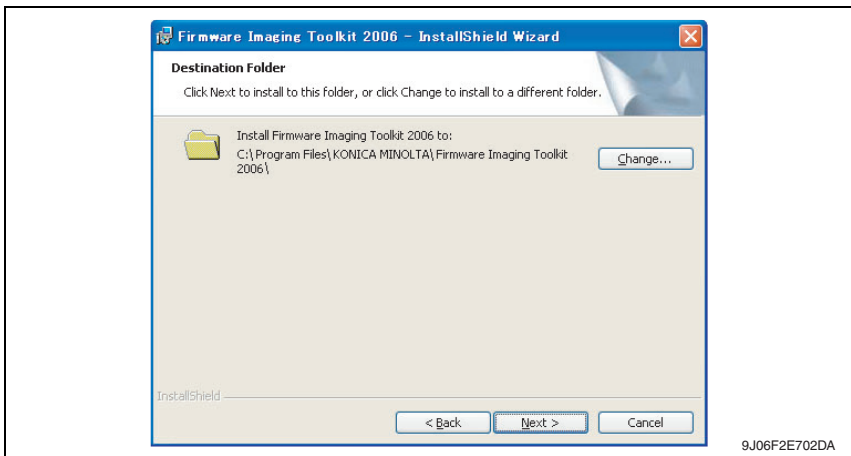



- 5. Click [Install] to start installation.
- 6. Click [Finish] to complete the installation.

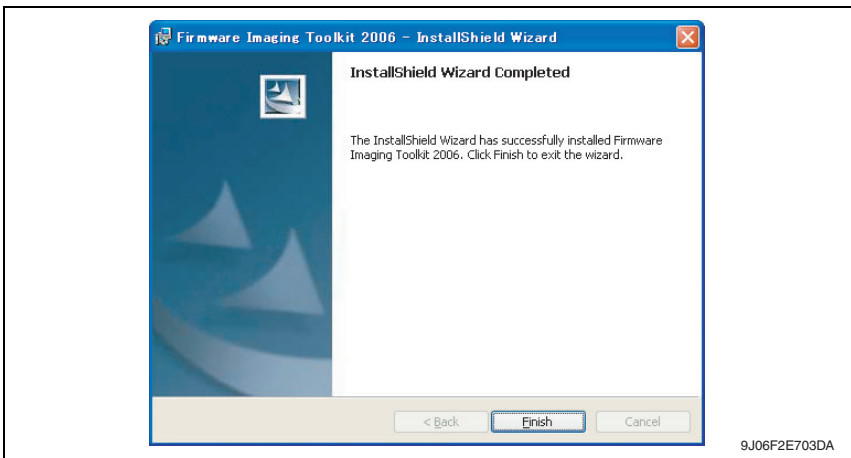

- 7. Shortcut file will be created inside Windows Start menu ([Program] → [KONICA MINOLTA] → [Firmware Imaging Toolkit 2006]).

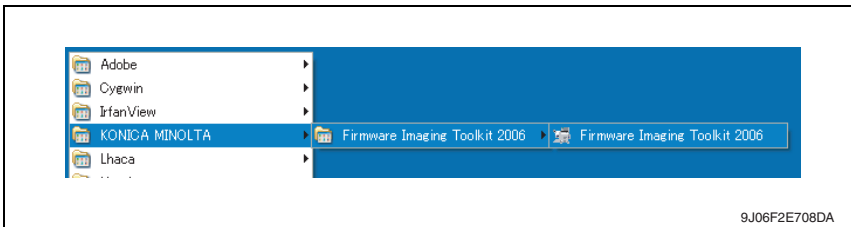

### 3.4.5 Update of software

- To update the software version, delete (uninstall) the currently installed program and install the new version.
  - Follow the procedures shown below to delete (uninstall) the program.
1. Quite the program if the software is activated.
  2. Select [Firmware Imaging Toolkit 2006] of [Add/Remove Programs] in Windows Control Panel menu to delete the program.

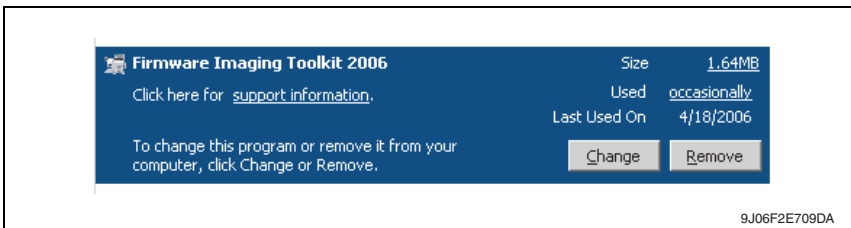

### 3.4.6 Screen

#### A. Main window

- The main window will be displayed after activating the software.
- Main window consists of 2 patterns: Basic mode, Advanced mode

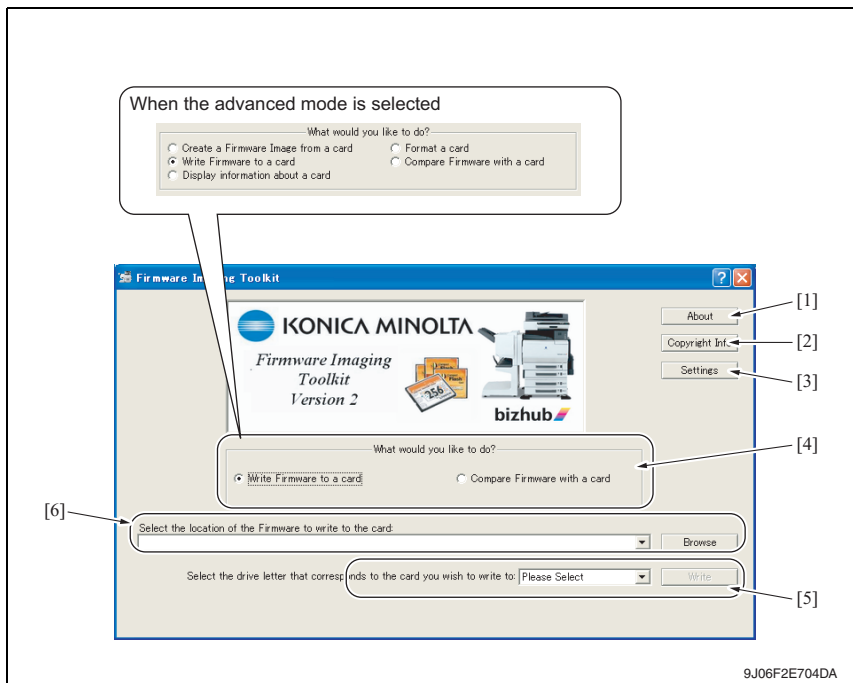

9J06F2E704DA

[1]	About	<ul style="list-style-type: none"> <li>• To display the outline of the tool.</li> </ul>
[2]	Copyright Info	<ul style="list-style-type: none"> <li>• To display the license agreement and version information of the tool.</li> </ul>
[3]	Settings	<ul style="list-style-type: none"> <li>• To display the dialog to enable the advanced functions.</li> <li>• Select the check box of [Enabled Advanced Features] to enable advanced functions at main window.</li> </ul> <p><a href="#">See P.12</a></p>
[4]	What would you like to do?	<ul style="list-style-type: none"> <li>• To select the function to be used.</li> <li>• Displayed screen is different between Basic mode and Advanced mode.</li> </ul> <p><a href="#">See P.13</a></p>
[5]	Select the location of the Firmware to write to the card:	<ul style="list-style-type: none"> <li>• To select the compact flash drive to which the data to write.</li> </ul>
[6]	Select the drive letter that corresponds to the card you wish to write to:	<ul style="list-style-type: none"> <li>• To select the location where the firmware is stored in PC.</li> </ul>

**B. Settings dialog**

- It will be displayed by clicking [Settings] at main window.
- Other settings will be enabled by selecting the check box of [Enabled Advanced Features].

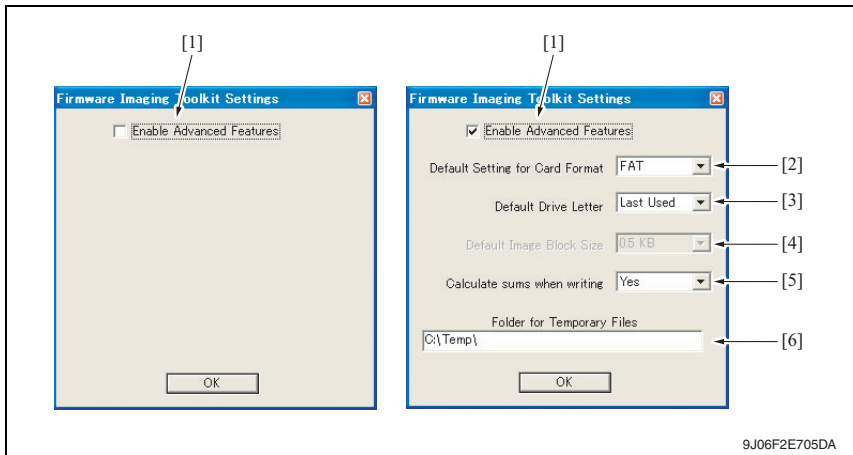

9J06F2E705DA

[1]	Enable Advanced Features	<ul style="list-style-type: none"> <li>• Enable the setting of advanced functions at the dialog by selecting the check box. Also advanced functions can be selected at the main window.</li> </ul>
[2]	Default Setting for Card Format	<ul style="list-style-type: none"> <li>• Select the default card format during software starting.                      FAT : The format to be used by all models that the software supports.                      vxWorks : Not available yet.</li> </ul>
[3]	Default Drive Letter	<ul style="list-style-type: none"> <li>• Select how to set default of compact flash drive during software starting.                      LastUsed : The drive used at previous time is selected.                      None : [Please Select] is displayed on the screen every starting and the drive should be selected every time.</li> </ul>
[4]	Default Image Block Size	<ul style="list-style-type: none"> <li>• Not available yet.</li> </ul>
[5]	Calculate sums when writing	<ul style="list-style-type: none"> <li>• Set whether to calculate check sums during data writing.</li> <li>• If [YES] is selected, data consistency can be ensured by data verification of check sums during data writing. However, it takes more time for data writing compared to the case without sums calculation (Basically this mode shall be selected.)</li> <li>• If [No] is selected, check sums calculation is skipped during data writing. Although it take less time for data writing compared to the case with sums calculation, it fails to ensure the reliability of the written data.</li> </ul>
[6]	Folder for Temporary Files	<ul style="list-style-type: none"> <li>• Set the folder for saving temporary files during the tool is activating. The temporary file is automatically deleted after the operation completes normally.</li> </ul>

### 3.4.7 Details of each function

#### A. Basic functions

##### (1) Write Firmware to a card

- To write FW data into the compact flash. The FW data of the models shown below can be written.
- To write FW data into the compact flash. The FW data of the models shown below can be written.

<Corresponding models and firmware file type>



Models	File type	Indexed firmware type	Compressed firmware type	Uncompressed firmware type	Di3510/350/250/200 firmware type
C650		Mosel1_cf.tar.gz	*.img.gz	*.img	—
C550		Mosel2_cf.tar.gz			—
C451		Mosel3_cf.tar.gz			—
C353/C353P		thames1_cf.tar.gz			—
C253		thames2_cf.tar.gz			—
C203		thames25_cf.tar.gz			—
C450/C450P/C351		rhein1_cf.tar.gz			—
C352/C352P/C300		rhein2_cf.tar.gz			—
C350		tss2_cf.tar.gz			—
C250/C250P		rhein3_cf.tar.gz			—
Di3510/3510f/3010/3010f/2510/2510f		—	—	—	ma001
350/250/200		—	—	—	ma001a

#### NOTE



- **The above-mentioned [Indexed firmware type] and [Di3510/350/250/200 firmware type] shall be comprised of multiple files and one of the files shall be named as above.**
- **[Compressed firmware type] means the compressed formed image file that is created using the tool's function of the [Create a Firmware Image from a card].**
- **[Uncompressed firmware type] means the image file that is uncompressed the compressed firmware file.**
- **To write the image file data (\*.img.gz or \*.img) into the compact flash, use the compact flash with the same capacity as the one used for the original image file. Although the compact flash with larger capacity than the original one can be used, it is not covered under warranty.**
- **C350 firmware requires the compact flash over 64 MB.**
- **Firmware of C650/C550/C451/C450/C450P/C353P/C353/C352/C352P/C351/C300/C253/C250/C250P/C203 requires the compact flash over 128 MB.**

##### (2) Compare Firmware with a card

- Compare the firmware data written into the compact flash and the one (file) saved in PC.
- After the comparison, display the check sum information (comparison result dialog) of the firmware data of the compact flash and the file.
- The firmware data (file) format saved in PC shall consistent with the one written into the compact flash.

**B. Advanced functions****(1) Create a Firmware Image from a card**

- Create the image file from the firmware data written into the compact flash.  
Create the image file by dumping directly the data in the card. This function allows us to save the various type of firmware data in the compact flash as the image file and hold as copy data.
- The created FW image file is automatically compressed and created as the Compressed firmware file (\*.img.gz).

The image file is written into the compact flash in the uncompressed form, however, the uncompressed data would occupy too much capacity, which makes file control difficult. Therefore this tool doesn't create uncompressed firmware file (\*.img).

**(2) Format a card**

- Make format of the compact flash in FAT or vxWork form.
- To write the firmware data into the compact flash, the card should be formatted in FAT form to clear (initialize) the description of the compact flash.

**NOTE**

- **In current version, only FAT format is available but not vxWork format.**
- **After the firmware data is written into the compact flash, it becomes the own file style that is different from the FAT, and the compact flash that the firmware data is written cannot be browsed on the Windows OS.**

**(3) Display information about a card**

- Display the information of the firmware data written into the compact flash.  
The information to be displayed is according to the type of written FW data.
- For the series of Di3510/200/250/350 series, MSC version is displayed.
- ⚠ For the series of C650/C550/C451/C450/C450P/C353/C353P/C352/C352P/C351/C350/C300/C253/C250/C250P/C203, check sums of each firmware data is displayed.

### 3.4.8 How to write firmware data

#### A. In the case of C650/C550/C451/C450/C450P/C353/C353P/C352/C352P/C351/C350/C300/C253/C250/C250P/C203 series

1. Put the firmware data in the optional directory. (C:\bizhub in the below figure)

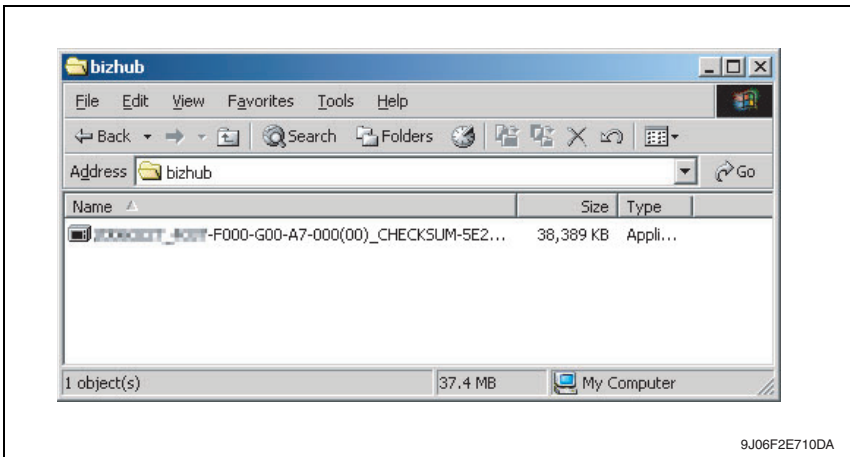

9J06F2E710DA

#### NOTE

- The file name of firmware data consists of the “Release Date\_Version\_CHECKSUM-\*\*\*\*.exe.”
2. Double-click the firmware data, and specify the directory to be uncompressed, and then uncompress it.

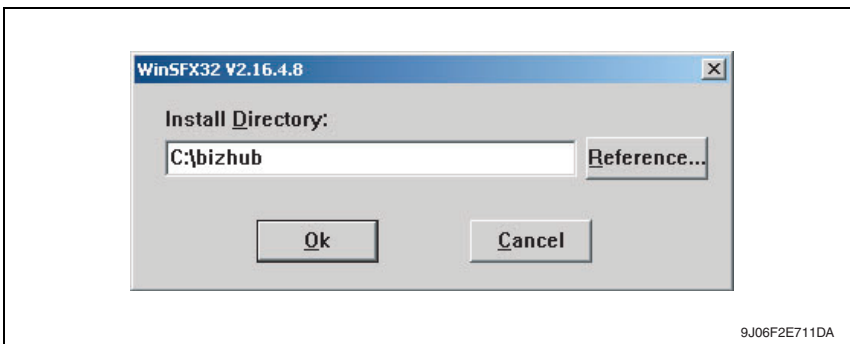

9J06F2E711DA

#### NOTE

- When old firmware is still left in the specified directory to be uncompressed, delete it before uncompressing.

- 3. Mount the compact flash on the PC, and check the drive name, which was recognized in the Windows. (F-drive in the following figure)

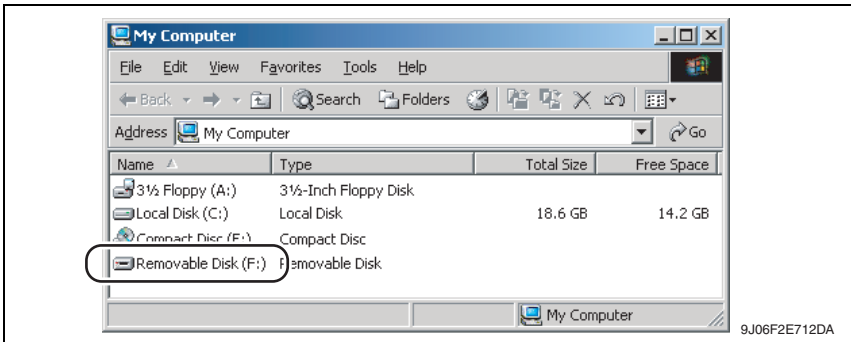

- 4. Start Firmware Imaging Toolkit 2006.

**NOTE**

- When using the external compact flash drive such as USB be sure to connect them before starting this tool.

- 5. Select the check box of [Write Firmware to a card].

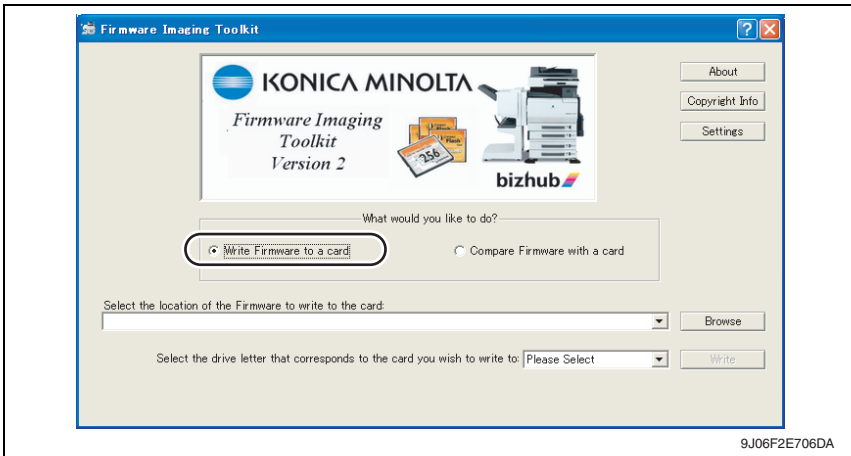

6. Click [Browse].

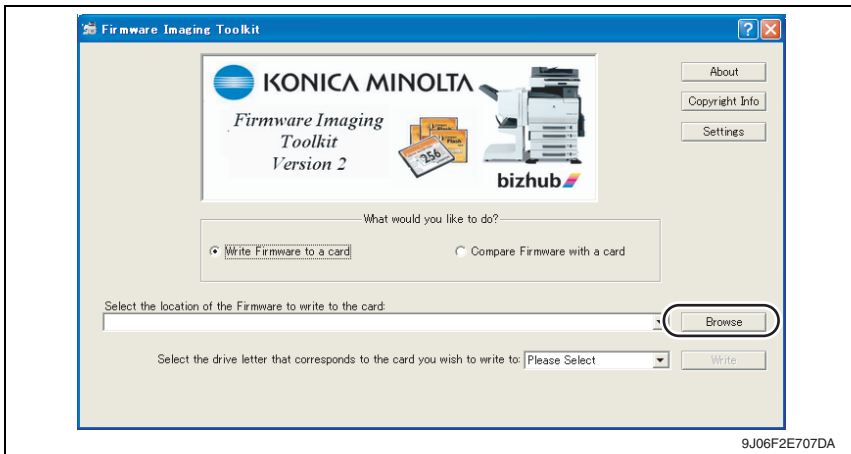

7. Select the file type [C353/C253/C203 Indexed Firmware].

8. Move to the folder decompressed at step 2, confirm that only "###\_cf.tar.gz" (### is for model name) is displayed, and select.

**NOTE**

- If the file extension is set to be not displayed in Windows, the file name “.gz” will not be displayed.

9. Click [Open].

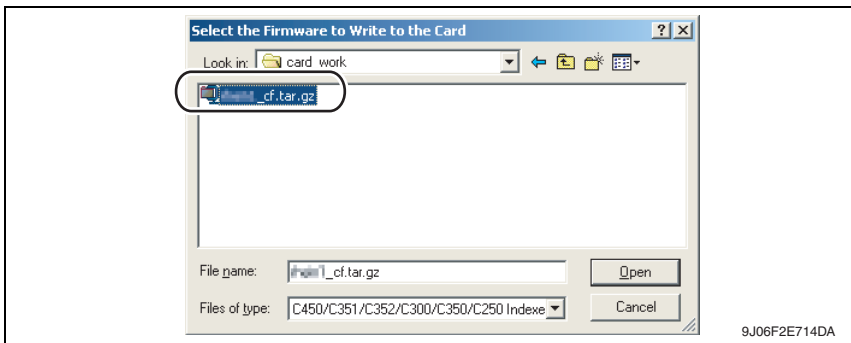



10. Select the drive that the compact flash is inserted, which is confirmed at step 3.

**NOTE**

- The drives other than the compact flash that is recognized as “Removable Disk” can be selected for the writing destination. If these drives are selected mistakenly to make the writing, it may give fatal damage on Windows system or delete the saved data. Therefore pay close attention when selecting the drive.

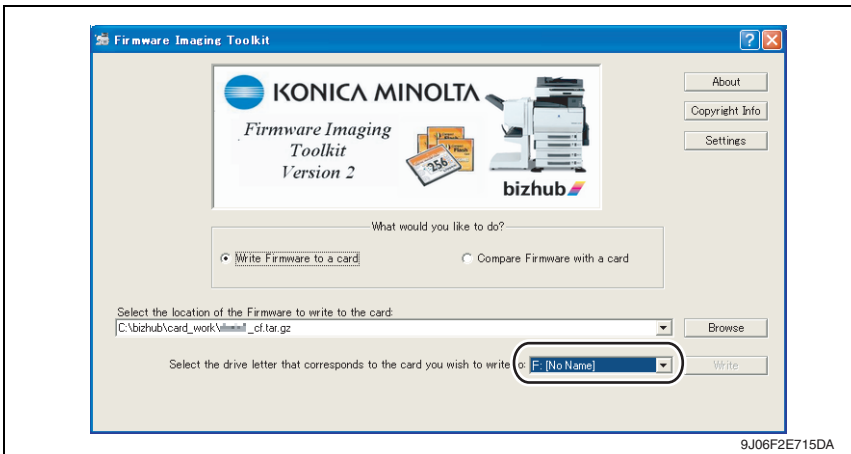

11. [Write] button is changed from gray into active status.

When clicking [Write] button, the following dialog is displayed.

12. In the dialog, re-confirm the firmware data and the written destination drive, and click [YES].

(If [NO] is clicked, the screen goes back of the main window.)

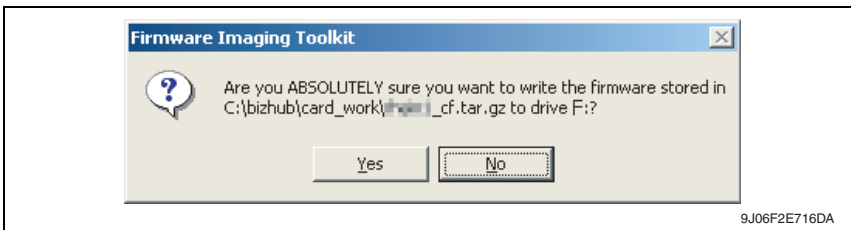

13. Click [Yes], and data writing starts.

**NOTE**

- **Writing a card is a resource intensive operation for your computer - do not attempt to multitask (use the computer for anything else) during the writing procedure.**

14. When the writing is completed, the following screen appears.

In this screen, check sums will be compared between the firmware data and one written into the compact flash.

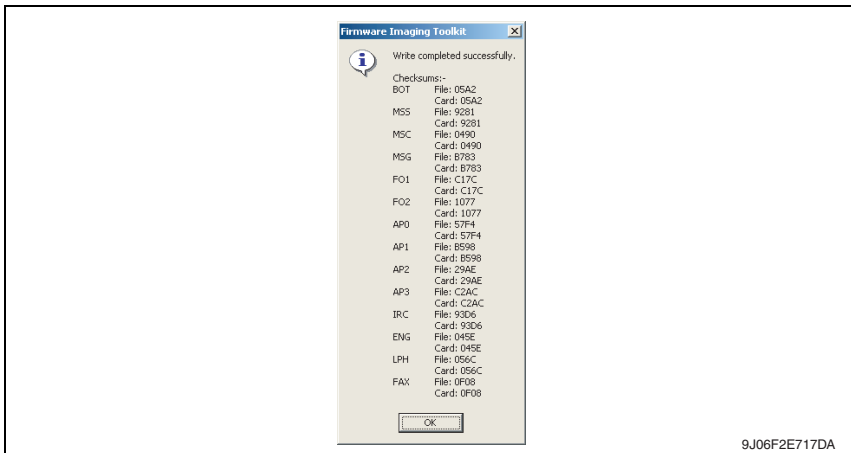

**NOTE**

- **The contents displayed on the screen may differ according to the model type. The above is the screen displayed for firmware data writing of bizhub C450.**

15. Confirm each check sums are identical and quit Firmware Imaging Toolkit 2006.

16. Take out the compact flash from the PC.

**NOTE**

- **When removing the compact flash, be sure to check if data is written as normal and then remove it according to the precise removing method.**

### 3.5 Firmware rewriting by compact flash

- The firmware is updated using the compact flash.

#### 3.5.1 Updating method

##### NOTE

- **NEVER** remove or insert the compact flash card with the machine power turned ON.

1. Turn OFF the main power switch.
2. Open the rear right door.

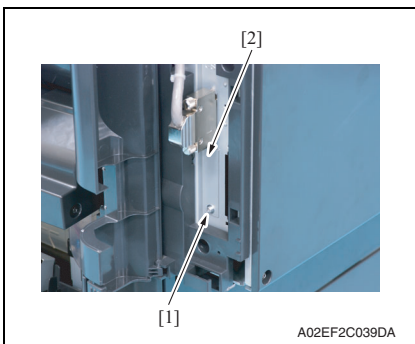

3. Remove the screw [1] and the metal blanking plate [2].

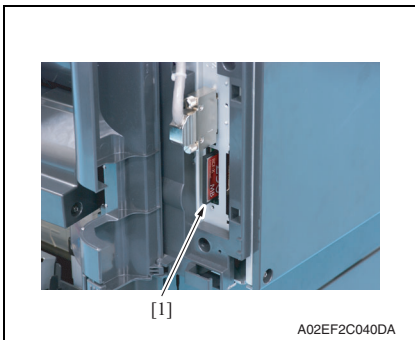

4. Insert the compact flash card [1] into the slot.

5. Turn ON the main power switch and the sub power switch.
6. Control panel shows F/W items to be updated.

7. Select the particular type of F/W to be updated. (Select [YES].)

**Firmware Update**    Please do not turn off the main SW and Sub-Power !!

---

<p><b>MFP CONTROLLER</b></p> <p><input type="checkbox"/> YES    <input type="checkbox"/> NO</p> <p><b>SCANNER</b></p> <p><input type="checkbox"/> YES    <input type="checkbox"/> NO</p> <p><b>PRINTER</b></p> <p><input type="checkbox"/> YES    <input type="checkbox"/> NO</p> <p><b>FAX BOARD CONTROLLER1</b></p> <p><input type="checkbox"/> YES    <input type="checkbox"/> NO</p>	<p><b>FAX BOARD CONTROLLER2</b></p> <p><input type="checkbox"/> YES    <input type="checkbox"/> NO</p> <p><b>ADF(DF-M)</b></p> <p><input type="checkbox"/> YES    <input type="checkbox"/> NO</p> <p><b>FINISHER</b></p> <p><input type="checkbox"/> YES    <input type="checkbox"/> NO</p> <p style="text-align: right;"><input type="button" value="START"/></p>
--	--

A02EF2C522DA

F/W to be updated	Appropriate board
MFP CONTROLLER	MFP board (MFPB)
SCANNER	Image processing board (IPB)
PRINTER	Printer control board (PRCB)
FAX BOARD CONTROLLER1	Fax board (Main) *1
FAX BOARD CONTROLLER2	Fax board (Sub) *2
ADF (DF-M)	DF control board (DFCB)
FINISHER	FS control board (FSCB) *3

\*1: The optional fax kit is necessary for the above procedure.

\*2: The optional fax multi line ML-501 is necessary for the above procedure.

\*3: The optional finisher FS-519 or FS-609 is necessary for the above procedure.

8. Press the [START]. (At this time, the Start key starts blinking red.)
9. Check that the control panel shows the message indicating that the data has been rewritten correctly ([Downloading Completed]). Check also the check sum value ([Check Sum #####]) shown on the control panel. (The Start key blinks blue.)
10. Turn OFF the main power switch.
11. Remove the compact flash card from the slot.
12. Turn ON the main power switch, and close the front door.

**NOTE**

- When turning the main power switch ON for the first time after the firmware is updated, data may sometimes be internally updated. In that case, the following message will be displayed. Never turn the main power switch OFF until either the serial number input screen or the trouble code screen is displayed.

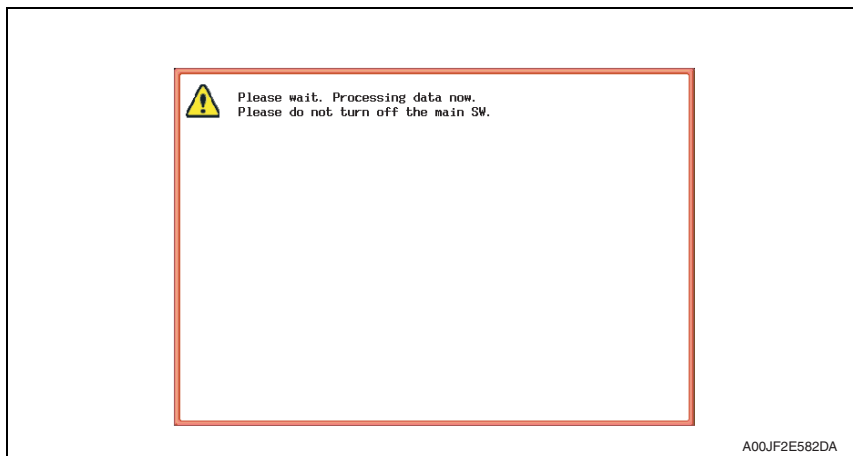

13. Call the Service Mode to the screen.
14. Select [Firmware Version].
15. Make sure if the version of firmware is updated.

**3.5.2 Action when data transfer fails**

- If “NG” appears on the control panel, indicating that rewriting has been unsuccessful (in which case the Start key lights up red), take the following steps.
  1. Perform the data rewriting procedure again.
  2. If the procedure is abnormally terminated, change the compact flash for a new one and try another rewriting sequence.
  3. If the procedure is still abnormally terminated, change the board that has caused “NG” and carry out data rewriting procedure.

MFP CONTROLLER	MFP board (MFPB)
SCANNER	Image processing board (IPB)
PRINTER	Printer control board (PRCB)
FAX BOARD CONTROLLER1	Fax board (Main) *1
FAX BOARD CONTROLLER2	Fax board (Sub) *2
ADF (DF-M)	DF control board (DFCB)
FINISHER	FS control board (FSCB) *3

\*1: The optional fax kit is necessary for the above procedure.

\*2: The optional fax multi line ML-501 is necessary for the above procedure.

 \*3: The optional finisher FS-519 or FS-609 is necessary for the above procedure.

### 3.6 Updating the firmware with the Internet ISW

#### 3.6.1 Outline

- [Internet ISW] is the system which gives the instruction for updating the firmware with the control panel of the main body, so the main body will automatically receive the firmware from the program server over a network for updating. With the Internet ISW, the firmware can be updated when the CE is at the user's without firmware data.

#### 3.6.2 Service environment

The following conditions are necessary for using the Internet ISW function.

- The main body is connected to such a network environment that the firmware can be downloaded on the internet using the ftp or http protocol.

The "Internet ISW" will not operate under the following conditions.

- Main power switch is set to OFF.
- Sub power switch is set to OFF.
- When the following setting is set to "ON":  
[Administrator Setting] → [Security Setting] → [Enhanced Security Mode]
- The main body has the job currently performing.

#### 3.6.3 Preparations for firmware rewriting

- For using the Internet ISW, the network parameter, program server address as well as firewall address need to be set to the main body.
- For details of each setting item, refer to Adjustment/Setting "Internet ISW".  
[See P.432 of the main body service manual.](#)

#### A. Internet ISW Set

1. Call the Service Mode to the screen.
2. Touch [Internet ISW Set] which is available from [Internet ISW].

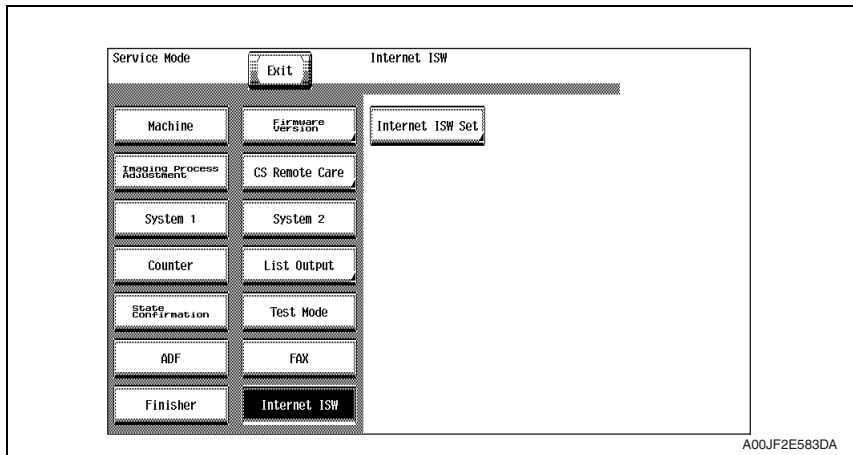

- 3. Touch [ON], and touch [END].

**NOTE**

- **Settings such as server setting, etc. will be available by selecting “ON” on this setting.**
- **When the following setting is set to “ON”, “ON” cannot be selected on this setting. [Administrator Setting] → [Security Setting] → [Enhanced Security Mode]**

**B. Protocol setting**

- **It performs the setting concerning the protocol (ftp or http) for connecting to the Internet ISW.**
- **When connecting to the program server using a proxy server, perform the setting for a proxy server.**

Step	Connecting by http	Connecting by ftp
0	Select [Internet ISW] which is available from [Service Mode].	
1	Data Input Setting • Touch [HTTP Setting], and select [ON].	Data Input Setting • Touch [FTP Setting], and select [ON].
2	Connect Proxy • For connecting via proxy server, select [ON].	
3	Proxy Server • For connecting via proxy server, set the proxy server address and the port number.  1. Select the [Server Address], and set the proxy server address by IP addressing scheme or FQDN scheme. 2. Select [Port Number], and set the port number for the proxy server from 1 through 65535.	
4	Proxy Authentication • Set the login name and the password which may be necessary for authentication when accessing to the proxy server.  1. When Authentication is necessary for accessing to the proxy server, select [Authentication], and select [ON]. 2. Select [Log-in Name], and enter the login name on the on-screen keyboard. 3. Select [Password], and enter the password on the on-screen keyboard.	Connection Setting • Perform the setting for accessing FTP server.  1. Select [Port Number], and set the port number for FTP server from 1 through 65535. 2. Select [Connection Time Out], and set the time for the connection time out from 1 through 60. 3. When connecting in PASV mode, select [PASV Mode], and select [ON].  *PASV Mode: This mode is for transferring the file with FTP under the condition where communication is restricted such as inside the firewall. Since with PASV mode, the client with restriction sets the port number, data transmission port can be secured to enable the file transmission.
5	Connection Time-Out • Select [Connection Time-Out], and set the time for the connection time out between 30 and 300 seconds.	—





### 3.6.4 Firmware rewriting

#### NOTE

- When performing the Internet ISW, ask the administrator for permission beforehand.
- DO NOT turn OFF the main/sub power switch while downloading.

#### A. Conducting rewriting on the control panel.

1. Perform the following setting.  
[Service Mode] → [Internet ISW] → [Download]
2. Touch [ISW Start].

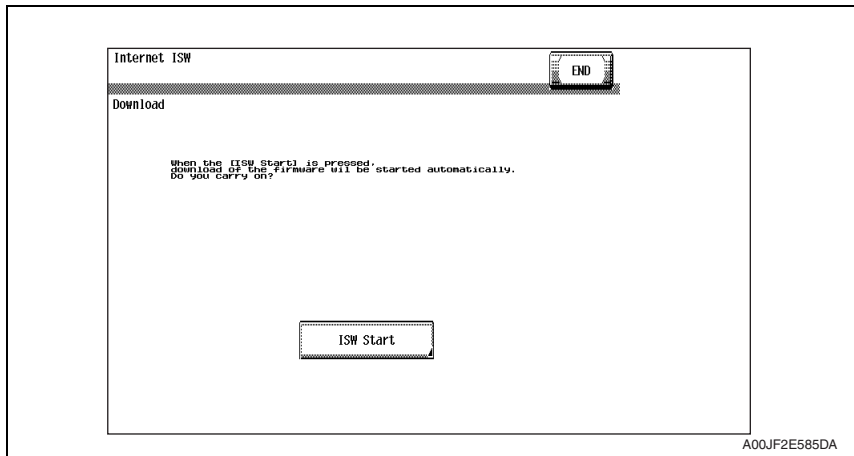

3. The main body will automatically start running, and it starts accessing the server.
4. Select the F/W to be updated, and start downloading.

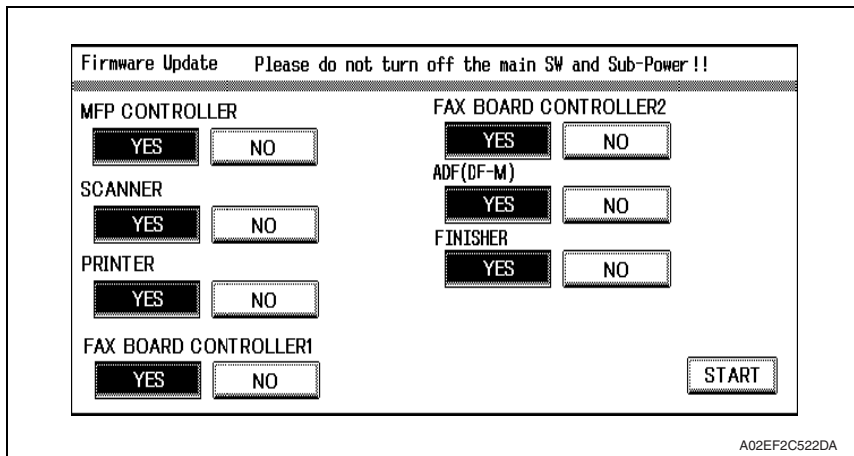

#### B. During firmware updating

1. The message to indicate the status will be displayed on the screen while connecting or transferring data.

**C. Completed or failed****(1) Firmware updated normally**

1. When the Firmware is normally updated, restart the main body in auto or manual mode to display the outcome, and touch [OK] to return to the main screen.

**(2) Failing to update the firmware due to the network trouble**

1. When updating failed to complete due to the trouble on connecting to the network, an error code and the message will be displayed.
2. Restart the main body in auto or manual mode, and touch [OK]. It can be used with the firmware version before conducting updating.
3. Check the settings for the network by error codes, and try updating again.

**NOTE**

- **For error codes, refer to “Error code list for the Internet ISW”.**

[See P.28](#)

**(3) Failing to update the firmware after downloading has started**

1. Once firmware updating has started, the ROM in the main body will be deleted.  
When it failed right after updating has started, restart the main body, and shift to the standby screen to retry downloading.
2. When updating on the control panel, touch [settings] on the standby screen, and check the Network settings again.  
Touch [Download], and restart the Internet ISW.

**NOTE**

- **Return to the standby screen without fail after turning the main power switch OFF/ ON if the firmware is not updated.**
- **Firmware can be updated with the Compact flash with the main power switch OFF.**

**D. Confirming the firmware version**

1. Call the Service Mode to the screen.
2. Select the [Firmware Version].
3. Check if the firmware version is updated.

**3.6.5 Error code list for the Internet ISW**

- When a trouble occurred while conducting the Internet ISW and it was not normally connected, the message on the status and the error code will be displayed on the control panel.  
When updating with CS Remote Care, the error code will be sent to the CS Remote Care center.

<Sample display>

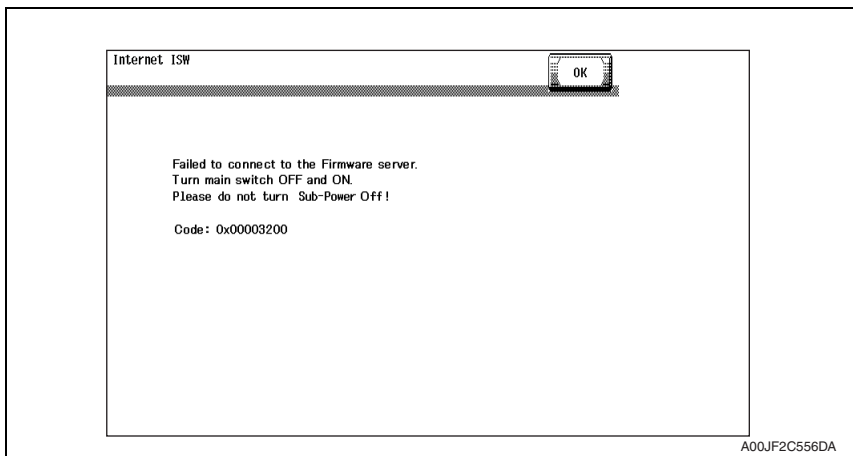

Error code	Description	Countermeasure
Control panel		
0x00000001	Illegal error on the control	<ul style="list-style-type: none"> <li>• Check if the following setting is set to "Valid". [Service Mode] → [Internet ISW] → [Internet ISW setting]</li> <li>• Check the status of the following setting. [Service Mode] → [Internet ISW] → [Transfer access setting]</li> <li>• If the above process does not solve the problem, inform the corresponding error code to the KONICA MINOLTA.</li> </ul>
0x00000010	Parameter error	<ul style="list-style-type: none"> <li>• Check if the following setting is set to "Valid". [Service Mode] → [Internet ISW] → [Internet ISW setting]</li> <li>• If the above process does not solve the problem, inform the corresponding error code to KONICA MINOLTA.</li> </ul>

Error code	Description	Countermeasure
Control panel		
0x00111000	Error concerning the network • Connection has been completed.	<ul style="list-style-type: none"> <li>• Check the User's network environment. (LAN cable's connection)</li> <li>• Check the status of the following setting. [Service Mode] → [Internet ISW] → [Transfer access setting]</li> <li>• Check to see if the FTP server operates normally.</li> </ul>
0x00111001	Error concerning the network • It cannot be connected to the server.	<ul style="list-style-type: none"> <li>• Check the network environment of the User.</li> <li>• Check to see if the FTP server operates normally.</li> </ul>
0x00111100	Error concerning the network • Communication timeout.	
0x00111101	Error concerning the network • Disconnection occurred	<ul style="list-style-type: none"> <li>• Check the network environment of the User.</li> <li>• Check to see if the FTP server operates normally.</li> </ul>
0x00111110	Error concerning the network • The network is not connected.	
0x00110010	Error concerning the network • Others	
0x00001###	FTP error • Reply code when it failed to be connected	<ul style="list-style-type: none"> <li>• Check to see if FTP server normally operates.</li> <li>• Check the IP address, user's name, etc.</li> </ul>
0x00002###	FTP error • Error reply code for the user command or pass command	<ul style="list-style-type: none"> <li>• Check to see if FTP server operates normally.</li> </ul>
0x00003###	FTP error • Error reply code for CWD command	
0x00004###	FTP error • Error reply code for the TYPE command.	<ul style="list-style-type: none"> <li>• Check to see if FTP server operates normally.</li> </ul>
0x00005###	FTP error • Error reply code for the PORT command.	
0x00006###	FTP error • Error reply code for the PASV command.	<ul style="list-style-type: none"> <li>• Check to see if FTP server operates normally.</li> <li>• Set the PASV mode to "Invalid", and try it again.</li> </ul>
0x00007###	FTP error • Error reply code for the RETR command.	<ul style="list-style-type: none"> <li>• Check to see if FTP server operates normally.</li> <li>• Wait for about 30 minutes and try it again.</li> </ul>
0x1000 0100	<ul style="list-style-type: none"> <li>• It cannot be accepted because of the job currently being executed.</li> <li>• ISW being executed by other method.</li> </ul>	<ul style="list-style-type: none"> <li>• Wait for the current job to be completed and try it again.</li> </ul>
0x10000101	<ul style="list-style-type: none"> <li>• It cannot be accepted because the sub power switch is OFF.</li> </ul>	<ul style="list-style-type: none"> <li>• Turn sub power switch ON and try it again.</li> </ul>
0x10000102	<ul style="list-style-type: none"> <li>• The Internet ISW is already being executed.</li> </ul>	<ul style="list-style-type: none"> <li>• Wait for the current Internet ISW to be completed.</li> </ul>

Error code	Description	Countermeasure
Control panel		
0x10000103	<ul style="list-style-type: none"> <li>It failed to prohibit the job. (It failed to lock the operation.) → It failed to lock the job because the operation is already locked with PSWC, etc.</li> </ul>	<ul style="list-style-type: none"> <li>Check if the following setting is set to "Valid". [Service Mode] → [Internet ISW] → [Internet ISW setting]</li> <li>If the above process does not solve the problem, inform the corresponding error code to the KONICA MINOLTA.</li> </ul>
0x10000104	<ul style="list-style-type: none"> <li>There is no space for F/W data to be downloaded.</li> </ul>	
0x10000106	<ul style="list-style-type: none"> <li>Check sum error</li> </ul>	
0x10000107	<p>File access error</p> <ul style="list-style-type: none"> <li>The file downloaded has an error.</li> <li>The header of the file which has been read has an error.</li> <li>The size of the file to be downloaded is too large.</li> <li>When it is identified to be the different type of F/W.</li> </ul>	<ul style="list-style-type: none"> <li>Check to see if the downloaded F/W is of the correct type.</li> </ul>
0x10000108	<ul style="list-style-type: none"> <li>The area F/W is stored is destroyed, and another ISW is necessary.</li> </ul>	<ul style="list-style-type: none"> <li>Wait until ISW is automatically executed on MFP side.</li> </ul>
0x20000000	<p>The temporary error when running the subset</p> <ul style="list-style-type: none"> <li>When starting the Internet ISW in a normal program, the rebooting will start and the Internet ISW will be executed with the subset program. During the process by the subset program, it has to be in the "Failed" status unless the Internet ISW is successfully conducted. This code is used temporarily to make it in error status.</li> </ul>	

# Troubleshooting

## 4. Checking the system configuration

- When a malfunction occurs, let the printer print a configuration page to check for system configuration.
  1. Press the Utility/Counter key.
  2. Touch [User Setting] → [Printer Setting] → [Print Reports].
  3. Touch [Configuration Page] and press the Start key.

## 5. Status codes

Code	Description	Action
CA051	Standard controller configuration failure	Change the MFP board (MFPB).
CA052	Faulty controller hardware	Change the MFP board (MFPB).
CA053	Controller start failure	Change the MFP board (MFPB) if the problem occurs again when turning OFF the main power switch and turn it ON again more than 10 seconds after.

See P.486 of the main body service manual.

## 6. Troubleshooting procedures

### 6.1 Unable to print over the network.

	Check		Possible Cause	Action	Remark
1	Is the print job displayed on the machine control panel?	Yes	An error on machine side (paper running out, toner running out, etc.)	Correct the error.	See "User's Guide [Copy Operations]" of the machine.
			Waiting its turn	Check the machine control panel for jobs in print queue. Priority may be changed as necessary.	
			The job is locked.	Enter the password to unlock the job.	See "User's Guide [Print Operations]."
			The correct division ID has not been entered.	Enter the correct division ID in the printer driver and try re-transmitting the job again. (access code)	
		No	Data is yet to be received.	Go to item 2.	

	Check		Possible Cause	Action	Remark
2	Is the response of Ping sent from the PC to the machine?	Yes	The print destination port setting is wrong.	Set the correct port.	See "User's Guide [Print Operations]."
			PC operates erratically temporarily.	Restart the PC.	
			Printer driver incorrectly installed	Uninstall the printer driver through the proper steps and then reinstall it properly.	See "User's Guide [Print Operations]."
		No	Controller board (MFP Control Board) operates erratically temporarily.	Restart the controller board.	Turn OFF the Main Power Switch and turn it ON again more than 10 seconds after.
			Network cable is disconnected or a relay device is faulty.	Reconnect the cable and restart or change the faulty relay device.	Check with the controller network LED.
			IP address and/or subnet mask incorrectly set.	Set the correct IP address and subnet mask.	See "TCP/IP Setting" in Installation Guide.

## 6.2 Unable to transmit data through Scan to FTP.

	Check	Possible Cause	Action	Remark
1	The message "Failed to connect to the destination" appears.	The FTP server is not in service.	Check with the network administrator.	See "User's Guide [Network Scanner Operations]."
IP address of the FTP server is wrong.		Check with the network administrator and enter the correct IP address.		
Proxy setting is wrong.		Check with the network administrator and make the correct proxy setting.		
Port number is wrong.		Check with the network administrator and enter the correct port number.		
A directory not existing in the FTP server is specified.		Check with the network administrator and enter the correct directory.		
Failed to log on to the FTP server because of the wrong user account.		Check with the network administrator and enter the correct user name and password.		
A timeout condition occurs.		Set a longer value for "FTP Connection Timeout." The timeout value depends on the network's traffic conditions and load on the FTP server.		
2	The message "Server Connect error" appears.	The network is disconnected during file transfer.	Send Ping from PC to the controller and FTP server to check to see if both parties are connected to the network or not.	
The FTP server hard disk becomes full during file transfer.		Check with the network administrator.		
The FTP server stops during file transfer.		Check with the network administrator.		



### 6.3 Unable to transmit data through Scan to E-Mail.

	Check	Possible Cause	Action	Remark
1	The message "Server Connect error" appears.	The SMTP server is not in service.	Check with the network administrator.	See "User's Guide [Network Scanner Operations]."
		IP address of the SMTP server is wrong.	Check with the network administrator and enter the correct IP address.	
		Port number is wrong.	Check with the network administrator and enter the correct port number.	
		A timeout condition occurs.	Set a longer value for "SMTP Connection Timeout." The timeout value depends on the network's traffic conditions and load on the FTP server.	
		The network is disconnected during file transfer.	Send Ping from PC to the controller and SMTP server to check to see if both parties are connected to the network or not.	
2	The message "E-mail Size Over" appears.	The size of the scan data exceeds the upper limit value set for maximum e-mail size.	Decrease resolution to make small the data size or change the setting for scanned file separation and binary division as necessary so that the scan data does not exceed the maximum e-mail size.	See "User's Guide [Network Scanner Operations]."

### 6.4 E-mail does not reach the destination when transmission through Scan to E-Mail is completed.

	Check	Possible Cause	Action	Remark
1	An error message is returned from the mail server.	Yes The destination mail address is wrong.	Enter the correct mail address.	See "User's Guide [Network Scanner Operations]."
		No The receiving end is being unable to receive, or is not receiving, mail stored in the POP3 server.		



KONICA MINOLTA

**SERVICE MANUAL**

**FIELD SERVICE**

---

# i-Option

# LK-101/102/103





# Revision history

After publication of this service manual, the parts and mechanism may be subject to change for improvement of their performance.

Therefore, the descriptions given in this service manual may not coincide with the actual machine.

When any change has been made to the descriptions in the service manual, a revised version will be issued with a revision mark added as required.

Revision mark:

- To indicate clearly a specific section revised within text,  is shown at the left margin of the corresponding revised section.  
The number inside  represents the number of times the revision has been made.
- To indicate clearly a specific page that contains a revision or revisions, the page number appearing at the left or right bottom of the specific page is marked with .  
The number inside  represents the number of times the revision has been made.

## NOTE

Revision marks shown in a page are restricted only to the latest ones with the old ones deleted.

- When a page revised in Ver. 2.0 has been changed in Ver. 3.0:  
The revision marks for Ver. 3.0 only are shown with those for Ver. 2.0 deleted.
- When a page revised in Ver. 2.0 has not been changed in Ver. 3.0:  
The revision marks for Ver. 2.0 are left as they are.

2008/01	1.0	—	Issue of the first edition
Date	Service manual Ver.	Revision mark	Descriptions of revision

# CONTENTS

## i-Option LK-101/102/103

### General

1.	Product outline .....	1
1.1	Available function for i-Option .....	1
1.2	Product specification.....	1
1.2.1	Web browser function .....	1
1.2.2	Photo registration function .....	2

### Adjustment/Setting

2.	How to use the adjustment section .....	3
3.	Service Mode .....	4
3.1	Billing Setting function setting procedure.....	4
3.2	Billing Setting function tree .....	5
3.3	Settings in the License management.....	6
3.3.1	Activation.....	6
3.3.2	Deactivation .....	6
3.3.3	Repair .....	6
3.3.4	Initialize .....	6
3.3.5	Request Code .....	6
3.3.6	List .....	7
3.4	License Management function setting procedure .....	8
3.4.1	Activation.....	8
3.4.2	Deactivation .....	12
3.4.3	Repair .....	17
3.4.4	Initialize .....	20

### Troubleshooting

4.	Troubleshooting of i-Option .....	21
4.1	Outline .....	21
4.1.1	Structure of license management .....	21
4.1.2	License management information.....	21
4.2	Error message .....	22
4.2.1	License management error .....	22

Blank Page

# General

## 1. Product outline

### 1.1 Available function for i-Option

- The functions available for i-Option LK-101/102/103 are as follows.

Function	Overview	Application		
		LK-101	LK-102	LK-103
Web browser	<ul style="list-style-type: none"> <li>From the control panel, access content on the Internet or Intranet, in order to display or print this content. Additionally, you can operate PageScope Web Connection to use documents saved in user boxes.</li> </ul>	✓		✓
Image panel	<ul style="list-style-type: none"> <li>This is a new control panel user interface. It enables the whole operation workflow to be easily grasped.</li> </ul>	✓		✓
Photo registration	<ul style="list-style-type: none"> <li>You can add photo data to a registered address book entry. Registered photos are reflected in the Destination List of the Image Panel.</li> </ul>	✓		✓
Assignment of application keys	<ul style="list-style-type: none"> <li>Enhanced function can be assigned to the application key.</li> </ul>	✓	✓	✓
PDF process	<ul style="list-style-type: none"> <li>When transmitting documents in PDF format, you can encrypt PDF file with password or digital ID, add a digital signature, and specify properties.</li> </ul>		✓	✓

#### NOTE

- If PageACES or a charging management device is installed on the MFP, then LK-101 or LK-103 cannot be registered.
- If authentication is performed with PageScope Authentication Manager, then the Web browser function cannot be used.

## 1.2 Product specification

### 1.2.1 Web browser function

- Main specifications of the web browser installed are as follows.

Browser engine	NetFront
Supported protocols	HTTP, HTTPS, TCP/IP
Supported markup/script languages	HTML, CSS, JavaScript
Supported image formats	JPEG, BMP, PNG, GIF, Animation GIF, PDF
Supported SSL/TLS versions	SSL2.0, SSL3.0, TLS1.0
Supported character codes	Western (ISO-8859-1), Unicode (UTF-8), Simplified Chinese (GB2312), Traditional Chinese (Big5), Japanese (Shift-JIS), Japanese (ISO-2022-JP), Japanese (EUC-JP)
Display modes	Normal, Just-Fit Rendering, Smart-Fit Rendering
Option	Adobe® Reader® LE

**1.2.2 Photo registration function**

- Specifications of the photo data to be registered are as follows.

File type	BMP format, 24-bit color, uncompressed
Image size	48 x 48 pixels
Data size	6,966 Byte

# Adjustment/Setting

## 2. How to use the adjustment section

- “Adjustment/Setting” contains detailed information on the adjustment items and procedures for this machine.
- Throughout this “Adjustment/Setting,” the default settings are indicated by “ ”.

### Advance checks

Before attempting to solve the customer problem, the following advance checks must be made. Check to see if:

- The power supply voltage meets the specifications.
- The power supply is properly grounded.
- The machine shares the power supply with any other machine that draws large current intermittently (e.g., elevator and air conditioner that generate electric noise).
- The installation site is environmentally appropriate: high temperature, high humidity, direct sunlight, ventilation, etc.; levelness of the installation site.
- The original has a problem that may cause a defective image.
- The density is properly selected.
- The original glass, slit glass, or related part is dirty.
- Correct paper is being used for printing.
- The units, parts, and supplies used for printing (developer, PC drum, etc.) are properly replenished and replaced when they reach the end of their useful service life.
- Toner is not running out.

### CAUTION

- **To unplug the power cord of the machine before starting the service job procedures.**
- **If it is unavoidably necessary to service the machine with its power turned ON, use utmost care not to be caught in the scanner cables or gears of the exposure unit.**
- **Special care should be used when handling the fusing unit which can be extremely hot.**
- **The developing unit has a strong magnetic field. Keep watches and measuring instruments away from it.**
- **Take care not to damage the PC drum with a tool or similar device.**
- **Do not touch IC pins with bare hands.**



## 3. Service Mode

- When using i-Option LK-101/102/103, license management is done with the following procedures. [Service Mode] → [Billing Setting] → [License Management]
- [License Management] can set Activation/Deactivation of each i-Option functions, Repair/Initialize of functions for troubleshooting, or etc.

### 3.1 Billing Setting function setting procedure

1. Press the Utility/Counter key.
2. Touch [Check Details] on meter count display.
3. Press the following keys in this order.; Stop → 0 → 0 → Stop → 0 → 1

#### NOTE

- When selecting [CE Authentication] under [Enhanced Security] available from Service Mode, authentication by CE password is necessary.  
Enter the 8 digits CE password, and touch [END].  
(The initial setting for CE password is “92729272.”)
- When the following setting is set to “ON”, CE password authentication is necessary.

[Administrator Settings] → [Security Settings] → [Enhanced Security Mode]

- If a wrong CE password is entered, re-enter the right password. The machine will not enter Service Mode unless the CE password is entered correctly. To return to the Basic screen, turn OFF the sub power switch and turn it ON again.  
When the following setting is set to “Mode 2”, operation will be prohibited since it indicates authentication failure by failing to enter the correct CE password within the specified number of times.

if the access lock is activated, the lock release timer starts to operate by input the Stop → 0 → 9 → 3 → 1 → 7 in [Meter Count] → [Check Details] → [Coverage Rate] after the main power switch is turned OFF and On. When the timer reaches the time specified in this setting, the access lock is released.

- The service code entered is displayed as “\*.”

4. The Service Mode menu will appear.

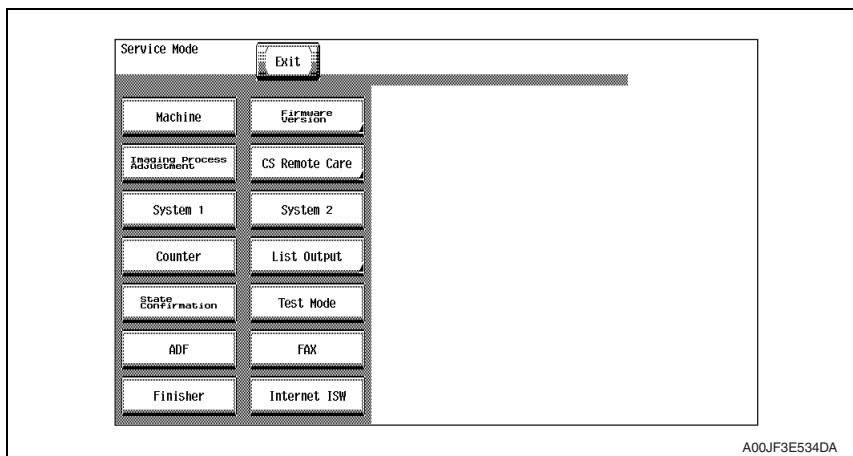

A00JF3E534DA

5. Press the following keys in this order.  
Stop → 9
6. Billing Setting menu will appear.

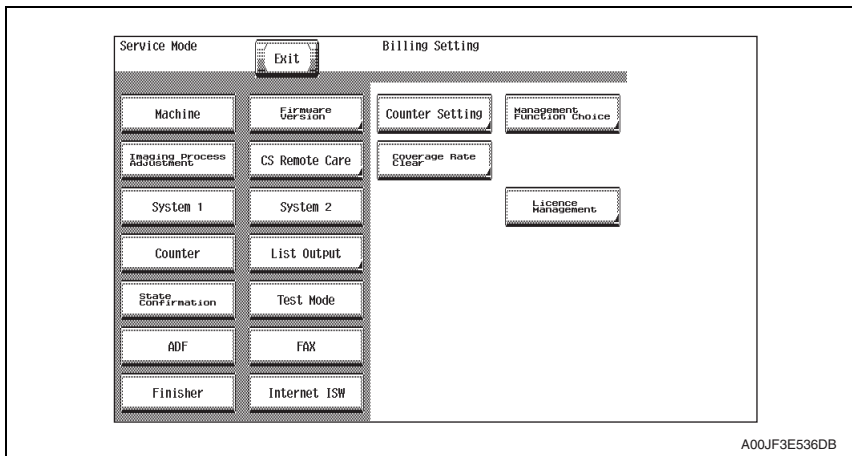

### 3.2 Billing Setting function tree

Service Mode		Ref. Page	
Billing Setting	Counter Setting	*1	
	Management Function Choice		
	Coverage Rate Clear		
	License Management *2	Activation *2	P.6
		Deactivation *2	P.6
		Repair *2, 3	P.6
		Initialize *2	P.6
		Request Code *2	P.6
	List *2	P.7	

\*1: For details, see the main body service manual.

\*2: It is displayed only when the expanded memory furnished with the optional upgrade kit UK-201 is mounted.

\*3: It is displayed only when "license management error" occurs.

See P.22

### 3.3 Settings in the License management

#### 3.3.1 Activation

Functions	<ul style="list-style-type: none"> <li>To activate i-Option functions.</li> </ul>
Use	<ul style="list-style-type: none"> <li>To activate i-Option functions with CE.</li> <li>The functions can be activated by selecting the desired function and enter the appropriate license code.</li> <li>Administrators also can activate i-Option functions through Administrator Settings.</li> </ul>
Setting/ Procedure	See P.8

#### 3.3.2 Deactivation

Functions	<ul style="list-style-type: none"> <li>To deactivate i-Option functions.</li> </ul>
Use	<ul style="list-style-type: none"> <li>To deactivate i-Option functions due to registration error, expiration of lease term, change to other MFP or etc.</li> <li>The functions can be deactivated by selecting the desired function and enter the appropriate deactivation code.</li> </ul>
Setting/ Procedure	See P.12

#### 3.3.3 Repair

Functions	<ul style="list-style-type: none"> <li>To repair license management information.</li> </ul>
Use	<ul style="list-style-type: none"> <li>To be used when license management information is lost due to replacement of NVRAM board or service EEPROM board or any other trouble.</li> <li>License management information can be repaired by acquiring repair code with repair request code, and entering the repair code.</li> </ul>
Setting/ Procedure	See P.17

#### 3.3.4 Initialize

Functions	<ul style="list-style-type: none"> <li>To initialize license management information.</li> </ul>
Use	<ul style="list-style-type: none"> <li>To be used when license management information cannot be repaired.</li> <li>License management information should be initialized when the machine fails to generate request code or repair request code due to any trouble and the information cannot be repaired.</li> </ul>
Setting/ Procedure	See P.20

#### 3.3.5 Request Code

- When the license management error is occurred, it will not be displayed until the repair code is input.

Functions	<ul style="list-style-type: none"> <li>To display and print request code and serial number.</li> </ul>
Use	<ul style="list-style-type: none"> <li>To check the request code and serial number.</li> </ul>
Setting/ Procedure	<ul style="list-style-type: none"> <li>Set A4S or 8 1/2 x 11S paper to the tray, and press start key at request code screen to print.</li> </ul>

**3.3.6 List**

Functions	<ul style="list-style-type: none"><li>• To display activated functions.</li><li>• To display and print deactivation complete code and serial number.</li></ul>
Use	<ul style="list-style-type: none"><li>• To display activated functions.</li><li>• To display and print deactivation complete code and serial number.</li></ul>
Setting/ Procedure	<ul style="list-style-type: none"><li>• Set A4S or 8 1/2 x 11S paper to the tray, and press start key at deactivation complete code screen to print.</li></ul>

### 3.4 License Management function setting procedure

- Each setting procedure of License Management function is as follows.
- You need to access License Management System (LMS) to implement each function setting.

#### 3.4.1 Activation

1. Prepare "token certification."
2. Call the Billing Setting to the screen.  
[See P.4](#)
3. Display and confirm the serial number and request code with the following procedure.  
[License Management] → [Request code]  
[See P.6](#)

#### NOTE

- **The function enhanced version firmware for i-Option is set at the factory before shipping, this procedure is not needed.**
4. Access to LMS web site (for service).
  5. Click [License Registration].
  6. Select the language.

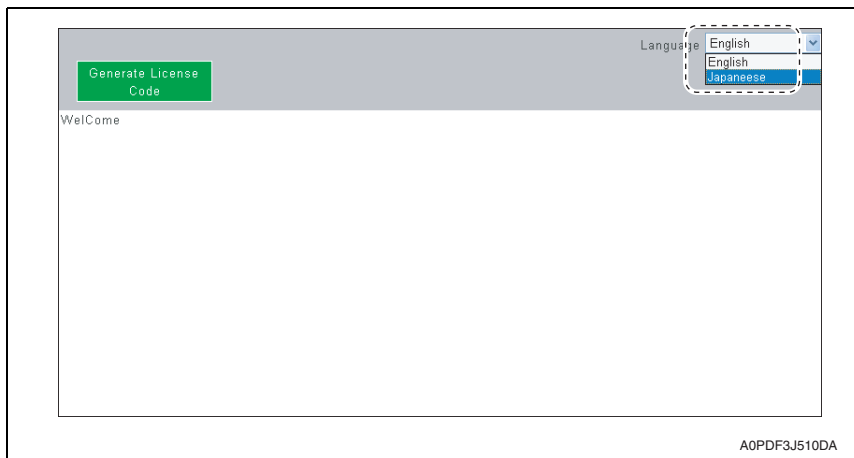

7. Enter request code and serial number, and click [Next].

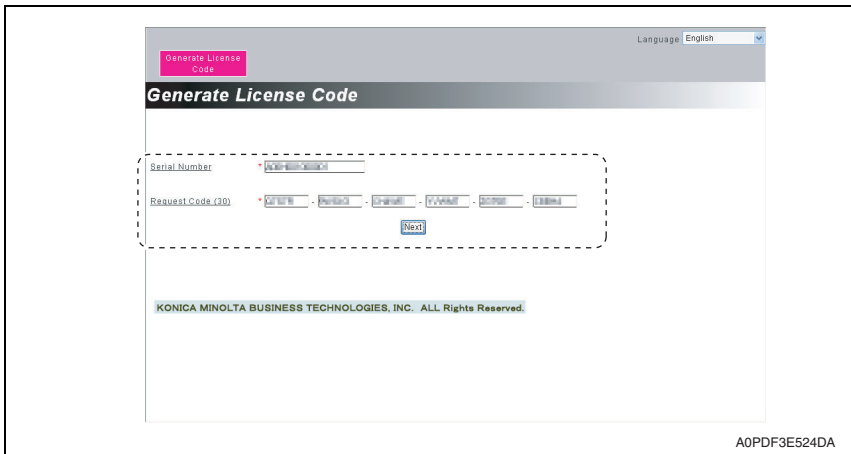

8. Enter “token number” described in the “token certificate”, and select the product name.  
9. Click [Next].

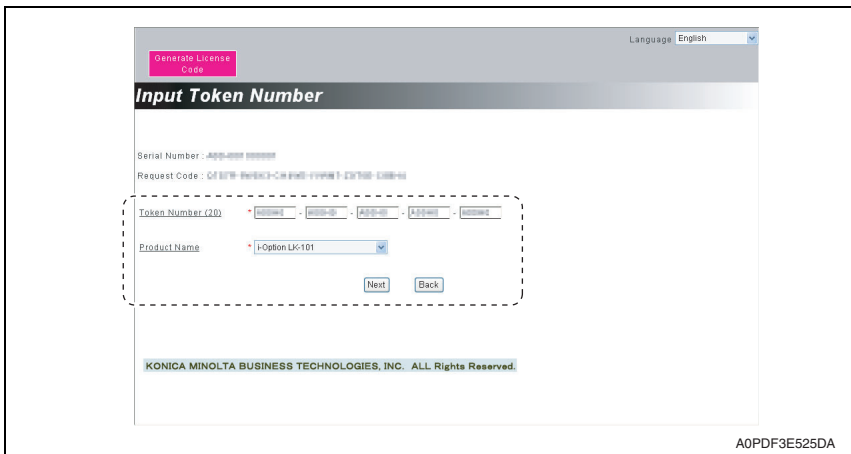

10. Confirm the registered information, and click [Generate License Code].

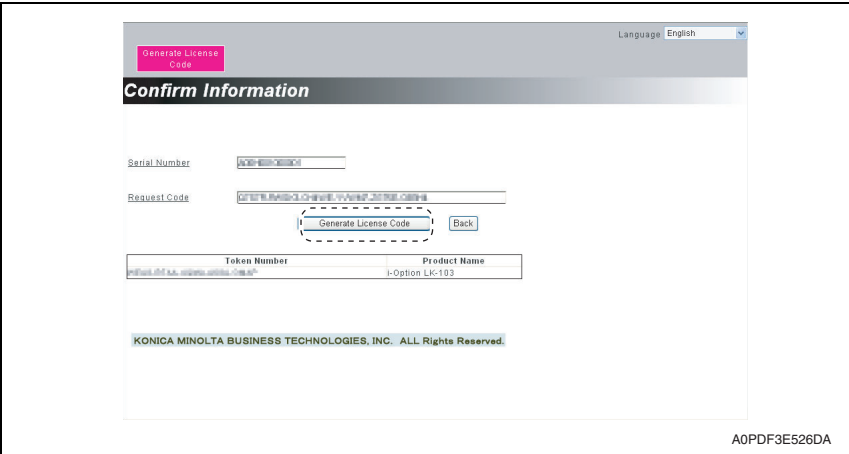

11. LMS issues license code.

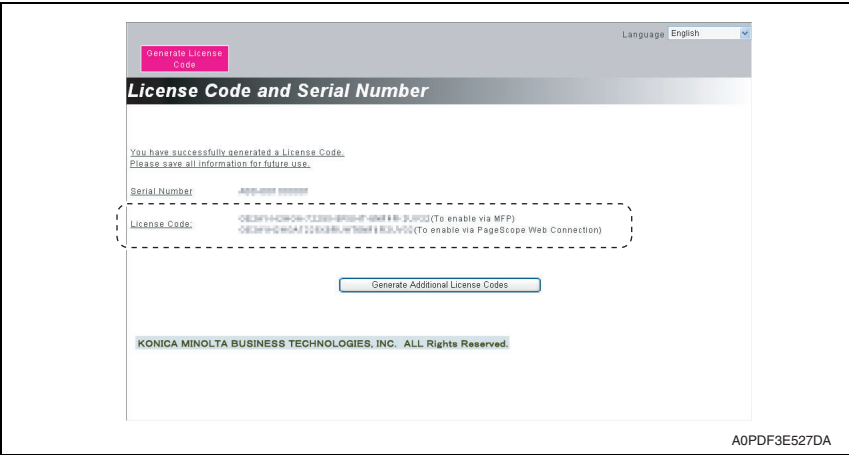

- 12. Select [Activation] → [License code] at the MFP.
- 13. Enter the license code issued by LMS using the keyboard on the screen, and touch [END].

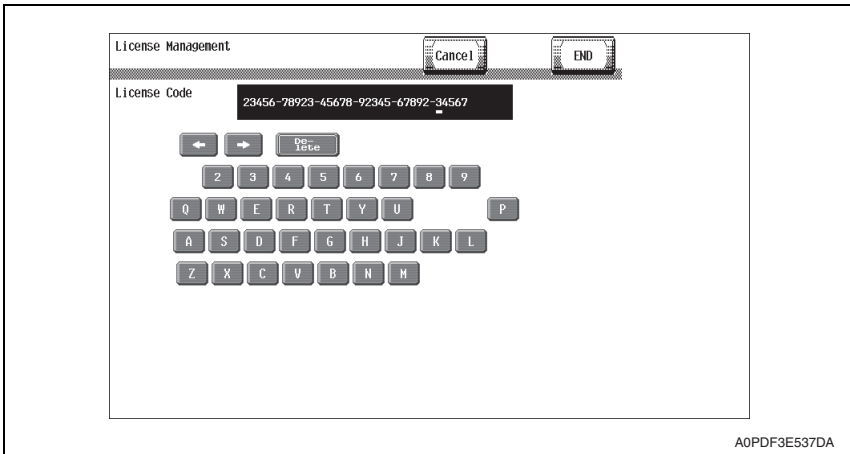

- 14. Select i-Option to be activated, and touch [Apply].

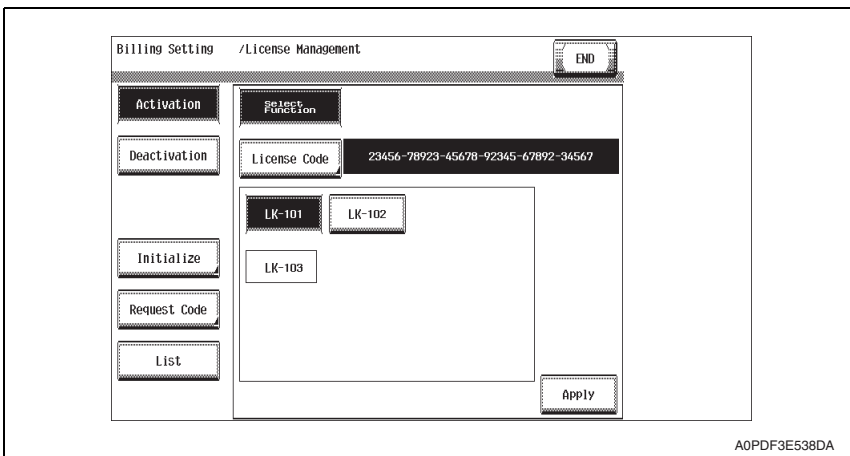

- 15. Follow the message appearing on the screen and turn OFF and ON the main power switch.



### 3.4.2 Deactivation

1. Call the Billing Setting to the screen.  
[See P.4](#)
2. Display and confirm the serial number with the following procedure.  
[License Management] → [Request code]  
[See P.6](#)
3. Access to LMS web site (for service).
4. Click [MFP] and select the language.

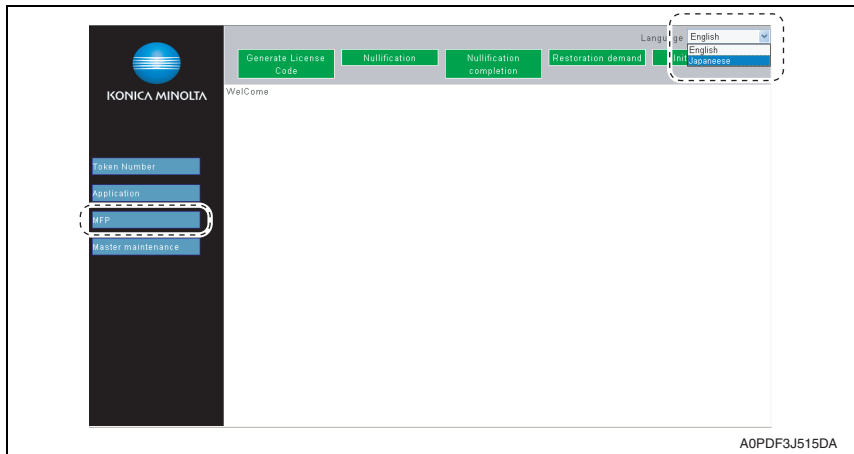

5. Click [Nullification].

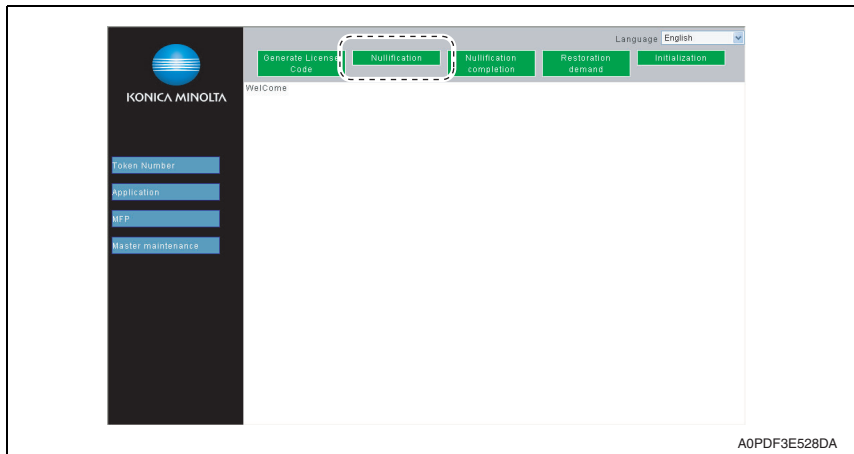

6. Enter serial number, and click [Retrieval].

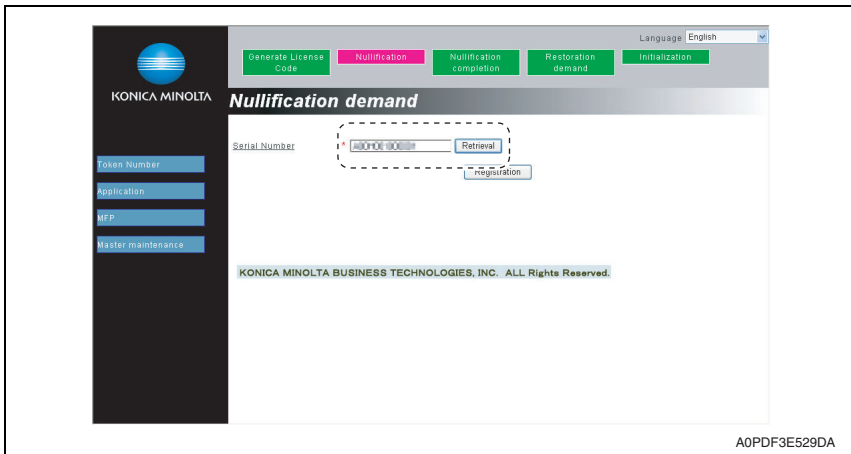

7. Select i-Option to be deactivated, and click [Registration].

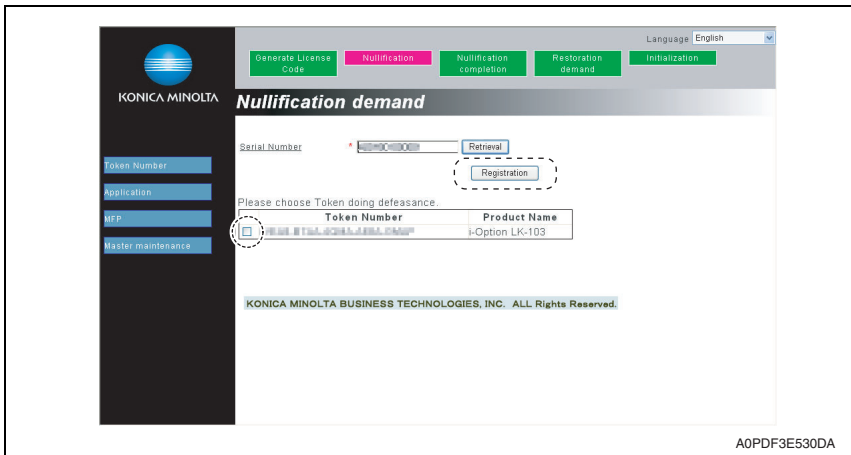

8. Nullification code is issued.

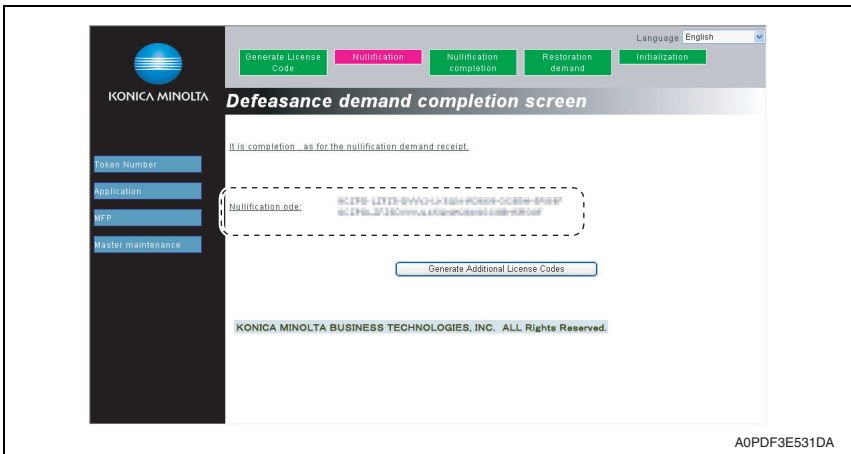

9. Select [Deactivation] → [Deactivation code] at the MFP.

10. Enter the nullification code issued by LMS using the keyboard on the screen, and touch [END].

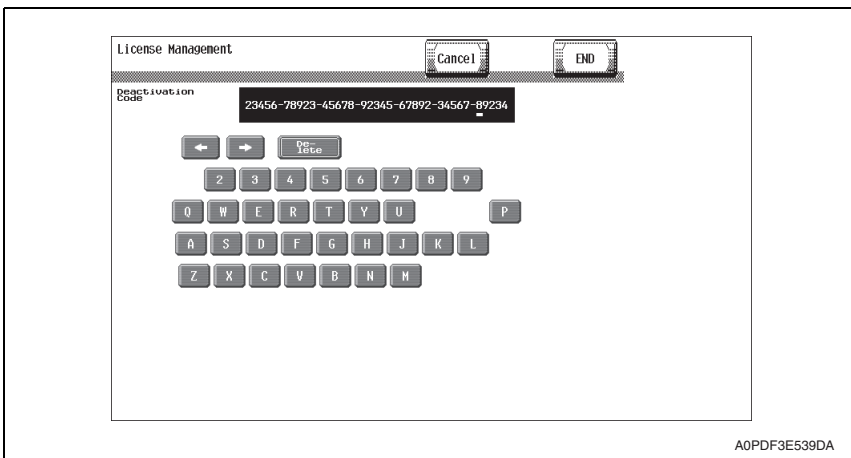

11. Select i-Option to be deactivated, and touch [Apply].

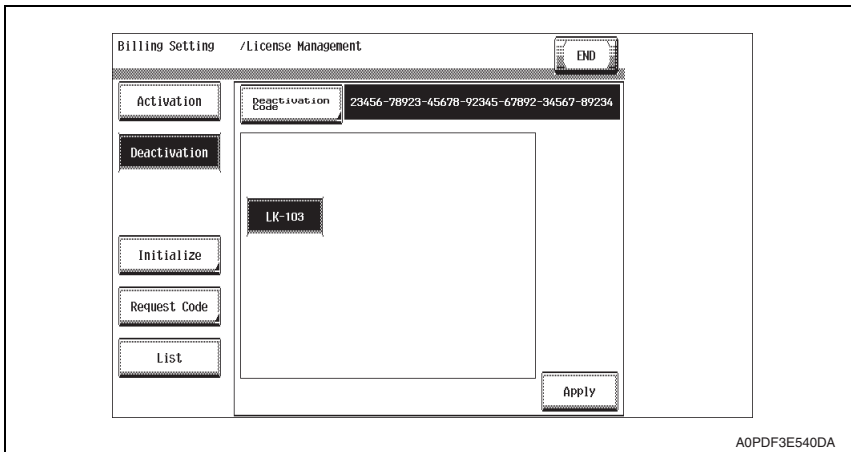

12. When the deactivation is done appropriately, serial number and deactivation complete code are issued.

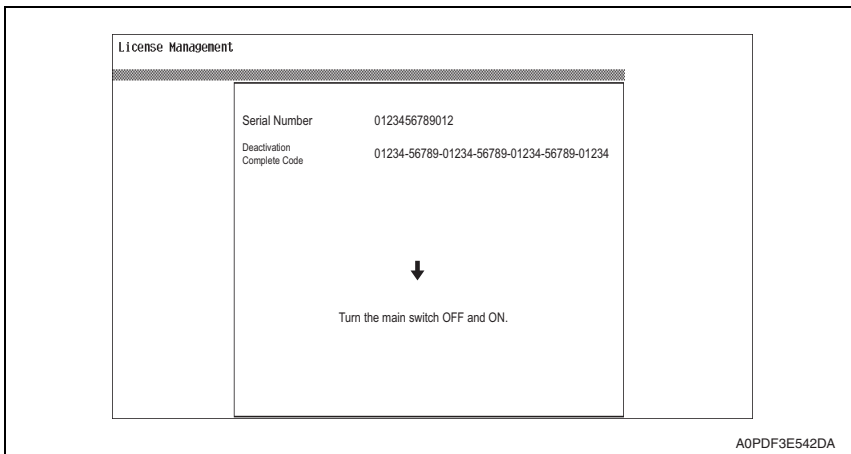

**NOTE**

- When A4S or 8 1/2 x 11S is set to the paper feed tray, the above-mentioned serial number and deactivation complete code can be printed out by pressing the start key.
- Serial number and deactivation complete code can be confirmed in [List] available from [License Management].

13. Follow the message appearing on the screen and turn OFF and ON the main power switch.

14. Click [Nullification completion] at LMS web site (for service).

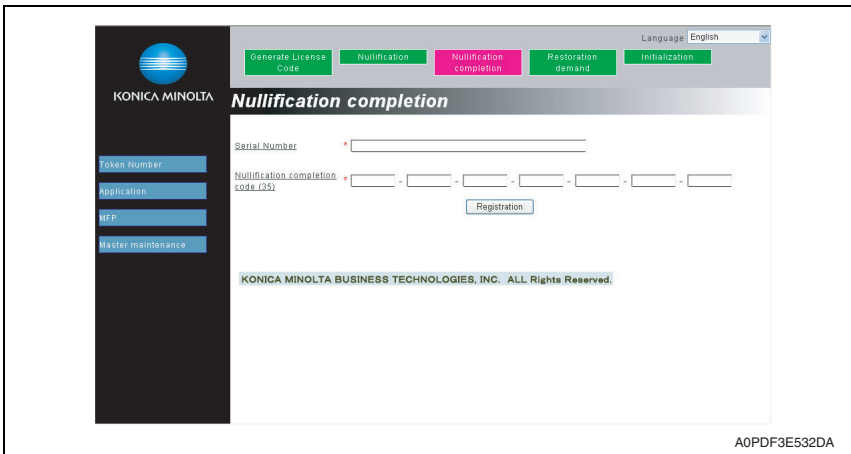

15. Enter serial number and nullification code, and click [Registration].

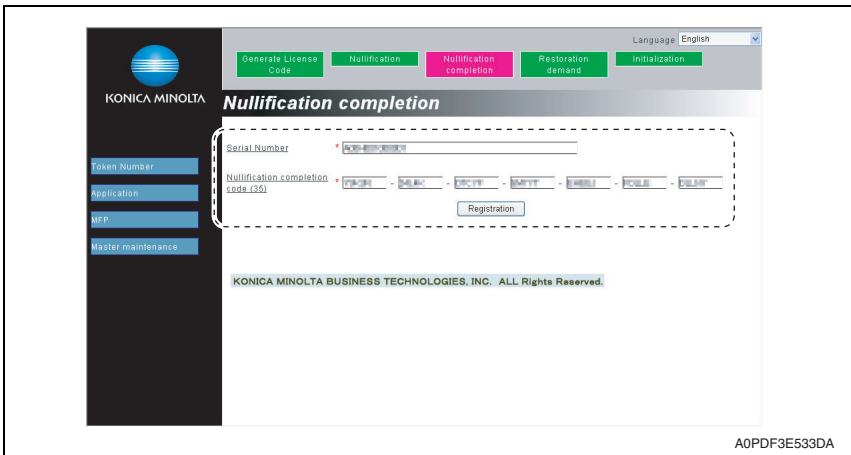

16. Message for nullification completion appears.

### 3.4.3 Repair

1. Call the Billing Setting to the screen.  
[See P.4](#)
2. Display and confirm serial number, repair request code and request code with the following procedure.  
[License Management] → [Repair] → [Repair Request Code]  
[See P.6](#)

#### NOTE

- Do not turn OFF/ON the main power switch until the repair code is input after this procedure.

3. Access to LMS web site (for service).
4. Click [MFP] and select the language.

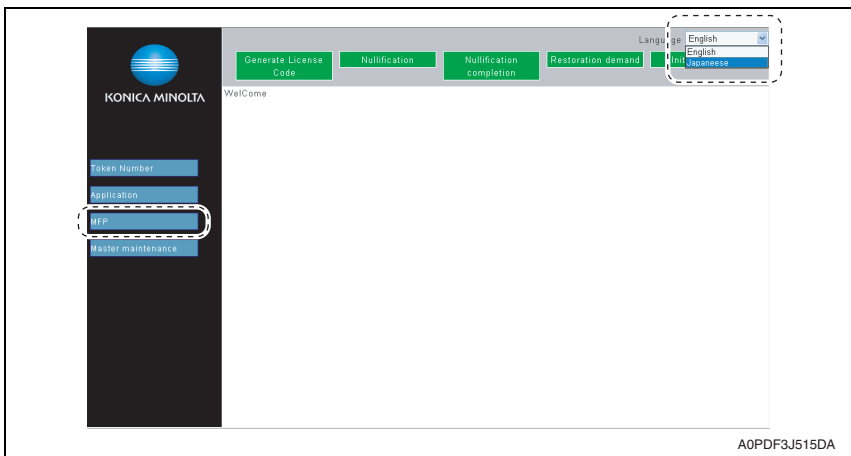

Adjustment / Setting

5. Click [Restoration demand].

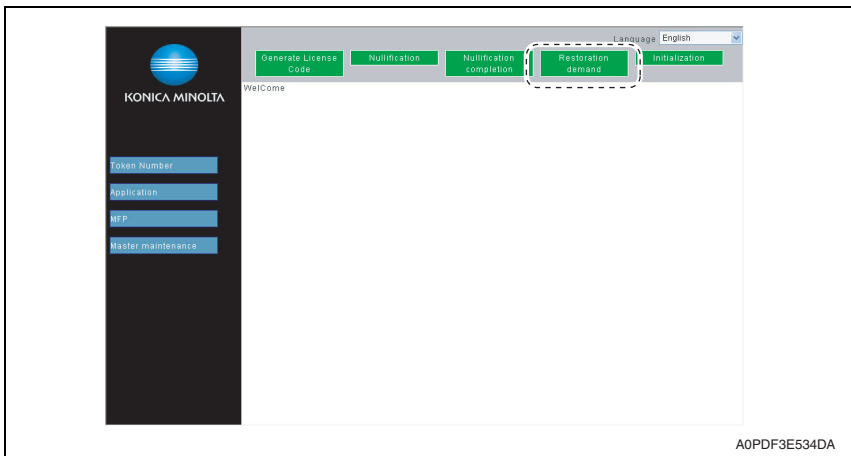

- 6. Enter serial number, restoration demand code and request code, and click [Registration].

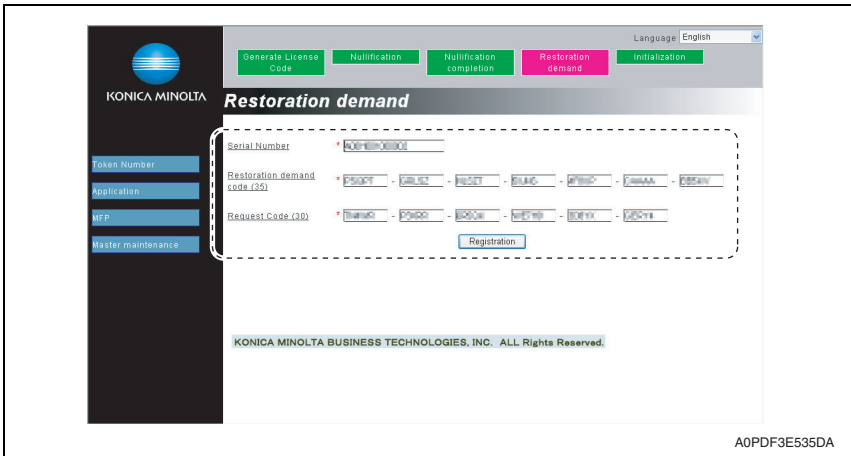

- 7. Request permission code is issued.  
If any function needs to be activated, appropriate license code is also issued.

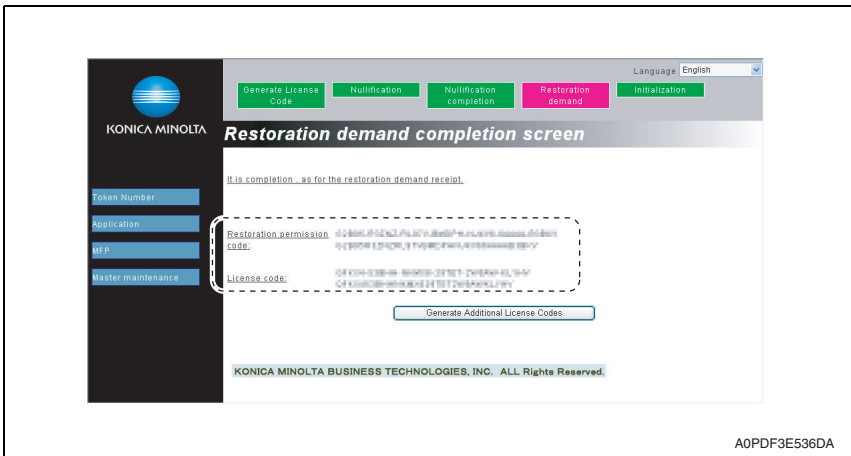

i-Option LK-101/102/103

Adjustment / Setting

- 8. Select [Repair] → [Repair Code] at the MFP.
- 9. Enter the request permission code issued by LMS using the keyboard on the screen, and touch [END].

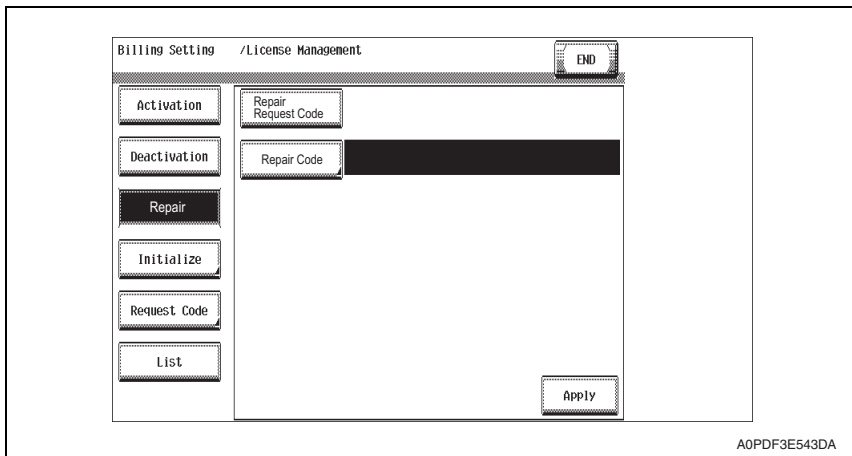

- 10. Touch [Apply].

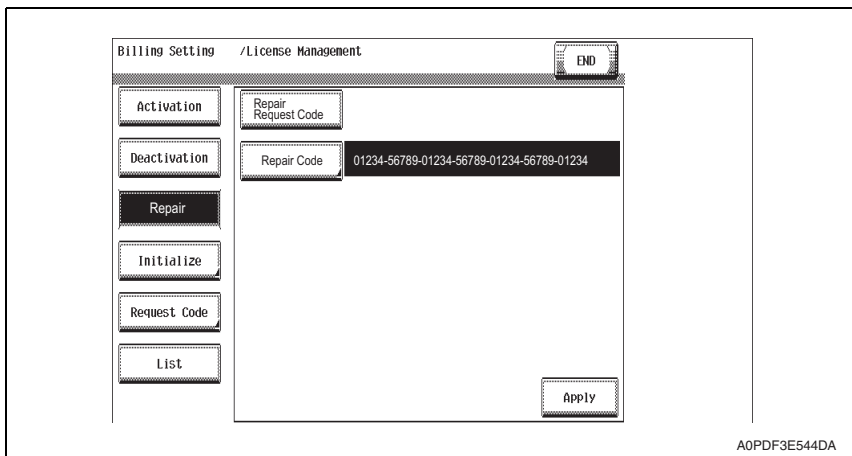

- 11. Close Service Mode, confirm that the functions work correctly.



### 3.4.4 Initialize

- When license management information cannot be repaired, initialize the information with the following procedure.
  1. Contact the license management section of sales company to report the information necessary to issue the initialize code.
  2. The license management section of sales company supplies the initialize code.
  3. Call the Billing Setting to the screen.  
[See P.4](#)
  4. Touch [License Management] → [Initialize].
  5. Enter the initialize code issued by call center using the keyboard on the screen, and touch [Apply].

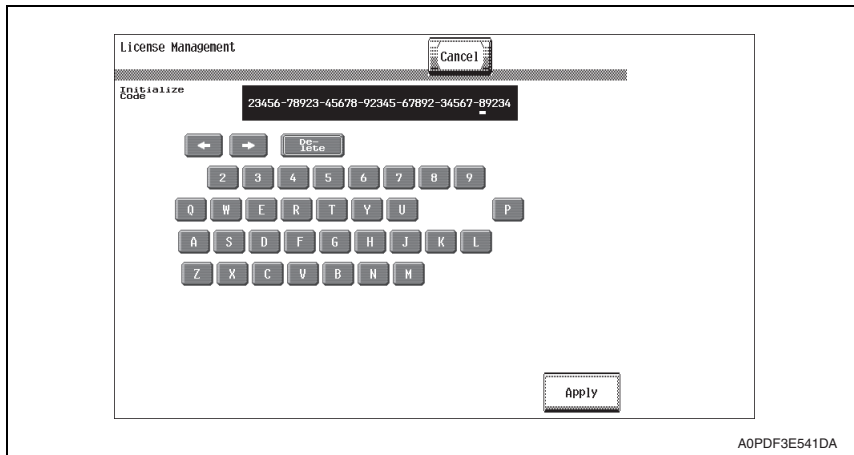

6. After completing the initialization, follow the message appearing on the screen and turn OFF and ON the main power switch.

# Troubleshooting

## 4. Troubleshooting of i-Option

### 4.1 Outline

#### 4.1.1 Structure of license management

- The functions available with i-Option can be activated by entering “License code” to the MFP.
- License code is issued and controlled by License Management System (LMS).  
To prevent unauthorized use of the license code, each MFP is identified individually so that the license code cannot be activated unless it matches with the authorized MFP.

#### 4.1.2 License management information

- Since license code needs to identify each MPF, it is issued using the serial number of MFP and “unique value” that is generated inside MFP.
- The “unique value” is stored to the NVRAM board on the MFP board and at the same time some parts of it are memorized by service EEPROM board. The activated function cannot be used unless the both figures conform.  
Since these figures are out of target of NVRAM data back, when any trouble occurs at either nonvolatile memory or either of them is replaced with new one, “license management error” is generated due to discordance of the figures.

## 4.2 Error message

### 4.2.1 License management error

- When abnormal value is detected in the license management information that is stored to the NVRAM board or service EEPROM board, or some values are detected cleared, warning is issued to let the user know the abnormality.
- The abnormality is detected at the timing of start-up or restart due to any condition.
- When the abnormality is detected, the corresponding i-Option function cannot be used, other ordinal functions, however, such as copy, scanning, print or etc, can be used without interruption.

#### A. Example of error message

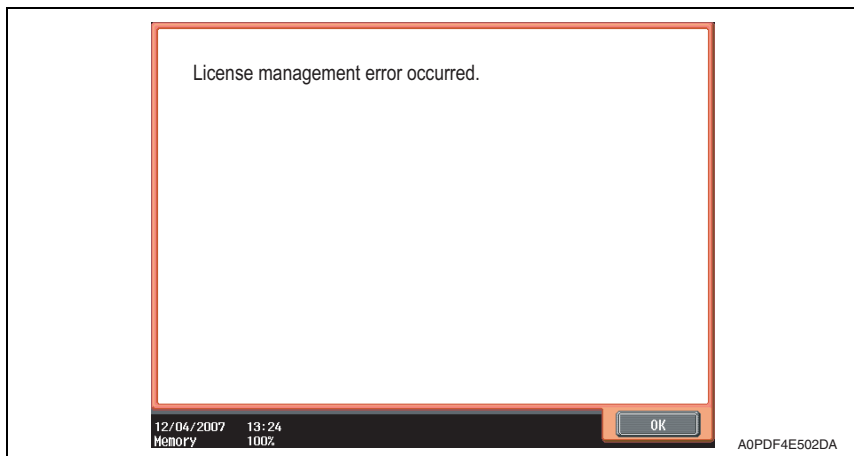

#### B. Main reasons of trouble

- The following shows the possible trouble factors and their countermeasure.

Board replacement	Countermeasure
• When NVRAM board on MFP board is replaced with new one.	Repair ⇒ Activation
• When service EEPROM board is replaced with new one.	Repair
• When NVRAM board and service EEPROM board are replaced with the new ones at the same time.	Initialize ⇒ Activation
• When mounting the NVRAM board of the machine whose function(s) have already been activated.	Initialize ⇒ Activation
• When mounting the service EEPROM board of the machine whose function(s) have already been activated.	Initialize ⇒ Activation
• When mounting the NVRAM board and the service EEPROM board of the machine whose function(s) have already been activated.	Initialize ⇒ Activation



KONICA MINOLTA

# SERVICE MANUAL

FIELD SERVICE

---

# DF-611





# Revision history

After publication of this service manual, the parts and mechanism may be subject to change for improvement of their performance.

Therefore, the descriptions given in this service manual may not coincide with the actual machine.

When any change has been made to the descriptions in the service manual, a revised version will be issued with a revision mark added as required.

Revision mark:

- To indicate clearly a specific section revised within text,  is shown at the left margin of the corresponding revised section.  
The number inside  represents the number of times the revision has been made.
- To indicate clearly a specific page that contains a revision or revisions, the page number appearing at the left or right bottom of the specific page is marked with .  
The number inside  represents the number of times the revision has been made.

## NOTE

Revision marks shown in a page are restricted only to the latest ones with the old ones deleted.

- When a page revised in Ver. 2.0 has been changed in Ver. 3.0:  
The revision marks for Ver. 3.0 only are shown with those for Ver. 2.0 deleted.
- When a page revised in Ver. 2.0 has not been changed in Ver. 3.0:  
The revision marks for Ver. 2.0 are left as they are.

2008/01	2.0		Content additions/Error correction
2007/07	1.0	—	Issue of the first edition
Date	Service manual Ver.	Revision mark	Descriptions of revision

# CONTENTS

## DF-611

### General

1. Product specifications ..... 1

### Maintenance

2. Periodical check ..... 5

2.1 Maintenance procedure (Periodical check parts) ..... 5

2.1.1 Pick-up roller/feed roller ..... 5

2.1.2 Separation roller..... 7

2.1.3 Cleaning of the miscellaneous rolls ..... 9

2.1.4 Cleaning of the miscellaneous rollers ..... 11

2.1.5 Cleaning of the scanning guide..... 13

2.1.6 Cleaning of the reflective sensor section ..... 13

3. Service tool ..... 14

3.1 CE tool list..... 14

4. Other ..... 15

4.1 Disassembly/Adjustment prohibited items ..... 15

4.2 Disassembly/Assembly/Cleaning list (Other parts) ..... 16

4.2.1 Disassembly/Assembly parts list..... 16

4.3 Disassembly/Assembly procedure ..... 16

4.3.1 Feed cover ..... 16

4.3.2 Front cover ..... 17

4.3.3 Rear cover..... 18

4.3.4 Document feed tray front cover ..... 19

4.3.5 Reverse automatic document feeder ..... 19

4.3.6 DF control board ..... 21

4.3.7 Document width detection variable resistor ..... 21

4.3.8 Replacing the stamp unit ..... 24

4.3.9 Replacing the stamp ..... 25

### Adjustment/Setting

5. How to use the adjustment section ..... 27

6. Service Mode ..... 28

6.1 Service Mode setting procedure ..... 28

6.2 ADF setting procedure ..... 28

DF-611

General

Maintenance

Adjustment / Setting

Troubleshooting

6.2.1	Original Stop Position .....	28
6.2.2	Registration Loop Adj. ....	28
6.2.3	Auto Stop Position Adjustment .....	28
6.2.4	Paper Passage .....	29
6.2.5	Sensor Check .....	30
6.2.6	Original Tray Width.....	32
6.2.7	Read Pos Adj.....	32
6.2.8	Feed Zoom .....	32
6.2.9	Scanning Light Adjustment.....	32
7.	Mechanical adjustment .....	33
7.1	Adjusting the height.....	33
7.2	Adjusting skew feed.....	34
7.3	Original Stop Position.....	36
7.4	Original Tray Width .....	44
7.5	Read Pos Adj.....	46
7.6	Feed Zoom .....	49

## Troubleshooting

8.	Jam display .....	53
8.1	Initial check items .....	53
8.2	Misfeed display.....	53
8.2.1	Misfeed display resetting procedure .....	54
8.3	Sensor layout.....	54
8.4	Solution .....	55
8.4.1	Turnover section misfeed .....	55
8.4.2	Paper feed section misfeed.....	55
8.4.3	Transport section misfeed.....	56
8.4.4	Paper exit section misfeed .....	57
8.4.5	Image reading section misfeed .....	58
8.4.6	Original feeding interval misfeed.....	59
8.4.7	Remaining paper misfeed.....	59
9.	Trouble code .....	60
9.1	Trouble code list.....	60
9.2	Solution .....	61
9.2.1	C8101: Pressure/retraction mechanism failure before image reading.....	61
9.2.2	C8102: Pressure/retraction mechanism failure at the turnover section .....	61
9.2.3	C8103: Lift up mechanism failure .....	62
9.2.4	C8104: Original glass travel failure .....	62

9.2.5	C8302: Cooling fan failure.....	63
9.2.6	CC156: ADF ROM malfunction.....	63
9.2.7	Incorrect ROM content.....	63
10.	Set error detection.....	64

DF-611

General

Maintenance

Adjustment / Setting

Troubleshooting



DF-611

General

Maintenance

Adjustment / Setting

Troubleshooting

Blank Page

# General

## 1. Product specifications

### A. Type

Name	Reverse automatic document feeder	
Type	Paper feed section	Paper feed from top of stack
	Image reading section	Sheet-through system
	Turnover section	Switchback system
	Exit section	Straight exit system
Installation	Screw clamp to the main body	
Document alignment	Center	
Document loading	Face up	

### B. Functions

Modes	Standard mode / Mixed original detection mode / FAX mode
-------	--

### C. Paper type

Type of document	Standard mode Plain paper	1-sided mode 35 to 210 g/m <sup>2</sup> (9.25 to 55.75 lb)
		2-sided mode 50 to 128 g/m <sup>2</sup> (13.25 to 34 lb)
	Mixed original detection mode Plain paper	1-sided / 2-sided mode 50 to 128 g/m <sup>2</sup> (13.25 to 34 lb)
		FAX mode Plain paper
	2-Sided Mode 50 to 128 g/m <sup>2</sup> (13.25 to 34 lb)	
Detectable document size*1	Standard mode/FAX mode	Metric area: B6S to A3 Inch area: 5-1/2 x 8-1/2 to 11 x 17
Capacity	100 sheets (80 g/m <sup>2</sup> ) or stack of 14 mm and below	

\*1: For the combined original detection mode, refer to the mixed original detection enabled size combination table.

**D. Paper feed prohibited originals**

- If fed, trouble occurrence will be highly possible.

Type of original	Possible trouble
Sheets stapled or clipped together	Paper feed failure, damaged sheet, defective drive mechanism due to jammed staples or clips
Sheets glued together	Paper feed failure, damaged sheet
Book original	Paper feed failure, damaged sheet
Original weighing less than 35 g/m <sup>2</sup> (9.25 lb) or 210 g/m <sup>2</sup> (55.75 lb) or more	Paper feed failure, transport failure
Sheets folded, torn or wrinkled	Paper feed failure, damaged sheet, transport failure
Sheets severely curled	Sheets misfed due to being dog-eared or fed in askew
OHP film (Transparency film)	Paper feed failure, transport failure
Label paper	Paper feed failure, transport failure
Offset master paper	Paper feed failure, transport failure
Glossy photographic paper or glossy enamel paper	Transport failure, damaged sheet
Sheets clipped or notched	Damaged sheet, transport failure
Sheets patched	Patched part folded or torn sheet

**E. Paper feed not guaranteed originals**

- If fed, paper feed will be possible to some extent but trouble occurrence will be possible.

Type of Original	Possible Trouble
Sheets lightly curled (Curled amount: 10 to 15 mm)	Dog-eared, exit failure, transport failure
Heat sensitive paper	Edge folded, exit failure, transport failure
Ink jet paper	Paper feed failure, transport failure
Sheets with smooth surface (Coated paper)	Paper feed failure, transport failure
Intermediate paper	Paper feed failure, transport failure
Paper immediately after paper exit from the main unit	Paper feed failure, transport failure
Paper with many punched holes (e.g., loose leaf) limited to vertical feeding	Multi-page feed due to flashes from holes
Sheets with 2 to 4 holes	Transport failure
Sheets two-folded or Z-folded	Transport failure, image deformation
Sheets with rough surface (e.g., letterhead)	Paper feed failure

**F. Mixed original feed chart**

For metric

	Max. original size	297 mm		257 mm		210 mm		182 mm	148 mm	128 mm
		A3	A4	B4	B5	A4S	A5	B5S	A5S	B6S
297 mm	A3	OK	OK	—	—	—	—	—	—	—
	A4	OK	OK	—	—	—	—	—	—	—
257 mm	B4	OK	OK	OK	OK	—	—	—	—	—
	B5	OK	OK	OK	OK	—	—	—	—	—
210 mm	A4S	OK	OK	OK	OK	OK	OK	—	—	—
	A5	NG	NG	OK	OK	OK	OK	—	—	—
182 mm	B5S	NG	NG	OK	OK	OK	OK	OK	—	—
148 mm	A5S	NG	NG	NG	NG	NG	NG	NG	OK	—
128 mm	B6S	NG	NG	NG	NG	NG	NG	NG	OK	OK

For inch

	Max. original size	11		8-1/2			5-1/2
		11 x 17	8-1/2 x 11	8-1/2 x 14	8-1/2 x 11S	5-1/2 x 8-1/2	5-1/2 x 8-1/2S
11	11 x 17	OK	OK	—	—	—	—
	8-1/2 x 11	OK	OK	—	—	—	—
8-1/2	8-1/2 x 14	OK	OK	OK	OK	OK	—
	8-1/2 x 11S	OK	OK	OK	OK	OK	—
	5-1/2 x 8-1/2	NG	NG	OK	OK	OK	—
5-1/2	5-1/2 x 8-1/2S	NG	NG	NG	NG	NG	OK

OK	Mixed original feed available (Tilted with in 1.5% or less)
NG	No. mixed original feed
—	Can not set original

**G. Machine specifications**

Power requirements	DC 24 V (supplied from the main unit)
	DC 5 V (generated within the DF-611)
Max. power consumption	60 W or less
Dimensions	618 mm (W) x 575 mm (D) x 130 mm (H) 24.25 inch (W) x 22.75 inch (D) x 5 inch (H)
Weight	16.1 kg (35.5 lb)

**H. Operating environment**

Conforms to the operating environment of the main body.

**NOTE**

- **These specifications are subject to change without notice.**

# Maintenance

## 2. Periodical check

### 2.1 Maintenance procedure (Periodical check parts)

#### NOTE

- The alcohol described in the cleaning procedure of maintenance represents the isopropyl alcohol.

#### 2.1.1 Pick-up roller/feed roller

##### A. Periodically cleaning parts/cycle

- Pick-up roller: Every 50,000 prints
- Feed roller: Every 50,000 prints

##### B. Periodically replaced parts/cycle

- Pick-up roller: Every 200,000 prints
- Feed roller: Every 200,000 prints

##### C. Cleaning procedure

1. Open the feed cover.

See P.16

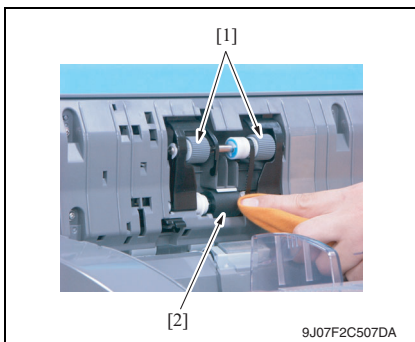

2. Wet a cloth with alcohol, and use it to wipe up the pick-up roller [1] and feed roller [2].

##### D. Replacing procedure

1. Open the feed cover.

See P.16

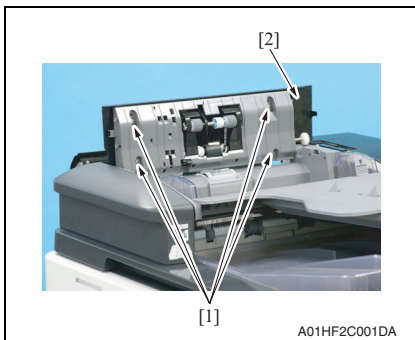

2. Remove four screws [1] and remove the cover [2].

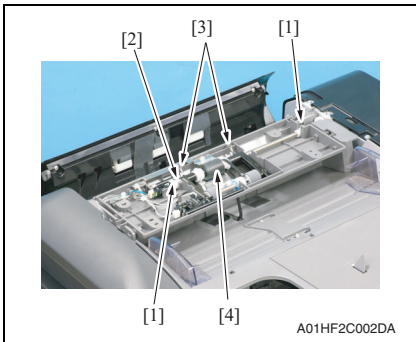

3. Remove two C-clips [1], the bearing [2] and two springs [3] and remove the pick-up/feed roller assy [4].

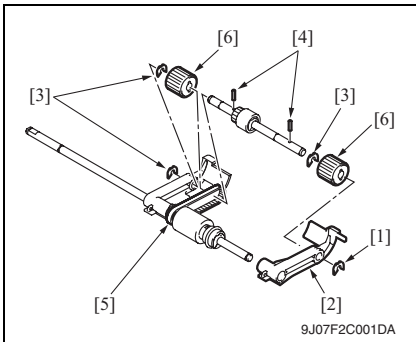

4. Remove the C-ring [1] and the lever [2].
5. Remove three C-rings [3].
6. Remove two pins [4].
7. Remove the belt [5].
8. Remove two pick-up rollers [6].

**NOTE**  
 • Be careful not to lose the pin.

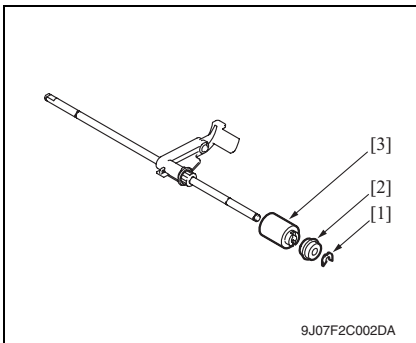

9. Remove the C-ring [1] and the bushing [2].
10. Remove the feed roller [3].

### 2.1.2 Separation roller

#### A. Periodically cleaning parts/cycle

- Separation roller: Every 50,000 prints

#### B. Periodically replaced parts/cycle

- Separation roller: Every 200,000 prints

#### C. Cleaning procedure

1. Open the feed cover.

See P.16

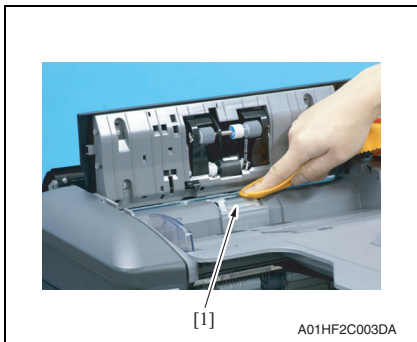

2. Wet a cloth with alcohol, and use it to wipe up the separation roller [1].

#### D. Replacing procedure

1. Open the transportation cover.
2. Lift up the document feed tray.

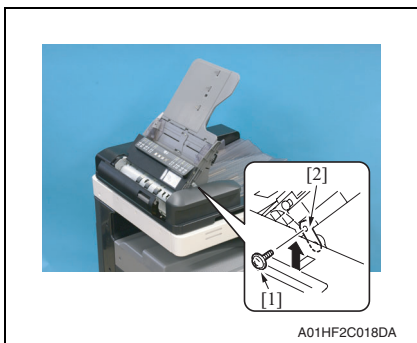

3. Remove the screw [1] and the mounting plate [2].

#### NOTE

- Be sure to hold the document feed tray to prevent the tray from falling down while removing the mounting plate.



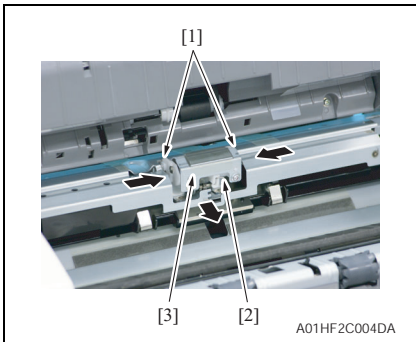

4. Hold the two sides [1] between your fingertips to unhook the spring [2] and remove the separation roller assy [3].

**NOTE**

- When reinstalling the separation roller assy, be sure to hook the spring onto the assy.

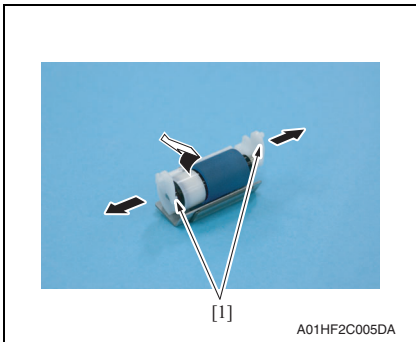

5. While opening up the holder [1], remove the shaft.

**NOTE**

- Opening the holder too much can break the holder.

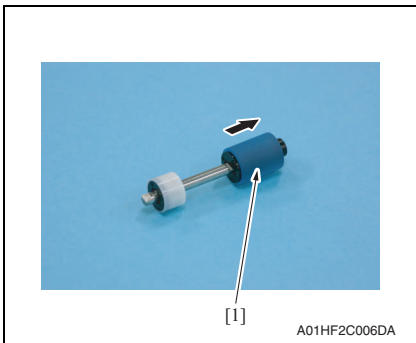

6. Remove the separation roller [1] from the shaft.

### 2.1.3 Cleaning of the miscellaneous rolls

#### A. Periodically cleaning parts/cycle

- Miscellaneous rolls: Every 50,000 prints

#### B. Cleaning procedure

1. Lift up the document feed tray.

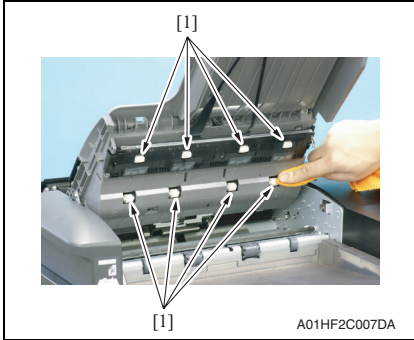

2. Using a soft cloth dampened with alcohol, wipe the roll [1].

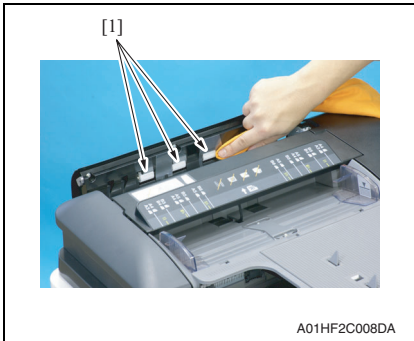

3. Open the transportation cover.
4. Using a soft cloth dampened with alcohol, wipe the roll [1].

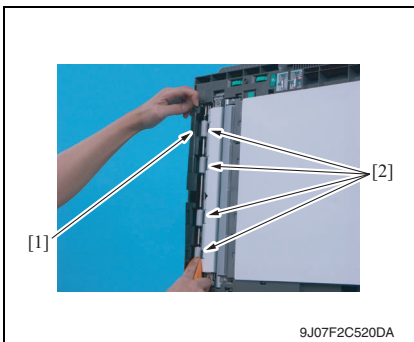

5. Open the reverse automatic document feeder.
6. While opening the before scanning mylar assy [1], wipe the roll [2] using a soft cloth dampened with alcohol.

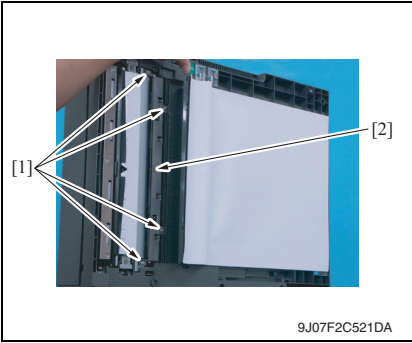

- 7. While opening the processing guide, remove four screws [1] and remove the transport roll assy [2].

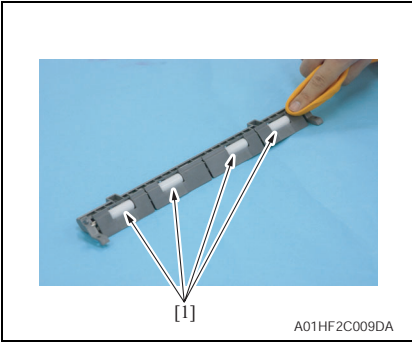

- 8. Using a soft cloth dampened with alcohol, wipe the roll [1].

### 2.1.4 Cleaning of the miscellaneous rollers

#### A. Periodically cleaning parts/cycle

- Miscellaneous rollers: Every 50,000 prints

#### B. Cleaning procedure

1. Open the transportation cover.



2. Using a soft cloth dampened with alcohol, wipe the roller [1].

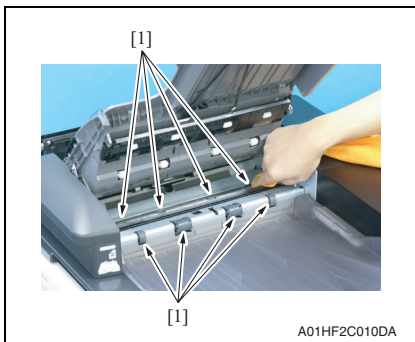

3. Lift up the document feed tray.
4. Using a soft cloth dampened with alcohol, wipe the roller [1].

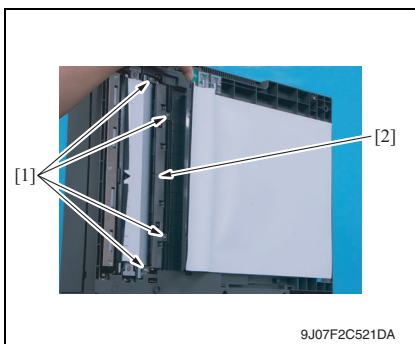

5. While opening the processing guide, remove four screws [1] and remove the transport roll assy [2].

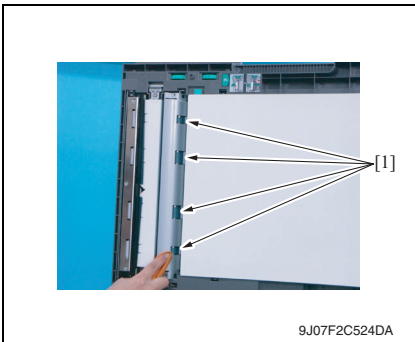

6. Using a soft cloth dampened with alcohol, wipe the roller [1].

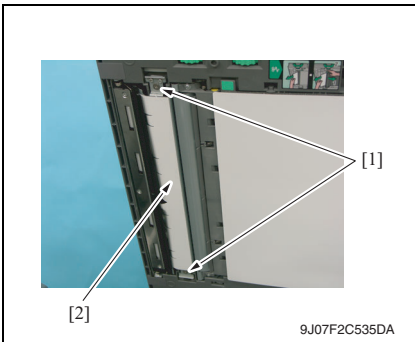

7. Remove two shoulder screws [1] and remove the scanning guide [2].

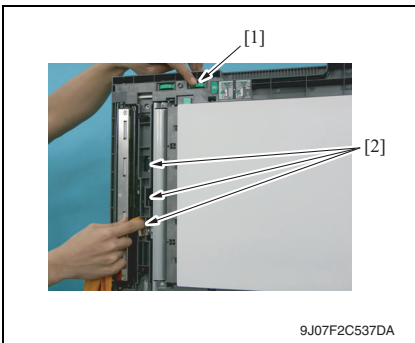

8. While turning processing knob [1], wipe the roller [2] using a soft cloth dampened with alcohol.

### 2.1.5 Cleaning of the scanning guide

#### A. Periodically cleaning parts/cycle

- Scanning guide: Every 50,000 prints

#### B. Cleaning procedure

1. Open the reverse automatic document feeder.

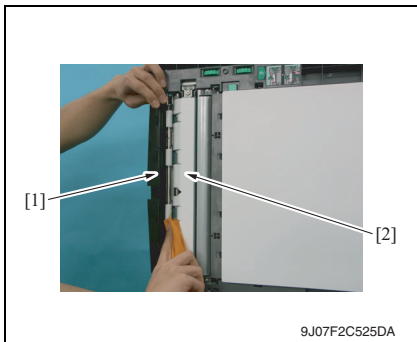

2. Open the before scanning mylar assy [1].
3. Using a soft cloth dampened with alcohol, wipe the scanning guide [2] clean of dirt.

#### NOTE

- Be careful not to damage the mylar.

### 2.1.6 Cleaning of the reflective sensor section

#### A. Periodically cleaning parts/cycle

- Reflective sensor section: Every 50,000 prints

#### B. Cleaning procedure

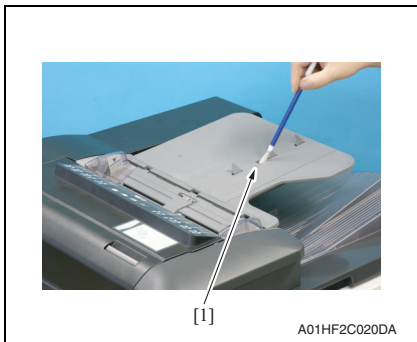

1. Clean the sensor [1] using a brush or other similar tools.

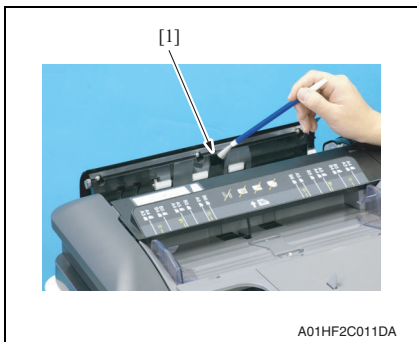

2. Open the transportation cover.
3. Clean the cloth [1] using a brush or other similar tools.

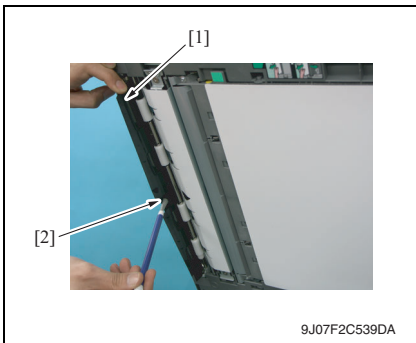

4. Open the reverse automatic document feeder.
5. While opening the before scanning mylar assy [1], clean the cloth [2] using a brush or other similar tools.

### 3. Service tool

#### 3.1 CE tool list

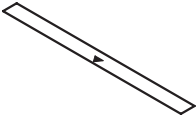
Tool name	Shape	Personnel	Parts No.	Remarks
ADF reading chart	 <p style="text-align: center;">9J07F2C003DA</p>	1	9J06 PJG1 XX	

## 4. Other

### 4.1 Disassembly/Adjustment prohibited items

#### A. Paint-locked screws

##### NOTE

- To prevent loose screws, a screw lock in blue or green series color is applied to the screws.
- The screw lock is applied to the screws that may get loose due to the vibrations and loads created by the use of machine or due to the vibrations created during transportation.
- If the screw lock coated screws are loosened or removed, be sure to apply a screw lock after the screws are tightened.

#### B. Red-painted screws

##### NOTE

- The screws which are difficult to be adjusted in the field are painted in red in order to prevent them from being removed by mistake.
- Do not remove or loosen any of the red-painted screws in the field. It should also be noted that, when two or more screws are used for a single part, only one representative screw may be marked with the red paint.

#### C. Variable resistors on board

##### NOTE

- Do not turn the variable resistors on boards for which no adjusting instructions are given in Adjustment/Setting.

#### D. Removal of PWBs

##### CAUTION

- When removing a circuit board or other electrical component, refer to “Handling of PWBs” and follow the corresponding removal procedures.
- The removal procedures given in the following omit the removal of connectors and screws securing the circuit board support or circuit board.
- Where it is absolutely necessary to touch the ICs and other electrical components on the board, be sure to ground your body.



## 4.2 Disassembly/Assembly/Cleaning list (Other parts)

### 4.2.1 Disassembly/Assembly parts list

No.	Section	Part name	Ref. page
1	Exterior parts	Feed cover	P.16
2		Front cover	P.17
3		Rear cover	P.18
4		Document feed tray front cover	P.19
5	Unit	Reverse automatic document feeder	P.19
6	Board and etc.	DF control board	P.21
7		Document width detection variable resistor	P.21
8	Others	Stamp unit	P.24
9		Stamp	P.25

## 4.3 Disassembly/Assembly procedure

### 4.3.1 Feed cover

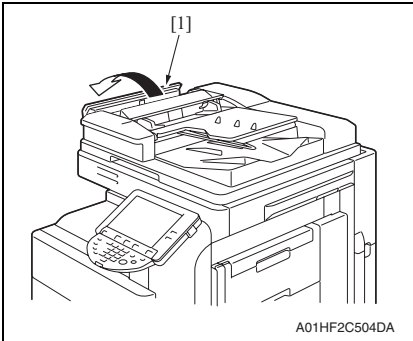

1. Open the transportation cover [1].

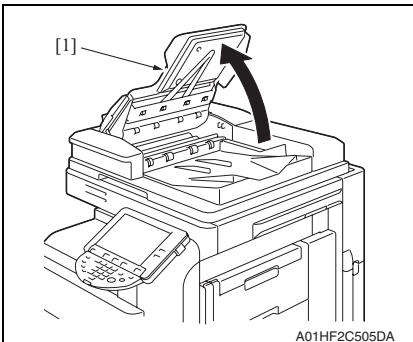

2. Lift up the document feed tray [1].

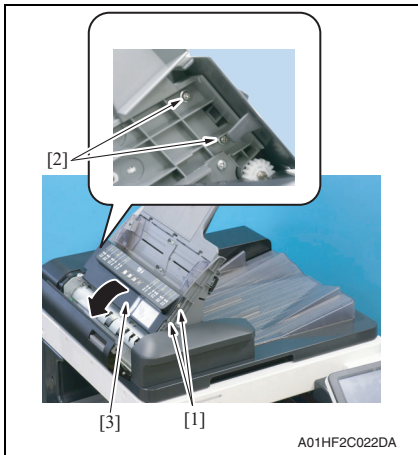

3. Remove two shoulder screws [1] and two screws [2].
4. Open the feed cover [3].

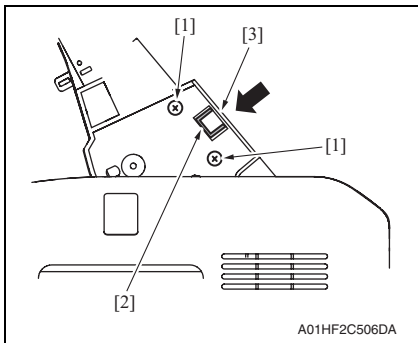

**NOTE**

- In the reinstallation steps, when tightening two screws [1], press the feed cover [3] in the direction of the arrow so as not to leave a clearance between the top of the protrusion from the surface of the feed cover and the bottom of the indentation [2].

**4.3.2 Front cover**

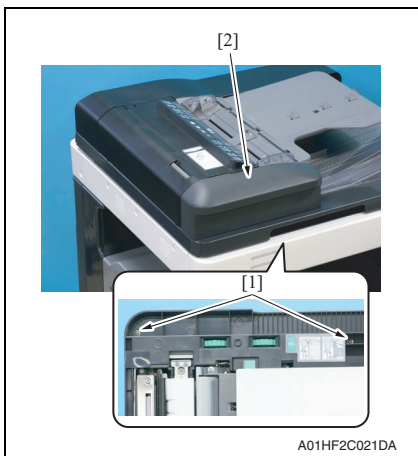

1. Open the reverse automatic document feeder.
2. Remove two screws [1] and remove the front cover [2].

### 4.3.3 Rear cover

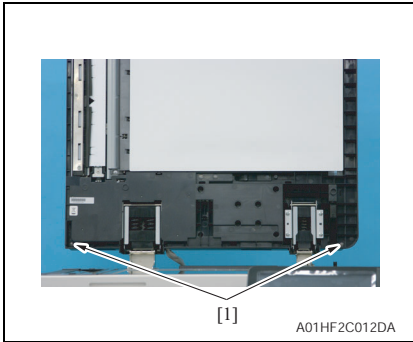

1. Open the reverse automatic document feeder.

#### NOTE

- If the reverse automatic document feeder is set to be lifted up at angles up to 60 degrees due to the set position of the stopper for the hinge, change the set position to the lower side so that the reverse automatic document feeder can be opened completely.

2. Remove two screws [1].

3. Open the transportation cover.
4. Lift up the document feed tray.

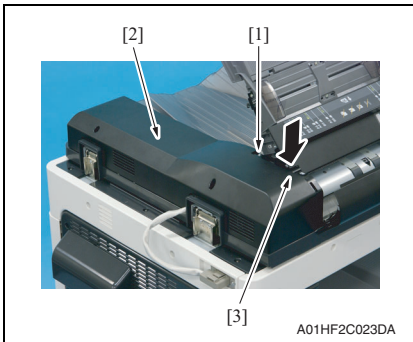

5. Remove the screw [1] and remove the rear cover [2].

#### NOTE

- Be sure to press down part [3] in the picture to prevent any damage when removing the rear cover.

#### A. Reinstallation procedure

1. Open the transportation cover.
2. Lift up the document feed tray.

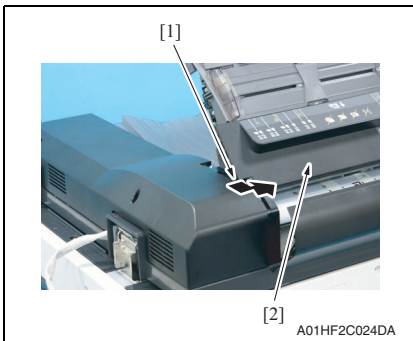

3. Press down part [1] in the picture until it slides under the feed cover [2].

#### NOTE

- Be careful not to damage the rear cover.

4. Install the rear cover tightening three screws.

### 4.3.4 Document feed tray front cover

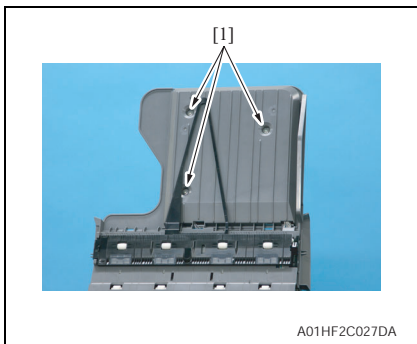

1. Lift up the document feed tray.
2. Remove three screws [1].

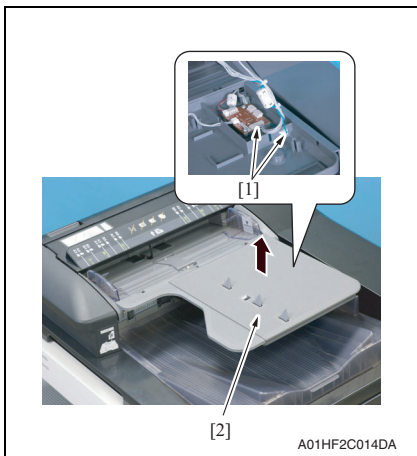

3. Disconnect two connectors [1] and remove the document feed tray front cover [2].

### 4.3.5 Reverse automatic document feeder

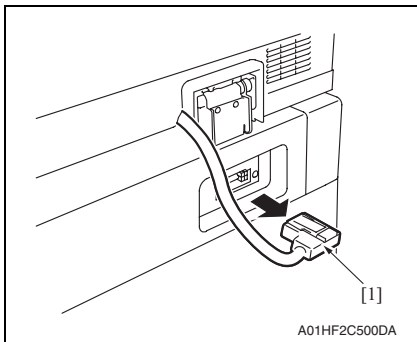

1. Disconnect the connector [1] of the reverse automatic document feeder from the main body.

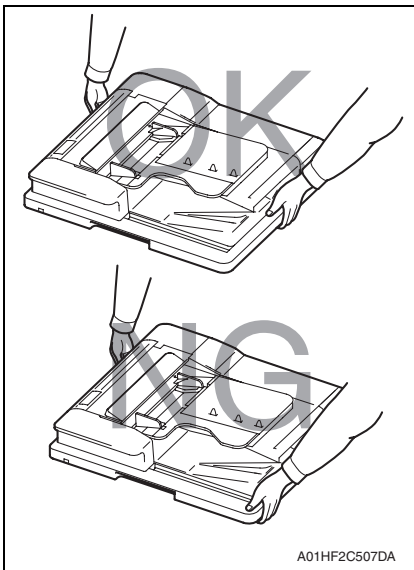
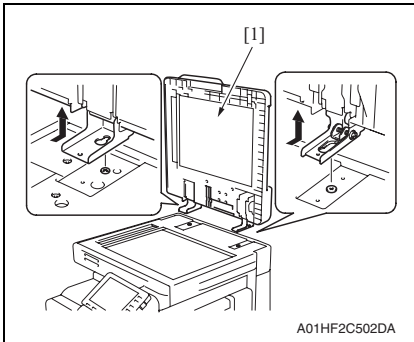
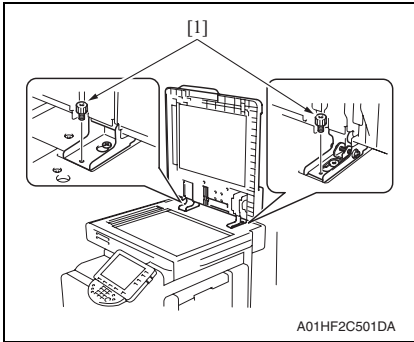

2. Open the reverse automatic document feeder.

**NOTE**

- If the reverse automatic document feeder is set to be lifted up at angles up to 60 degrees due to the set position of the stopper for the hinge, change the set position to the lower side so that the reverse automatic document feeder can be opened completely.

3. Remove two screws [1].
4. Remove the reverse automatic document feeder [1].

**NOTE**

- When carrying the reverse automatic document feeder, be sure to hold onto the specified positions. The feeder main body can be distorted if held at inappropriate positions.



### 4.3.6 DF control board

1. Remove the rear cover.  
[See P.18](#)

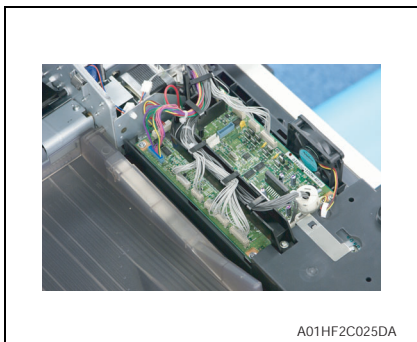

2. Disconnect all the fifteen connectors from the DF control board.

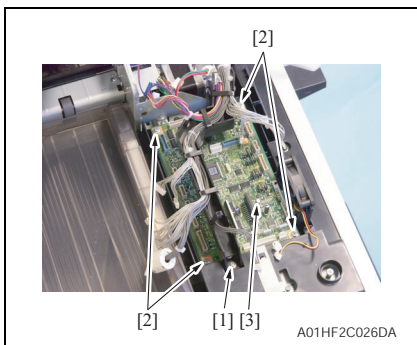

3. Remove the screw [1].
4. Remove four screws [2] and remove the DF control board [3].

#### NOTE

- **Be sure to perform the following operation when the DF control board is replaced.**
5. Replace the EEPROM.
  6. Upgrade the firmware.  
[See P.50 of the main body service manual.](#)

### 4.3.7 Document width detection variable resistor

1. Open the feed cover.  
[See P.16](#)

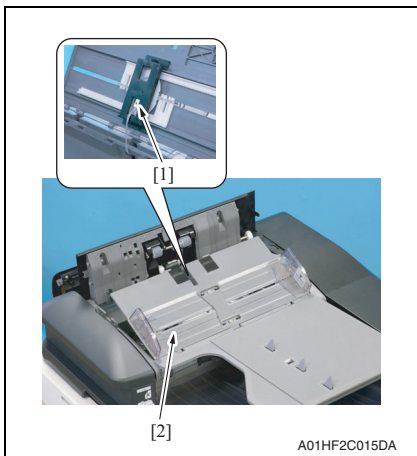

2. Disconnect the connector [1] and remove the document width detection variable resistor cover [2].

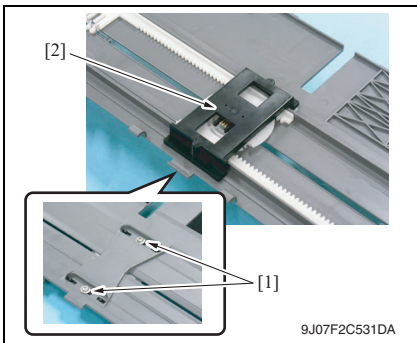

3. Remove two screws [1] and remove the document width detection variable resistor [2].

**A. Reinstallation procedure**

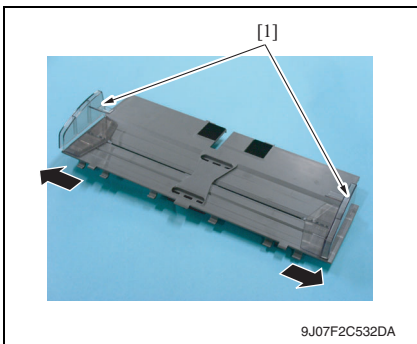

1. Open the side edge stop [1] of the original feed tray.

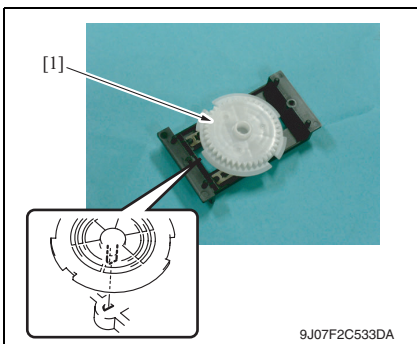

2. Reinstall the gear [1].

**NOTE**

- Note the mounting position of the gear and the document width detection variable resistor.

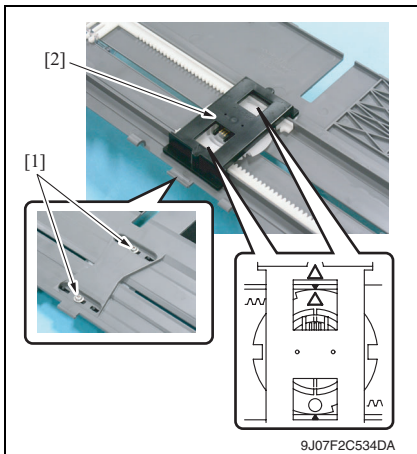

3. Use two screws [1] to install the document width detection variable resistor [2].

**NOTE**

- **Install the gear and rack gear by aligning the arrows.**
4. Connect the connector.
  5. Install the document width detection variable resistor cover and turn on the main power switch.

**NOTE**

- **Be sure to perform the following operation when the document width detection variable resistor is replaced.**
6. Perform document width detection adjustment.  
[See P.32](#)
  7. Turn OFF the main power switch and turn it ON again and check whether size detection operates normally.



### 4.3.8 Replacing the stamp unit

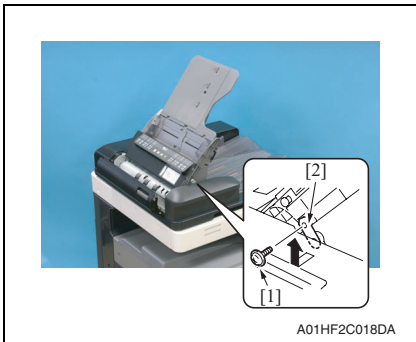

1. Open the transportation cover.
2. Lift up the document feed tray.
3. Remove the screw [1] and the mounting plate [2].

**NOTE**

- Be sure to hold the document feed tray to prevent the tray from falling down while removing the mounting plate.

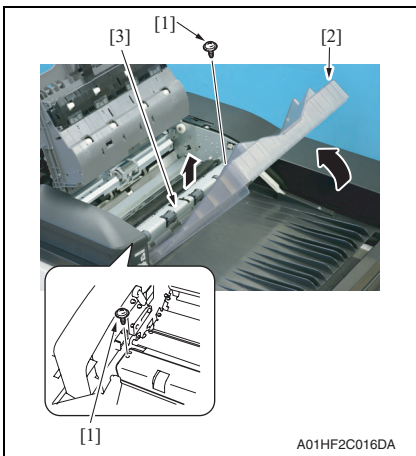

4. Remove two screws [1] and remove the plate cover [3] while holding up the exit tray [2].

**NOTE**

- Take care not to raise the exit tray too much. The stopper may come off.

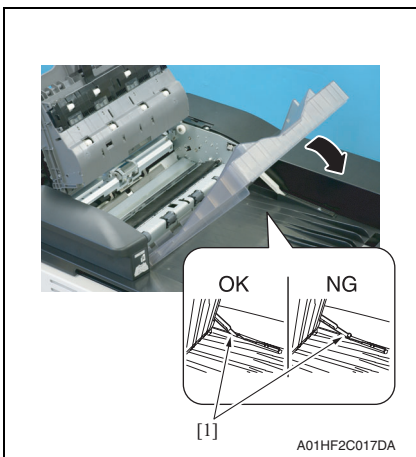

**NOTE**

- When lowering the exit tray, check that the stopper [1] fits under the plate spring.

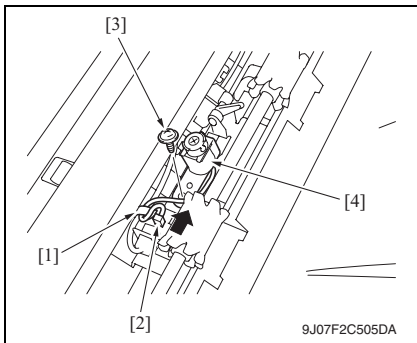

5. Remove the cord clamp [1] and disconnect the connector [2].
6. Remove the screw [3] and remove the stamp unit [4].

### 4.3.9 Replacing the stamp

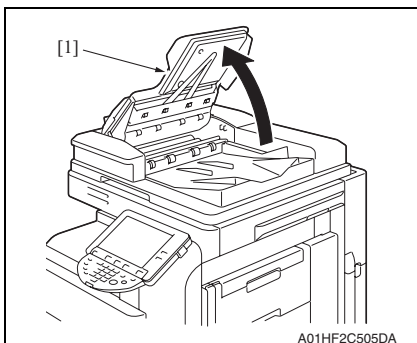

1. Lift up the document feed tray [1].

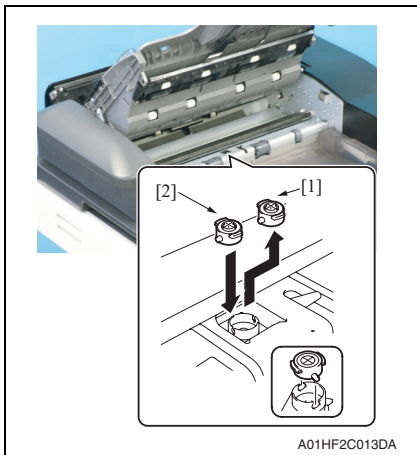

2. Remove the used stamp [1] and install the new stamp of replacement [2].

#### NOTE

- **Align the round pin of the stamp with the slit in the stamp unit side.**

Blank Page

# Adjustment/Setting

## 5. How to use the adjustment section

- “Adjustment/Setting” contains detailed information on the adjustment items and procedures for this machine.
- Throughout this “Adjustment/Setting,” the default settings are indicated by “ ”.

### Advance checks

Before attempting to solve the customer problem, the following advance checks must be made. Check to see if:

- The power supply voltage meets the specifications.
- The power supply is properly grounded.
- The machine shares the power supply with any other machine that draws large current intermittently (e.g., elevator and air conditioner that generate electric noise).
- The installation site is environmentally appropriate: high temperature, high humidity, direct sunlight, ventilation, etc.; levelness of the installation site.
- The original has a problem that may cause a defective image.
- The density is properly selected.
- The original glass, slit glass, or related part is dirty.
- Correct paper is being used for printing.
- The units, parts, and supplies used for printing (developer, PC drum, etc.) are properly replenished and replaced when they reach the end of their useful service life.
- Toner is not running out.

### CAUTION

- **Be sure to unplug the power cord of the machine before starting the service job procedures.**
- **If it is unavoidably necessary to service the machine with its power turned ON, use utmost care not to be caught in the scanner cables or gears of the exposure unit.**
- **Special care should be used when handling the fusing unit which can be extremely hot.**
- **The developing unit has a strong magnetic field. Keep watches and measuring instruments away from it.**
- **Take care not to damage the PC drum with a tool or similar device.**
- **Do not touch IC pins with bare hands.**

## 6. Service Mode

### 6.1 Service Mode setting procedure

See P.338 of the main body service manual.

### 6.2 ADF setting procedure

#### 6.2.1 Original Stop Position

Functions	<ul style="list-style-type: none"> <li>To manually adjust the original stop position and the read position in each of the ADF modes.</li> </ul>
Use	<ul style="list-style-type: none"> <li>When the result is Unable in the automatic adjustment of the original stop position.</li> </ul>
Setting/ procedure	P.40

#### 6.2.2 Registration Loop Adj.

Functions	<ul style="list-style-type: none"> <li>To adjust the length of the loop to be formed in paper before the registration rollers.</li> </ul>
Use	<ul style="list-style-type: none"> <li>When an original misfeed or skew occurs.</li> </ul>
Adjustment instructions	<ul style="list-style-type: none"> <li>The loop value increases by the entered + value and decreases by the entered - value.</li> </ul>
Adjustment range	<ul style="list-style-type: none"> <li>The default setting is 0.</li> <li>Adjustable range: -5 mm to + 5 mm (in 1-mm increments)</li> </ul>
Setting/ procedure	<ol style="list-style-type: none"> <li>Call the Service Mode to the screen.</li> <li>Touch [ADF].</li> <li>Touch [Registration Loop Adj].</li> <li>Select either [1-Side] or [Second Side] for the adjustment.</li> <li>Press the clear key and change the setting value using the 10-key pad. (Press the [+/-] key to change the +/- code.)</li> <li>Touch [END].</li> <li>Touch [Exit] on the Service Mode screen.</li> <li>Turn OFF the main power switch, wait for 10 sec., then turn the switch ON.</li> </ol>

#### 6.2.3 Auto Stop Position Adjustment

##### A. Sub Scanning Direction 1-Side

Functions	<ul style="list-style-type: none"> <li>To automatically adjust the read position for the Sub Scanning Direction 1-Side.</li> <li>To check skew feed.</li> </ul>
Use	<ul style="list-style-type: none"> <li>When ADF has been replaced.</li> </ul>
Setting/ procedure	P.36

##### B. Sub Scanning Direction 2-Side

Functions	<ul style="list-style-type: none"> <li>To automatically adjust the read position for the Sub Scanning Direction 2-Side.</li> </ul>
Use	<ul style="list-style-type: none"> <li>When ADF has been replaced.</li> </ul>
Setting/ procedure	P.38

**C. Main Scanning Direction**

Functions	<ul style="list-style-type: none"> <li>To automatically adjust the read position in the Main Scanning Direction.</li> </ul>
Use	<ul style="list-style-type: none"> <li>When ADF has been replaced.</li> </ul>
Setting/ procedure	P.39

**6.2.4 Paper Passage**

Functions	<ul style="list-style-type: none"> <li>To check for paper passage through the ADF in each of the ADF modes.</li> </ul>
Use	<ul style="list-style-type: none"> <li>Used for checking the document path for any abnormal condition when a document misfeed occurs.</li> </ul>
Setting/ procedure	<p>&lt;Procedure&gt;</p> <ol style="list-style-type: none"> <li>Call the Service Mode to the screen.</li> <li>Touch [ADF].</li> <li>Touch [Paper Passage].</li> <li>Select a paper passage mode to be tested from [1-Sided No Detect], [1-Sided Mixed Org.], [2-Sided], or [AMS Mixed Org.].</li> <li>Set the original in the feed tray.</li> <li>The Start key color changes from orange to blue.</li> <li>Press the Start key. The operation starts.</li> </ol> <p><b>NOTE</b></p> <ul style="list-style-type: none"> <li><b>After starting the operation by pressing the Start key, if the Start key is pressed during the operation, the operation will be suspended. Then, if the Start key is pressed again during the suspension, the operation will be resumed.</b></li> <li><b>If the Stop key is pressed during the test operation, the test will be forced to end.</b></li> <li><b>If there is no Original set in the feed Tray, the Start key will not work.</b></li> <li><b>All Originals set in the feed Tray are passed through. Upon the completion of all Originals passed through, the Paper Through Test ends.</b></li> </ul>

### 6.2.5 Sensor Check

Functions	• To check sensors on the paper path.
Use	• When a document misfeed occurs.

#### A. Procedure

1. Call the Service Mode to the screen.  
[See P.338 of the main body service manual.](#)
2. Touch [ADF].
3. Touch [Sensor Check].
4. Operate the sensor to check by using paper or the like, and check the screen display.  
(Paper detected: 1, No paper detected: 0)

#### B. Sensor check screen

- This is only typical screen which may be different from what are shown on each individual main body.

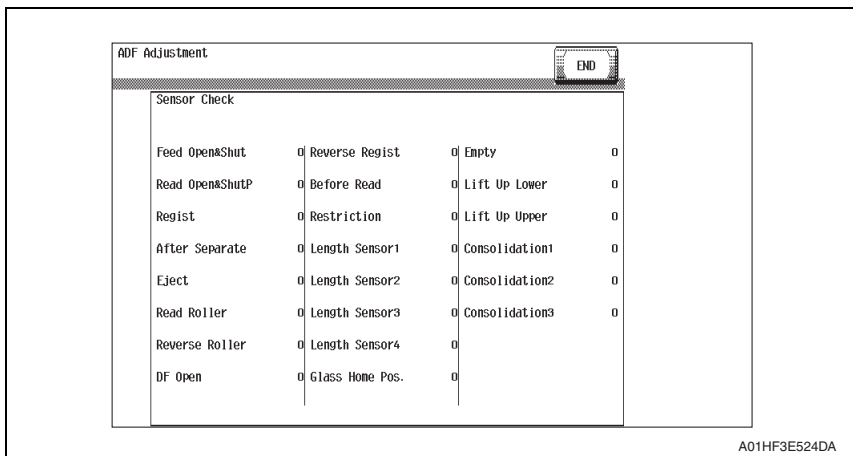

**C. Sensor check list**

Symbol	Panel display	Part/Signal name	Operation characteristics/ panel display	
			1	0
PS1	Feed Open&Close	Feed open/close sensor	Open	Close
PS2	Read Open&Close	Read open/close sensor	Open	Close
PS3	Regist	Registration sensor	Paper present (Blocked)	Paper not present (Unblocked)
PS4	After Separate	After separate sensor	Paper present (Unblocked)	Paper not present (Blocked)
PS5	Eject	Exit sensor	Paper present (Unblocked)	Paper not present (Blocked)
PS6	Read Roller	Read roller sensor	Pressure (Blocked)	Retraction (Unblocked)
PS7	Reverse Roller	Reverse roller sensor	Pressure (Blocked)	Retraction (Unblocked)
RS201	DF Open	Original cover sensor	Open	Close
PS8	Reverse Regist	Reverse registration sensor	Paper present (Blocked)	Paper not present (Unblocked)
PS9	Before Read	Before read sensor	Paper present (Blocked)	Paper not present (Unblocked)
VR1	Restriction Board Position	Document width detection variable resistor	Analog value	
PS10	Length Sensor1	Length sensor1	Paper present	Paper not present
PS11	Length Sensor2	Length sensor2	Blocked	Unblocked
PS12	Length Sensor3	Length sensor3	Paper present	Paper not present
PS13	Length Sensor4	Length sensor4	Paper present	Paper not present
PS203	Glass Home Pos.	Glass home sensor	At home (Unblocked)	Out of home (Blocked)
PS14	Empty	Empty sensor	Paper present	Paper not present
PS16	Lift Up Lower	Lift up lower sensor	Unblocked	Blocked
PS15	Lift Up Upper	Lift up upper sensor	Blocked	Unblocked
PS19	Mixed Sensor1	Mixed sensor1	Paper present	Paper not present
PS18	Mixed Sensor2	Mixed sensor2	Paper present	Paper not present
PS17	Mixed Sensor3	Mixed sensor3	Paper present	Paper not present



### 6.2.6 Original Tray Width

Functions	<ul style="list-style-type: none"> <li>To set the values of maximum (A3 position) and minimum (B6 position) widths on the document width detection variable resistor.</li> </ul>
Use	<ul style="list-style-type: none"> <li>When an original misfeed occurs.</li> <li>When an original size detection error occurs.</li> </ul>
Setting/procedure	P.44

### 6.2.7 Read Pos Adj

Functions	<ul style="list-style-type: none"> <li>To adjust the original read position.</li> </ul>
Use	<ul style="list-style-type: none"> <li>When the first/second carriage, the scanner wire, the scanner assy, the original glass moving unit, and/or the glass step sheet have been replaced.</li> </ul>
Setting/procedure	P.46

### 6.2.8 Feed Zoom

Functions	<ul style="list-style-type: none"> <li>To adjust the feed zoom of ADF in the feeding direction.</li> </ul>
Use	<ul style="list-style-type: none"> <li>When ADF has been replaced.</li> </ul>
Setting/procedure	P.49

### 6.2.9 Scanning Light Adjustment

Functions	<ul style="list-style-type: none"> <li>To adjust the scanning light of ADF.</li> </ul>
Use	<ul style="list-style-type: none"> <li>When the original glass moving unit has been replaced.</li> <li>Used for adjusting the difference in the scanning lights between scanning from the original glass and scanning from the ADF original glass.</li> </ul>
Setting/procedure	<ul style="list-style-type: none"> <li>Adjustable range: -2 to + 2 (1 step)</li> <li>1. Call the Service Mode to the screen.</li> <li>2. Touch [ADF].</li> <li>3. Touch [Scanning Light Adjustment].</li> <li>4. Select a color by pressing [Red], [Green], or [Blue].</li> <li>5. Press the value using the [+]/[-] key.</li> </ul> <p><b>NOTE</b></p> <ul style="list-style-type: none"> <li>It is recommended that the scanning light adjustment should be made by the same steps for all the three colors of red, green, and blue.</li> <li>6. Touch [END].</li> <li>7. Touch [Exit] on the Service Mode screen.</li> <li>8. Turn OFF the main power switch, wait for 10 sec., then turn the switch ON.</li> </ul>

## 7. Mechanical adjustment

### 7.1 Adjusting the height

**NOTE**

Make this adjustment after any of the following procedures has been performed.

- When the reverse automatic document feeder has been reinstalled.

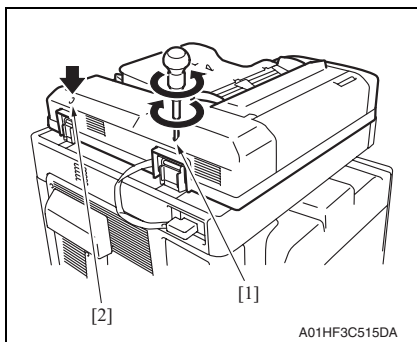
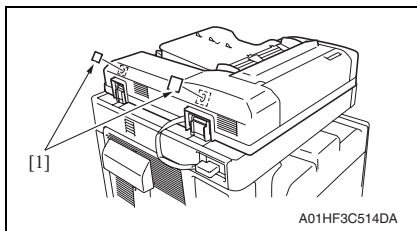
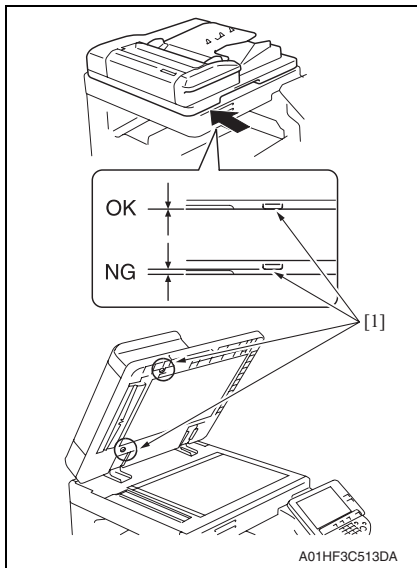

1. Check the clearance between the upper face of scanner and the protrusion [1] on the reverse automatic document feeder side (2 spots, front/back).

**NOTE**

- There must be no clearance between the protrusion [1] on the reverse automatic document feeder and the upper face of scanner.
2. If there is any clearance, the following adjustment is needed.

3. Remove the label [1].

4. Remove the clearance by turning the adjusting screw [1].  
 Clockwise rotation:  
 Lifting up the rear side  
 Counterclockwise rotation:  
 Lowering the rear side
5. Use the adjusting screw [2] when further adjustment is needed.  
 Clockwise rotation:  
 Lifting up the rear side  
 Counterclockwise rotation:  
 Lowering the rear side
6. Affix again the labels removed in step 3.

### 7.2 Adjusting skew feed

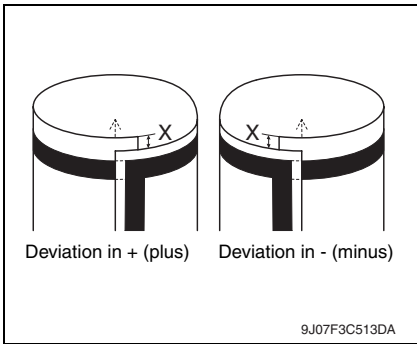

1. Check how the edges of the chart are misaligned. The amount of the deviation of the chart will be X.

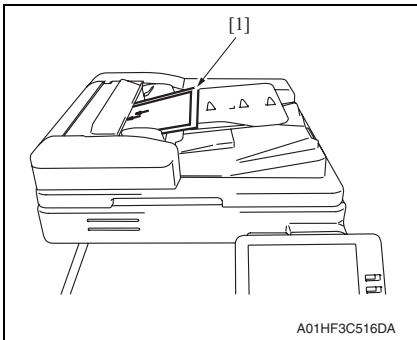

2. Place the chart [1] in the document feed tray (with the side having an arrow facing up).

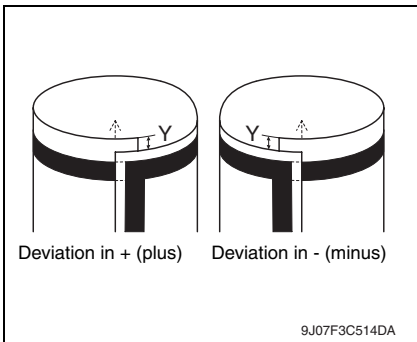

3. Make copies 5 times repeatedly in single side mode.
4. Fold all 5 sample copies as illustrated and check for any deviation. Deviation on the sample will be Y.
5. Obtain the difference between the deviation of the chart and the deviation of the sample. Difference of the deviation =  $Y - X$   
Specifications:  $0 \pm 2$  mm
6. If the difference of the deviation does not fall within the specified range, perform the following adjustment.

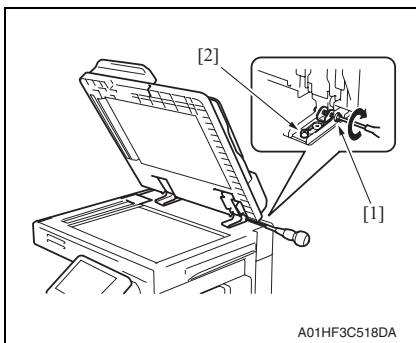
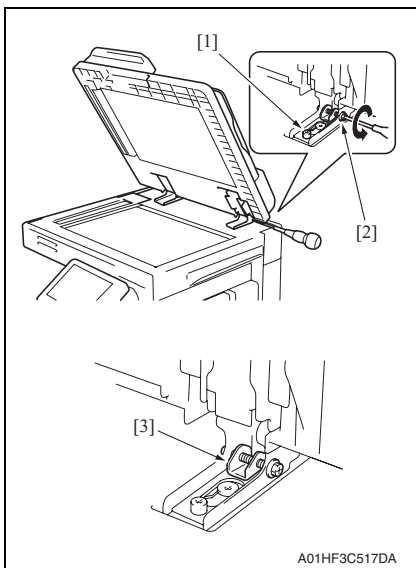

7. Loosen the mounting screw [1] on the right hinge viewed from the front.
8. When the difference of the deviation is + (plus), turn the screw [2] counterclockwise to adjust.

#### NOTE

- When turning the screw, be sure not to raise the reverse automatic document feeder until in an upright position.
- When the adjusting plate [3] is set far left, do not tighten any further.
- To prevent the adjustment screw [2] breakage, be sure to follow the above instructions.

9. When the difference of the deviation is - (minus), turn the screw [1] clockwise to adjust.
10. After the adjustment is completed, tighten the mounting screw [2] on right side hinge securely with screwdriver.

### 7.3 Original Stop Position

- Adjustment of the document stop position is made automatically and manually (by entering numbers). The following adjustment is made in the Service Mode.

#### NOTE

- Before performing this adjustment, the feed zoom adjustment needs to be complete.

See P.49

#### A. Auto adjust: Sub Scanning Direction 1-Side Stop Position

1. Call the Service Mode to the screen.  
See P.338 of the main body service manual.
2. Touch [ADF].
3. Touch [Auto Stop Position Adjustment].

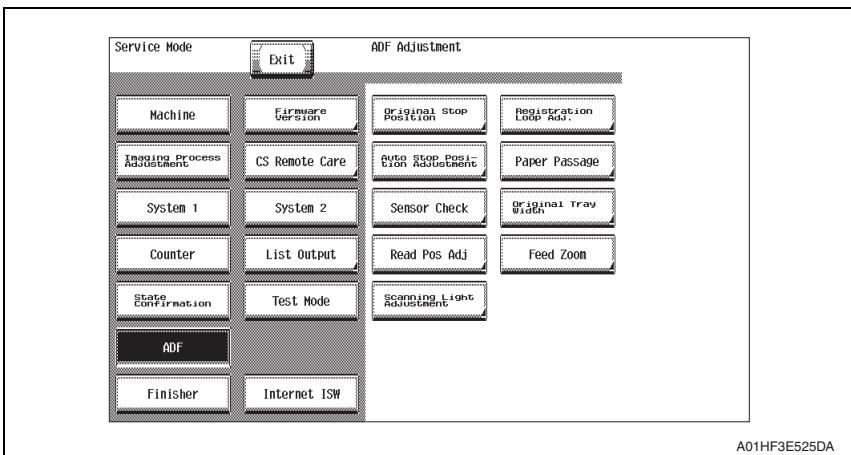

A01HF3E525DA

4. Touch [Sub Scanning Direction 1-Side].

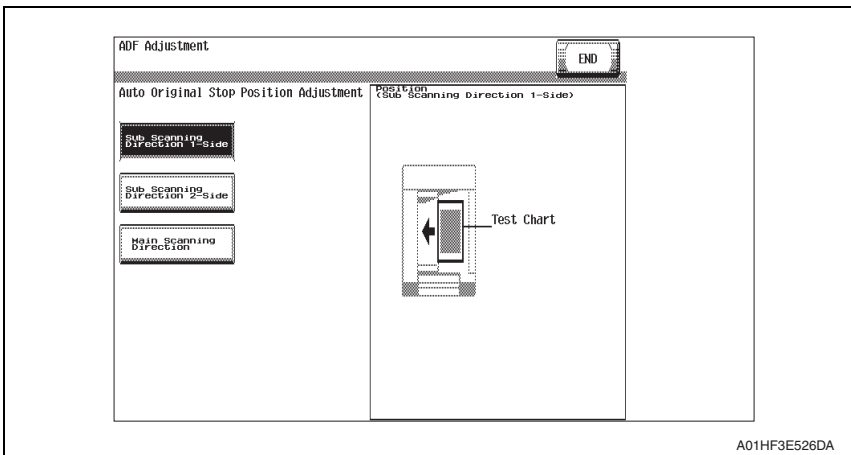

A01HF3E525DA

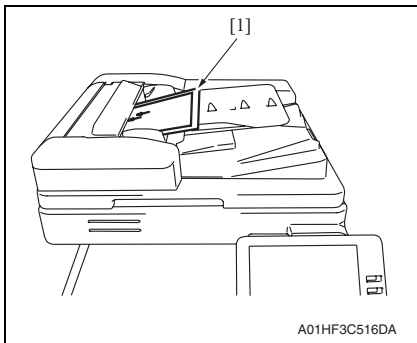

A01HF3C516DA

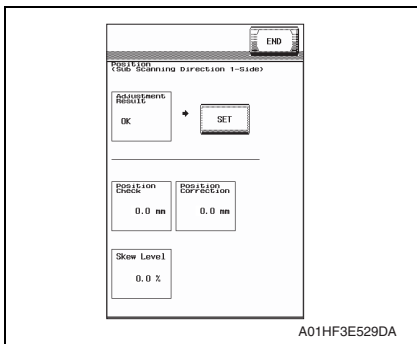

A01HF3E529DA

5. Place the chart [1] in the document feed tray (with the side having an arrow facing up).
6. Press the Start key.
  
7. Make sure that result is OK. Then, touch [SET].
8. Touch [END].
9. Touch [Exit] on the Service Mode screen.
10. Turn OFF the main power switch, wait for 10 sec., then turn the switch ON.

**NOTE**

**If the result is Unable:**

- Check and correct the skew of the document.
- Manually correct the value of [Original Stop Position].  
[See P.40](#)

**B. Auto adjust: Sub Scanning Direction 2-Side Stop Position**

1. Call the Service Mode to the screen.  
[See P.338 of the main body service manual.](#)
2. Touch [ADF].
3. Touch [Auto Stop Position Adjustment].
4. Touch [Sub Scanning Direction 2-Side].

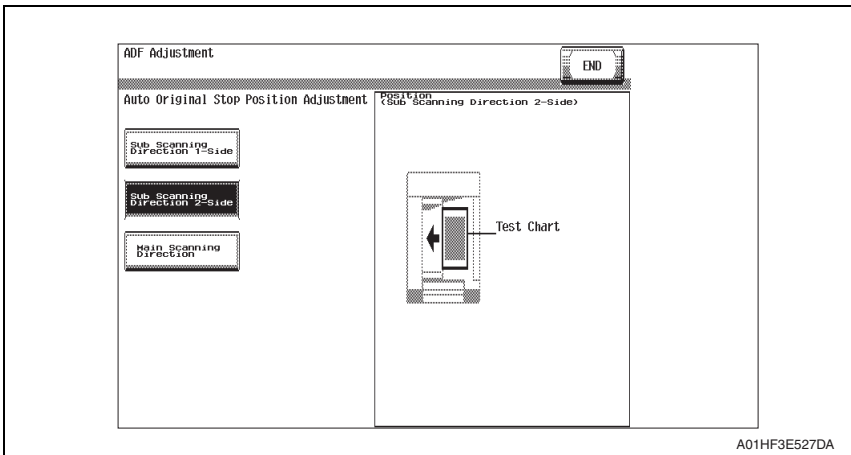

A01HF3E527DA

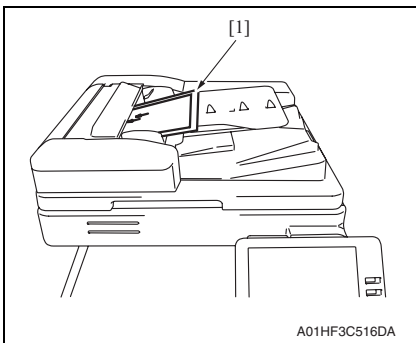

A01HF3C516DA

5. Place the chart furnished with the ADF [1] in the document feed tray.

**NOTE**

- **Make sure that the blank surface of the chart faces up.**

6. Press the Start key.

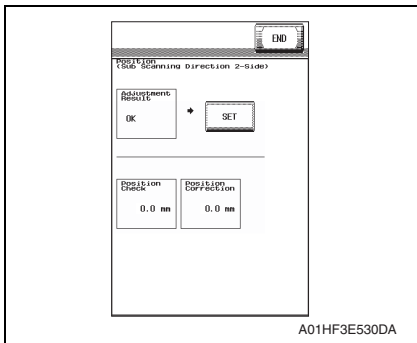

7. Make sure that result is OK. Then, touch [SET].
8. Touch [END].
9. Touch [Exit] on the Service Mode screen.
10. Turn OFF the main power switch, wait for 10 sec., then turn the switch ON.

**NOTE**

**If the result is Unable:**

- Check and correct the skew of the document.
- Manually correct the value of [Original Stop Position].

[See P.40](#)

**C. Auto adjust: Main Scanning Direction Image scan start position**

1. Call the Service Mode to the screen.  
[See P.338 of the main body service manual.](#)
2. Touch [ADF].
3. Touch [Auto Stop Position Adjustment].
4. Touch [Main Scanning Direction].

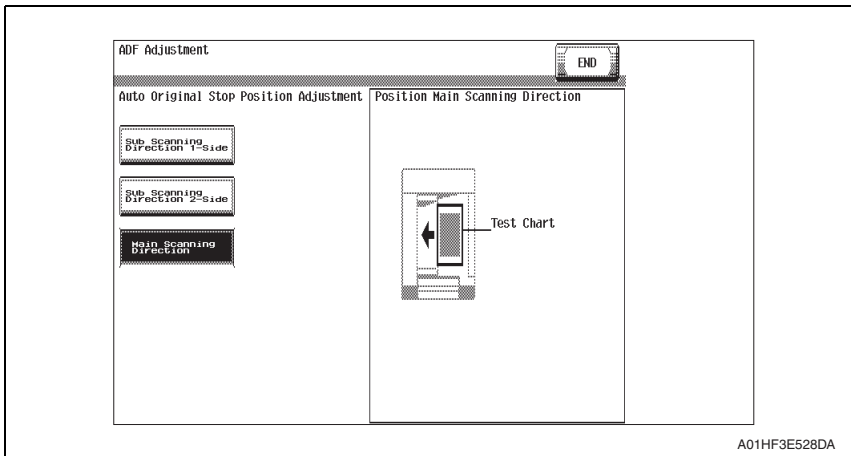



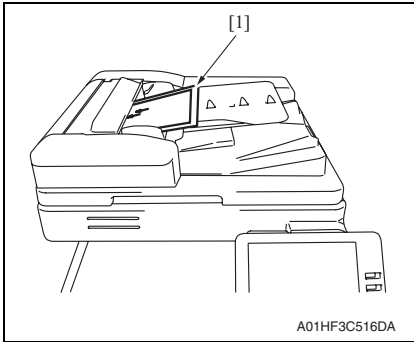

5. Place the chart [1] in the document feed tray (with the side having an arrow facing up).
6. Press the Start key.

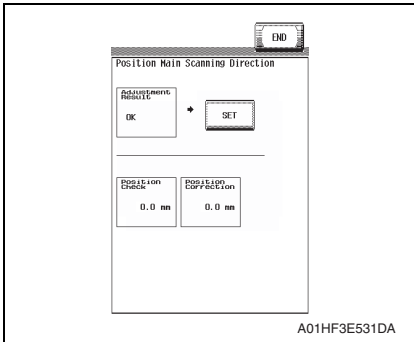

7. Make sure that result is OK. Then, touch [SET].
8. Touch [END].
9. Touch [Exit] on the Service Mode screen.
10. Turn OFF the main power switch, wait for 10 sec., then turn the switch ON.

**NOTE**

**If the result is Unable:**

- Check and correct the skew of the document.
- Manually correct the value of [Original Stop Position].  
[See P.42](#)

**D. Manual adjust: Sub Scanning Direction 1-Sided/2-Sided document stop position adjustment**

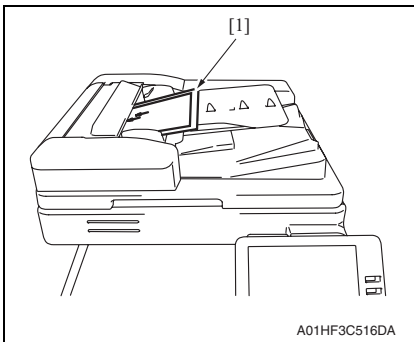

1. Place the chart [1] in the document feed tray (with the side having an arrow facing up).
2. Make a full size copy of the chart.

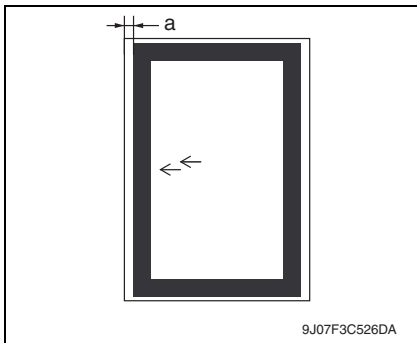

9J07F3C526DA

3. Check that the difference in the widths of a between the chart and the copy sample falls within the specified range.  
Specifications:  $0 \pm 2$  mm

**NOTE**

- In the same way place the chart with the blank side facing up in the document feed tray in the duplex mode and make a copy. Check the difference in the widths of a between the chart and the second sided surface of the copy sample.

4. If the difference in the width of a falls outside the specified range, make the following adjustment.
5. Call the Service Mode to the screen.  
[See P.338 of the main body service manual.](#)
6. Touch [ADF].
7. Touch [Original Stop Position].

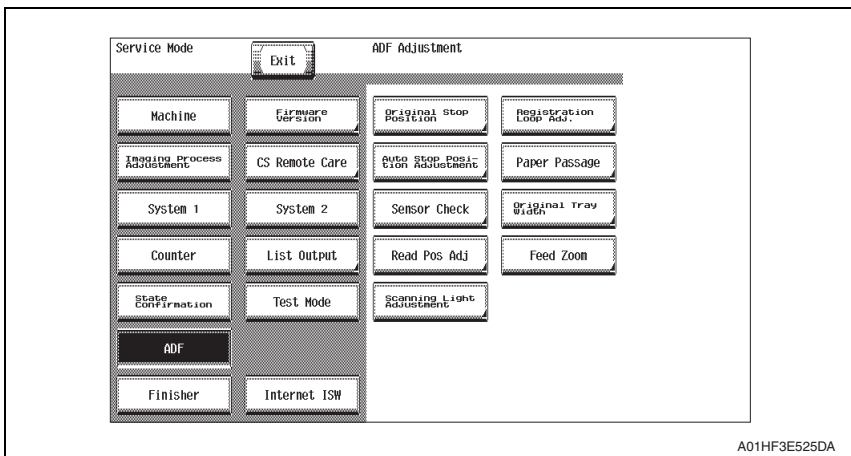

A01HF3E525DA

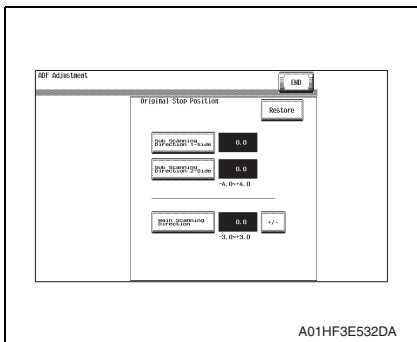

A01HF3E532DA

8. Touch [Sub Scanning Direction 1-Side] or [Sub Scanning Direction 2-Side].
9. Enter the value from the ten-key pad. (Press the [+/-] key to change the +/- code.)
  - Adjustable range: -4.0 mm to + 4.0 mm (in 1-mm increments)
  - If the difference in the widths of a is greater than the specifications, enter the + value.
  - If the difference in the widths of a is smaller than the specifications, enter the - value.

10. Touch [END].
11. Touch [Exit] on the Service Mode screen.
12. Turn OFF the main power switch, wait for 10 sec., then turn the switch ON.
13. Make a copy of the chart again and check that the difference in the widths of a falls within the specified range.

### E. Manual adjust: Main Scanning Direction stop position adjustment

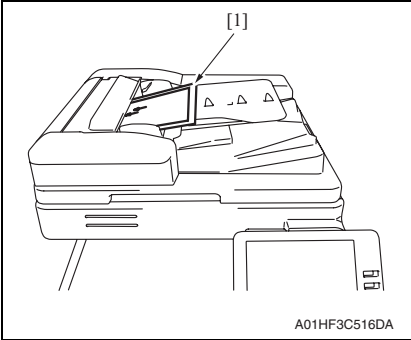

1. Place the chart [1] in the document feed tray (with the side having an arrow facing up).
2. Make a full size copy of the chart.

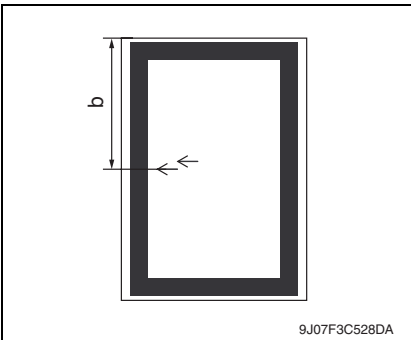

3. Check that the difference in the widths of b between the chart and the copy sample falls within the specified range.  
Specifications:  $0 \pm 2$  mm
4. If the difference in the width of b falls outside the specified range, make the following adjustment.

5. Call the Service Mode to the screen.  
See P.338 of the main body service manual.
6. Touch [ADF].
7. Touch [Original Stop Position].

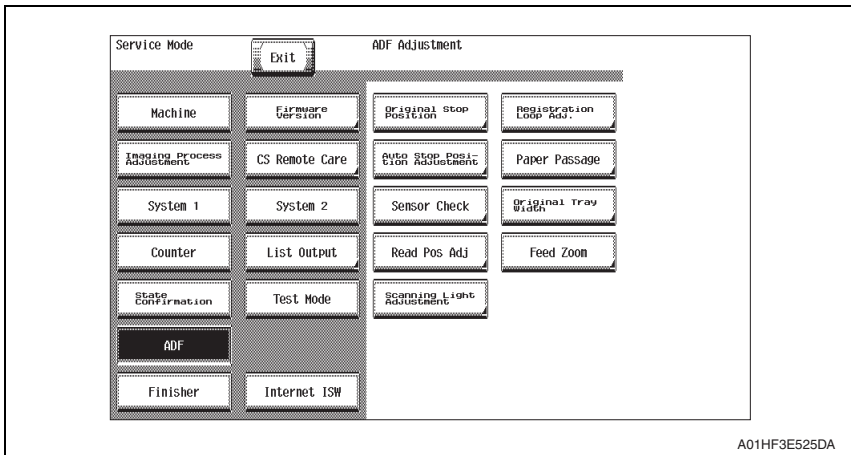

A01HF3E525DA

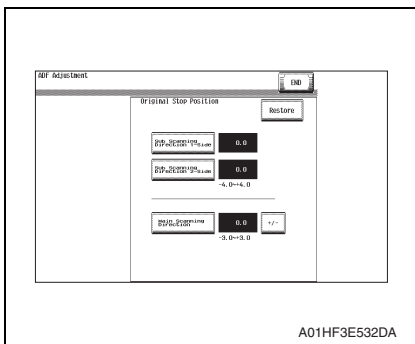

A01HF3E532DA

8. Touch [Main Scanning Direction].
9. Enter the value from the ten-key pad.  
(Press the [+/-] key to change the +/- code.)

  - Adjustable range: -3.0 mm to + 3.0 mm (in 1-mm increments)
  - If the difference in the widths of b is greater than the specifications, enter the + value.
  - If the difference in the widths of b is smaller than the specifications, enter the - value.

10. Touch [END].
11. Touch [Exit] on the Service Mode screen.
12. Turn OFF the main power switch, wait for 10 sec., then turn the switch ON.
13. Make a copy of the chart again and check that the difference in the widths of b falls within the specified range.

### 7.4 Original Tray Width

#### NOTE

Make this adjustment after any of the following procedures has been performed.

- When the document width detection variable resistor has been replaced.
- When the EEPROM has been replaced.

1. Call the Service Mode to the screen.  
[See P.338 of the main body service manual.](#)
2. Touch [ADF].
3. Touch [Original Tray Width].

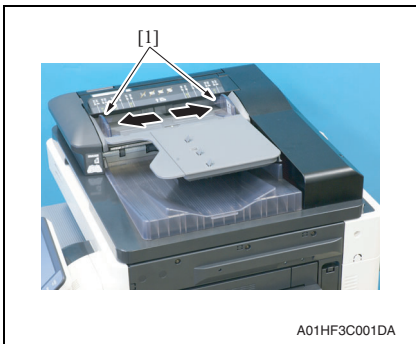
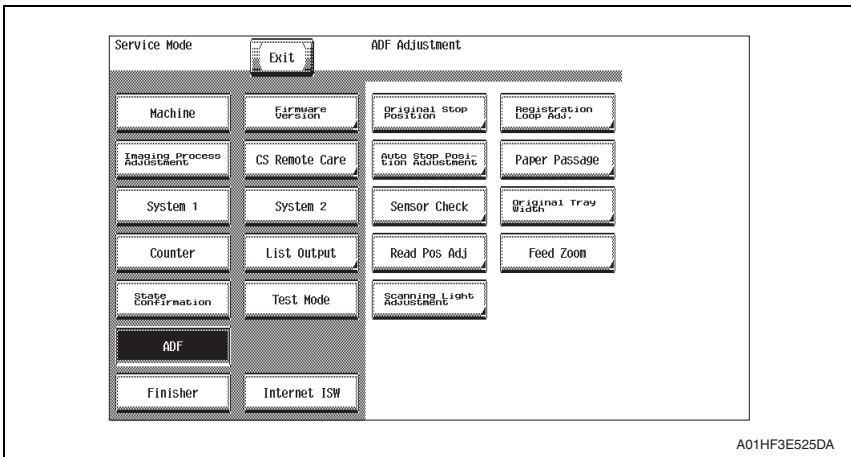

4. Widen the width across the edge guides [1] by sliding them to the "A3" position.

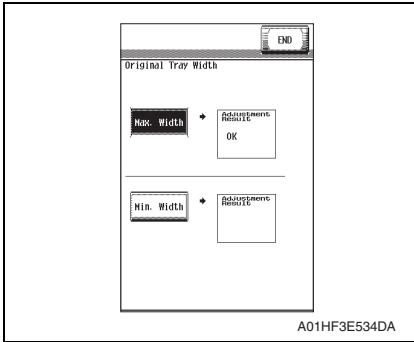

5. Touch [Max. Width].
6. Press the Start key.
7. OK is displayed when the adjustment has been completed.

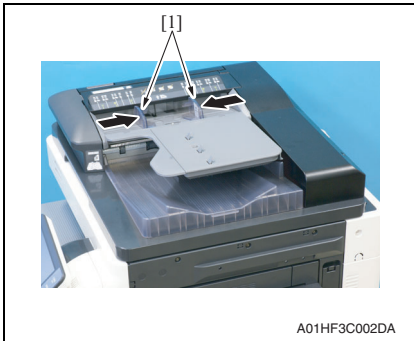

8. Narrow the width across the edge guides [1] by sliding them to the "B6" position.

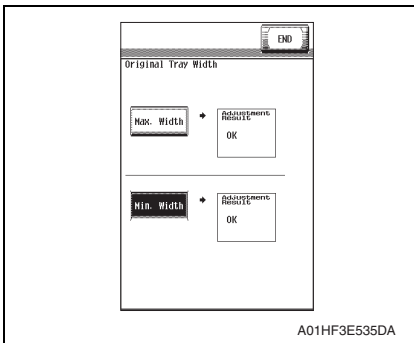

9. Touch [Min. Width].
10. Press the Start key.
11. OK is displayed when the adjustment has been completed.
12. Touch [END].

13. Touch [Exit] on the Service Mode screen.
14. Turn OFF the main power switch, wait for 10 sec., then turn the switch ON.

\* If the result is NG:

- Possible causes includes failure of the document width detection variable resistor, wrong wiring to the volume and failure of the DFCB.

### 7.5 Read Pos Adj

#### NOTE

Make this adjustment after any of the following procedures has been performed.

- When the first/second carriage, the scanner wire, the scanner assy, the original glass moving unit, and/or the glass step sheet have been replaced.

#### A. Auto adjust

1. Call the Service Mode to the screen.  
[See P.338 of the main body service manual.](#)
2. Touch [ADF].
3. Touch [Read Pos Adj].
4. Touch [Auto Adjust].

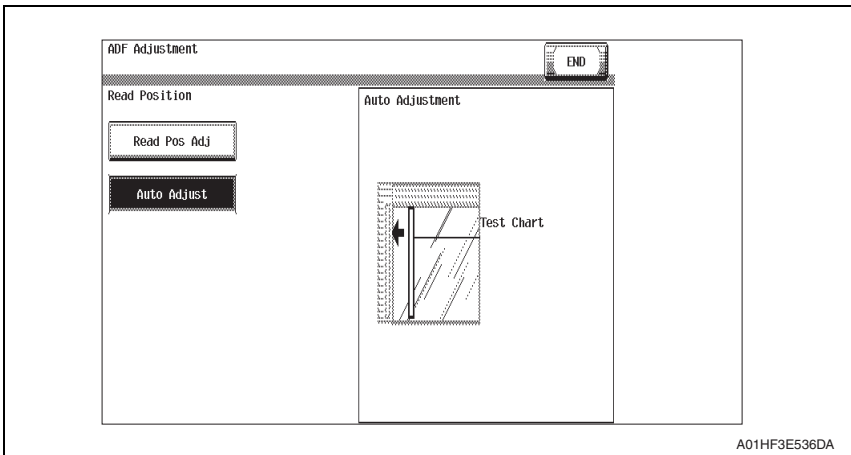

A01HF3E536DA

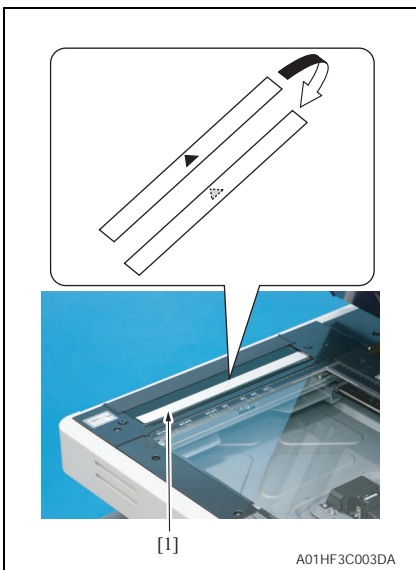

A01HF3C003DA

5. Open the ADF.
6. Place the ADF reading chart [1] so that a triangular mark may become the original glass side (downward) and the pointed tip of the triangle points toward the black sheet on the left side.
7. Press the Start key.

#### NOTE

- Be sure that the ADF reading chart is in position.
- Keep the automatic document feeder open while making the adjustment.

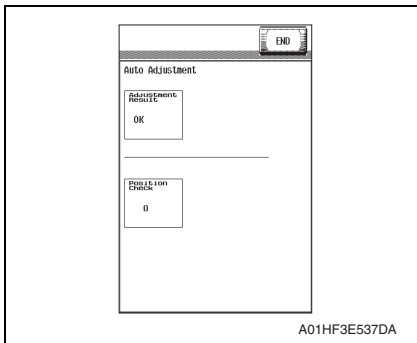

8. Make sure that the result is OK.
9. Touch [END].
10. Touch [Exit] on the Service Mode screen.
11. Turn OFF the main power switch, wait for 10 sec., then turn the switch ON.

**NOTE**

**If the result is Unable:**

- Check that the chart is in the correct place.
- Make the manual adjustment on the [Read Pos Adj] screen.  
See P.47

**B. Manual adjust: Read Pos Adj**

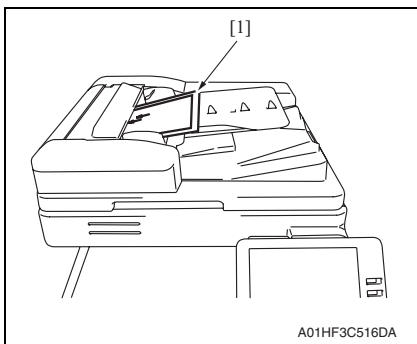

1. Place the chart [1] in the document feed tray (with the side having an arrow facing up).
2. Make a full size copy of the chart.

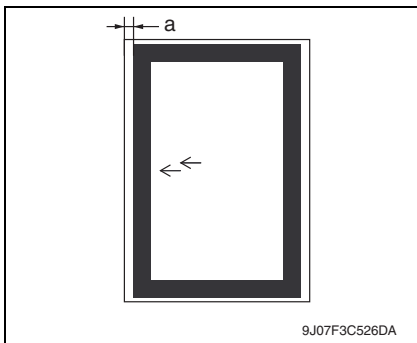

3. Check that the difference in the widths of a between the chart and the copy sample falls within the specified range.  
Specifications:  $0 \pm 1.0$  mm
4. If the difference in the width of a falls outside the specified range, make the following adjustment.

5. Call the Service Mode to the screen.  
See P.338 of the main body service manual.
6. Touch [ADF].



7. Touch [Read Pos Adj].

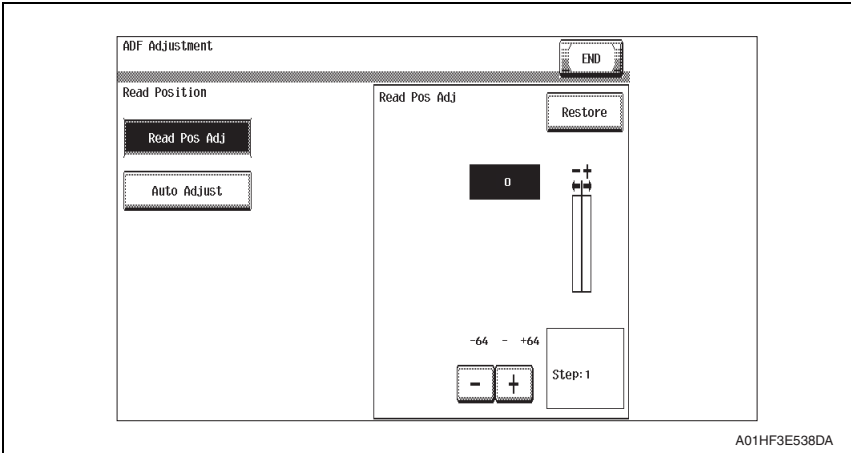

8. Enter the value using the [-]/[+] keys.
  - If the difference in the widths of a is greater than the specifications, enter the - value.
  - If the difference in the widths of a is smaller than the specifications, enter the + value.
9. Touch [END].
10. Touch [Exit] on the Service Mode screen.
11. Turn OFF the main power switch, wait for 10 sec., then turn the switch ON.
12. Make a copy of the chart again and check that the difference in the widths of a falls within the specified range.

### 7.6 Feed Zoom

- Adjustment of the feed zoom is made automatically and manually (by entering numbers). The following adjustment is made in the Service Mode.

#### A. Auto adjust

1. Call the Service Mode to the screen.  
[See P.338 of the main body service manual.](#)
2. Touch [ADF].
3. Touch [Feed Zoom].
4. Touch [Auto Adjust].

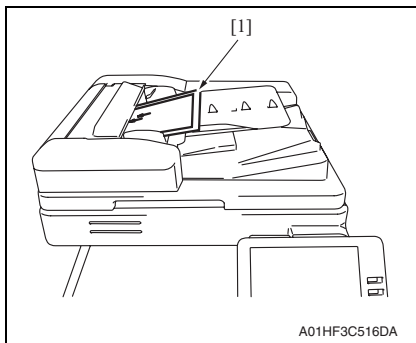
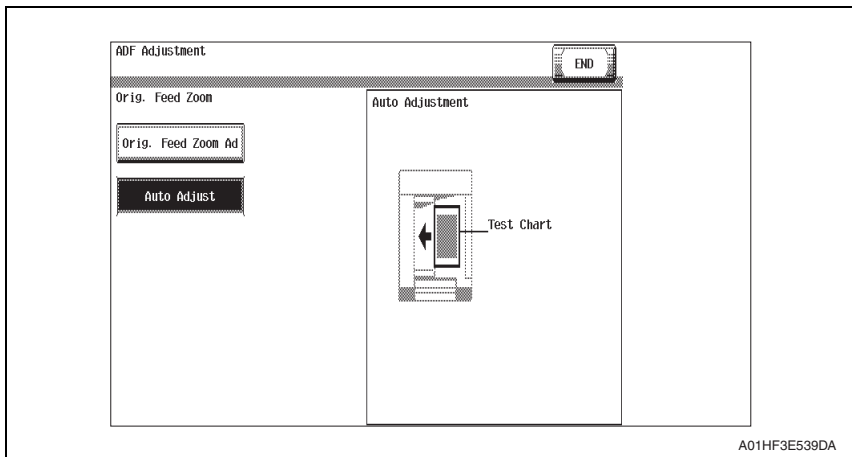

5. Place the chart [1] in the document feed tray (with the side having an arrow facing up).
6. Press the Start key.

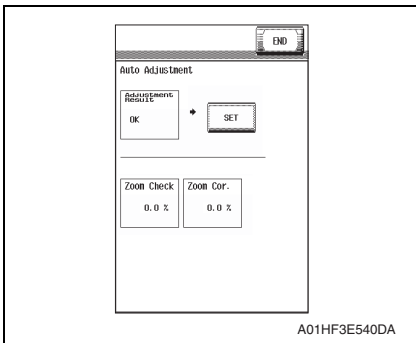

7. Make sure that result is OK. Then, touch [SET].
8. Touch [END].

9. Touch [Exit] on the Service Mode screen.
10. Turn OFF the main power switch, wait for 10 sec., then turn the switch ON.

**B. Manual adjust: Orig. Feed Zoom Adjustment**

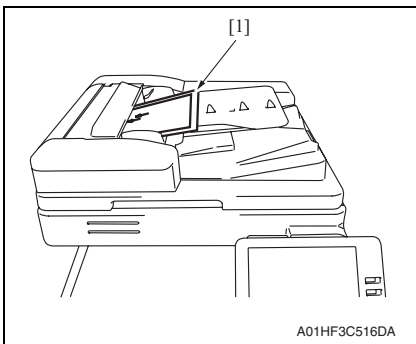

1. Place the chart [1] in the document feed tray (with the side having an arrow facing up).
2. Make a full size copy of the chart.

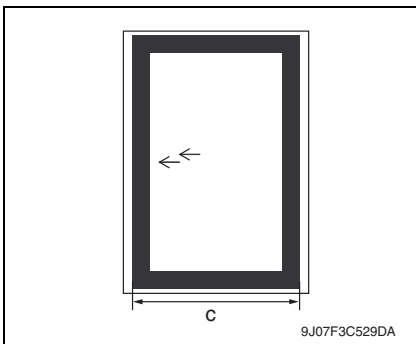

3. Check that the difference in the widths of c between the chart and the copy sample falls within the specified range.  
Specifications:  $0 \pm 1.0$  mm
4. If the difference in the width of c falls outside the specified range, make the following adjustment.

5. Call the Service Mode to the screen.  
See P.338 of the main body service manual.
6. Touch [ADF].
7. Touch [Feed Zoom].
8. Touch [Orig. Feed Zoom Ad].

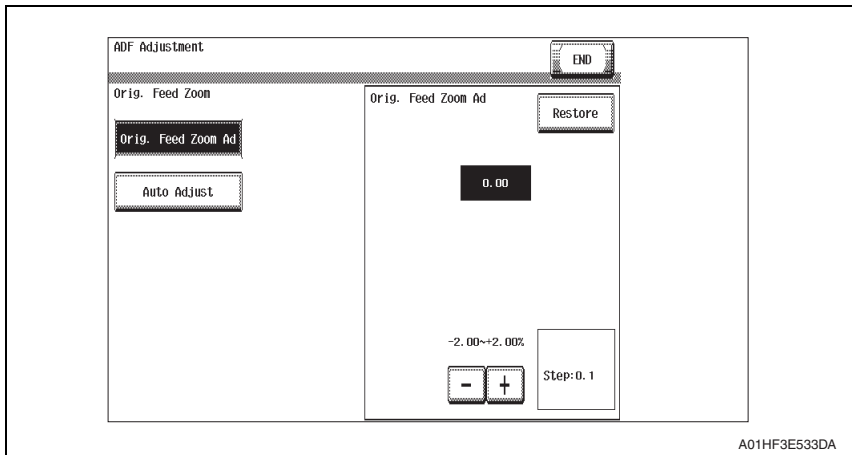

9. Enter the value using the [-]/[+] keys.
  - If the difference in the widths of c is greater than the specifications, enter the - value.
  - If the difference in the widths of c is smaller than the specifications, enter the + value.
10. Touch [END].
11. Touch [Exit] on the Service Mode screen.
12. Turn OFF the main power switch, wait for 10 sec., then turn the switch ON.
13. Make a copy of the chart again and check that the difference in the widths of a falls within the specified range.

Blank Page

# Troubleshooting

## 8. Jam display

### 8.1 Initial check items

- When a paper misfeed occurs, first perform the following initial check items.

Check item	Action
Does paper meet product specifications?	Replace paper.
Is the paper curled, wavy, or damp?	Replace paper. Instruct the user on the correct paper storage procedures.
Is a foreign object present along the paper path, or is the paper path deformed or worn?	Clean the paper path and replace if necessary.
Are rolls/rollers dirty, deformed, or worn?	Clean or replace the defective roll/roller.
Are the edge guide and trailing edge stop at the correct position to accommodate the paper?	Set as necessary.
Are the actuators operating correctly?	Correct or replace the defective actuator.

### 8.2 Misfeed display

- When misfeed occurs, message, misfeed location “Blinking” and paper location “Lighting” are displayed on the touch panel of the main unit.

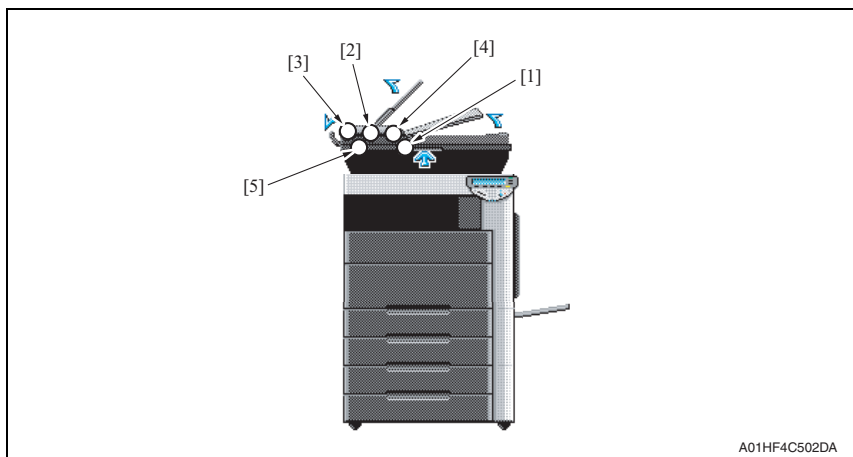

Display	Code	Jam type	Misfeed access location	Action
[1]	6601	Turnover section misfeed	Transportation cover	P.55
[2]	6602	Paper feed section misfeed		P.55
[3]	6603	Transport section misfeed		P.56
[4]	6604	Paper exit section misfeed		P.57
[5]	6605	Image reading section misfeed		P.58
[1][2][3][4][5]	6606	Original feeding interval misfeed		P.59
[1][2][3][4][5]	6607	Remaining paper misfeed		P.59

### 8.2.1 Misfeed display resetting procedure

- Open the corresponding cover, clear the sheet of paper misfed, and close the cover.

### 8.3 Sensor layout

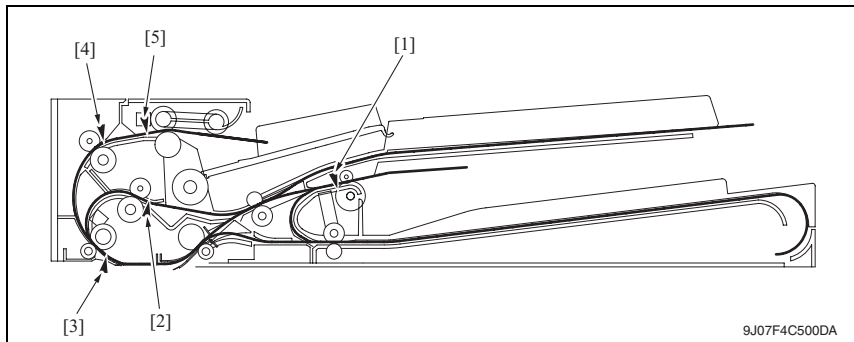

9J07F4C500DA

[1] Exit sensor	PS5	[4] Registration sensor	PS3
[2] Reverse registration sensor	PS8	[5] After separate sensor	PS4
[3] Before read sensor	PS9		

## 8.4 Solution

### 8.4.1 Turnover section misfeed

#### A. Detection timing

Type	Description
Detection of misfeed at turnover section	The before read sensor (PS9) is not turned ON after a lapse of a given time after the reverse registration motion is performed.
	The reverse registration sensor (PS8) is not turned ON after a lapse of a given time after the before read sensor (PS9) is turned OFF.
Detection of paper left in turnover section	The reverse registration sensor (PS8) is not turned OFF after a lapse of a given time after the reverse registration motion is performed.

#### B. Action

Relevant electrical parts	
Switchback roller pressure/retraction motor (M5) Before read sensor (PS9) Reverse registration sensor (PS8)	DF control board (DFCB)



Step	Action	WIRING DIAGRAM	
		Control signal	Location (Electrical components)
1	Initial check items	—	—
2	PS9 I/O check, sensor check	DFCB PJ14-8 (ON)	DF-611 C-5
3	PS8 I/O check, sensor check	DFCB PJ12-2 (ON)	DF-611 I-3
4	M5 operation check	REYB PJ3-7 to 8	DF-611 K to L-9
5	DFCB replacement	—	—

### 8.4.2 Paper feed section misfeed

#### A. Detection timing

Type	Description
Detection of misfeed at paper feed section	The after separate sensor (PS4) is not turned ON after a lapse of a given time after the take-up motor (M2) is turned ON.

#### B. Action

Relevant electrical parts	
Take-up motor (M2) After separate sensor (PS4)	DF control board (DFCB)



Step	Action	WIRING DIAGRAM	
		Control signal	Location (Electrical components)
1	Initial check items	—	—
2	PS4 I/O check, sensor check	DFCB PJ11-6 (ON)	DF-611 C-4 to 5
3	M2 operation check	DFCB PJ8-5 to 10	DF-611 I-6
4	DFCB replacement	—	—





### 8.4.3 Transport section misfeed

#### A. Detection timing

Type	Description
Detection of misfeed at transport section	The registration sensor (PS3) is not turned ON after a lapse of a given time after the after separate sensor (PS4) is turned ON.
	The before read sensor (PS9) is not turned ON after a lapse of a given time after the registration sensor (PS3) is turned ON.
Detection of paper left in transport section	The after separate sensor (PS4) is not turn OFF after a lapse of a given time after the after separate sensor (PS4) is turned ON.
	The registration sensor (PS3) is not turned OFF after a lapse of given time after the after separate sensor (PS4) is turned OFF.

#### B. Action

Relevant electrical parts	
Take-up motor (M2) Registration sensor (PS3) After separate sensor (PS4) Before read sensor (PS9)	DF control board (DFCB)



Step	Action	WIRING DIAGRAM	
		Control signal	Location (Electrical components)
1	Initial check items	—	—
2	Adjust the height of the guide support for the original glass moving unit. <a href="#">See P.456 of the main body service manual.</a>	—	—
3	PS3 I/O check, sensor check	DFCB PJ10-11 (ON)	DF-611 C-3
4	PS4 I/O check, sensor check	DFCB PJ11-6 (ON)	DF-611 C-4 to 5
5	PS9 I/O check, sensor check	DFCB PJ14-8 (ON)	DF-611 C-5 to 6
6	M2 operation check	DFCB PJ8-5 to 10	DF-611 I-6
7	DFCB replacement	—	—

### 8.4.4 Paper exit section misfeed

#### A. Detection timing

Type	Description
Detection of misfeed at paper exit section	The exit sensor (PS5) is not turned ON after a lapse of a given time after the before read sensor (PS9) is turned ON.
	<ul style="list-style-type: none"> <li>The exit sensor (PS5) is not turned ON after a lapse of a given time after the before read sensor (PS9) is turned OFF.</li> <li>The exit sensor (PS5) is not turned OFF after a lapse of a given time after the turnover and paper exit motion is performed.</li> </ul>
Detection of paper left in paper exit section	The exit sensor (PS5) is not turned OFF after a lapse of a given time after the before read sensor (PS9) is turned OFF.

#### B. Action

Relevant electrical parts	
Exit motor (M3) Before read sensor (PS9) Exit sensor (PS5)	DF control board (DFCB)



Step	Action	WIRING DIAGRAM	
		Control signal	Location (Electrical components)
1	Initial check items	—	—
2	PS9 I/O check, sensor check	DFCB PJ14-8 (ON)	DF-611 C-5 to 6
3	PS5 I/O check, sensor check	DFCB PJ3-3 (ON)	DF-611 I-6
4	M3 operation check	DFCB PJ8-1 to 4	DF-611 I-6
5	DFCB replacement	—	—

### 8.4.5 Image reading section misfeed

#### A. Detection timing

Type	Description
Detection of paper left in image reading section	The before read sensor (PS9) is not turned OFF after a lapse of a given time after the registration sensor (PS3) is turned OFF.
	The before read sensor (PS9) is not turned OFF after a lapse of a given time after the reverse registration sensor (PS8) is turned OFF.

#### B. Action

Relevant electrical parts	
Reading motor (M1) Reading roller pressure/retraction motor (M4) Registration sensor (PS3) Reverse registration sensor (PS8) Before read sensor (PS9)	DF control board (DFCB)



Step	Action	WIRING DIAGRAM	
		Control signal	Location (Electrical components)
1	Initial check items	—	—
2	Make the adjustment of original stop position. <a href="#">See P.36</a>	—	—
3	PS3 I/O check, sensor check	DFCB PJ10-11 (ON)	DF-611 C-3
4	PS8 I/O check, sensor check	DFCB PJ12-2 (ON)	DF-611 I-3
5	PS9 I/O check, sensor check	DFCB PJ14-8 (ON)	DF-611 C-5 to 6
6	M1 operation check	DFCB PJ9-1 to 3	DF-611 I-7
7	M4 operation check	DFCB PJ6-4 to 5	DF-611 I-4 to 5
8	DFCB replacement	—	—

### 8.4.6 Original feeding interval misfeed

#### A. Detection timing

Type	Description
Original feeding interval misfeed	The before read sensor (PS9) is turned ON earlier than a given time after the before read sensor (PS9) is turned OFF during original transportation.

Relevant electrical parts	
Take-up motor (M2) Before read sensor (PS9)	DF control board (DFCB)



Step	Action	WIRING DIAGRAM	
		Control signal	Location (Electrical components)
1	Initial check items	—	—
2	PS9 I/O check, sensor check	DFCB PJ14-8 (ON)	DF-611 C-5 to 6
3	M4 operation check	DFCB PJ8-5 to 10	DF-611 I-6
4	DFCB replacement	—	—

### 8.4.7 Remaining paper misfeed

#### A. Detection timing

Type	Description
Remaining paper misfeed	Due to a remaining sheet of paper that has not been detected by sensors, before the start of a job, a sensor detects the sheet at an unexpected timing.

#### B. Action

Relevant electrical parts	
Registration sensor (PS3) After separate sensor (PS4) Exit sensor (PS5) Reverse registration sensor (PS8) Before read sensor (PS9)	DF control board (DFCB)



Step	Action	WIRING DIAGRAM	
		Control signal	Location (Electrical components)
1	Remove the remaining paper.	—	—
2	Initial check items	—	—
3	PS3 I/O check, sensor check	DFCB PJ10-11 (ON)	DF-611 C-3
4	PS4 I/O check, sensor check	DFCB PJ11-6 (ON)	DF-611 C-4 to 5
5	PS5 I/O check, sensor check	DFCB PJ3-3 (ON)	DF-611 I-6
6	PS8 I/O check, sensor check	DFCB PJ12-2 (ON)	DF-611 I-3
7	PS9 I/O check, sensor check	DFCB PJ14-8 (ON)	DF-611 C-5 to 6
8	DFCB replacement	—	—



## 9. Trouble code

### 9.1 Trouble code list

- The main unit's cpu performs a self-diagnostics function that, on detecting a malfunction, gives the corresponding malfunction code on the touch panel.

Code	Description	Detection timing	Rank
C8101	Pressure/retraction mechanism failure before image reading	<ul style="list-style-type: none"> <li>During a pressure motion being performed, the read roller sensor (PS6) output does not change from H to L.</li> <li>During a retraction motion being performed, the read roller sensor (PS6) output does not change from L to H.</li> </ul>	B
C8102	Pressure/retraction mechanism failure at the turnover section	<ul style="list-style-type: none"> <li>During a pressure motion being performed, the reverse roller sensor (PS7) output does not change from H to L.</li> <li>During a retraction motion being performed, the reverse roller sensor (PS7) output does not change from L to H.</li> </ul>	B
C8103	Lift up mechanism failure	<ul style="list-style-type: none"> <li>The lift up upper sensor (PS16) is not turned ON after a lapse of a given time after the lift-up motor (M6) moves up (is turned forward).</li> <li>The lift up lower sensor (PS15) is not turned ON after a lapse of a given time after the lift-up motor (M6) goes down (is turned backward).</li> </ul>	B
C8104	Original glass travel failure	<ul style="list-style-type: none"> <li>The glass home sensor (PS203) output does not change from H to L after a lapse of a given time while the original glass moving motor (M202) is working.</li> <li>The glass home sensor (PS203) output does not change from L to H after a lapse of a given time while the original glass moving motor (M202) is working.</li> </ul>	B
C8302	Cooling fan failure	<ul style="list-style-type: none"> <li>The lock signal continues to detect H during a given time while the cooling fan (FM1) is spinning</li> <li>The lock signal continues to detect L during a given time while the cooling fan (FM1) is during halts.</li> </ul>	B
CC156	ADF ROM malfunction	<ul style="list-style-type: none"> <li>Upgrade of the firmware has not been successful.</li> </ul>	B
CC165	Incorrect ROM content	<ul style="list-style-type: none"> <li>When the power is turned ON, DF control board or firmware error is detected.</li> </ul>	B

## 9.2 Solution

### 9.2.1 C8101: Pressure/retraction mechanism failure before image reading

Relevant electrical parts	
Reading roller pressure/retraction motor (M4) Read roller sensor (PS6)	DF control board (DFCB)



Step	Action	WIRING DIAGRAM	
		Control signal	Location (Electrical components)
1	Check the motor and sensor connectors for proper connection, and correct as necessary.	—	—
2	Check the connector of M4 for proper drive coupling, and correct as necessary.	—	—
3	M4 operation check	DFCB PJ6-4 to 5	DF-611 I-4 to 5
4	PS6 I/O check, sensor check	DFCB PJ6-3 (ON)	DF-611 I-5
5	DFCB replacement	—	—

### 9.2.2 C8102: Pressure/retraction mechanism failure at the turnover section

Relevant electrical parts	
Switchback roller pressure/retraction motor (M5) Reverse roller sensor (PS7)	DF control board (DFCB)



Step	Action	WIRING DIAGRAM	
		Control signal	Location (Electrical components)
1	Check the motor and sensor connectors for proper connection, and correct as necessary.	—	—
2	Check the connector of M5 for proper drive coupling, and correct as necessary.	—	—
3	M5 operation check	REYB PJ3-7 to 8	DF-611 K to L-9
4	PS7 I/O check, sensor check	REYB PJ3-3 (ON)	DF-611 K to L-10
5	DFCB replacement	—	—



**9.2.3 C8103: Lift up mechanism failure**

Relevant electrical parts	
Lift-up motor (M6) Lift up lower sensor (PS16) Lift up upper sensor (PS15)	DF control board (DFCB)



Step	Action	WIRING DIAGRAM	
		Control signal	Location (Electrical components)
1	Check the motor and sensor connectors for proper connection, and correct as necessary.	—	—
2	Check the connector of M6 for proper drive coupling, and correct as necessary.	—	—
3	M6 operation check	REYB PJ6-1 to 2	DF-611 K to L-11
4	PS16 I/O check, sensor check	DFCB PJ11-3 (ON)	DF-611 C-5
5	PS15 I/O check, sensor check	REYB PJ3-6 (ON)	DF-611 K to L-10
6	DFCB replacement	—	—

**9.2.4 C8104: Original glass travel failure**

Relevant electrical parts	
Original glass moving unit Original glass moving motor (M202)	Original glass position control board (OGPCB)

Step	Action	WIRING DIAGRAM	
		Control signal	Location (Electrical components)
1	Check the motor and sensor connectors for proper connection, and correct as necessary.	—	—
2	Check the connector of M202 for proper drive coupling, and correct as necessary.	—	—
3	Original glass moving unit replacement	—	—
4	OGPCB replacement	—	—

**9.2.5 C8302: Cooling fan failure**

Relevant electrical parts	
Cooling fan (FM1)	DF control board (DFCB)



Step	Action	WIRING DIAGRAM	
		Control signal	Location (Electrical components)
1	Check the connector of FM1 for proper connection and correct as necessary.	—	—
2	Check the fan for possible overload and correct as necessary.	—	—
3	FM1 operation check	DFCB PJ7-1 (ON) DFCB PJ7-3 (LOCK)	DF-611 I-7
4	DFCB replacement	—	—

**9.2.6 CC156: ADF ROM malfunction**

Relevant electrical parts	
DF control board (DFCB)	

Step	Action	WIRING DIAGRAM	
		Control signal	Location (Electrical components)
1	Disconnect and then connect the power cord. Turn OFF the main power switch, wait for 10 sec. or more, and turn ON the main power switch.	—	—
2	Rewrite firmware using the compact flash card.	—	—
3	DFCB replacement	—	—

**9.2.7 Incorrect ROM content**

Relevant electrical parts	
DF control board (DFCB)	

Step	Action	WIRING DIAGRAM	
		Control signal	Location (Electrical components)
1	Rewrite firmware using the compact flash card.	—	—
2	DFCB replacement	—	—



## 10. Set error detection

- When the ADF or cover set error for some reason is detected, the panel of the main unit will have the following display.

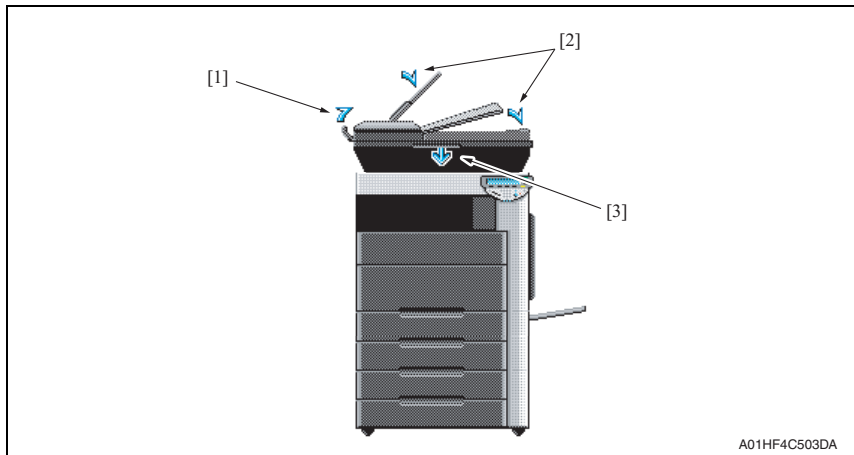

A01HF4C503DA

<Panel display and detection timing for each>

Panel display	Description of error	Detection start	Detection timing
[1]	Transportation cover set error	When the main power switch turn ON.	Read open & close sensor (when light-blocked)
[2]	Document feed tray set error	When the main power switch turn ON.	Feed open & close sensor (when light-blocked)
[3]	ADF set error	When the document is set in the ADF	Original cover sensor (ON)



KONICA MINOLTA

**SERVICE MANUAL**

FIELD SERVICE

---

# PC-104/204





# Revision history

After publication of this service manual, the parts and mechanism may be subject to change for improvement of their performance.

Therefore, the descriptions given in this service manual may not coincide with the actual machine.

When any change has been made to the descriptions in the service manual, a revised version will be issued with a revision mark added as required.

Revision mark:

- To indicate clearly a specific section revised within text,  is shown at the left margin of the corresponding revised section.  
The number inside  represents the number of times the revision has been made.
- To indicate clearly a specific page that contains a revision or revisions, the page number appearing at the left or right bottom of the specific page is marked with .  
The number inside  represents the number of times the revision has been made.

## NOTE

Revision marks shown in a page are restricted only to the latest ones with the old ones deleted.

- When a page revised in Ver. 2.0 has been changed in Ver. 3.0:  
The revision marks for Ver. 3.0 only are shown with those for Ver. 2.0 deleted.
- When a page revised in Ver. 2.0 has not been changed in Ver. 3.0:  
The revision marks for Ver. 2.0 are left as they are.

2008/01	2.0		Error correction
2007/07	1.0	—	Issue of the first edition
Date	Service manual Ver.	Revision mark	Descriptions of revision

# CONTENTS

## PC-104/204

### General

1. Product specifications ..... 1

### Maintenance

2. Periodical check ..... 3

2.1 Maintenance procedure (Periodical check parts) ..... 3

2.1.1 Replacing the separation roller assy ..... 3

2.1.2 Replacing the feed roller ..... 5

2.1.3 Replacing the pick-up roller..... 8

3. Other ..... 11

3.1 Disassembly/Adjustment prohibited items ..... 11

3.2 Disassembly/Assembly/Cleaning list (Other parts) ..... 12

3.2.1 Disassembly/Assembly parts list..... 12

3.2.2 Cleaning parts list ..... 12

3.3 Disassembly/Assembly procedure..... 13

3.3.1 Right door/Rear right cover/Lower right cover/Front right cover..... 13

3.3.2 Rear cover/Left cover ..... 13

3.4 Cleaning procedure ..... 14

3.4.1 Separation roller..... 14

3.4.2 Feed roller ..... 15

3.4.3 Pick-up roller ..... 15

3.4.4 Vertical transport roller ..... 16

### Adjustment/Setting

4. How to use the adjustment section ..... 17

5. Sensor check..... 18

5.1 Check procedure ..... 18

5.1.1 Sensor check screen..... 18

5.1.2 Sensor check list ..... 19

6. Mechanical adjustment ..... 20

6.1 Adjusting the paper reference position ..... 20

6.1.1 Centering ..... 20

6.1.2 Centering (Duplex 2nd Side)..... 22

PC-104/204

General

Maintenance

Adjustment / Setting

Troubleshooting

# Troubleshooting

7.	Jam display .....	23
7.1	Misfeed display .....	23
7.1.1	Misfeed display resetting procedure .....	23
7.2	Sensor layout .....	24
7.3	Solution .....	25
7.3.1	Initial check items .....	25
7.3.2	Tray3 feed section/vertical transport section misfeed (PC-104/204).....	26
7.3.3	Tray4 feed section/vertical transport section misfeed (PC-204).....	27
8.	Trouble code .....	28
8.1	Trouble code display .....	28
8.2	Trouble code list.....	28
8.3	Solution .....	29
8.3.1	C0206: Tray3 lift-up failure	
	C0208: Tray4 lift-up failure .....	29

# General

## 1. Product specifications

### A. Type

Name	2 way paper feed cabinet
Type	Front loading type 2 way paper feed device
Installation	Desk type
Document alignment	Center

### B. Paper

Type	Size	Capacity	
		Tray 3	Tray 4
Plain paper (60 to 90 g/m <sup>2</sup> (16 to 24 lb))	A5S to A3, 5-1/2 x 8-1/2S to 11 x 17	500 sheets	500 sheets
Thick paper 1 (91 to 150 g/m <sup>2</sup> (24.25 to 40 lb))		150 sheets	150 sheets
Thick paper 2 (151 to 209 g/m <sup>2</sup> (40 to 55.5 lb))			
Thick paper 3 (210 to 256 g/m <sup>2</sup> (55.75 to 68 lb))			

### C. Machine specifications

Power requirements	DC 24 V $\pm$ 10 % (supplied from the main body)
	DC 5 V $\pm$ 5 %
Max. power consumption	15 W or less
Dimensions	600 mm (W) x 578 mm (D) x 301 mm (H) 23.5 inch (W) x 22.75 inch (D) x 11.75 inch (H)
Weight	PC-104: 24.0 kg (53 lb)
	PC-204: 28.0 kg (61.75 lb)

### D. Operating environment

Conforms to the operating environment of the main body.

#### NOTE

- These specifications are subject to change without notice.

Blank Page

# Maintenance

## 2. Periodical check

### 2.1 Maintenance procedure (Periodical check parts)

#### 2.1.1 Replacing the separation roller assy

##### A. Periodically replaced parts/cycle

- Separation roller assy: Every 300,000 prints

##### NOTE

- Replace the separation roller assy, feed roller and pick-up roller at the same time.

##### B. Replacing procedure

1. Remove the right door.

See P.13

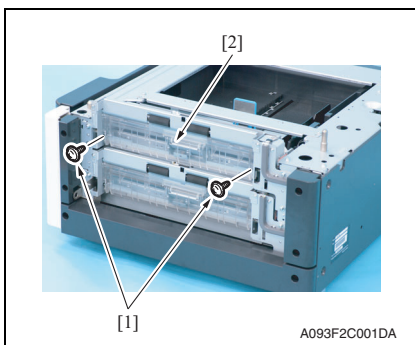

2. Remove two screws [1] and remove the jam access cover [2].

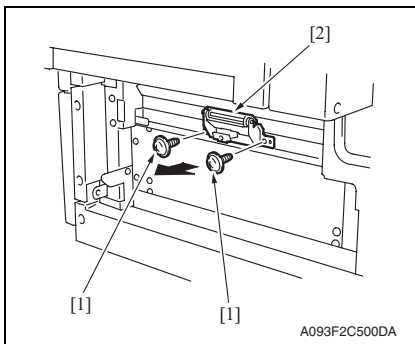

3. Remove two screws [1] and remove the paper separation roller mounting bracket assy [2].



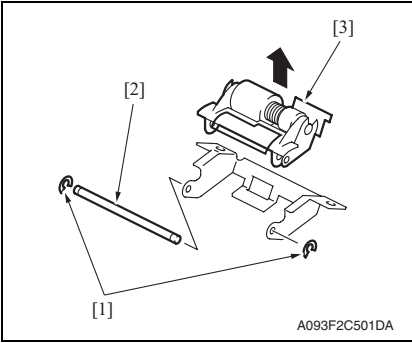

- Remove two C-rings [1] and the shaft [2], and remove the paper separation roller fixing bracket assy [3].

**NOTE**

- Be careful not to lose spring at this time.

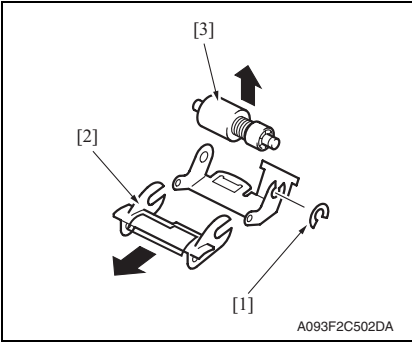

- Remove the C-ring [1], the guide [2], and remove the separation roller assy [3].

- Repeat steps 1 to 5 similarly for the 4th drawer.

**NOTE**

- Install the separation roller assy while pressing the holder down so that it aligns to the metal bracket of the machine.
- Make sure that the separation roller assy is not tilted to the right or left when installed.

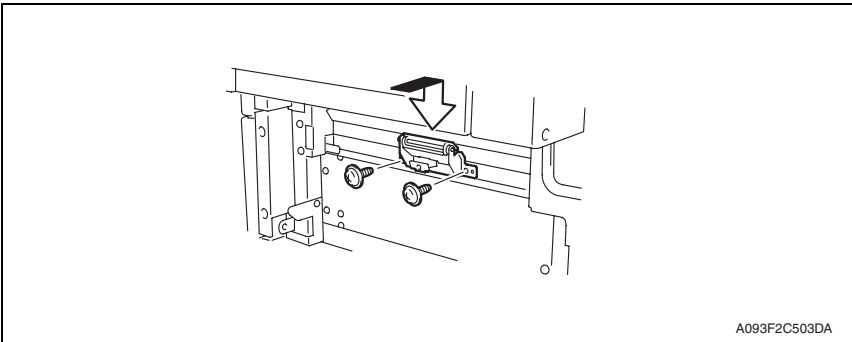

## 2.1.2 Replacing the feed roller

### A. Periodically replaced parts/cycle

- Feed roller: Every 300,000 prints

### NOTE

- **Replace the separation roller assy, feed roller and pick-up roller at the same time.**

### B. Replacing procedure

1. Remove the rear right cover. (Remove the right lower cover for 4th row.)  
[See P.13](#)
2. Remove the tray3. (Remove the tray4 from 4th row.)
3. Remove the paper separation roller mounting bracket assy.  
[See the procedures 1 to 3 in P.3 "Replacing the separation roller assy."](#)

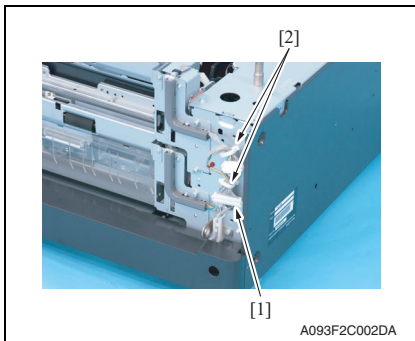

4. Disconnect the connector [1] and remove the harness from two wire saddles [2].

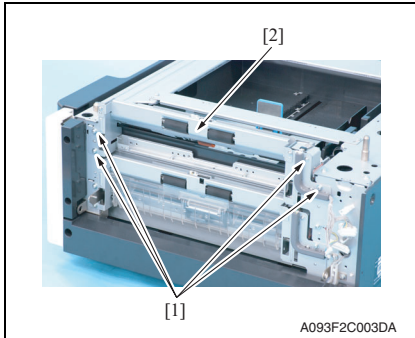

5. Remove four screws [1] and remove the feed unit [2].

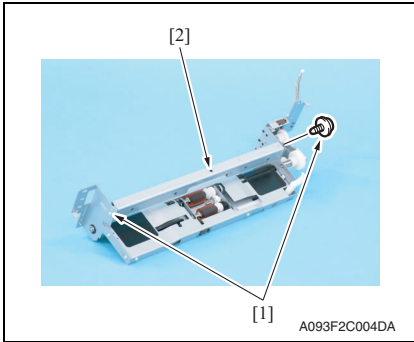

- 6. Remove two screws [1] and remove the mounting frame [2] for the paper separation roller mounting bracket assy.

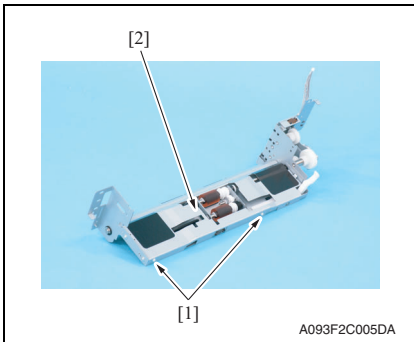

- 7. Remove two screws [1] and remove the feed roller cover [2].

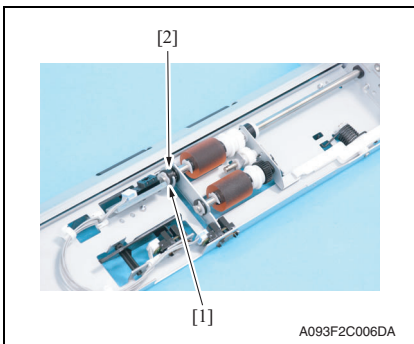

- 8. Remove the C-ring [1] and remove the bushing [2].

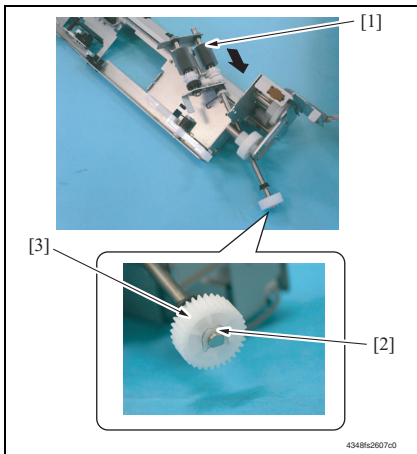

9. Shift the shaft assy [1] in the orientation as shown on the left, and remove the C-ring [2] and the gear [3].

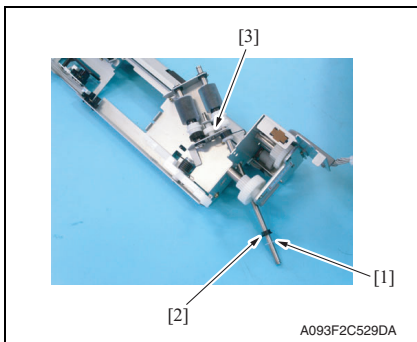

10. Remove the C-ring [1], the bushing [2], and remove the shaft assy [3].

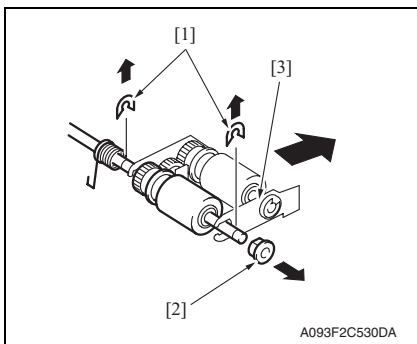

11. Remove two E-rings [1] and the bushing [2], and remove the pick-up roller fixing bracket assy [3].

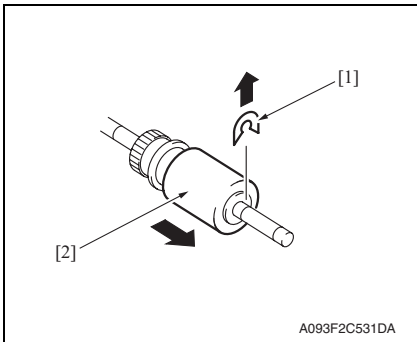

12. Remove the C-ring [1] and remove the feed roller [2].

13. Repeat steps 1 to 12 similarly for the 4th drawer.

### 2.1.3 Replacing the pick-up roller

#### A. Periodically replaced parts/cycle

- Pick-up roller: Every 300,000 prints

#### NOTE

- **Replace the separation roller assy, feed roller and pick-up roller at the same time.**

#### B. Replacing procedure

1. Remove the rear right cover. (Remove the right lower cover for 4th row.)

[See P.13](#)

2. Remove the tray3. (Remove the tray4 from 4th row.)

3. Remove the separation roller mounting bracket assy.

[See the procedures 1 to 3 in P.3 "Replacing the separation roller assy."](#)

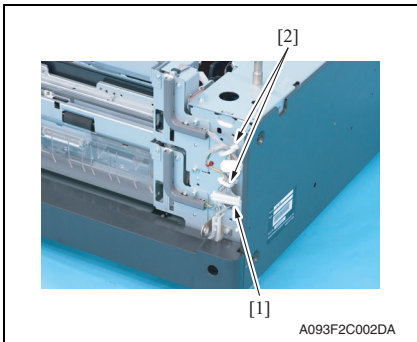

4. Disconnect the connector [1] and remove the harness from two wire saddles [2].

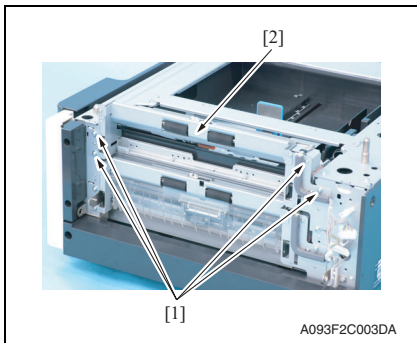

5. Remove four screws [1] and remove the feed unit [2].

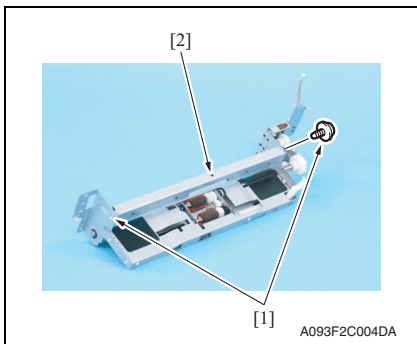

6. Remove two screws [1] and remove the mounting frame [2] for the paper separation roller mounting bracket assy.

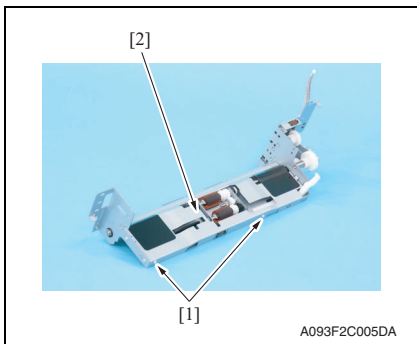

7. Remove two screws [1] and remove the feed roller cover [2].

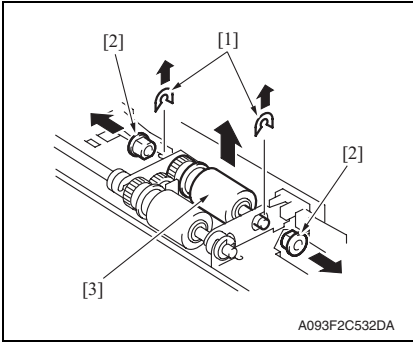

- 8. Remove two C-rings [1], two bushings [2], and remove the pick-up roller assy [3].

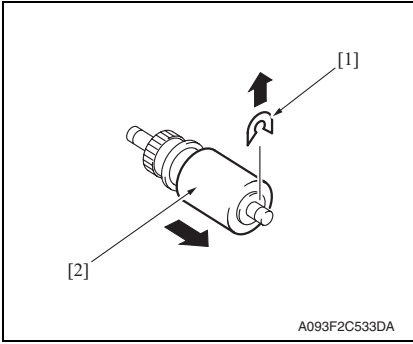

- 9. Remove the C-ring [1] and remove the pick-up roller [2].

10. Repeat steps 1 to 9 similarly for the 4th drawer.

## 3. Other

### 3.1 Disassembly/Adjustment prohibited items

#### A. Paint-locked screws

##### NOTE

- To prevent loose screws, a screw lock in blue or green series color is applied to the screws.
- The screw lock is applied to the screws that may get loose due to the vibrations and loads created by the use of machine or due to the vibrations created during transportation.
- If the screw lock coated screws are loosened or removed, be sure to apply a screw lock after the screws are tightened.

#### B. Red-painted screws

##### NOTE

- The screws which are difficult to be adjusted in the field are painted in red in order to prevent them from being removed by mistake.
- Do not remove or loosen any of the red-painted screws in the field. It should also be noted that, when two or more screws are used for a single part, only one representative screw may be marked with the red paint.

#### C. Variable resistors on board

##### NOTE

- Do not turn the variable resistors on boards for which no adjusting instructions are given in Adjustment/Setting.

#### D. Removal of PWBs

##### CAUTION

- When removing a circuit board or other electrical component, refer to “Handling of PWBs” and follow the corresponding removal procedures.
- The removal procedures given in the following omit the removal of connectors and screws securing the circuit board support or circuit board.
- Where it is absolutely necessary to touch the ICs and other electrical components on the board, be sure to ground your body.



### 3.2 Disassembly/Assembly/Cleaning list (Other parts)

#### 3.2.1 Disassembly/Assembly parts list

No.	Section	Part name	Ref. page
1	Exterior parts	Right door	<a href="#">P.13</a>
2		Rear right cover	<a href="#">P.13</a>
3		Lower right cover	<a href="#">P.13</a>
4		Front right cover	<a href="#">P.13</a>
5		Rear cover	<a href="#">P.13</a>
6		Left cover	<a href="#">P.13</a>

#### 3.2.2 Cleaning parts list

No.	Section	Part name	Ref. page
1	Feed section	Separation roller	<a href="#">P.14</a>
2		Feed roller	<a href="#">P.15</a>
3		Pick-up roller	<a href="#">P.15</a>
4	Transport section	Vertical transport roller	<a href="#">P.16</a>

### 3.3 Disassembly/Assembly procedure

#### 3.3.1 Right door/Rear right cover/Lower right cover/Front right cover

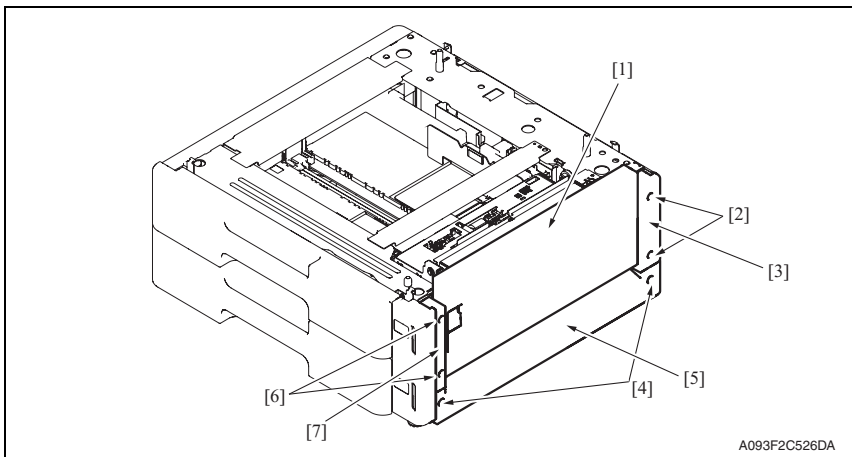

1. Open the right door [1].
2. Remove the right door [1].
3. Remove two screws [2] and remove the rear right cover [3].
4. Remove two screws [4] and remove the lower right cover [5].
5. Remove two screws [6] and remove the front right cover [7].

#### 3.3.2 Rear cover/Left cover

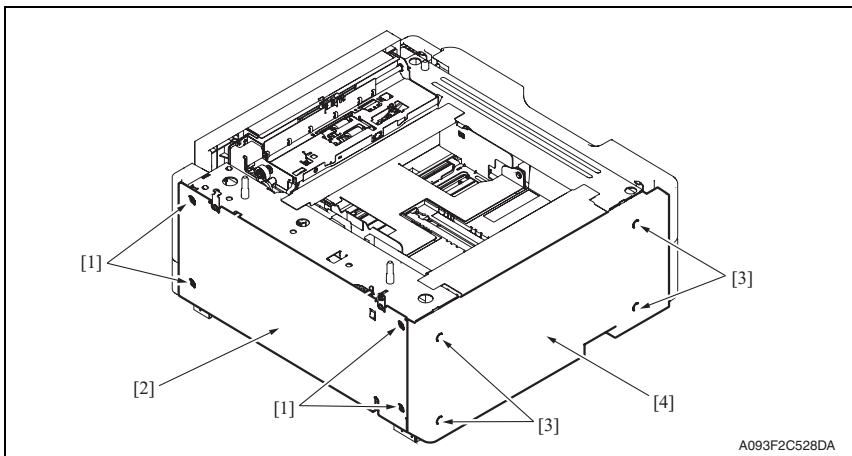

1. Remove four screws [1] and remove the rear cover [2].
2. Remove four screws [3] and remove the left cover [4].

### 3.4 Cleaning procedure

#### NOTE

- The alcohol described in the cleaning procedure represents the isopropyl alcohol.

#### 3.4.1 Separation roller

1. Remove the right door.

See P.13

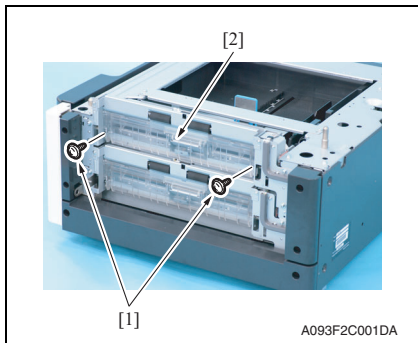

2. Remove two screws [1] and remove the jam access cover [2].

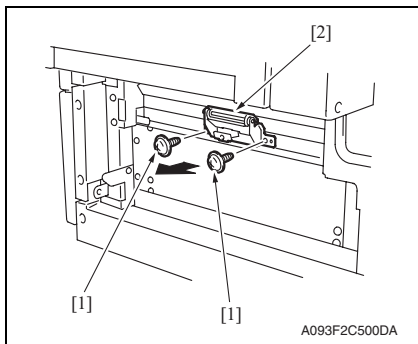

3. Remove two screws [1] and remove the separation roller mounting bracket assy [2].

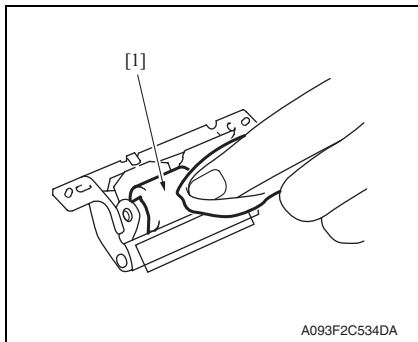

4. Using a cleaning pad dampened with alcohol, wipe the separation roller [1] clean of dirt.

5. Repeat steps 1 to 4 similarly for the 4th drawer.

### 3.4.2 Feed roller

1. Remove the tray3. (remove the tray4 from 4th row.)
2. Remove the separation roller mounting bracket assy.  
[See the procedures 1 to 3 in P.14 "Cleaning of the separation roller."](#)

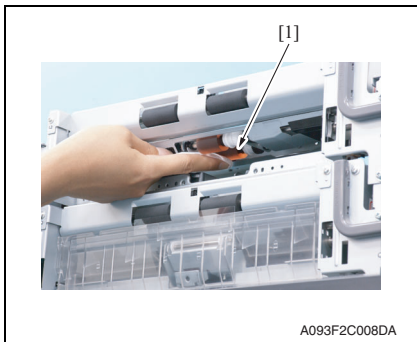

3. Using a cleaning pad dampened with alcohol, wipe the feed roller [1] clean of dirt.

4. Repeat steps 1 to 3 similarly for the 4th drawer.

### 3.4.3 Pick-up roller

1. Remove the tray3. (remove the tray4 from 4th row.)
2. Remove the separation roller mounting bracket assy.  
[See the procedures 1 to 3 in P.14 "Cleaning of the separation roller."](#)

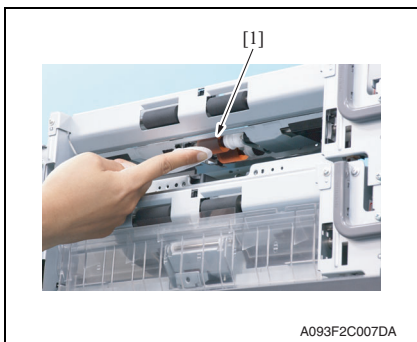

3. Using a cleaning pad dampened with alcohol, wipe the pick-up roller [1] clean of dirt.

4. Repeat steps 1 to 3 similarly for the 4th drawer.

### 3.4.4 Vertical transport roller

1. Open the right door.

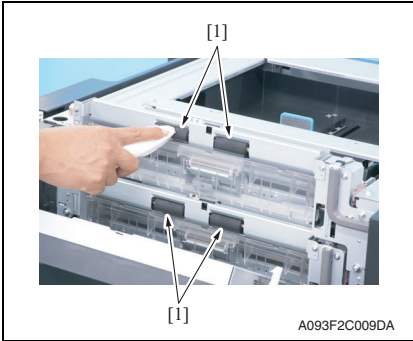

2. Using a cleaning pad dampened with alcohol, wipe the vertical transport roller [1] clean of dirt.

## Adjustment/Setting

### 4. How to use the adjustment section

- “Adjustment/Setting” contains detailed information on the adjustment items and procedures for this machine.
- Throughout this “Adjustment/Setting,” the default settings are indicated by “ ”.

#### Advance checks

Before attempting to solve the customer problem, the following advance checks must be made. Check to see if:

- The power supply voltage meets the specifications.
- The power supply is properly grounded.
- The machine shares the power supply with any other machine that draws large current intermittently (e.g., elevator and air conditioner that generate electric noise).
- The installation site is environmentally appropriate: high temperature, high humidity, direct sunlight, ventilation, etc.; levelness of the installation site.
- The original has a problem that may cause a defective image.
- The density is properly selected.
- The original glass, slit glass, or related part is dirty.
- Correct paper is being used for printing.
- The units, parts, and supplies used for printing (developer, PC drum, etc.) are properly replenished and replaced when they reach the end of their useful service life.
- Toner is not running out.

#### CAUTION

- **Be sure to unplug the power cord of the machine before starting the service job procedures.**
- **If it is unavoidably necessary to service the machine with its power turned ON, use utmost care not to be caught in the scanner cables or gears of the exposure unit.**
- **Special care should be used when handling the fusing unit which can be extremely hot.**
- **The developing unit has a strong magnetic field. Keep watches and measuring instruments away from it.**
- **Take care not to damage the PC drum with a tool or similar device.**
- **Do not touch IC pins with bare hands.**

# 5. Sensor check

## 5.1 Check procedure

### A. Procedure

1. Call the Service Mode to the screen.  
[See P.338 of the main body service manual.](#)
2. Touch [State Confirmation].
3. Touch [Sensor Check].

#### 5.1.1 Sensor check screen

- This is only typical screen which may be different from what are shown on each individual main body.

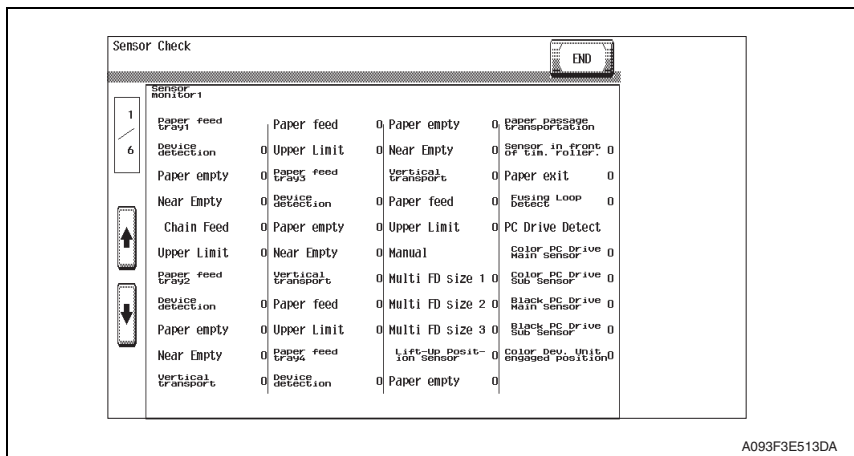

**5.1.2 Sensor check list**

**A. Sensor monitor1**

Symbol	Panel display		Part/Signal name	Operation characteristics/Panel display	
				1	0
PS112	Paper feed tray3	Device Detection	Tray3 device detection sensor	Set	Out of position
PS115		Paper Empty	Tray3 empty sensor	Paper not present	Paper present
PS113		Near Empty	Tray3 near empty sensor	Blocked	Unblocked
PS117		Vertical Transport	Tray3 vertical transport sensor	Paper present	Paper not present
PS116		Take-Up	Tray3 paper feed sensor	Paper present	Paper not present
PS114		Upper Limit	Tray3 upper limit sensor	Raised Position	Not raised
PS121	Paper feed tray4	Device Detection	Tray4 device detection sensor	Set	Out of position
PS124		Paper Empty	Tray4 empty sensor	Paper not present	Paper present
PS122		Near Empty	Tray4 near empty sensor	Blocked	Unblocked
PS126		Vertical Transport	Tray4 vertical transport sensor	Paper present	Paper not present
PS125		Take-Up	Tray4 paper feed sensor	Paper present	Paper not present
PS123		Upper Limit	Tray4 upper limit sensor	Raised Position	Not raised

PC-104/204

Adjustment / Setting



# 6. Mechanical adjustment

## 6.1 Adjusting the paper reference position

### NOTE

- Make this adjustment after any of the following procedures has been performed.
  - When the PH unit has been replaced.
  - When the image on the print is offset in the sub scan direction.
  - When a faint image occurs on the leading edge of the image.

### 6.1.1 Centering

1. Call the Service Mode to the screen.  
[See P.338 of the main body service manual.](#)
2. Touch [Machine] → [Printer Area].
3. Touch [Centering] → [3rd.].

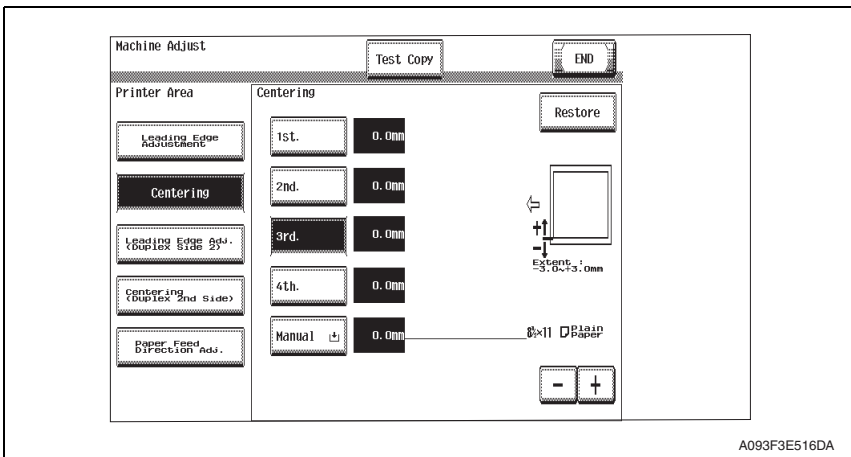

4. Press the Start key to let the machine produce a test print.

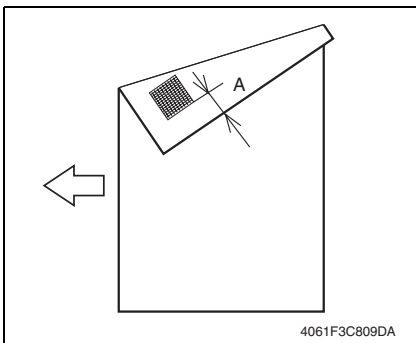

5. Measure the width of printed reference line A.  
Specification: 3.0 mm ± 1.0 mm
6. If the measured width A falls outside the specified range, enter the correction value using the [-] or [+] key.
7. Produce another test print and check to see if width A falls within the specified range.

### NOTE

- If the use of the [-] or [+] key does not allow the measurement to fall within the specified range, perform the following steps.

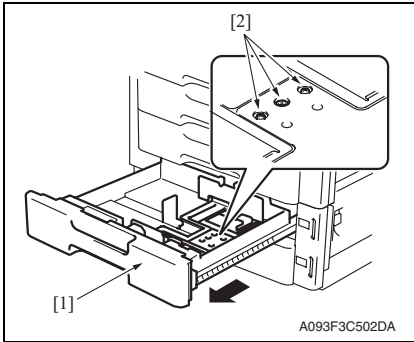

8. Slide out the drawer [1] and unload paper from it.
9. Loosen three screws [2] at the center of the paper lifting plate.

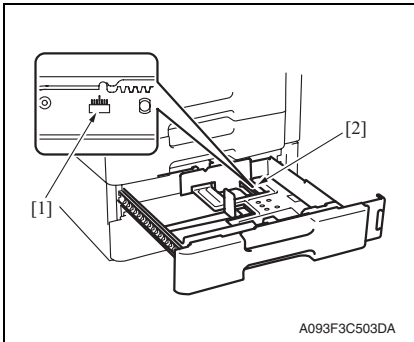

10. Watching the graduations [1] provided in the drawer, move the edge guide [2] in the rear.
  - If width A is greater than the specified value, move the edge guide toward the front.
  - If width A is smaller than the specified value, move the edge guide toward the rear.

11. Perform another test print and check the reference deviation.
12. Repeat the adjustment until the reference line falls within the specified range.
13. Tighten the adjustment screw.
14. Repeat steps 1 to 13 similarly for the tray 4.
15. Touch [END].
16. Touch [Exit] on the Service Mode screen.
17. Turn OFF the main power switch, then wait for 10 sec. or more and turn ON the main power switch.

### 6.1.2 Centering (Duplex 2nd Side)

1. Call the Service Mode to the screen.  
See P.338 of the main body service manual.
2. Touch [Machine] → [Printer Area].
3. Touch [Centering (Duplex 2nd Side)] → [3rd.].

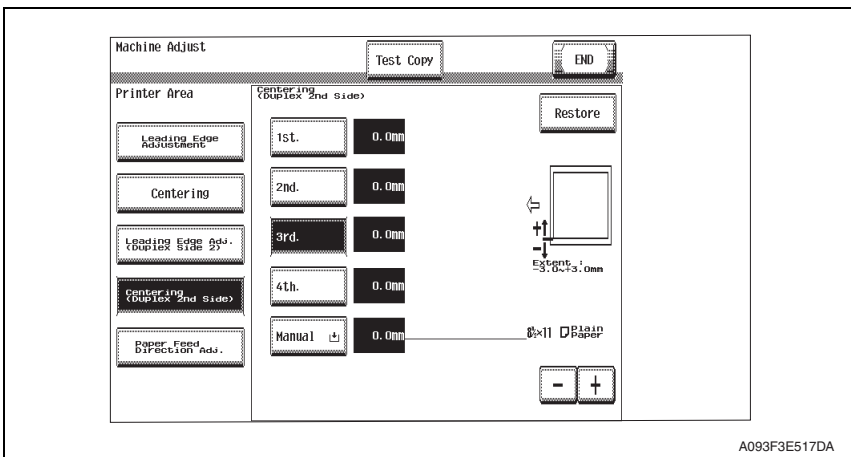

4. Press the Start key to let the machine produce a test pattern.

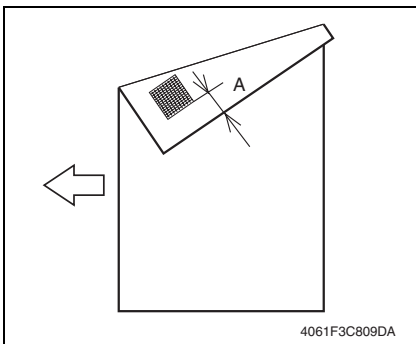

5. Measure the width of printed reference line A.  
Specification: 3.0 mm ± 2.0 mm
6. If the measured width A falls outside the specified range, enter the correction value using the [-] or [+] key.
7. Produce another test print and check to see if width A falls within the specified range.

8. Repeat steps 1 to 7 similarly for the tray 4.
9. Touch [END].
10. Touch [Exit] on the Service Mode screen.
11. Turn OFF the main power switch, then wait for 10 sec. or more and turn ON the main power switch.

# Troubleshooting

## 7. Jam display

### 7.1 Misfeed display

- When misfeed occurs, message, misfeed location “Blinking” and paper location “Lighting” are displayed on the touch panel of the main body.

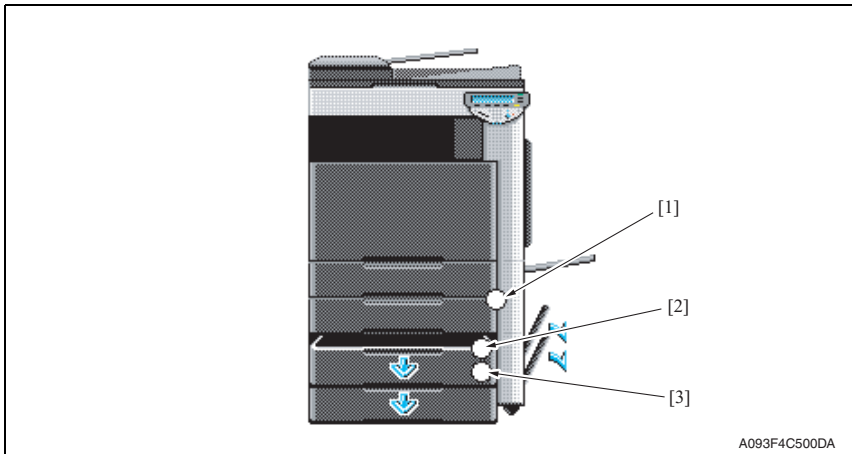

No.	Code	Misfeed location	Misfeed access location	Action
[2]	1301	Tray 3 feed section	Right door	P.26
[1]	2001	Tray 3 paper vertical transport section	Vertical transport door	
[3]	1401	Tray 4 feed section	Right door	P.27
[1]	2001	Tray 4 paper vertical transport section	Vertical transport door	

#### 7.1.1 Misfeed display resetting procedure

- Open the corresponding door, clear the sheet of paper misfed, and close the door.

### 7.2 Sensor layout

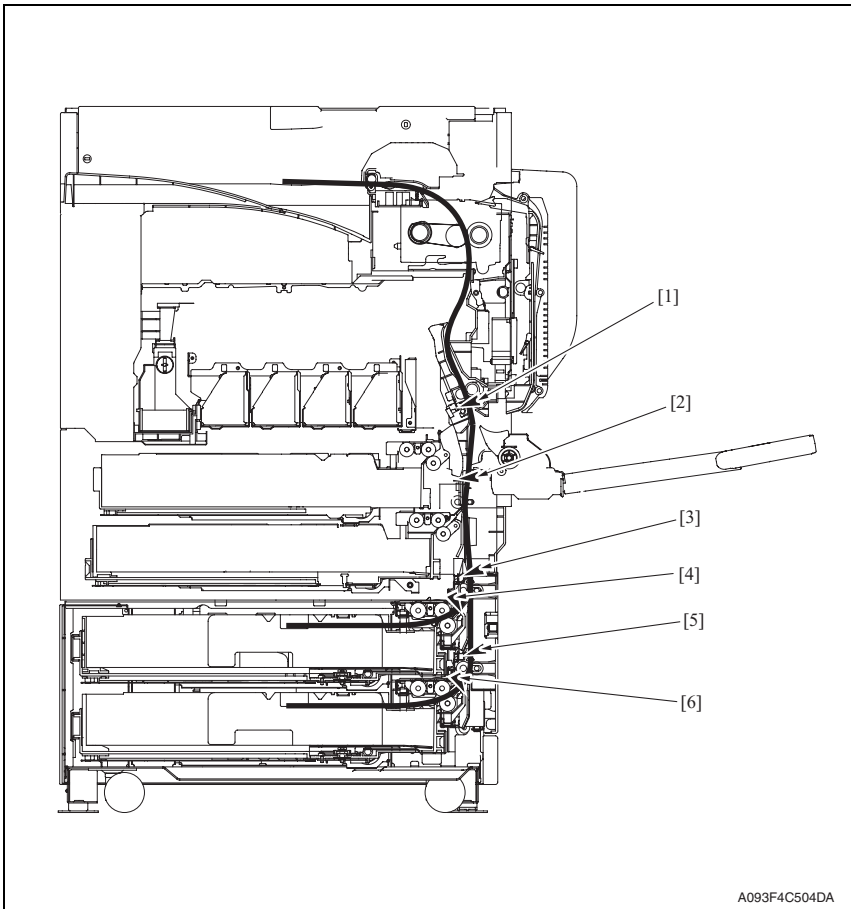

A093F4C504DA

- [1] Sensor in front of tim. roller (PS23)
- [2] Paper feed tray 2 vertical transport sensor (PS16)
- [3] Tray3 vertical transport sensor (PS117)
- [4] Tray3 paper feed sensor (PS116)
- [5] Tray4 vertical transport sensor (PS126)
- [6] Tray4 paper feed sensor (PS125)

PC-104/204

Troubleshooting

### 7.3 Solution

#### 7.3.1 Initial check items

- When a paper misfeed occurs, first perform the following initial check items.

Check item	Action
Does paper meet product specifications?	Replace paper.
Is the paper curled, wavy, or damp?	Replace paper. Instruct the user on the correct paper storage procedures.
Is a foreign object present along the paper path, or is the paper path deformed or worn?	Clean the paper path and replace if necessary.
Are rolls/rollers dirty, deformed, or worn?	Clean or replace the defective roll/roller.
Are the edge guide and trailing edge stop at the correct position to accommodate the paper?	Set as necessary.
Are the actuators operating correctly?	Correct or replace the defective actuator.

**7.3.2 Tray3 feed section/vertical transport section misfeed (PC-104/204)**

**A. Detection timing**

Type	Description
Tray3 feed section/vertical transport section misfeed detection	The leading edge of the paper does not block the tray3 vertical transport sensor (PS117) even after the set period of time has elapsed after the tray3 paper feed motor (M122) is energized.
	The paper feed tray 2 vertical transport sensor (PS16) is not blocked even after the lapse of a given period of time after the tray3 vertical transport sensor (PS117) has been blocked by a paper.
Tray 3 vertical transport section loop registration reversing jam	Rise timing of load for registration is earlier than the one for making the loop at front of the registration roller at tray 3 paper feed.
Tray3 detection of paper remaining	The tray3 vertical transport sensor (PS117) is blocked when the main power switch is set to ON, a door or cover is opened and closed, or a misfeed or malfunction is reset.
	The tray3 paper feed sensor (PS116) is blocked when the main power switch is set to ON, a door or cover is opened and closed, or a misfeed or malfunction is reset.
Misfeed detected as a result of delayed deactivation of sensor	The tray3 vertical transport sensor (PS117) is not unblocked even after the lapse of a given period of time after PS117 has been blocked by a paper.
Tray3 feed section image write start signal permit waiting jam	For paper fed from the tray3, image write start signal permit continues to be disabled for a predetermined period of time after the timing of image write start signal output.

**B. Action**

Relevant electrical parts	
Tray3 paper feed sensor (PS116) Tray3 vertical transport sensor (PS117) Paper feed tray 2 vertical transport sensor (PS16) Tray3 paper feed motor (M122) Sensor in front of tim. roller (PS23)	PC control board (PCCB)

Step	Action	WIRING DIAGRAM	
		Control signal	Location (Electrical components)
1	Initial check items	—	—
2	PS23 I/O check, sensor check	PRCB CN1-3 (ON)	bizhub C353/C253/C203 D-18
3	PS116 I/O check, sensor check	PCCB PJ6-8 (ON)	PC-104, PC-204 B-1 to 2
4	PS117 I/O check, sensor check	PCCB PJ6-11 (ON)	PC-104, PC-204 B-2
5	PS16 I/O check, sensor check	PCCB CN9-11 (ON)	bizhub C353/C253/C203 D-10
6	M122 operation check	PCCB PJ5-1 to 4	PC-104, PC-204 B-2 to 3
7	PCCB replacement	—	—

### 7.3.3 Tray4 feed section/vertical transport section misfeed (PC-204)

#### A. Detection timing

Type	Description
Tray4 feed section/ vertical transport section misfeed detection	The leading edge of the paper does not block the tray4 vertical transport sensor (PS126) even after the set period of time has elapsed after the tray4 paper feed motor (M123) is energized.
	The tray3 vertical transport sensor (PS117) is not blocked even after the lapse of a given period of time after the tray4 vertical transport sensor (PS126) has been blocked by a paper.
Tray 4 vertical transport section loop registration reversing jam	Rise timing of load for registration is earlier than the one for making the loop at front of the timing roller at tray 4 paper feed.
Tray4 detection of paper remaining	The tray4 vertical transport sensor (PS126) is blocked when the main power switch is set to ON, a door or cover is opened and closed, or a misfeed or malfunction is reset.
	The tray4 paper feed sensor (PS125) is blocked when the main power switch is set to ON, a door or cover is opened and closed, or a misfeed or malfunction is reset.
Misfeed detected as a result of delayed deactiva- tion of sensor	The tray4 vertical transport sensor (PS126) is not unblocked even after the lapse of a given period of time after PS126 has been blocked by a paper.
Tray4 feed section image write start signal permit wait- ing jam	For paper fed from the tray4, image write start signal permit continues to be disabled for a predetermined period of time after the timing of image write start signal output.



#### B. Action

Relevant electrical parts	
Tray4 paper feed sensor (PS125) Tray4 vertical transport sensor (PS126) Tray3 vertical transport sensor (PS117) Tray4 paper feed motor (M123) Sensor in front of tim. roller (PS23)	PC control board (PCCB)



Step	Action	WIRING DIAGRAM	
		Control signal	Location (Electrical components)
1	Initial check items	—	—
2	PS23 I/O check, sensor check	PRCB CN1-3 (ON)	bizhub C353/C253/ C203 D-18
3	PS125 I/O check, sensor check	PCCB PJ10-8 (ON)	PC-204 G-5
4	PS126 I/O check, sensor check	PCCB PJ11-2 (ON)	PC-204 G-5
5	PS117 I/O check, sensor check	PCCB PJ6-11 (ON)	PC-104, PC-204 B-2
6	M123 operation check	PCCB PJ9-1 to 4	PC-204 G-6
7	PCCB replacement	—	—





## 8. Trouble code

### 8.1 Trouble code display

- The main unit's CPU performs a self-diagnostics function that, on detecting a malfunction, gives the corresponding malfunction code on the touch panel.

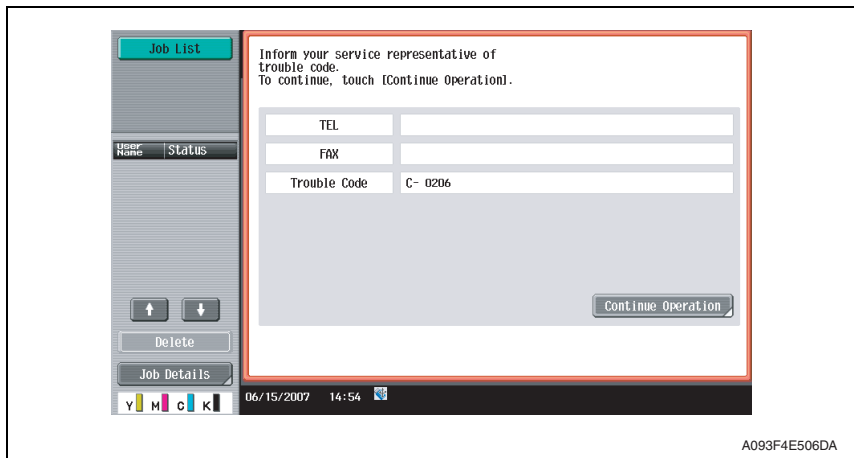

### 8.2 Trouble code list

Code	Item	Description
C0206	Tray3 lift-up failure	<ul style="list-style-type: none"> <li>The lift-up upper sensor is not blocked even after the set period of time has elapsed after the paper lift-up operation for the drawer began.</li> </ul>
C0208	Tray4 lift-up failure	

- Open and close the front door, or turn OFF the main power switch. Then, wait for 10 sec. or more and turn ON the main power switch to reset the malfunction display.

### 8.3 Solution

#### 8.3.1 C0206: Tray3 lift-up failure C0208: Tray4 lift-up failure

Relevant electrical parts	
Tray3 lift-up motor (M124)	PC control board (PCCB)
Tray4 lift-up motor (M125)	MFP board (MFPB)
Tray3 upper limit sensor (PS114)	DC power supply (DCPU)
Tray4 upper limit sensor (PS123)	



Step	Action	WIRING DIAGRAM	
		Control signal	Location (Electrical components)
1	Check the motor and sensor connectors for proper connection, and correct as necessary.	—	—
2	Check the connector of each motor for proper drive coupling, and correct as necessary.	—	—
3	Check the DCPU connector for proper connection, and correct as necessary.	—	—
4	PS114 I/O check, sensor check	PCCB PJ6-3 (ON)	PC-104, PC-204 B-1
5	PS123 I/O check, sensor check	PCCB PJ10-3 (ON)	PC-204 G-4
6	M124 operation check	PCCB PJ4-4 to 5	PC-104, PC-204 B-3 to 4
7	M125 operation check	PCCB PJ8-12 to 13	PC-204 G-1
8	PCCB replacement	—	—
9	MFPB replacement	—	—
10	DCPU replacement	—	—



Blank Page



KONICA MINOLTA

**SERVICE MANUAL**

**FIELD SERVICE**

---

# PC-405





# Revision history

After publication of this service manual, the parts and mechanism may be subject to change for improvement of their performance.

Therefore, the descriptions given in this service manual may not coincide with the actual machine.

When any change has been made to the descriptions in the service manual, a revised version will be issued with a revision mark added as required.



Revision mark:

- To indicate clearly a specific section revised within text,  is shown at the left margin of the corresponding revised section.  
The number inside  represents the number of times the revision has been made.
- To indicate clearly a specific page that contains a revision or revisions, the page number appearing at the left or right bottom of the specific page is marked with .  
The number inside  represents the number of times the revision has been made.

## NOTE

Revision marks shown in a page are restricted only to the latest ones with the old ones deleted.

- When a page revised in Ver. 2.0 has been changed in Ver. 3.0:  
The revision marks for Ver. 3.0 only are shown with those for Ver. 2.0 deleted.
- When a page revised in Ver. 2.0 has not been changed in Ver. 3.0:  
The revision marks for Ver. 2.0 are left as they are.

2008/01	3.0		Error correction
2007/11	2.0		Error correction
2007/07	1.0	—	Issue of the first edition
Date	Service manual Ver.	Revision mark	Descriptions of revision

# CONTENTS

## PC-405

### General

1. Product specification ..... 1

### Maintenance

2. Periodical check ..... 3

2.1 Maintenance procedure (Periodical check parts) ..... 3

2.1.1 Replacing the separation roller assy ..... 3

2.1.2 Replacing the feed roller ..... 5

2.1.3 Replacing the pick-up roller..... 8

3. Other ..... 10

3.1 Disassembly/adjustment prohibited items ..... 10

3.2 Disassembly/Assembly/Cleaning list (Other parts) ..... 11

3.2.1 Disassembly/Assembly parts list..... 11

3.2.2 Cleaning parts list ..... 11

3.3 Disassembly/Assembly procedure ..... 12

3.3.1 Right door/Rear right cover/Lower right cover/Front right cover..... 12

3.3.2 Rear cover/Left cover ..... 12

3.3.3 Drawer..... 13

3.3.4 Wire..... 14

3.4 Cleaning procedure ..... 18

3.4.1 Separation roller..... 18

3.4.2 Feed roller ..... 18

3.4.3 Pick-up roller ..... 19

3.4.4 Vertical transport roller ..... 20

### Adjustment/Setting

4. How to use the adjustment section ..... 21

5. Sensor check ..... 22

5.1 Check procedure ..... 22

5.1.1 Sensor check screen..... 22

5.1.2 Sensor check list ..... 23

6. Mechanical adjustment ..... 24

6.1 Adjusting the paper reference position ..... 24

6.1.1 Centering ..... 24

PC-405

General

Maintenance

Adjustment / Setting

Troubleshooting

6.1.2	Centering (Duplex 2nd Side) .....	26
6.2	Shifter movement timing belt adjustment .....	27

## Troubleshooting

7.	Jam display .....	29
7.1	Misfeed display .....	29
7.1.1	Misfeed display resetting procedure .....	29
7.2	Sensor layout .....	30
7.3	Solution .....	31
7.3.1	Initial check items .....	31
7.3.2	LCT paper feed section/vertical transport section misfeed .....	32
8.	Trouble code .....	33
8.1	Trouble code display .....	33
8.2	Trouble code list .....	34
8.3	Solution .....	36
8.3.1	C0001: LCT communication error .....	36
8.3.2	C0209: LCT elevator motor failure .....	36
8.3.3	C0210: LCT lift failure .....	37
8.3.4	C0212: LCT lock release failure .....	37
8.3.5	C0213: LCT shift gate operation failure .....	38
8.3.6	C0214: LCT shift failure .....	38
8.3.7	C0215: LCT shift motor failure .....	39

# General

## 1. Product specification

### A. Type

Name	Large capacity cabinet
Type	Front loading type LCC
Installation	Desk type
Document alignment	Center

### B. Paper

Type	Size	Capacity
Plain paper (60 to 90 g/m <sup>2</sup> (16 to 24 lb))	A4, 8-1/2 x 11	2,500 sheets
Thick paper 1 (91 to 150 g/m <sup>2</sup> (24.25 to 40 lb))		1,000 sheets
Thick paper 2 (151 to 209 g/m <sup>2</sup> (40 to 55.5 lb))		
Thick paper 3 (210 to 256 g/m <sup>2</sup> (55.75 to 68 lb))		

### C. Machine specifications

Power requirements	DC 24 V $\pm$ 10% (supplied from the main body)
	DC 5 V $\pm$ 5%
Max. power consumption	45 W or less
 Dimensions	600 mm (W) x 578 mm (D) x 301 mm (H) 23.5 inch (W) x 22.75 inch (D) x 11.75 inch (H)
Weight	28.0 kg (61.75 lb)

### D. Operating environment

Conforms to the operating environment of the main body.

#### NOTE

- These specifications are subject to change without notice.



Blank Page

# Maintenance

## 2. Periodical check

### 2.1 Maintenance procedure (Periodical check parts)

#### 2.1.1 Replacing the separation roller assy

##### A. Periodically replaced parts/cycle

- Separation roller assy: Every 300,000 prints

##### NOTE

- **Replace the separation roller assy, feed roller and pick-up roller at the same time.**

##### B. Replacing procedure

1. Remove the right door.

See P.12

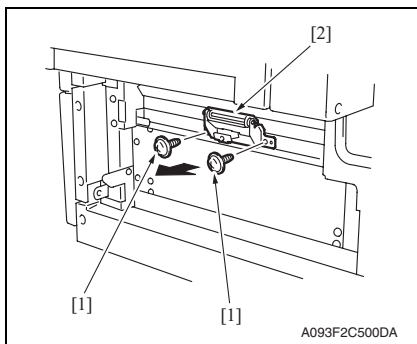

2. Remove two screws [1] and remove the separation roller mounting bracket assy [2].

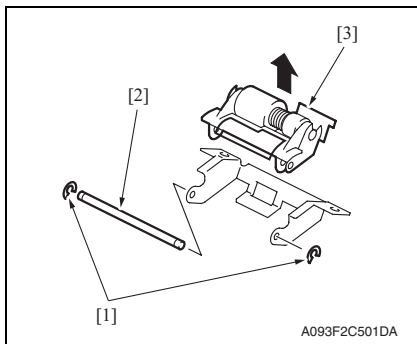

3. Remove two C-rings [1] and the shaft [2], and remove the separation roller fixing bracket assy [3].

##### NOTE

- **Be careful not to lose spring at this time.**

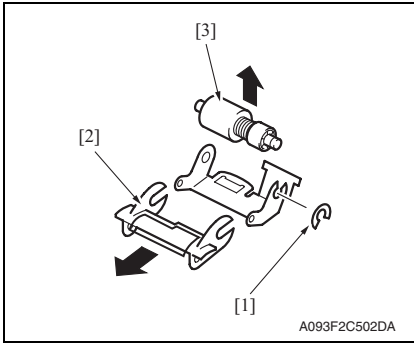

4. Remove the C-ring [1], the guide [2], and remove the separation roller assy [3].

**NOTE**

- Install the separation roller assy while pressing the holder down so that it aligns to the metal bracket of the machine.
- Make sure that the separation roller assy is not tilted to the right or left when installed.

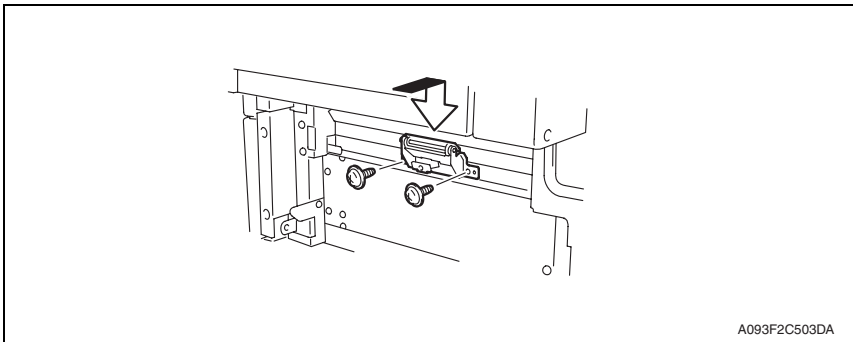

### 2.1.2 Replacing the feed roller

#### A. Periodically replaced parts/cycle

- Feed roller: Every 300,000 prints

#### NOTE

- **Replace the separation roller assy, feed roller and pick-up roller at the same time.**

#### B. Replacing procedure

1. Remove the right door.  
[See P.12](#)
2. Remove the rear cover and the rear right cover.  
[See P.12](#)

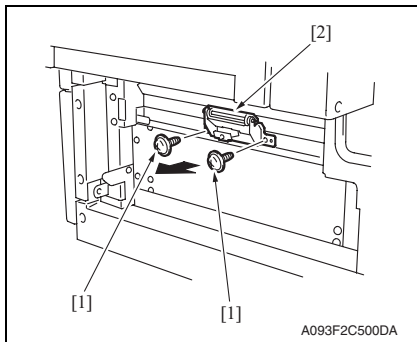

3. Remove two screws [1] and separation roller mounting bracket assy [2].

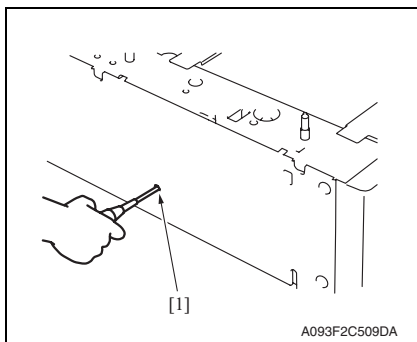

4. Insert a driver into the hole [1] at the back of the feed tray and pull out the paper feed tray.

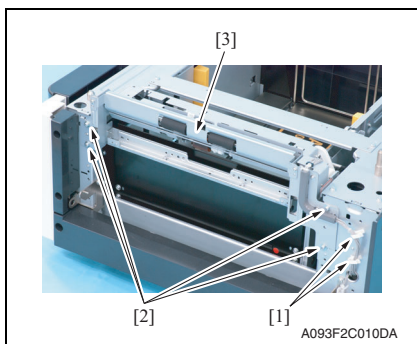

5. Remove two wire saddles [1] and four screws [2], and remove the paper feed unit [3].

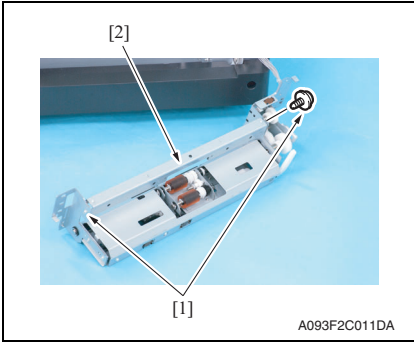

- 6. Remove two screws [1] and remove the mounting frame [2] for the separation roller mounting bracket assy.

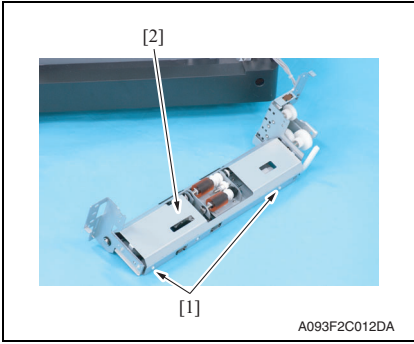

- 7. Remove two screws [1] and remove the paper feed roller cover [2].

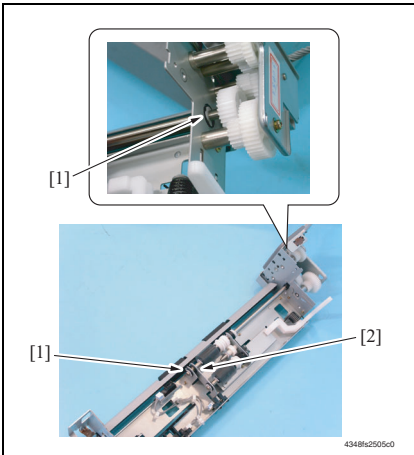

- 8. Remove two C-rings [1] and remove the bushing [2].

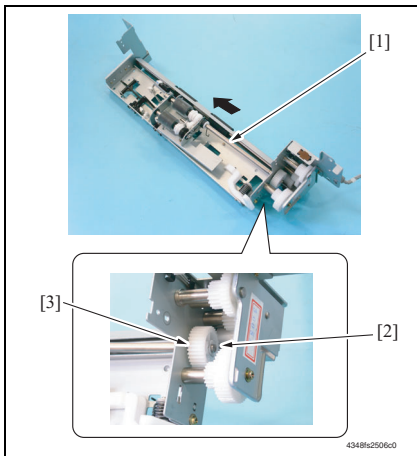

- 9. Shift the shaft assy [1] in the orientation as shown on the left, and remove the C-ring [2] and the gear [3].
- 10. Remove the shaft assy [1].

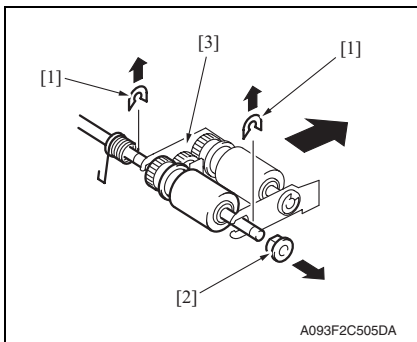

- 11. Remove two E-rings [1] and the bushing [2], and remove the pick-up roller fixing bracket assy [3].

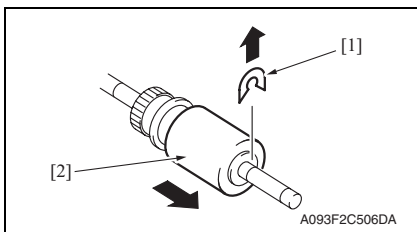

- 12. Remove the C-ring [1] and remove the feed roller [2].

### 2.1.3 Replacing the pick-up roller

#### A. Periodically replaced parts/cycle

- Pick-up roller: Every 300,000 prints

#### NOTE

- **Replace the separation roller assy, feed roller and pick-up roller at the same time.**

#### B. Replacing procedure

1. Remove the right door.  
[See P.12](#)
2. Remove the rear cover and the rear right cover.  
[See P.12](#)

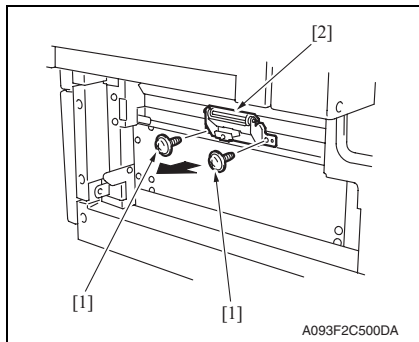

3. Remove two screws [1] and separation roller mounting bracket assy [2].

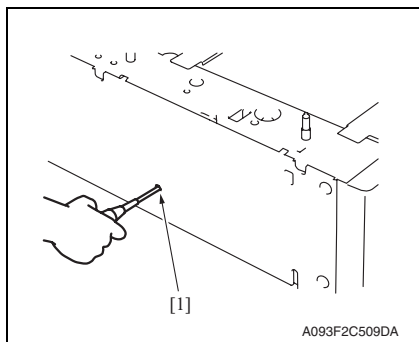

4. Insert a driver into the hole [1] at the back of the feed tray and pull out the paper feed tray.

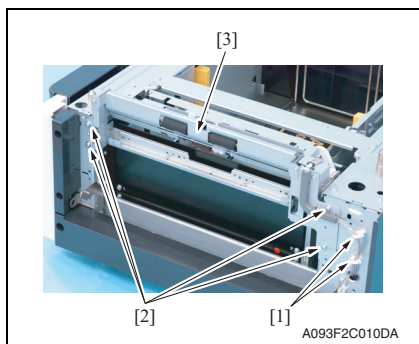

5. Remove two wire saddles [1] and four screws [2], and remove the paper feed unit [3].

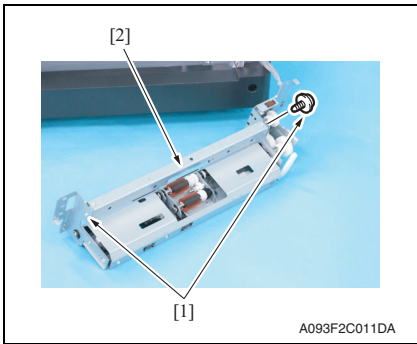

- 6. Remove two screws [1] and remove the mounting frame [2] for the separation roller mounting bracket assy.

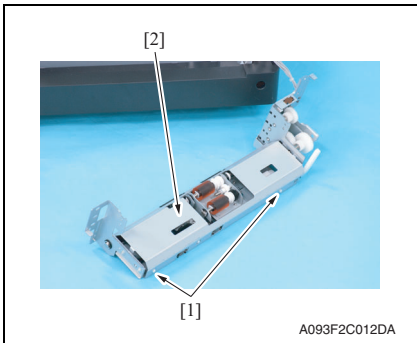

- 7. Remove two screws [1] and remove the paper feed roller cover [2].

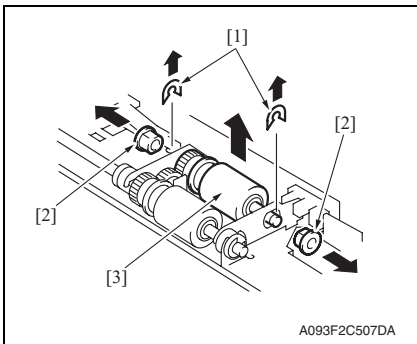

- 8. Remove two C-rings [1], two bushings [2], and the pick-up roller assy [3].

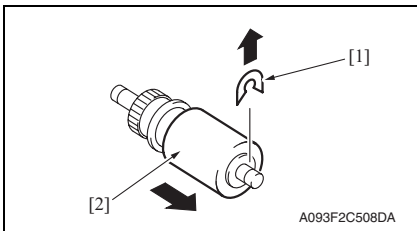

- 9. Remove the C-ring [1] and remove the pick-up roller [2].



## 3. Other

### 3.1 Disassembly/adjustment prohibited items

#### A. Paint-locked screws

##### NOTE

- To prevent loose screws, a screw lock in blue or green series color is applied to the screws.
- The screw lock is applied to the screws that may get loose due to the vibrations and loads created by the use of machine or due to the vibrations created during transportation.
- If the screw lock coated screws are loosened or removed, be sure to apply a screw lock after the screws are tightened.

#### B. Red-painted screws

##### NOTE

- The screws which are difficult to be adjusted in the field are painted in red in order to prevent them from being removed by mistake.
- Do not remove or loosen any of the red-painted screws in the field. It should also be noted that, when two or more screws are used for a single part, only one representative screw may be marked with the red paint.

#### C. Variable resistors on board

##### NOTE

- Do not turn the variable resistors on boards for which no adjusting instructions are given in Adjustment/Setting.

#### D. Removal of PWBs

##### CAUTION

- When removing a circuit board or other electrical component, refer to “Handling of PWBs” and follow the corresponding removal procedures.
- The removal procedures given in the following omit the removal of connectors and screws securing the circuit board support or circuit board.
- Where it is absolutely necessary to touch the ICs and other electrical components on the board, be sure to ground your body.

## 3.2 Disassembly/Assembly/Cleaning list (Other parts)

### 3.2.1 Disassembly/Assembly parts list

No.	Section	Part name	Ref. page
1	Exterior parts	Right door	<a href="#">P.12</a>
2		Rear right cover	<a href="#">P.12</a>
3		Lower right cover	<a href="#">P.12</a>
4		Front right cover	<a href="#">P.12</a>
5		Rear cover	<a href="#">P.12</a>
6		Left cover	<a href="#">P.12</a>
7	Unit	Drawer	<a href="#">P.13</a>
8	Other	Wire	<a href="#">P.14</a>

### 3.2.2 Cleaning parts list

No.	Section	Part name	Ref. page
1	Feed section	Separation roller	<a href="#">P.18</a>
2		Feed roller	<a href="#">P.18</a>
3		Pick-up roller	<a href="#">P.19</a>
4	Transport section	Vertical transport roller	<a href="#">P.20</a>

### 3.3 Disassembly/Assembly procedure

#### 3.3.1 Right door/Rear right cover/Lower right cover/Front right cover

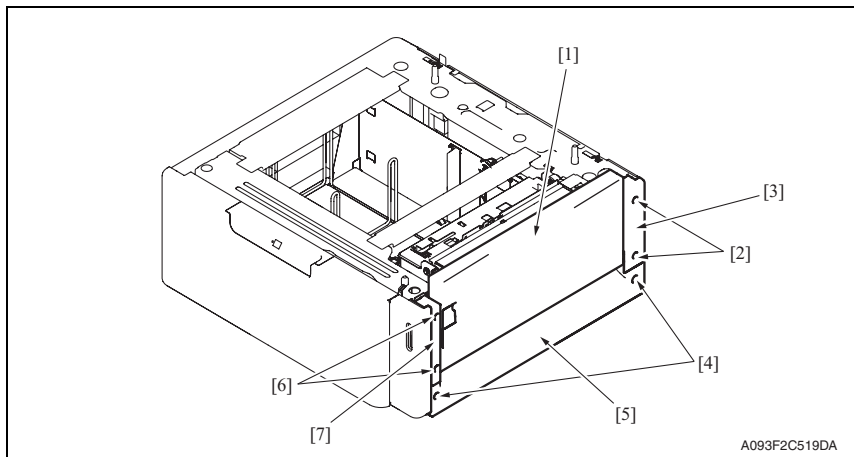

1. Open the right door [1].
2. Remove the right door [1].
3. Remove two screws [2] and remove the rear right cover [3].
4. Remove two screws [4] and remove the lower right cover [5].
5. Remove two screws [6] and remove the front right cover [7].

#### 3.3.2 Rear cover/Left cover

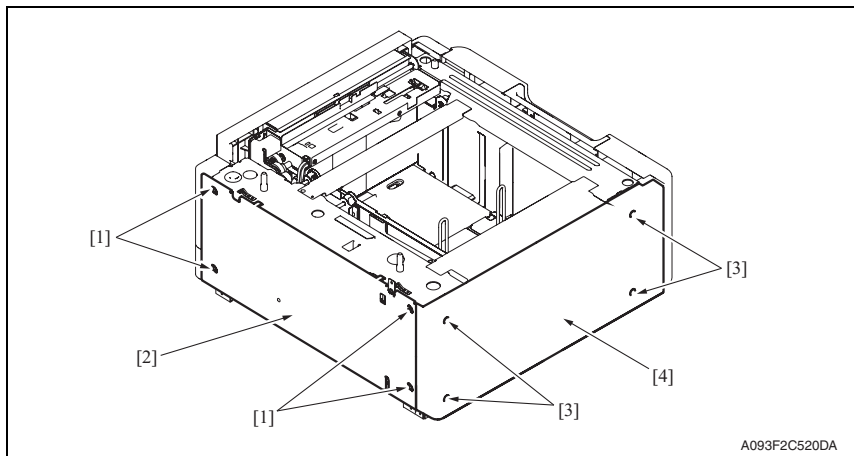

1. Remove four screws [1] and remove the rear cover [2].
2. Remove four screws [3] and remove the left cover [4].

### 3.3.3 Drawer

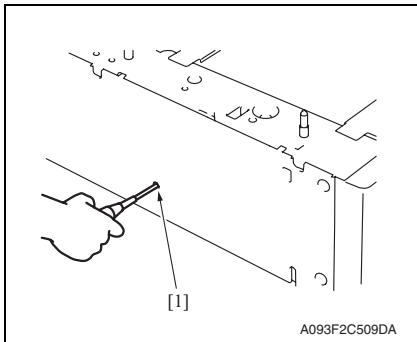

1. Insert a driver into the hole [1] at the back of the feed tray and pull out the paper feed tray.

2. Remove the paper.

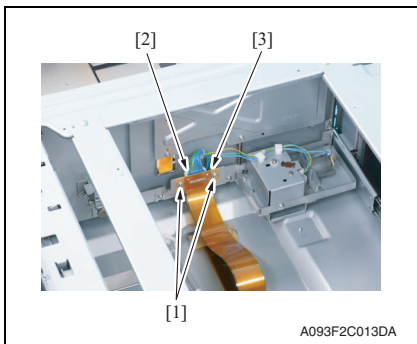

3. Remove two screws [1], the connector [2], and remove the connector board [3].

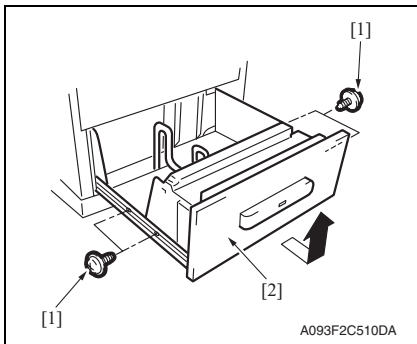

4. Remove four screws [1] and remove the drawer [2].

#### NOTE

- When removing the drawer, be careful not to drop the drawer from the guide rails.

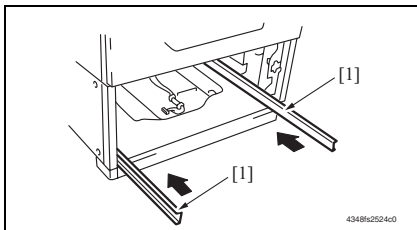

#### CAUTION

- To prevent injuries, slide the guide rail [1] into the machine.

### 3.3.4 Wire

1. Remove the drawer.  
See P.13

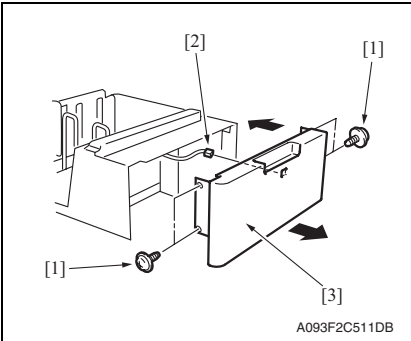

2. Remove four screws [1] and disconnect the connector [2], and remove the front cover assy [3].

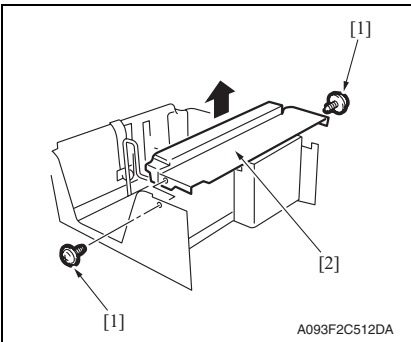

3. Remove two screws [1] and the inner cover assy [2].

**NOTE**

- Do not peel off pulley protective mylar sheet.

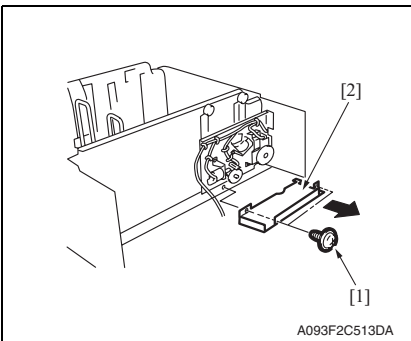

4. Remove two screws [1] and remove the driver cover [2].

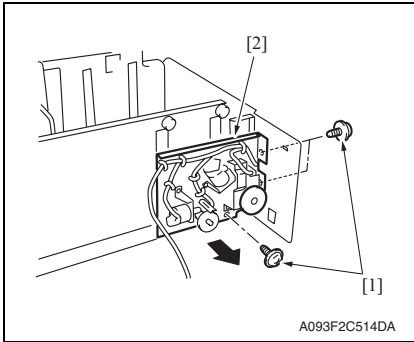

5. Remove three screws [1] and remove the driver mounting plate assy [2].

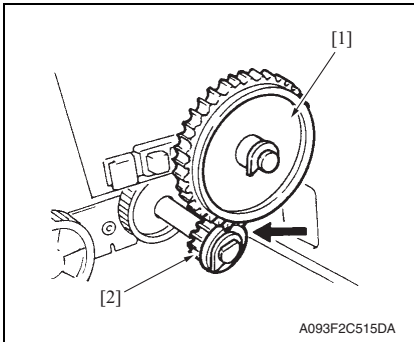

**NOTE**

- When assembling, be sure to engage rib of gear 1 [1] with convex section of gear 2 [2].

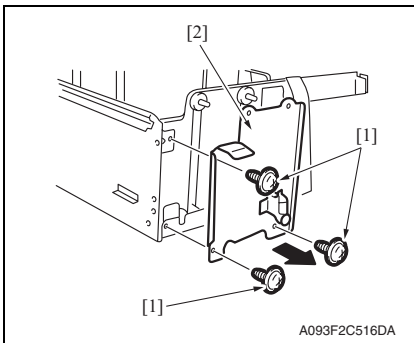

6. Remove three screws [1] and remove the reinforcement bracket assy [2].

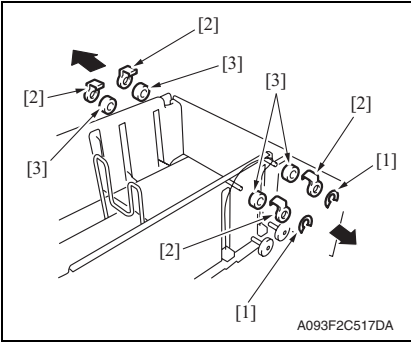

7. Remove two C-clips [1].
8. Remove four pulley covers [2].
9. Unhook four pulleys [3].

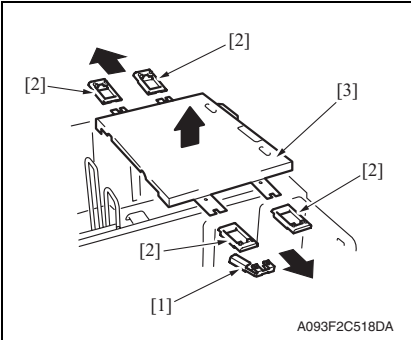

10. Remove the ground plate [1].
11. Remove four cable holding jigs [2] and remove the main drawer [3].

**NOTE**

- Use care not to bend the wires.

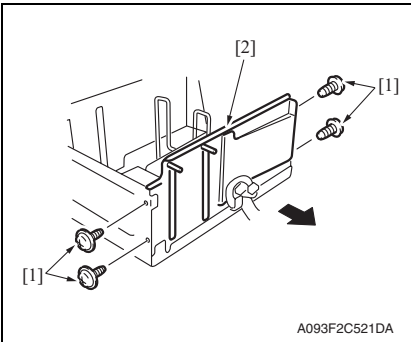

12. Remove four screws [1] and remove the rear trailing edge assy [2].

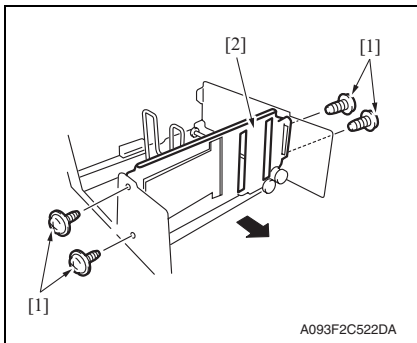

13. Remove four screws [1] and remove the front trailing edge assy [2].

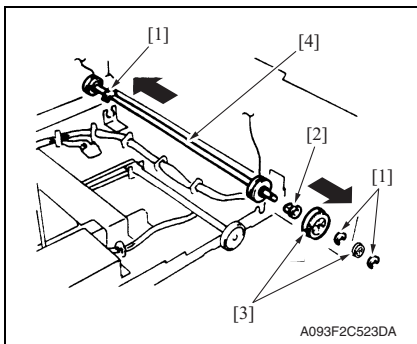

14. Remove three C-rings [1], the bushing [2], and two gears [3].

15. Remove the feed drum assy [4].

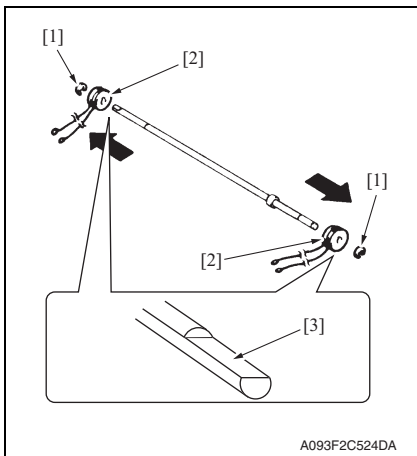

16. Remove two C-rings [1] and two feed drums [2].

**NOTE**

- Take care not to lose fixing pins.
- When reinstalling the feed drum, check that the direction of the wire coming from both feed drums are the same.
- Install so that cut parts [3] at both ends of shaft face up.



### 3.4 Cleaning procedure

#### NOTE

- The alcohol described in the cleaning procedure represents the isopropyl alcohol.

#### 3.4.1 Separation roller

1. Remove the right door.  
See P.12

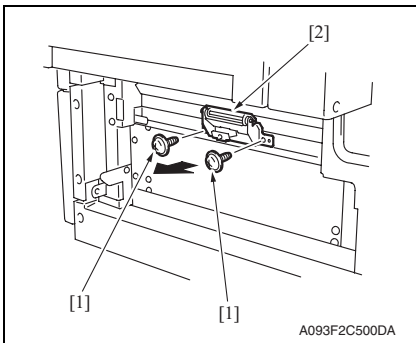

2. Remove two screws [1] and separation roller mounting bracket assy [2].

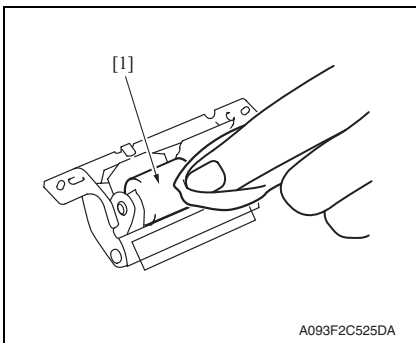

3. Using a cleaning pad dampened with alcohol, wipe the separation roller [1] clean of dirt.

#### 3.4.2 Feed roller

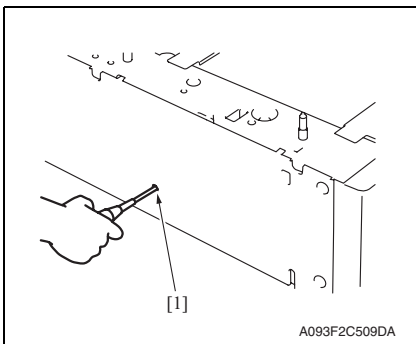

1. Insert a driver into the hole [1] at the back of the feed tray and pull out the paper feed tray.

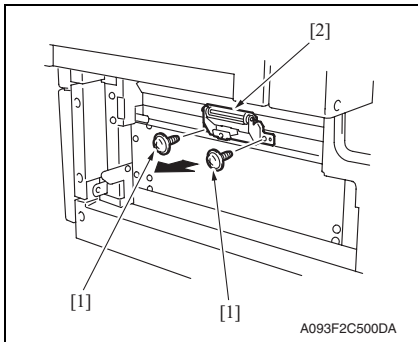

- 2. Remove two screws [1] and separation roller mounting bracket assy [2].

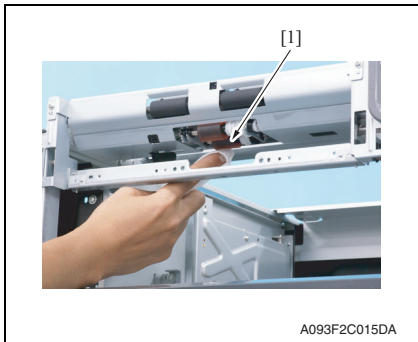

- 3. Using a cleaning pad dampened with alcohol, wipe the feed roller [1] clean of dirt.

### 3.4.3 Pick-up roller

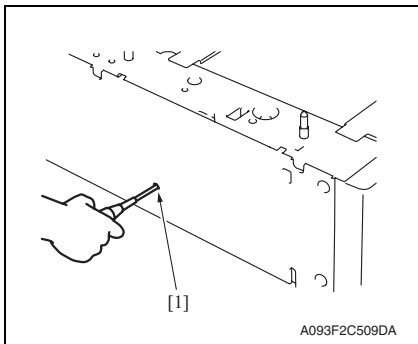

- 1. Insert a driver into the hole [1] at the back of the feed tray and pull out the paper feed tray.

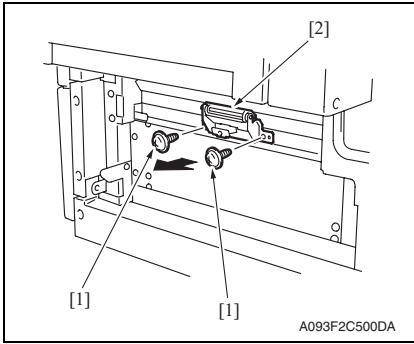

2. Remove two screws [1] and separation roller mounting bracket assy [2].

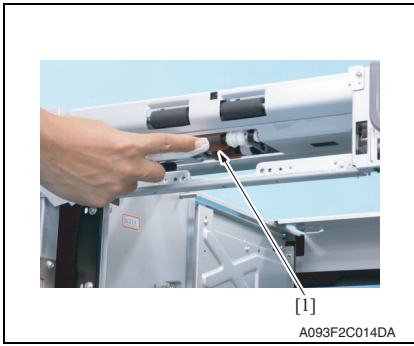

3. Using a cleaning pad dampened with alcohol, wipe the pick-up roller [1] clean of dirt.

### 3.4.4 Vertical transport roller

1. Open the right door.

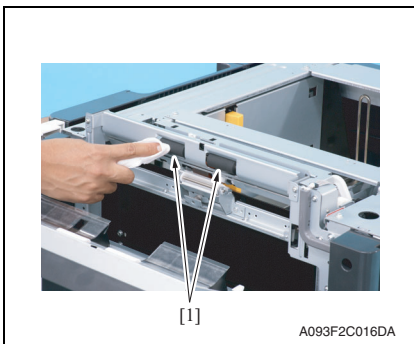

2. Using a cleaning pad dampened with alcohol, wipe the vertical transport roller [1] clean of dirt.

## Adjustment/Setting

### 4. How to use the adjustment section

- “Adjustment/Setting” contains detailed information on the adjustment items and procedures for this machine.
- Throughout this “Adjustment/Setting,” the default settings are indicated by “ ”.

#### Advance checks

Before attempting to solve the customer problem, the following advance checks must be made. Check to see if:

- The power supply voltage meets the specifications.
- The power supply is properly grounded.
- The machine shares the power supply with any other machine that draws large current intermittently (e.g., elevator and air conditioner that generate electric noise).
- The installation site is environmentally appropriate: high temperature, high humidity, direct sunlight, ventilation, etc.; levelness of the installation site.
- The original has a problem that may cause a defective image.
- The density is properly selected.
- The original glass, slit glass, or related part is dirty.
- Correct paper is being used for printing.
- The units, parts, and supplies used for printing (developer, PC drum, etc.) are properly replenished and replaced when they reach the end of their useful service life.
- Toner is not running out.

#### CAUTION

- **Be sure to unplug the power cord of the machine before starting the service job procedures.**
- **If it is unavoidably necessary to service the machine with its power turned ON, use utmost care not to be caught in the scanner cables or gears of the exposure unit.**
- **Special care should be used when handling the fusing unit which can be extremely hot.**
- **The developing unit has a strong magnetic field. Keep watches and measuring instruments away from it.**
- **Take care not to damage the PC drum with a tool or similar device.**
- **Do not touch IC pins with bare hands.**

# 5. Sensor check

## 5.1 Check procedure

### A. Procedure

1. Call the Service Mode to the screen.  
[See P.338 of the main body service manual.](#)
2. Touch [State Confirmation].
3. Touch [Sensor Check].
4. Touch [▼]once.

### 5.1.1 Sensor check screen

- This is only typical screen which may be different from what are shown on each individual main body.

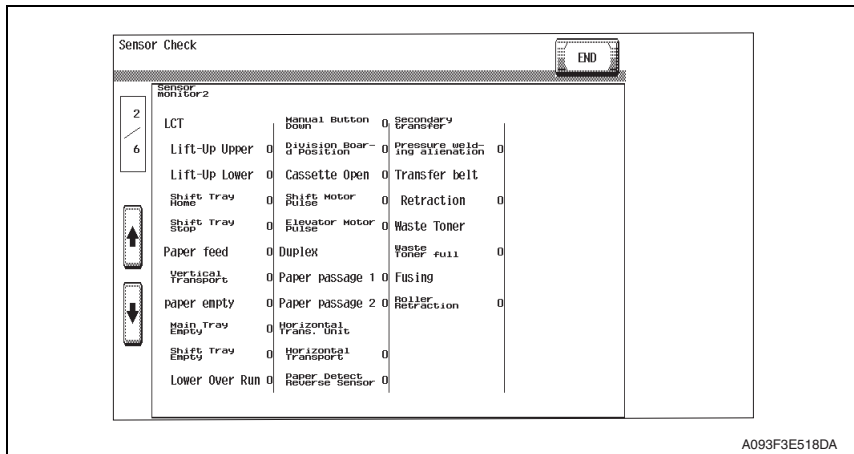

A093F3E518DA

**5.1.2 Sensor check list**

**A. Sensor monitor 2**

Symbol	Panel display	Part/Signal name	Operation characteristics/ panel display	
			1	0
PS4	Lift-Up Upper	Lift-up upper sensor	Raised Position	Not raised
PS13	Lift-Up Lower	Lift-up lower sensor	Lowered Position	Not lowered
PS12	Shift Tray Home	Shift tray home sensor	At home	Not at home
PS11	Shift Tray Stop	Shift tray stop sensor	Return position	Not at return position
PS1	Paper feed	Paper feed sensor	Paper present	Paper not present
PS2	Vertical Transport	Vertical transport sensor	Paper present	Paper not present
PS3	Paper empty	Paper empty sensor	Paper present	Paper not present
MTPEB	Main Tray Empty	Main tray paper empty board	Paper present	Paper not present
PS9	Shift Tray Empty	Shift tray empty sensor	Paper present	Paper not present
PS7	Lower Over Run	Lower over run sensor	malfunction	operational
MDCB	Manual Button Down	Manual down control board	ON	OFF
PS14	Division Board Position	Division board position sensor	At home	Not at home
PS6	Cassette Open	Cassette open sensor	Set	Out of position
PS8	Shift Motor Pulse	Shift motor pulse sensor	Blocked	Unblocked
PS10	Elevator Motor Pulse	Elevator motor pulse sensor	Blocked	Unblocked

# 6. Mechanical adjustment

## 6.1 Adjusting the paper reference position

### NOTE

- Make this adjustment after any of the following procedures has been performed.
  - When the PH unit has been replaced.
  - When the image on the print is offset in the sub scan direction.
  - When a faint image occurs on the leading edge of the image.

### 6.1.1 Centering

1. Call the Service Mode to the screen.  
[See P.338 of the main body service manual.](#)
2. Touch [Machine] → [Printer Area].
3. Touch [Centering] → [3rd.].

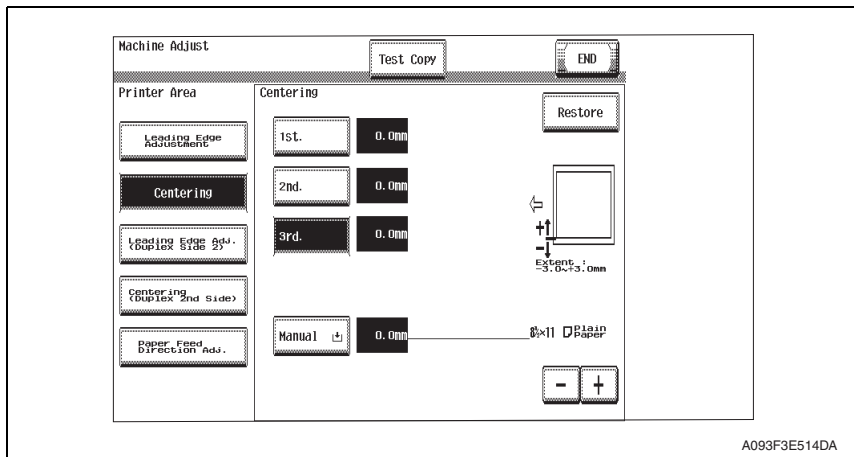

4. Press the Start key to let the machine produce a test print.

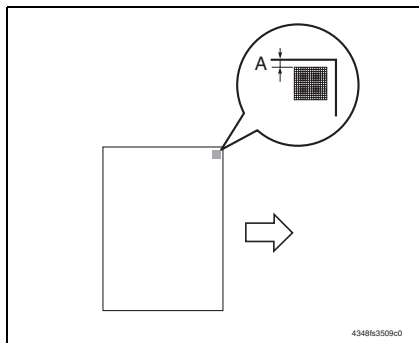

5. Measure the width of printed reference line A.  
Specification: 3.0 mm ± 1.0 mm
6. If the measured width A falls outside the specified range, enter the correction value using the [-] or [+] key.
7. Produce another test print and check to see if width A falls within the specified range.

### NOTE

- If the use of the [-] or [+] key does not allow the measurement to fall within the specified range, perform the following steps.

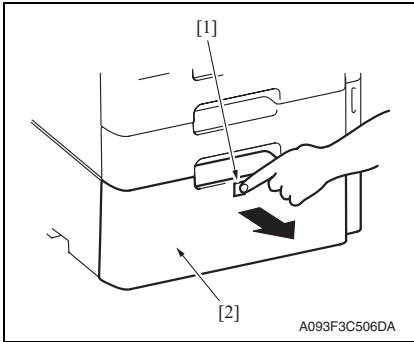

8. Press the drawer release button [1] and then slide out the drawer [2] from the paper feed cabinet.

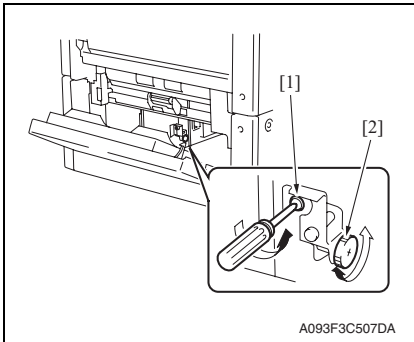

9. Open the right door.
10. Loosen the adjustment screw [1] and turn screw D [2] to make the adjustment.

**NOTE**

- Do not damage the passage surface of the right door.

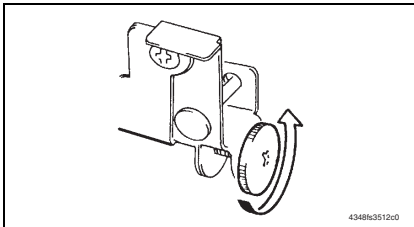

- If width A is greater than the specified value:  
Turn screw D counterclockwise.

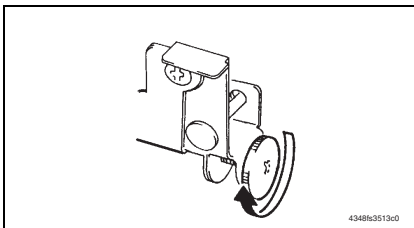

- If width A is smaller than the specified value:  
Turn screw D clockwise.

11. Perform another test print and check the reference deviation.
12. Repeat the adjustment until the reference line falls within the specified range.
13. Tighten the adjustment screw.
14. Touch [END].
15. Touch [Exit] on the Service Mode screen.
16. Turn OFF the main power switch, then wait for 10 sec. or more and turn ON the main power switch.



### 6.1.2 Centering (Duplex 2nd Side)

1. Call the Service Mode to the screen.  
[See P.338 of the main body service manual.](#)
2. Touch [Machine] → [Printer Area].
3. Touch [Centering (Duplex 2nd Side)] → [3rd.].

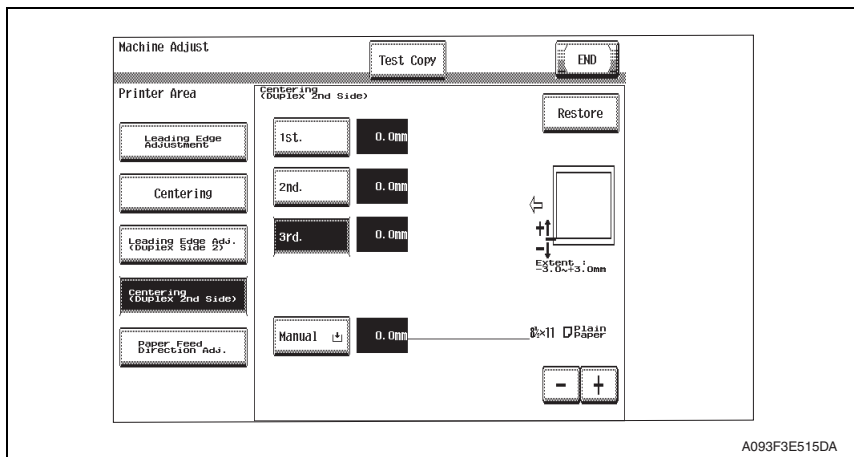

A093F3E515DA

4. Press the Start key to let the machine produce a test print.

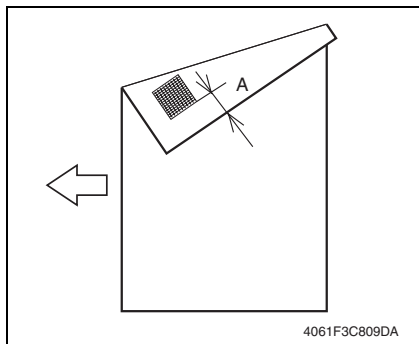

4061F3C809DA

5. Measure the width of printed reference line A.  
Specification: 3.0 mm ± 2.0 mm
6. If the measured width A falls outside the specified range, enter the correction value using the [-] or [+] key.
7. Produce another test print and check to see if width A falls within the specified range.

8. Touch [END].
9. Touch [Exit] on the Service Mode screen.
10. Turn OFF the main power switch, then wait for 10 sec. or more and turn ON the main power switch.

## 6.2 Shifter movement timing belt adjustment

1. Remove the drawer.

See P.13

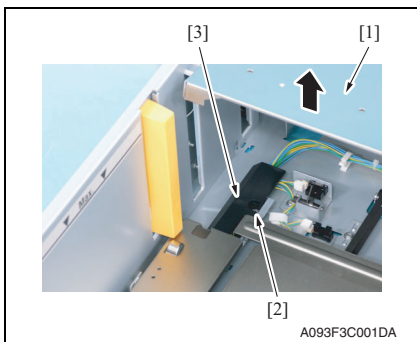

2. While raising the main tray [1], remove the screw [2] and the connector cover [3].

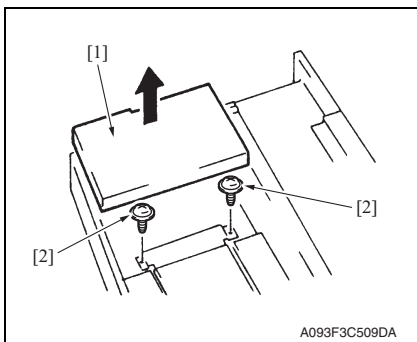

3. While raising the main tray [1], remove two screws [2] that hold the shift tray in position.

### NOTE

- When reinstalling, use caution because the wire of the main tray [1] comes off easily.

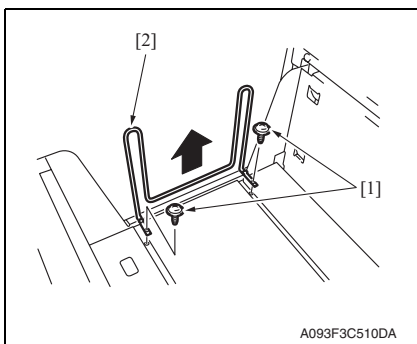

4. Remove two screws [1] and remove the shifter [2].

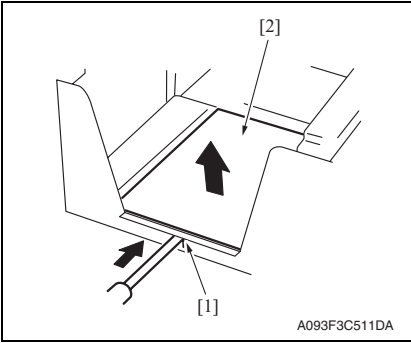

5. Push the tab [1] of the shift tray [2] as shown on the left and release the lock.
6. Remove the shift tray [2].

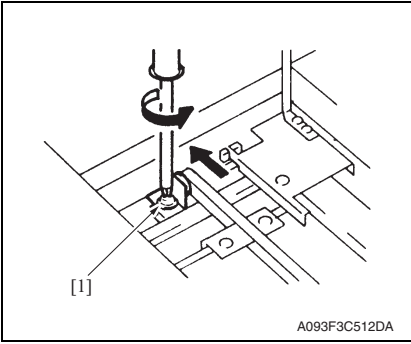

7. Loosen the screw [1] fixing the tension pulley assy as shown on the left and move it in the direction of the arrow.
8. After moving the shifter, tighten the fixing screw [1].

# Troubleshooting

## 7. Jam display

### 7.1 Misfeed display

- When misfeed occurs, message, misfeed location “Blinking” and paper location “Lighting” are displayed on the touch panel of the main body.

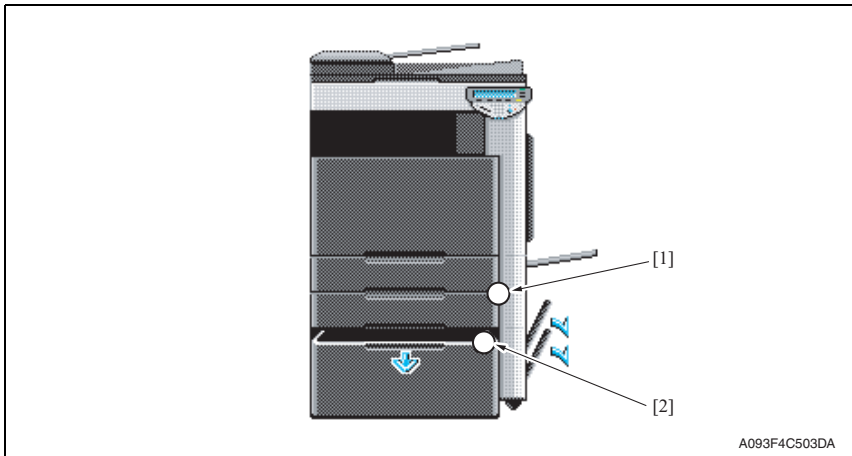

No.	Code	Misfeed location	Misfeed access location	Action
[2]	1501	LCT paper feed section	Right door	P.32
[1]	2001	LCT paper vertical transport section	Vertical transport door	

#### 7.1.1 Misfeed display resetting procedure

- Open the corresponding door, clear the sheet of paper misfed, and close the door.



### 7.2 Sensor layout

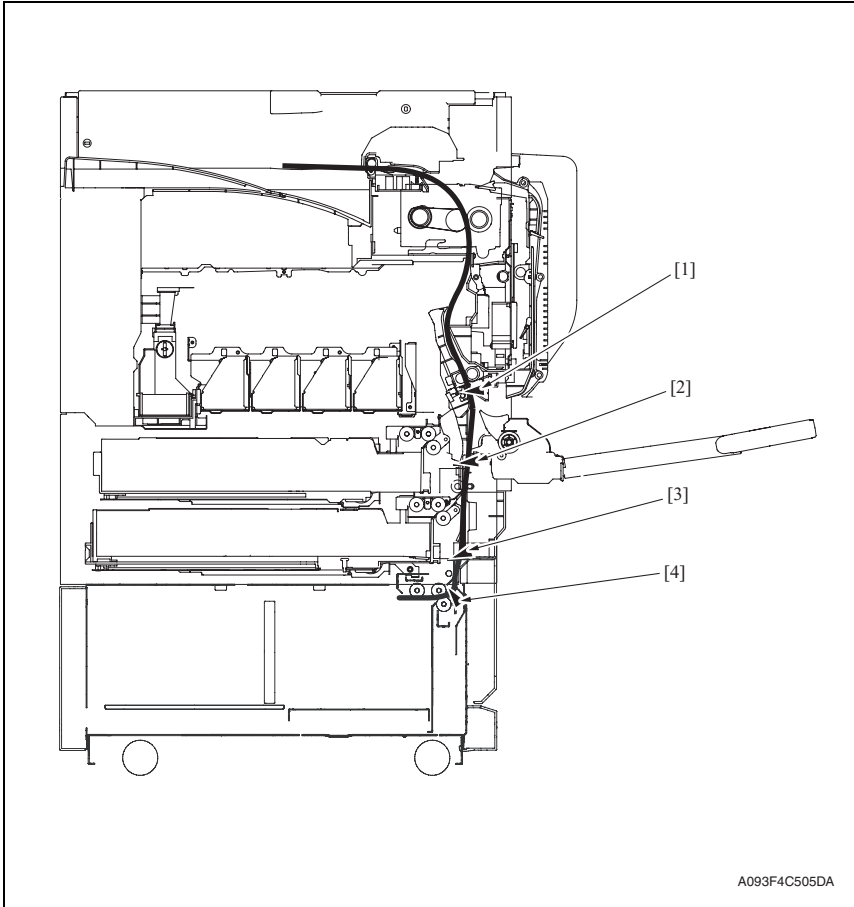

A093F4C505DA

- |   |      |                               |     |
|---|------|-------------------------------|-----|
| [1] Sensor in front of tim. roller              | PS23 | [3] Vertical transport sensor | PS2 |
| [2] Paper feed tray 2 vertical transport sensor | PS16 | [4] Paper feed sensor         | PS1 |

## 7.3 Solution

### 7.3.1 Initial check items

- When a paper misfeed occurs, first perform the following initial check items.

Check item	Action
Does paper meet product specifications?	Replace paper.
Is the paper curled, wavy, or damp?	Replace paper. Instruct the user on the correct paper storage procedures.
Is a foreign object present along the paper path, or is the paper path deformed or worn?	Clean the paper path and replace if necessary.
Are rolls/rollers dirty, deformed, or worn?	Clean or replace the defective roll/roller.
Are the edge guide and trailing edge stop at the correct position to accommodate the paper?	Set as necessary.
Are the actuators operating correctly?	Correct or replace the defective actuator.

**7.3.2 LCT paper feed section/vertical transport section misfeed**

**A. Detection timing**

Type	Description
LCT paper feed section misfeed detection	The leading edge of the paper does not block the paper feed sensor (PS1) or the vertical transport sensor (PS2) even after the set period of time has elapsed after the paper feed motor (M1) is energized.
LCT vertical transport section misfeed detection	The paper feed tray 2 vertical transport sensor (PS16) is not blocked even after the lapse of a given period of time after the vertical transport sensor (PS2) has been blocked by a paper.
LCT vertical transport section loop registration reversing jam	Rise timing of load for registration is earlier than the one for making the loop at front of the timing roller at LCT paper feed.
LCT detection of paper remaining	The vertical transport sensor (PS2) is blocked when the main power switch is set to ON, a door or cover is opened and closed, or a misfeed or malfunction is reset.
	The paper feed sensor (PS1) is blocked when the main power switch is set to ON, a door or cover is opened and closed, or a misfeed or malfunction is reset.
Misfeed detected as a result of delayed deactivation of sensor	The paper feed sensor (PS1) is not unblocked even after the lapse of a given period of time after PS1 has been blocked by a paper.
	The vertical transport sensor (PS2) is not unblocked even after the lapse of a given period of time after PS2 has been blocked by a paper.
LCT feed section image write start signal permit waiting jam	For paper fed from the LCT, image write start signal permit continues to be disabled for a predetermined period of time after the timing of image write start signal output.

**B. Action**

Relevant electrical parts	
Paper feed sensor (PS1) Vertical transport sensor (PS2) Paper feed tray 2 vertical transport sensor (PS16) Paper feed motor (M1) Sensor in front of tim. roller (PS23)	PC control board (PCCB) MFP board (MFPB)

Step	Action	WIRING DIAGRAM	
		Control signal	Location (Electrical components)
1	Initial check items	—	—
2	PS23 I/O check, sensor check	PRCB CN1-3 (ON)	bizhub C353/C253/C203 D-18
3	PS1 I/O check, sensor check	PCCB PJ5-2 (ON)	PC-405 F-9
4	PS2 I/O check, sensor check	PCCB PJ5-5 (ON)	PC-405 F-9
5	PS16 I/O check, sensor check	PCCB CN9-11 (ON)	bizhub C353/C253/C203 D-10
6	M1 operation check	PCCB PJ6-1 to 4	PC-405 F-10
7	PCCB replacement	—	—
8	MFPB replacement	—	—

## 8. Trouble code

### 8.1 Trouble code display

- The main unit's CPU performs a self-diagnostics function that, on detecting a malfunction, gives the corresponding malfunction code on the touch panel.

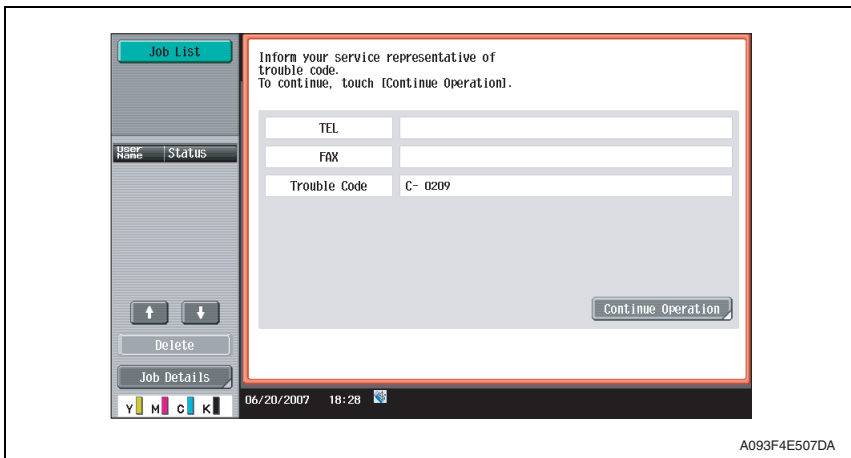



## 8.2 Trouble code list

Code	Item	Description
C0001	LCT communication error	<ul style="list-style-type: none"> <li>Due to a software malfunction, etc., the time on the watchdog timer has run out and a reset is performed.</li> </ul>
C0102	LCT vertical transport motor malfunction	<ul style="list-style-type: none"> <li>The lock signal remains high for a predetermined continuous period of time while the LCT vertical transport motor is turning.</li> </ul>
C0209	LCT elevator motor failure	<ul style="list-style-type: none"> <li>The elevator motor pulse sensor (PS10) cannot detect both edges of H/L even after the set period of time has elapsed while the elevator motor (M5) is turning backward/forward (raise/lower).</li> </ul>
C0210	LCT lift failure	<ul style="list-style-type: none"> <li>The lift-up upper sensor (PS4) is not blocked even after the set period of time has elapsed after the paper lift-up operation began.</li> <li>The lift-up upper sensor (PS4) is not blocked even after the set pulse is detected by the elevator motor pulse sensor (PS10) after the paper lift-up operation began.</li> <li>The lift-up lower sensor (PS13) is not unblocked even after the set pulse is detected by the elevator motor pulse sensor (PS10) after the paper lift-up operation began.</li> <li>The lift-up upper sensor (PS4) is not blocked even after the set period of time has elapsed after the paper lift-up operating.</li> <li>The lift-up lower sensor (PS13) is not blocked even after the set period of time has elapsed after the paper lift-down operation began.</li> <li>The lift-up lower sensor (PS13) is not blocked even after the set pulse is detected by the elevator motor pulse sensor (PS10) after the paper lift-down operation began.</li> <li>The lift-up upper sensor (PS4) is not unblocked even after the set pulse is detected by the elevator motor pulse sensor (PS10) after the paper lift-down operation began.</li> <li>The lower over run sensor (PS7) is blocked while the paper lift-down operating.</li> </ul>
C0212	LCT ejection failure	<ul style="list-style-type: none"> <li>The drawer cannot be determined to be out of position even after the set period of time has elapsed after the tray lock solenoid (SD1) is energized after the lowering operation is finished.</li> </ul>
C0213	LCT shift gate malfunction	<ul style="list-style-type: none"> <li>The division board position sensor (PS14) cannot be set to L even after the set period of time has elapsed after the operation of the division board position motor (M3) began with the division board position sensor (PS14) set to L.</li> </ul>

Code	Item	Description
C0214	LCT shifting failure	<ul style="list-style-type: none"> <li>• The shift tray stop sensor (PS11) is not blocked even after the set period of time has elapsed after the shift operation began (shift to the right).</li> <li>• The shift tray stop sensor (PS11) is not blocked even after the set pulse is detected by the shift motor pulse sensor (PS8) after the shift operation began (shift to the right).</li> <li>• The shift tray home sensor (PS12) is not unblocked even after the set pulse is detected by the shift motor pulse sensor (PS8) after the shift operation began (shift to the right).</li> <li>• The shift tray home sensor (PS12) is not blocked even after the set period of time has elapsed after the return operation began (shift to the left).</li> <li>• The shift tray home sensor (PS12) is not blocked even after the set pulse is detected by the shift motor pulse sensor (PS8) after the return operation began (shift to the left).</li> <li>• The shift tray stop sensor (PS11) is not unblocked even after the set pulse is detected by the shift motor pulse sensor (PS8) after the return operation began (shift to the left).</li> </ul>
C0215	LCT shift motor malfunction	<ul style="list-style-type: none"> <li>• The shift motor pulse sensor (PS8) cannot detect both edges of H/L even after the set period of time has elapsed while the shift motor (M4) is turning backward/forward (raise/lower).</li> </ul>

- Open and close the front door, or turn OFF the main power switch. Then, wait for 10 sec. or more and turn ON the main power switch to reset the malfunction display.

### 8.3 Solution

#### 8.3.1 C0001: LCT communication error

Relevant electrical parts			
PC control board (PCCB)			
Step	Action	WIRING DIAGRAM	
		Control signal	Location (Electrical components)
1	Turn OFF the main power switch, wait for 10 sec. or more, and turn ON the main power switch.	—	—
2	PCCB replacement	—	—

#### 8.3.2 C0209: LCT elevator motor failure

Relevant electrical parts	
Elevator motor (M5) Elevator motor pulse sensor (PS10)	Relay board (REYB) PC control board (PCCB)



Step	Action	WIRING DIAGRAM	
		Control signal	Location (Electrical components)
1	Check the motor and sensor connectors for proper connection, and correct as necessary.	—	—
2	Check the connector of motor for proper drive coupling, and correct as necessary.	—	—
3	PS10 I/O check, sensor check	REYB PJ2<A>-5 (ON)	PC-405 K-5
4	M5 operation check	REYB PJ2<B>-6 to 7	PC-405 K-6 to 7
5	REYB replacement	—	—
6	PCCB replacement	—	—

**8.3.3 C0210: LCT lift failure**

Relevant electrical parts	
Lift-up upper sensor (PS4) Lift-up lower sensor (PS13) Elevator motor pulse sensor (PS10) Lower over run sensor (PS7)	PC control board (PCCB)



Step	Action	WIRING DIAGRAM	
		Control signal	Location (Electrical components)
1	Check the sensor connectors for proper connection, and correct as necessary.	—	—
2	PS4 I/O check, sensor check	PCCB PJ5-12 (ON)	PC-405 F-8
3	PS13 I/O check, sensor check	REYB PJ2<A>-9 (ON)	PC-405 K-3
4	PS10 I/O check, sensor check	REYB PJ2<A>-5 (ON)	PC-405 K-5
5	PS7 I/O check, sensor check	REYB PJ2<A>-2 (ON)	PC-405 K-6
6	PCCB replacement	—	—

**8.3.4 C0212: LCT lock release failure**

Relevant electrical parts	
Tray lock solenoid (SD1)	PC control board (PCCB)



Step	Action	WIRING DIAGRAM	
		Control signal	Location (Electrical components)
1	Check the SD1 connector for proper connection, and correct as necessary.	—	—
2	SD1 operation check	PCCB PJ7-4 (ON)	PC-405 F-10
3	PCCB replacement	—	—

**8.3.5 C0213: LCT shift gate operation failure**

Relevant electrical parts	
Division board position sensor (PS14) Division board position motor (M3)	PC control board (PCCB)

Step	Action	WIRING DIAGRAM	
		Control signal	Location (Electrical components)
1	Check the motor and sensor connectors for proper connection, and correct as necessary.	—	—
2	Check the connector of motor for proper drive coupling, and correct as necessary.	—	—
3	PS14 I/O check, sensor check	REYB PJ2<B>-1 (ON)	PC-405 K-7
4	M3 operation check	REYB PJ2<B>-2 to 3	PC-405 K-7
5	PCCB replacement	—	—

**8.3.6 C0214: LCT shift failure**

Relevant electrical parts	
Shift motor pulse sensor (PS8) Shift tray stop sensor (PS11) Shift tray home sensor (PS12)	PC control board (PCCB)

Step	Action	WIRING DIAGRAM	
		Control signal	Location (Electrical components)
1	Check the sensor connectors for proper connection, and correct as necessary.	—	—
2	PS8 I/O check, sensor check	REYB PJ2<A>-3 (ON)	PC-405 K-6
3	PS11 I/O check, sensor check	REYB PJ2<A>-7 (ON)	PC-405 K-4
4	PS12 I/O check, sensor check	REYB PJ2<A>-8 (ON)	PC-405 K-4
5	PCCB replacement	—	—

**8.3.7 C0215: LCT shift motor failure**

Relevant electrical parts	
Shift motor (M4) Shift motor pulse sensor (PS8)	PC control board (PCCB)



Step	Action	WIRING DIAGRAM	
		Control signal	Location (Electrical components)
1	Check the motor and sensor connectors for proper connection, and correct as necessary.	—	—
2	Check the connector of motor for proper drive coupling, and correct as necessary.	—	—
3	PS8 I/O check, sensor check	REYB PJ2<A>-3 (ON)	PC-405 K-6
4	M4 operation check	REYB PJ2<B>-4 to 5	PC-405 K-7
5	PCCB replacement	—	—

Blank Page



KONICA MINOLTA

**SERVICE MANUAL**

**FIELD SERVICE**

---

# FS-519/PK-515 /OT-602







# Revision history

After publication of this service manual, the parts and mechanism may be subject to change for improvement of their performance.

Therefore, the descriptions given in this service manual may not coincide with the actual machine.

When any change has been made to the descriptions in the service manual, a revised version will be issued with a revision mark added as required.



Revision mark:

- To indicate clearly a specific section revised within text,  is shown at the left margin of the corresponding revised section.  
The number inside  represents the number of times the revision has been made.
- To indicate clearly a specific page that contains a revision or revisions, the page number appearing at the left or right bottom of the specific page is marked with .  
The number inside  represents the number of times the revision has been made.

## NOTE

Revision marks shown in a page are restricted only to the latest ones with the old ones deleted.

- When a page revised in Ver. 2.0 has been changed in Ver. 3.0:  
The revision marks for Ver. 3.0 only are shown with those for Ver. 2.0 deleted.
- When a page revised in Ver. 2.0 has not been changed in Ver. 3.0:  
The revision marks for Ver. 2.0 are left as they are.

2008/01	3.0		Error correction
2007/11	2.0		Error correction
2007/07	1.0	—	Issue of the first edition
Date	Service manual Ver.	Revision mark	Descriptions of revision

# CONTENTS

## FS-519/PK-515/OT-602

### General

- 1. Product specifications ..... 1
  - 1.1 FS-519 ..... 1
  - 1.2 PK-515 ..... 4
  - 1.3 OT-602 ..... 5

### Maintenance

- 2. Periodical check ..... 7
  - 2.1 Maintenance procedure (Periodical check parts) ..... 7
    - 2.1.1 Replacing the paddles ..... 7
    - 2.1.2 Replacing the cleaning pad ..... 10
    - 2.1.3 Lubricating the worm gear and replacing the cover film ..... 11
    - 2.1.4 Cleaning of the rollers and rolls ..... 14
    - 2.1.5 Cleaning of the paddles ..... 16
- 3. Other ..... 17
  - 3.1 Disassembly/adjustment prohibited items ..... 17
  - 3.2 Precautions to be observed when option configuration is changed ..... 18
    - 3.2.1 Setting the exit tray detection position ..... 18
  - 3.3 Disassembly/Assembly/Cleaning list (Other parts) ..... 19
    - 3.3.1 Disassembly/Assembly parts list ..... 19
  - 3.4 Disassembly/Assembly procedure ..... 20
    - 3.4.1 Finisher unit right front cover ..... 20
    - 3.4.2 Finisher unit left front cover ..... 20
    - 3.4.3 Finisher unit rear cover ..... 20
    - 3.4.4 Finisher unit upper cover ..... 21
    - 3.4.5 Front door ..... 21
    - 3.4.6 Middle guide ..... 22
    - 3.4.7 Intake cover ..... 23
    - 3.4.8 Tray unit front cover/Tray unit rear cover/Connector cover ..... 23
    - 3.4.9 Tray 1/Tray 2 ..... 24
    - 3.4.10 Output tray (OT-602): Option ..... 24
    - 3.4.11 Tray unit ..... 25
    - 3.4.12 Finisher unit ..... 28
    - 3.4.13 Changing the height of the stand table ..... 29

FS-519/PK-515/OT-602

General

Maintenance

Adjustment / Setting

Troubleshooting

3.4.14	Height and angle adjustment of stand table .....	34
3.4.15	Stapler unit.....	36
3.4.16	Punch kit (PK-515): Option .....	37
3.4.17	Exit roller motor/Storage paddle drive clutch/Exit upper roller/ Storage paddle .....	38
3.4.18	Exit paddle drive clutch/Exit lower roller .....	43
3.4.19	Aligning section.....	46
3.4.20	Elevator motor/Timing belt .....	49
3.4.21	Shutter drive gear .....	55
3.4.22	Duplex guide solenoid .....	56
3.4.23	FS control board .....	58

## Adjustment/Setting

4.	How to use the adjustment section .....	59
5.	Sensor Check .....	60
5.1	Check procedure .....	60
5.1.1	Sensor check screen .....	60
5.1.2	Sensor check list.....	61
6.	Finisher operations .....	62
6.1	CB-FN adjustment.....	62
6.1.1	Finisher Check.....	62
6.1.2	Punch Regist Loop Size .....	64
6.1.3	Punch Horizontal Position.....	65
6.2	Punch option setting.....	66
7.	Mechanical adjustment .....	67
7.1	Punch hole deviance adjustment (PK-515) .....	67
7.2	Staple position adjustment .....	68
7.3	Staple home position sensor position adjustment.....	70
7.4	Adjustment of clearance between stapler and FD stopper.....	71

## Troubleshooting

8.	Jam display .....	73
8.1	Misfeed display .....	73
8.1.1	Misfeed display resetting procedure .....	73
8.2	Sensor layout.....	74
8.3	Solution .....	75
8.3.1	Initial check items .....	75
8.3.2	Solution when paper curl occurs.....	75
8.3.3	Transport section misfeed.....	76

8.3.4	Exit section misfeed .....	77
8.3.5	Finisher bundle exit misfeed.....	77
8.3.6	Finisher staple misfeed .....	78
8.3.7	Finisher punch misfeed (PK-515).....	78
9.	Malfunction code .....	79
9.1	Trouble code .....	79
9.2	Solution.....	81
9.2.1	C1004: FNS communication error.....	81
9.2.2	C1183: Elevator motor ascent/descent drive failure.....	81
9.2.3	C1190: Aligning plate 1 drive failure .....	82
9.2.4	C1191: Aligning plate 2 drive failure .....	82
9.2.5	C11A0: Paper holding drive failure.....	83
9.2.6	C11A1: Exit roller pressure/retraction failure .....	83
9.2.7	C11A3: Shutter drive failure .....	84
9.2.8	C11B0: Staple unit CD drive failure .....	84
9.2.9	C11B2: Staple drive failure .....	85
9.2.10	C11C0: Punch cam motor unit failure .....	85
9.2.11	C1301: Finishing option cooling fan motor failure .....	86
9.2.12	C1402: FNS nonvolatile memory failure .....	86
9.2.13	CC155: Finisher ROM failure .....	87

FS-519/PK-515/OT-602

General

Maintenance

Adjustment / Setting

Troubleshooting

Blank Page

# General

## 1. Product specifications

### 1.1 FS-519

#### A. Type

Name	Multi staple finisher built into the copier
Installation	Installed in the copier
Document alignment	Center
Consumables	Staples

#### B. Functions

Modes	Sort, group, sort offset, group offset, sort stable, and punch (when PK-515 is mounted)
-------	---

#### C. Paper

##### (1) Non sort/sort/group

Type	Size	Weight	Max. capacity	
Plain paper Recycled paper		60 to 90 g/m <sup>2</sup> 16 to 24 lb	Exit tray1	200 sheets
			Exit tray2	A4S, 8-1/2 x 11S or less
				B4, 8-1/2 x 14 or greater
Government standard postcards	A6S, A5S/A5, B5S/B5, B6S, A4S/A4, B4, A3, A3Wide 5-1/2 x 8-1/2S/5-1/2 x 8-1/2,	91 to 210 g/m <sup>2</sup> 24.25 to 55.75 lb	20 sheets	
Envelope	8-1/2 x 11S/8-1/2 x 11, 8-1/2 x 14, 11 x 17, 12-1/4 x 18	—		
OHP transparencies		—		
Translucent paper	Max. 311.15 mm x 457.2 mm	—		
Label	12.25 x 18 inch	—		
Thick paper 1	Min. 90 mm x 139.7 mm 3.5 x 5.5 inch	91 to 150 g/m <sup>2</sup> 24.25 to 40 lb		
Thick paper 2		151 to 209 g/m <sup>2</sup> 40.25 to 55.5 lb		
Thick paper 3		210 to 256 g/m <sup>2</sup> 55.75 to 68 lb		
Thick paper 4		257 to 271 g/m <sup>2</sup> 68.25 to 72 lb		
Long size paper *	210 mm to 297 mm x 457.2 mm to 1200 mm	127 to 160 g/m <sup>2</sup> 33.75 to 42.5 lb	—	

\*: Long size paper is available only for non-sort mode.

**(2) Sort offset/group offset**

Type	Size	Weight	Max. capacity		
Plain paper Recycled paper	A5, B5S/B5, A4S/A4, B4, A3 8-1/2 x 11S/8-1/2 x 11, 8-1/2 x 14, 11 x 17 Max. 297 mm x 431.8 mm 11.75 x 17 inch Min. 182 mm x 148.5 mm	60 to 90 g/m <sup>2</sup> 16 to 24 lb	Exit tray1	200 sheets	
			Exit tray2	A4S, 8-1/2 x 11S or less	1000 sheets
Thick paper	7.25 x 5.75 inch	91 to 271 g/m <sup>2</sup> 24.25 to 72 lb		—	

**(3) Sort staple**

Type	Size	Weight	Max. capacity			No. of sheets to be stapled
Plain paper Recycled paper	A5, B5S/B5, A4S/A4, B4, A3 8-1/2 x 11S/8-1/2 x 11, 8-1/2 x 14, 11 x 17 Max. 297 mm x 431.8 mm 11.75 x 17 inch	60 to 90 g/m <sup>2</sup> 16 to 24 lb	Exit tray1	200 sheets		50 sheets*
			Exit tray2	A4S, 8-1/2 x 11S or less	1000 sheets	
Thick paper	Min. 182 mm x 148.5 mm 7.25 x 5.75 inch	91 to 120 g/m <sup>2</sup> 24.25 to 32 lb		—		
			121 to 209 g/m <sup>2</sup> 32.25 to 55.5 lb	—		15 sheets

\*: The number of sheets to be stapled is limited for high-density images.  
(Color wise: 20 sheets x 20 sets)

**(4) Punch**

Type	Size	Weight	Punched holes	Exit tray
Plain paper Recycled paper	B5S/B5 to A3 8-1/2 x 11S/8-1/2 x 11 to 11 x 17	60 to 256 g/m <sup>2</sup> 16 to 68 lb	2, 3, 4 *	Exit tray1 Exit tray2 OT-602 MT-502

\*: The punched holes is different because of the difference of area.

**D. Stapling**

Staple filling mode	Dedicated staple cartridge (5000 staples)	
Staple detection	Available (Nearly Empty: 20 remaining staples)	
Stapling position	Back of the corner (30 degree)	A4, A3, B5, B4
	Front of the corner (30 degree)	8-1/2 x 11, 11 x 17
	Back of the corner (Parallel)	A4S, B5S, A5
	Front of the corner (Parallel)	8-1/2 x 11S, 8-1/2 x 14
	Side: Parallel 2 point	A4S/A4, A3, B5S/B5, B4, A5 8-1/2 x 11S/8-1/2 x 11, 8-1/2 x 14, 11 x 17
Manual staple	None	

**E. Hole Punch**

No. of holes	Metric: 4 holes, Inch: 2 holes/3 holes, Sweden: 4 holes
Punch dust full detection	Available

**F. Machine specifications**

Power requirements	DC 24 V (supplied from the main unit)
	DC 5.1 V (generated by finisher)
Max. power consumption	66 W or less
Dimensions	352 mm (W) x 558 mm (D) x 589 mm (H) 13.75 inch (W) x 22 inch (D) x 23.25 inch (H)
	471 mm (W) x 558 mm (D) x 589 mm (H) *1 18.5 inch (W) x 22 inch (D) x 23.25 inch (H) *1
Weight	33.2 kg (73.25 lb)

\*1: Size when the paper exit tray is pulled out

**G. Operating environment**

- Conforms to the operating environment of the main body.



## 1.2 PK-515

### A. Type

Name	Punch kit PK-515	
Installation	Built into the finisher	
Paper size	Metric	B5S, A4, B4, A3
	Inch (2 holes)	8-1/2 x 11S/8-1/2 x 11, 8-1/2 x 14, 11 x 17
	Inch (3 holes)	8-1/2 x 11, 11 x 17
	Sweden	B5S, A4, B4, A3
Paper type	Plain paper (60 to 209 g/m <sup>2</sup> , 16 to 55.5 lb) Thick paper 1/2/3 (91 to 256 g/m <sup>2</sup> , 24.25 to 68 lb)	
Punch hole	Metric: 2 holes, 4 holes, Inch: 2/3 hole, Sweden: 4 holes	
Number of stored punch wastes	Metric (2 holes): For 2,500 sheets of paper (64 g/m <sup>2</sup> ) Metric (4 holes): For 1,500 sheets of paper (80 g/m <sup>2</sup> ) Inch (2/3 holes): For 1,000 sheets of paper (75 g/m <sup>2</sup> ) Sweden (4 holes): For 1,500 sheets of paper (80 g/m <sup>2</sup> )	
Document alignment	Center	

### B. Machine specifications

Power requirements	Supplied by the finisher
Dimensions	114 mm (W) x 461 mm (D) x 106 mm (H) 4.5 inch (W) x 18.25 inch (D) x 4.25 inch (H)
Weight	Approx. 1.9 kg (4.25 lb) or less

### C. Operating environment

- Conforms to the operating environment of the main body.

### 1.3 OT-602

#### A. Type

Name	Output tray OT-602
Installation	Fixed to the finisher
Mode	Sort, group, and sort stable Sort, group, sort offset, group offset, and sort stable
Number of bins	1 bin
Document alignment	Center

#### B. Paper

Mode	Size	Type	Capacity	
Sort/group	A6S, A5S/A5, B5S/B5, B6S, A4S/A4, B4, A3, A3Wide 5-1/2 x 8-1/2S/5-1/2 x 8-1/2, 8-1/2 x 11S/8-1/2 x 11, 8-1/2 x 14, 11 x 17  Max. 311.15 mm x 457.2 mm 12.25 x 18 inch  Min. 90 mm x 139.7 mm 3.5 x 5.5 inch	Plain paper	60 to 90 g/m <sup>2</sup> , 16 to 24 lb	200 sheets (up to a height of 24 mm)
		Recycled paper		
		Special	Government standard postcards	—
			Envelope	
			OHP transparencies	
			Translucent paper	
Label	—			
Thick paper	91 to 271 g/m <sup>2</sup> 24.25 to 72 lb	20 sheets		
Sort offset/ group off- set	A5, B5S/B5, A4S/A4, B4, A3 8-1/2 x 11S/8-1/2 x 11, 8-1/2 x 14, 11 x 17  Max. 297 mm x 431.8 mm 11.75 x 17 inch  Min. 182 mm x 148.5 mm 7.25 x 5.75 inch	Plain paper	60 to 90 g/m <sup>2</sup> , 16 to 24 lb	200 sheets (up to a height of 24 mm)
		Recycled paper		
		Thick paper	91 to 271 g/m <sup>2</sup> 24.25 to 72 lb	—
Sort stable	297 mm x 431.8 mm 11.75 x 17 inch  Min. 182 mm x 148.5 mm 7.25 x 5.75 inch	Plain paper	60 to 90 g/m <sup>2</sup> , 16 to 24 lb	200 sheets or 20 copies (up to a height of 24 mm)
		Recycled paper		
		Thick paper	91 to 209 g/m <sup>2</sup> 24.25 to 55.5 lb	—

**C. Machine specifications**

---

Dimensions	282 mm (W) x 368 mm (D) x 57 mm (H) 11 inch (W) x 14.5 inch (D) x 2.25 inch (H)
Weight	0.7 kg (1.5 lb)

---

**D. Operating environment**

- Conforms to the operating environment of the main body.

**NOTE**

**How product names appear in the document**

- **FS-519: Finisher**
- **PK-515: Punch kit**
- **OT-602: Output tray**

# Maintenance

## 2. Periodical check

### 2.1 Maintenance procedure (Periodical check parts)

#### NOTE

- The alcohol described in the cleaning procedure of maintenance represents the isopropyl alcohol.

#### 2.1.1 Replacing the paddles

##### A. Periodically replaced parts/cycle

- Paddles: Every 800,000 prints

##### B. Procedure

1. Remove the finisher unit.

See P.28

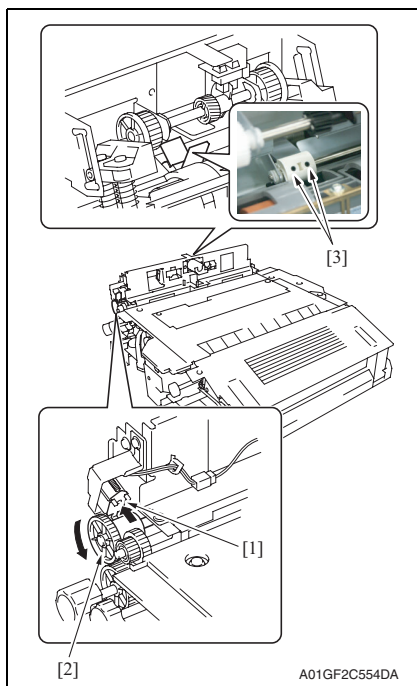

2. While pushing the plunger [1], turn the gear [2] in the direction of the arrow until two screws [3] appear as shown in the illustration.

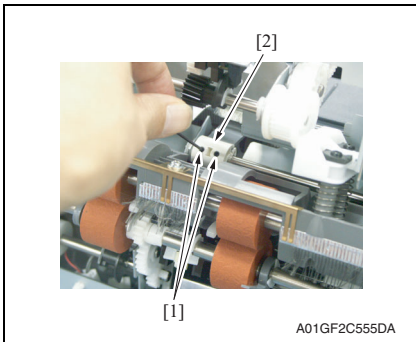

A01GF2C555DA

- Loosen two screws [1] and remove the paddle holder assy [2].

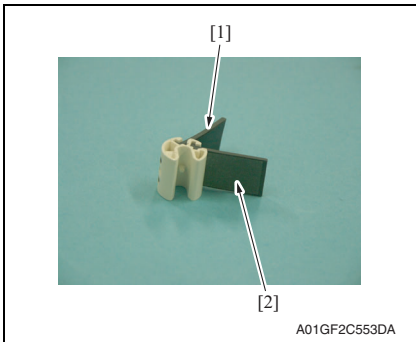

A01GF2C553DA

- Remove two paddles [1] [2] and replace them with new ones.

**NOTE**

- When installing new paddles, be sure to install the paddle covered with black film [1] and the paddle covered with transparent film [2] to their original position.
- If there is difficulty in installing the paddles, apply alcohol to the root of the paddles and install them.

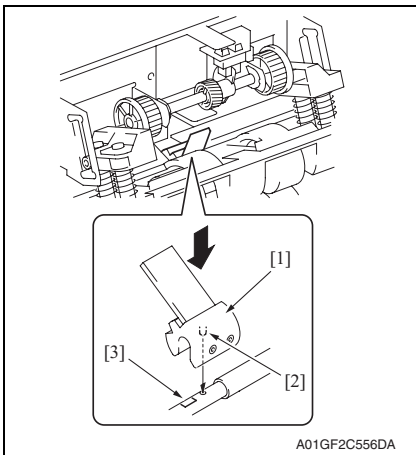

A01GF2C556DA

- Install the paddle holder assy [1].

**NOTE**

- To reinstall the paddle holder assy, place it where its locating pin [2] is aligned with the hole on the shaft. Attach the paddle holder assy onto the shaft by first pressing the assy on the side where the shaft has a depression [3].

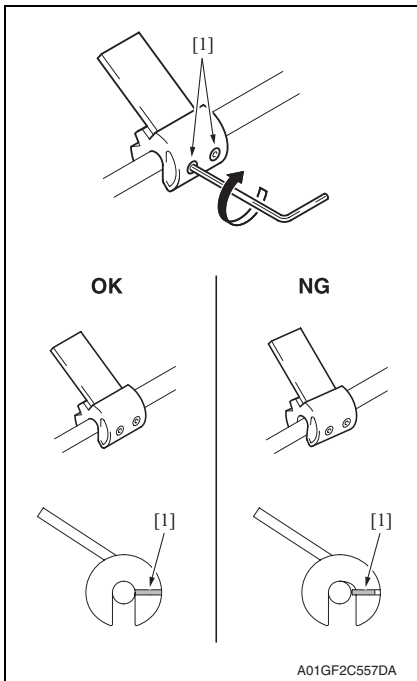

6. Secure the paddle holder assy by tightening two screws [1].

**NOTE**

- When tightening the two set screws, lightly press the paddle so that it is fixed without any tilt.
- For proper set screw tightening to fix the paddle, turn each set screw only one quarter (1/4) of a turn after the set screw tip has reached the shaft.

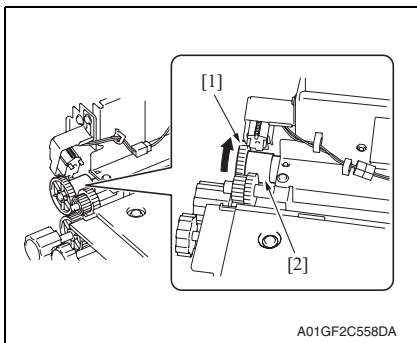

**NOTE**

- After reinstalling the paddle holder assy, check to make sure that the collar [2] remains still when you are turning the gear [1].

### 2.1.2 Replacing the cleaning pad

#### A. Periodically replaced parts/cycle

- Cleaning pad: Every 800,000 prints

#### B. Procedure

1. Remove the finisher unit.

See P.28

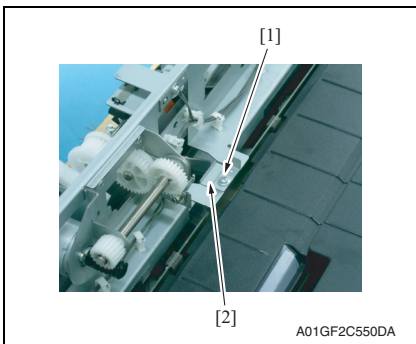

2. Remove the screw [1] and remove the cleaning pad [2].

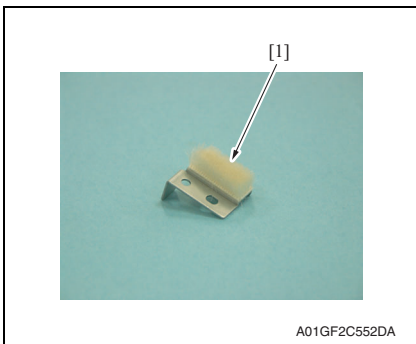

3. Peel off the cleaning pad [1].

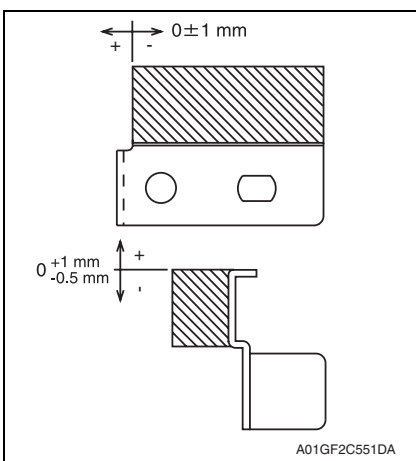

4. To reinstall, reverse the order of removal.

#### NOTE

- Before attaching a new cleaning pad, clean the metal surface where the new cleaning pad is attached.
- Align the right ends of the new cleaning pad and the metal as shown in the illustration.

**2.1.3 Lubricating the worm gear and replacing the cover film**

**A. Periodically lubricated parts/cycle**

- Worm gear: Every 800,000 prints

**B. Periodically replaced parts/cycle**

- Cover film: Every 800,000 prints

**C. Procedure**

**NOTE**

- Before the following lubrication and replacement work, make sure to remove optional SD-505 and MT-502 when the finisher is equipped with these options.

1. Turn the main and sub power switch ON. Then turn the main power switch OFF when the tray reaches the lowest position during the initial operation.
2. Remove the tray unit rear cover.

See P.23

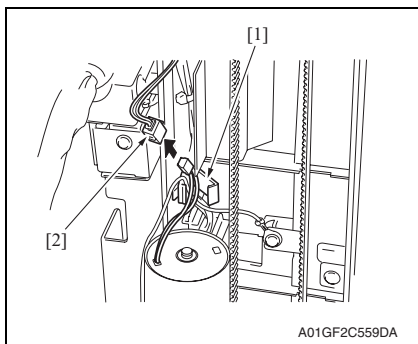

3. Remove the wire saddle [1] and disconnect the connector [2].

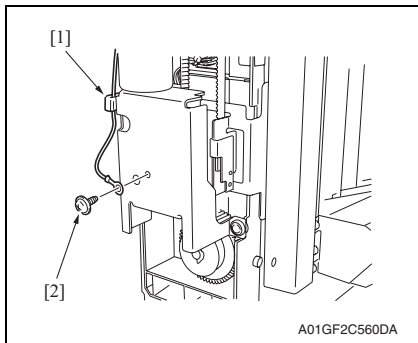

4. Remove the wire saddle [1] and the screw [2]. Remove the ground terminal.



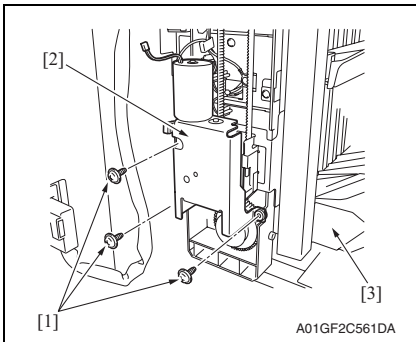

- Remove three screws [1] and remove the elevator motor assy [2].

**NOTE**

- Remove the elevator motor assy while holding the lower part of the tray [3] with your hand.

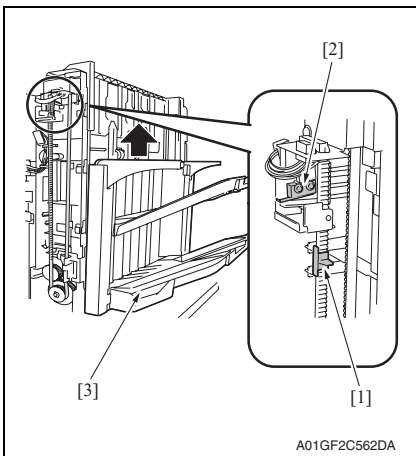

**NOTE**

- Before reinstalling the elevator motor assy, raise the tray [3] until the lever [1] attached on the timing belt moves to the position lower than that of the sensor [2]. In that state, reinstall the elevator motor assy.

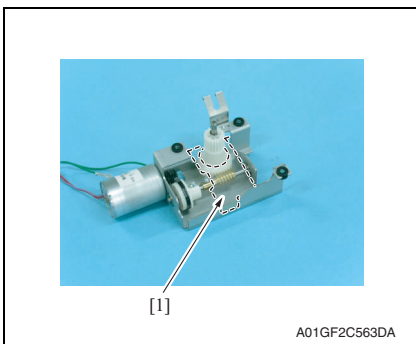

- Remove the cover film [1] by peeling off its adhesive tape.

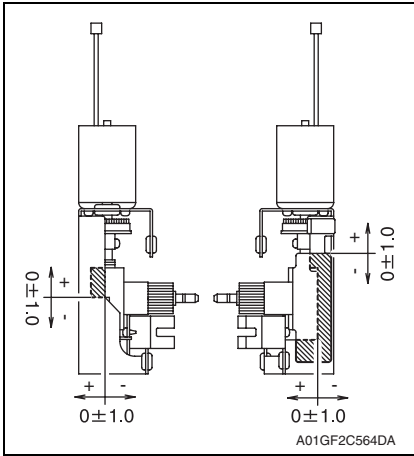

**NOTE**

- Before attaching a new cover film, clean the metal surface where the new cover film is attached.
- Align the right ends of the new cover film and the metal as shown in the illustration.

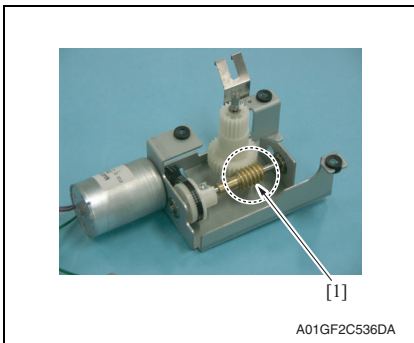

7. Apply the following grease to the worm gear [1].  
Material: Molykote EM-50L grease  
(No.: 4478 7801 ##)

8. To reinstall, reverse the order of removal.

### 2.1.4 Cleaning of the rollers and rolls

#### A. Periodically cleaning parts/cycle

- Rollers and rolls: Every 300,000 prints

#### B. Procedure

1. Remove the finisher unit.  
[See P.28](#)
2. Remove the finisher unit upper cover.  
[See P.21](#)

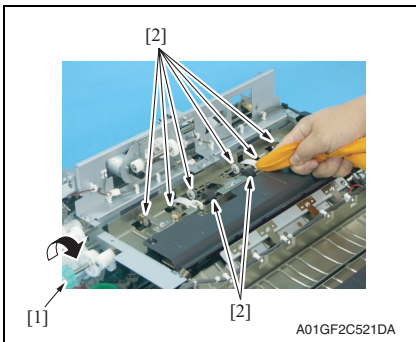

3. While turning processing knob FN5 [1], wipe the roller and roll [2] using a soft cloth dampened with alcohol.

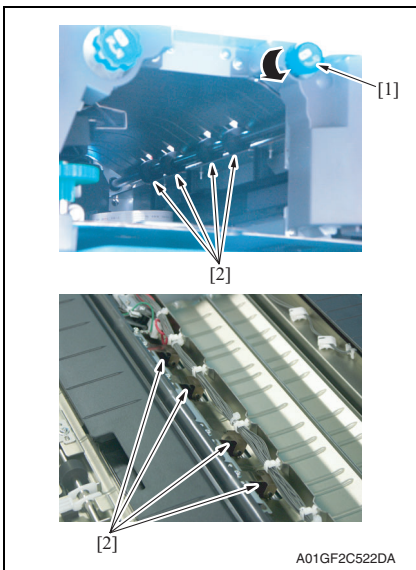

4. While turning processing knob FN4 [1], wipe the roller and roll [2] using a soft cloth dampened with alcohol.

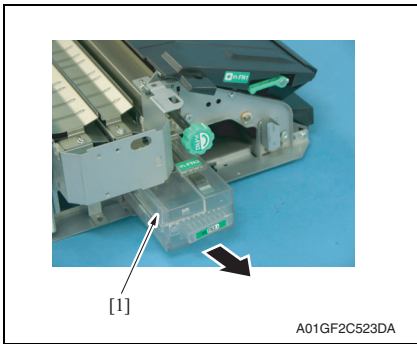

- 5. Remove punch waste storage box FN3.1 [1].  
(only when PK-515 is installed)

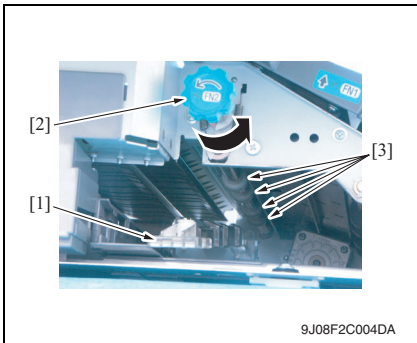

- 6. Lower processing guide FN3 [1].
- 7. While turning processing knob FN2 [2], wipe the roll [3] using a soft cloth dampened with alcohol.

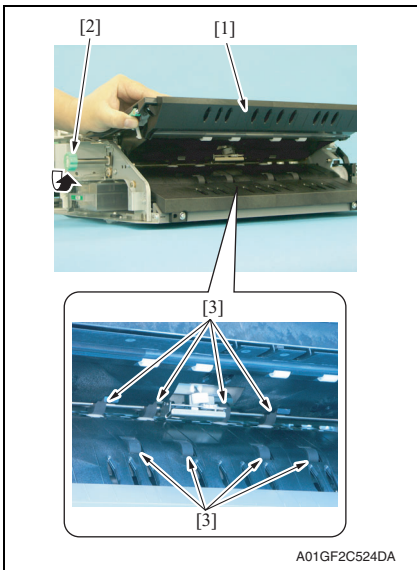

- 8. Upper processing guide FN1 [1].
- 9. While turning processing knob FN2 [2], wipe the roller [3] using a soft cloth dampened with alcohol.

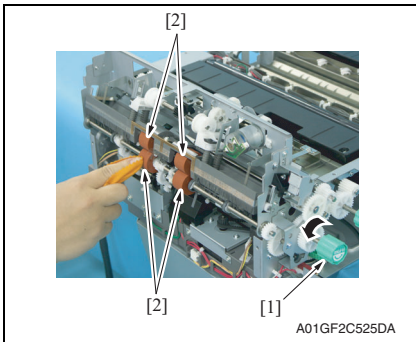

10. While turning processing knob FN6 [1], wipe the roller [2] using a soft cloth dampened with alcohol.

**2.1.5 Cleaning of the paddles**

**A. Periodically cleaning parts/cycle**

- Paddles: Every 300,000 prints

**B. Procedure**

1. Remove the finisher unit.  
[See P.28](#)

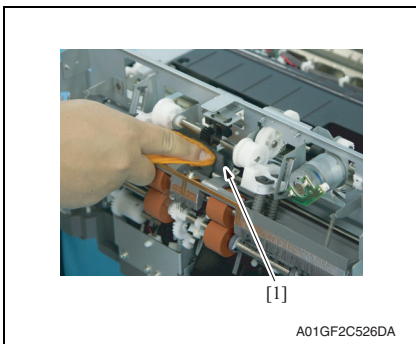

2. Using a soft cloth dampened with alcohol, wipe the paddle 1 [1].

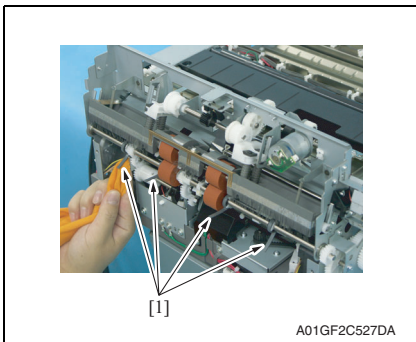

3. Using a soft cloth dampened with alcohol, wipe four paddles 2 [1].

## 3. Other

### 3.1 Disassembly/adjustment prohibited items

#### A. Paint-locked screws

##### NOTE

- To prevent loose screws, a screw lock in blue or green series color is applied to the screws.
- The screw lock is applied to the screws that may get loose due to the vibrations and loads created by the use of machine or due to the vibrations created during transportation.
- If the screw lock coated screws are loosened or removed, be sure to apply a screw lock after the screws are tightened.

#### B. Red-painted screws

##### NOTE

- The screws which are difficult to be adjusted in the field are painted in red in order to prevent them from being removed by mistake.
- Do not remove or loosen any of the red-painted screws in the field. It should also be noted that, when two or more screws are used for a single part, only one representative screw may be marked with the red paint.

#### C. Variable resistors on board

##### NOTE

- Do not turn the variable resistors on boards for which no adjusting instructions are given in Adjustment/Setting.

#### D. Removal of PWBs

##### CAUTION

- When removing a circuit board or other electrical component, refer to “Handling of PWBs” and follow the corresponding removal procedures.
- The removal procedures given in the following omit the removal of connectors and screws securing the circuit board support or circuit board.
- Where it is absolutely necessary to touch the ICs and other electrical components on the board, be sure to ground your body.

### 3.2 Precautions to be observed when option configuration is changed

- The exit tray detection position must be changed depending on configuration of the options mounted on the copier.

#### 3.2.1 Setting the exit tray detection position

##### A. When only OT-602, MT-502, or SD-505 is mounted

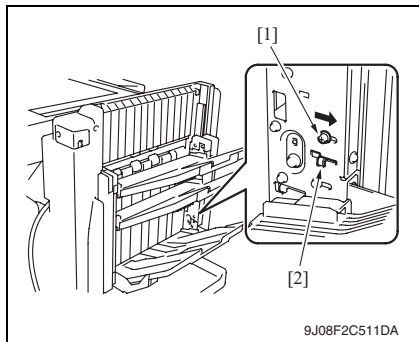

1. Loosen the screw [1] and move it in the direction of the arrow. Then, tighten it at the new position.

#### NOTE

- This step should be done securely. If not, any trouble may happen.
- Be sure to move the screw itself.
- Do not move the screw by using the adjust plate [2].

##### B. When OT-602 + MT-502 or OT-602 + SD-505 are mounted

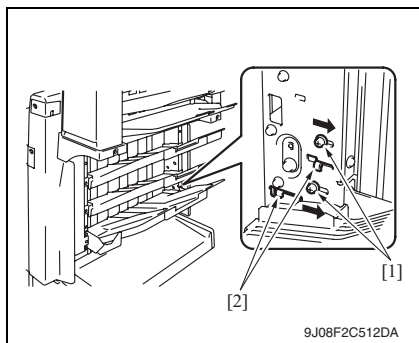

1. Loosen two screws [1] and move them in the direction of the arrow. Then, tighten them at the corresponding new positions.

#### NOTE

- This step should be done securely. If not, any trouble may happen.
- Be sure to move the screw itself.
- Do not move the screw by using the adjust plate [2].

##### C. When only FS-519 is mounted

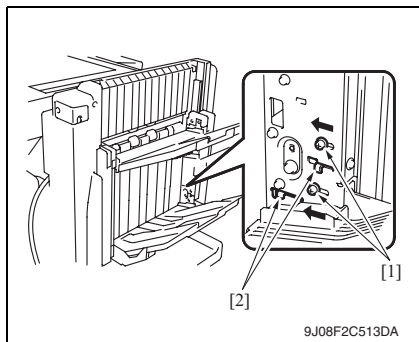

1. Loosen two screws [1] and move them in the direction of the arrow. Then, tighten them at the corresponding new positions.

#### NOTE

- This step should be done securely. If not, any trouble may happen.
- Be sure to move the screw itself.
- Do not move the screw by using the adjust plate [2].

### 3.3 Disassembly/Assembly/Cleaning list (Other parts)

#### 3.3.1 Disassembly/Assembly parts list

No.	Section	Part name	Ref. page
1	Exterior parts	Finisher unit right front cover	<a href="#">P.20</a>
2		Finisher unit left front cover	<a href="#">P.20</a>
3		Finisher unit rear cover	<a href="#">P.20</a>
4		Finisher unit upper cover	<a href="#">P.21</a>
5		Front door	<a href="#">P.21</a>
6		Middle guide	<a href="#">P.22</a>
7		Intake cover	<a href="#">P.23</a>
8		Tray unit front cover	<a href="#">P.23</a>
9		Tray unit rear cover	<a href="#">P.23</a>
10		Connector cover	<a href="#">P.23</a>
11		Tray 1	<a href="#">P.24</a>
12		Tray 2	<a href="#">P.24</a>
13		Output tray OT-602 (Option)	<a href="#">P.24</a>
14	Units	Tray unit	<a href="#">P.25</a>
15		Finisher unit	<a href="#">P.28</a>
16		Stapler unit	<a href="#">P.36</a>
17		Punch kit PK-515 (Option)	<a href="#">P.37</a>
18	Electric parts	Exit roller motor	<a href="#">P.38</a>
19		Elevator motor	<a href="#">P.49</a>
20		Duplex guide solenoid	<a href="#">P.56</a>
21		FS control board	<a href="#">P.58</a>
22	Others	Storage paddle drive clutch	<a href="#">P.38</a>
23		Exit upper roller	<a href="#">P.38</a>
24		Storage paddle	<a href="#">P.38</a>
25		Exit paddle drive clutch	<a href="#">P.43</a>
26		Exit lower roller	<a href="#">P.43</a>
27		Aligning section	<a href="#">P.46</a>
28		Timing belt	<a href="#">P.49</a>
29		Shutter drive gear	<a href="#">P.55</a>



### 3.4 Disassembly/Assembly procedure

#### 3.4.1 Finisher unit right front cover

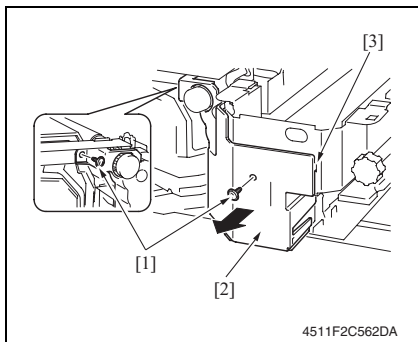

1. Open the front door.
2. Remove two screws [1] and remove the finisher unit right front cover [2].

#### NOTE

- At reinstallation, first fit the tab [3] into position.

#### 3.4.2 Finisher unit left front cover

1. Remove the front door.  
See P.21

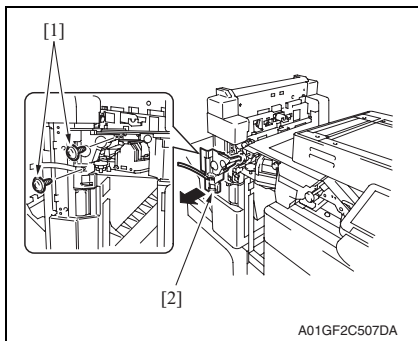

2. Remove two screws [1] and remove the finisher unit left front cover [2].

#### 3.4.3 Finisher unit rear cover

1. Remove the finisher unit.  
See P.28

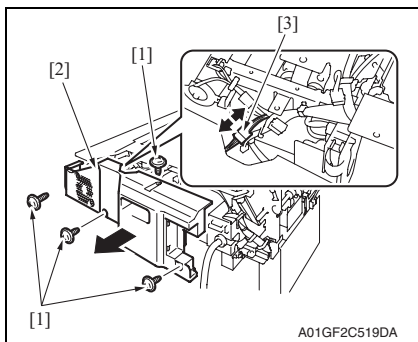

2. Remove four screws [1] and remove the finisher unit rear cover [2].
3. Disconnect the connector [3].

### 3.4.4 Finisher unit upper cover

1. Remove the finisher unit.  
See P.28
2. Remove the finisher unit rear cover.  
See P.20

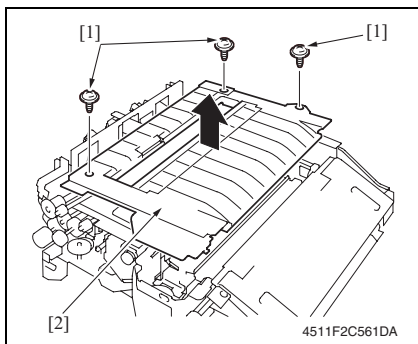

3. Remove three screws [1] and remove the finisher unit upper cover [2].

### 3.4.5 Front door

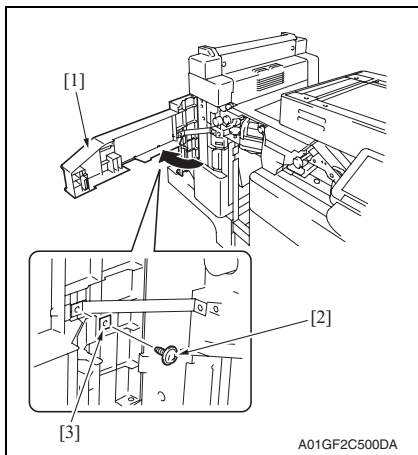

1. Open the front door [1].
2. Remove the screw [2] and the retaining plate [3].

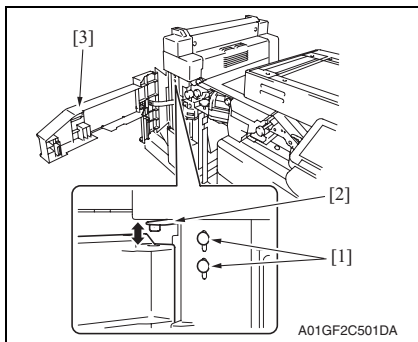

3. Loosen two screws [1] and move the hinge [2] up. Then remove the front door [3].

### 3.4.6 Middle guide

1. Remove the finisher unit.  
[See P.28](#)
2. Remove the finisher unit rear cover.  
[See P.20](#)
3. Remove the finisher unit upper cover.  
[See P.21](#)

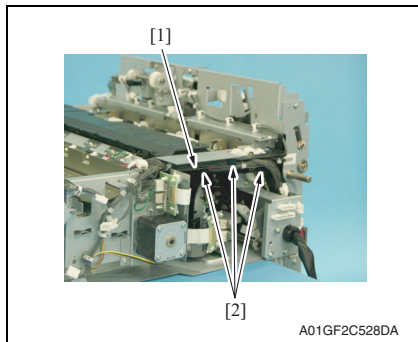

4. Remove the harness bundle [1] from three harness guides [2].

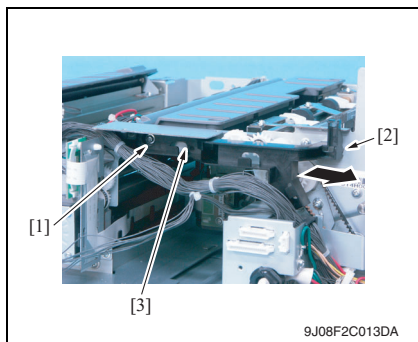

5. Remove the screw [1] and tab [2], and remove the harness guide [3].

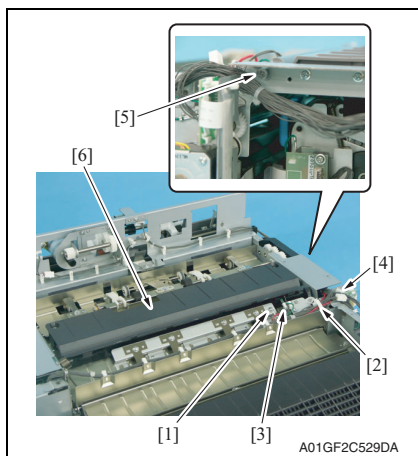

6. Remove the screw [1] and the ground wire.
7. Remove the wire saddle [2] and edge cover [3], and disconnect the connector [4].
8. Remove the shoulder screw [5] and remove the middle guide [6].

### 3.4.7 Intake cover

1. Remove the finisher unit.  
See P.28
2. Remove the finisher unit rear cover.  
See P.20
3. Remove the finisher unit upper cover.  
See P.21

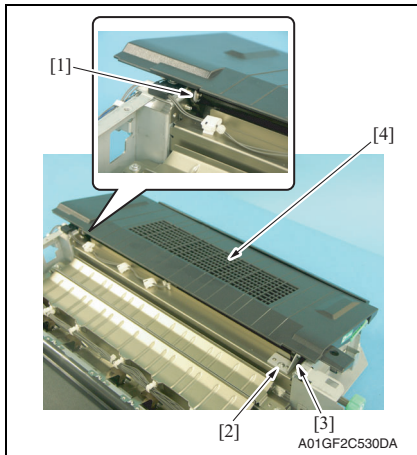

4. Remove the C-ring [1].
5. Remove the screw [2] and the metal bracket [3], and the intake cover [4].

### 3.4.8 Tray unit front cover/Tray unit rear cover/Connector cover

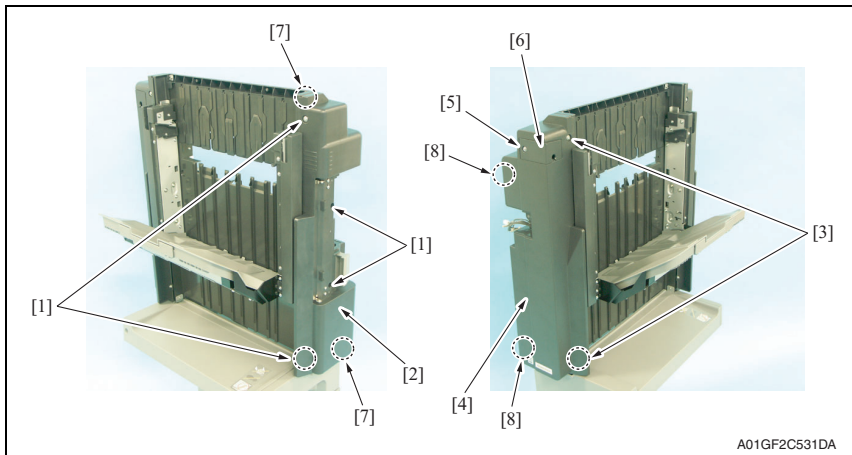

1. Remove four screws [1] and remove the tray unit front cover [2].
2. Remove two screws [3] and remove the tray unit rear cover [4].
3. Remove the screw [5] and remove the connector cover [6].

**NOTE**

- When installing the tray unit front cover, snap two tabs [7] first.
- When installing the tray unit back cover, snap two tabs [8] first.

### 3.4.9 Tray 1/Tray 2

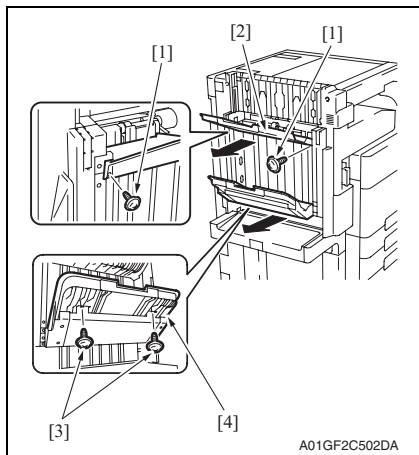

1. Remove two screws [1], and remove the tray 1 [2].
2. Remove two screws [3], and remove the tray 2 [4].

### 3.4.10 Output tray (OT-602): Option

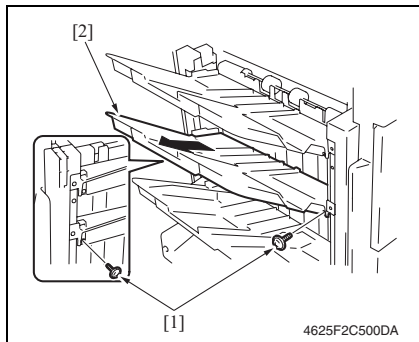

1. Remove two screws [1], and remove the output tray [2].

### 3.4.11 Tray unit

#### NOTE

- When removing the tray unit, set the tray unit to its home position.
- If the exit tray (OT-602) is installed, remove it in advance.

See P.24

1. Remove the front door.

See P.21

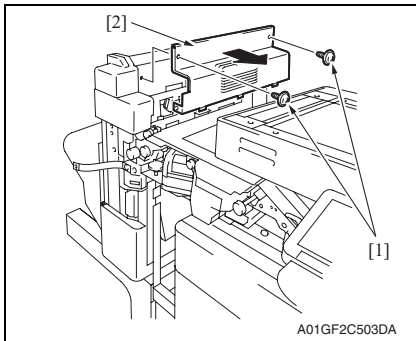

2. Remove two screws [1] and remove the tray unit upper cover [2].

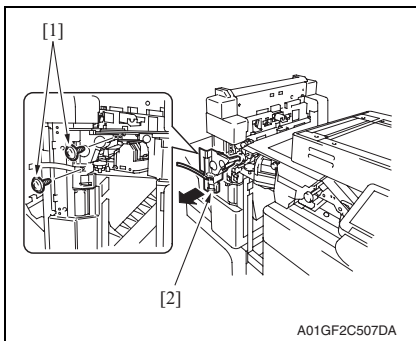

3. Remove two screws [1] and remove the finisher unit left front cover [2].

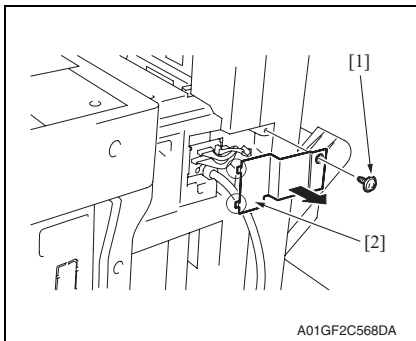

4. Remove the screw [1] and remove the connector cover [2].

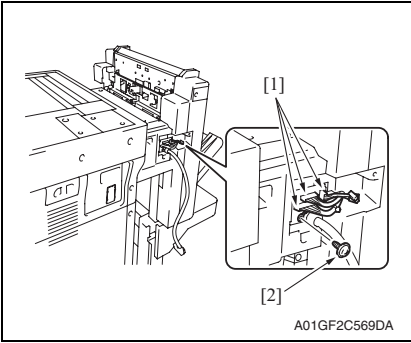

5. Disconnect three connectors [1] and remove the screw [2], and the ground wire.

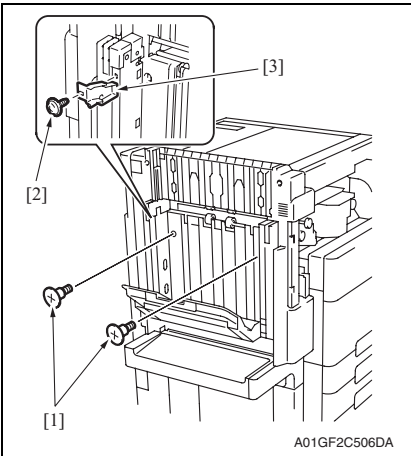

6. Remove two shoulder screws [1].

**NOTE**

- When the output tray (OT-602) is mounted, remove the screw [2] and remove the mounting holder [3].

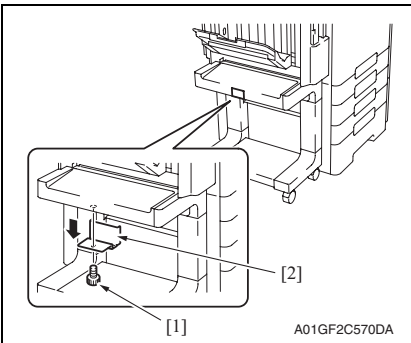

7. Remove the screw [1] and the stopper [2] shown in the illustration.

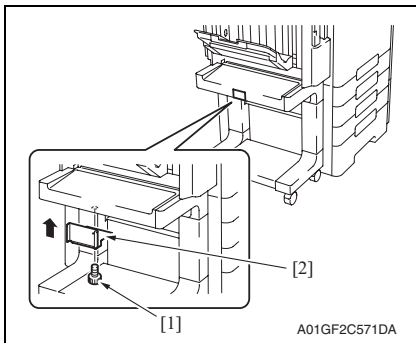

8. Position the stopper [2] as shown and secure it with the screw [1].

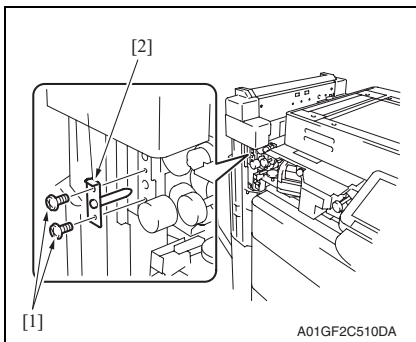

9. Remove two screws [1] and remove the mounting bracket [2].

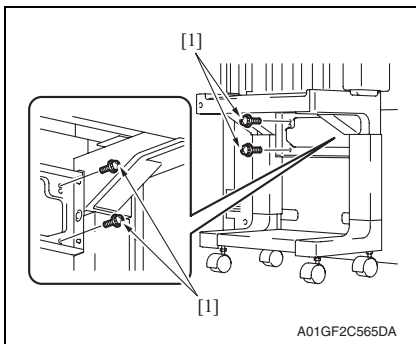

10. Remove four screws [1].



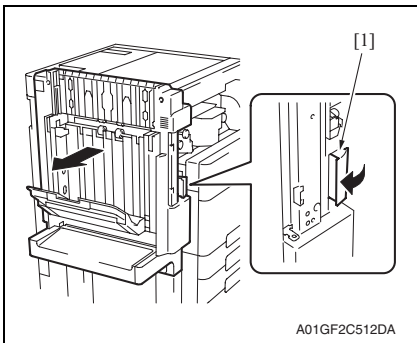

11. Pull the lock release lever [1] and remove the tray unit.

**NOTE**

- **Make sure the height and angle adjustment of stand table when installing the finisher.**

[See P.34](#)

**3.4.12 Finisher unit**

1. Remove the tray unit.

[See P.25](#)

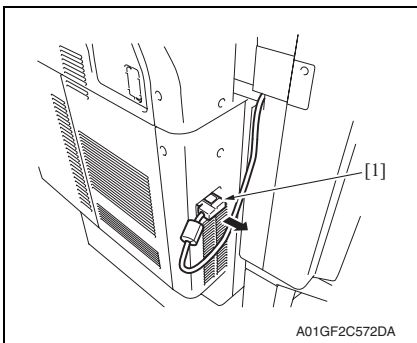

2. Disconnect the hookup cord [1].

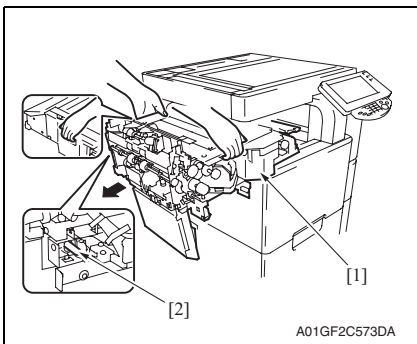

3. Hold the positions as shown in the illustration to remove the finisher unit [1].

**NOTE**

- **When setting the finisher unit, make sure to fit the finisher unit hole with stabilizing pin [2] and set it to the end.**
- **Make sure the height and angle adjustment of stand table when installing the finisher.**

[See P.34](#)

### 3.4.13 Changing the height of the stand table

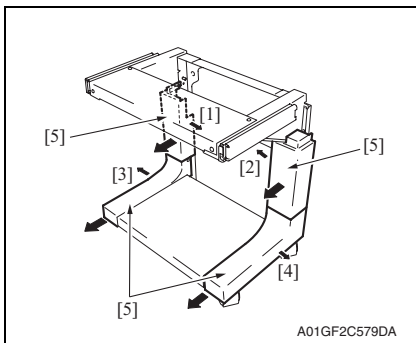

1. Remove four covers [5] while removing four latches [1], [2], [3], and [4].

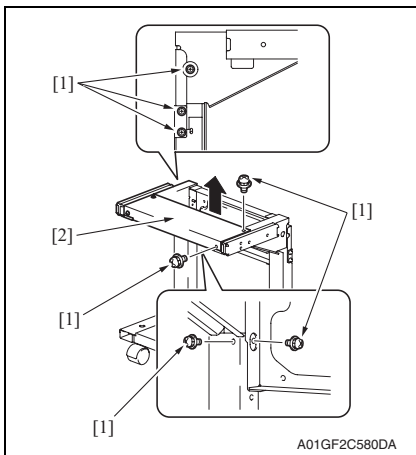

2. Remove seven screws [1] to remove the upper unit (rear) for the stand table [2].

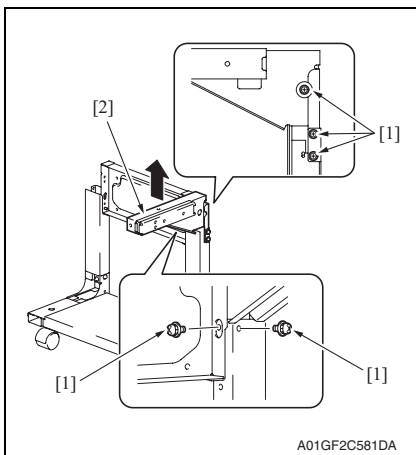

3. Remove five screws [1] to remove the upper unit (front) for the stand table [2].

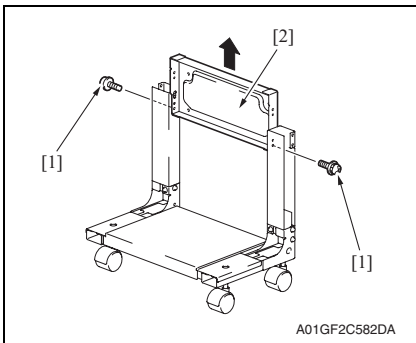

4. Remove two screws [1] to remove the mounting plate [2].

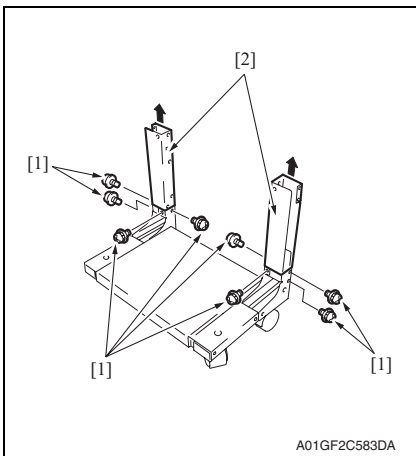

5. Remove eight screws [1] to remove two supports [2].

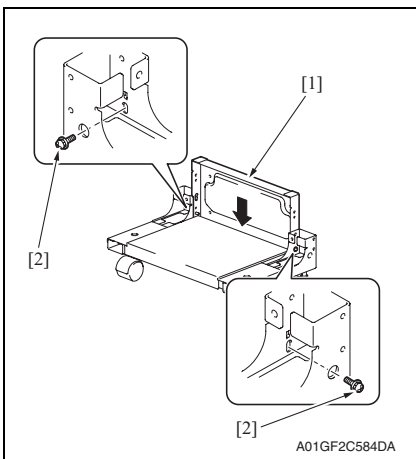

6. Set the mounting plate [1] which was removed in step 4, and tighten two screws [2].

**NOTE**

- Use care since the length of these screws are different from other screws.

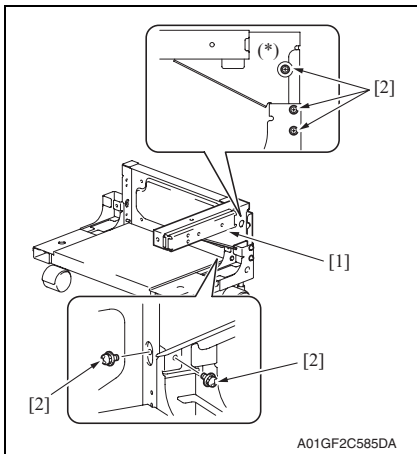

7. Mount the stand table upper unit (front) [1] which was removed in step 3, and tighten five screws [2].

**NOTE**

- Use care since the lengths of the screws (\*) shown on the illustration are different from other screws.

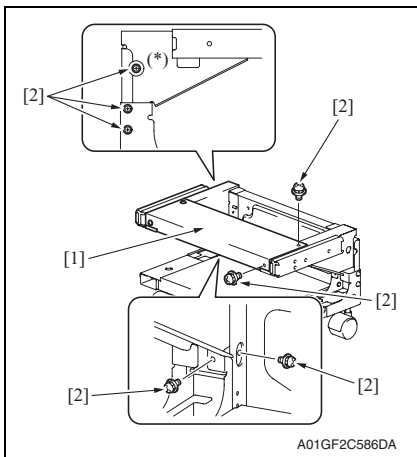

8. Mount the stand table upper unit (rear) [1] which was removed in step 2, and tighten seven screws [2].

**NOTE**

- Use care since the lengths of the screws (\*) shown on the illustration are different from other screws.

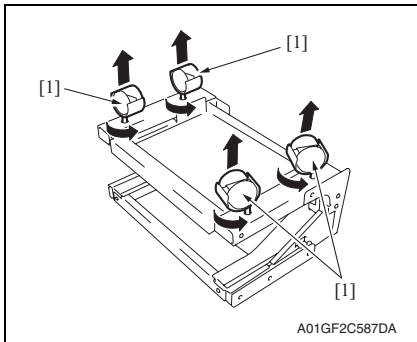

9. Place the stand table upside-down, and remove four casters [1].

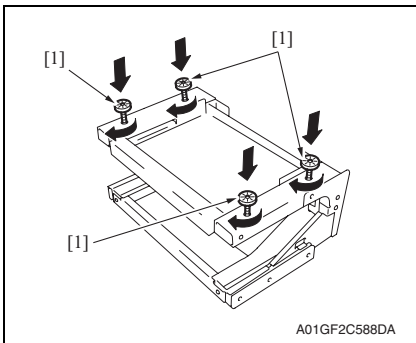

10. Mount four adjusting plates [1] furnished with the main body.

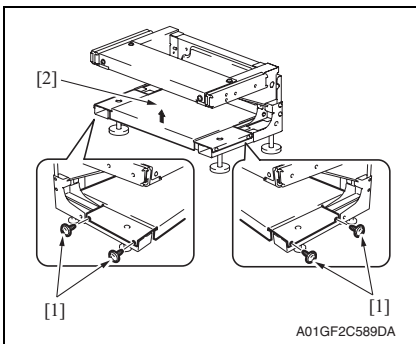

11. Remove four screws [1] and remove the lower unit for the stand table [2].

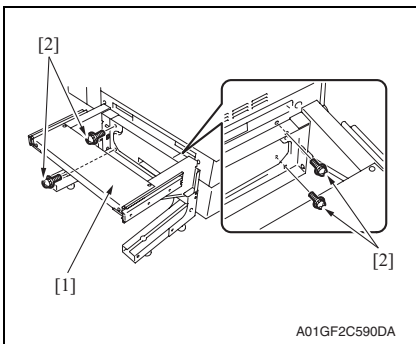

12. Mount the stand table [1] to the main body, and tighten it with four screws [2].

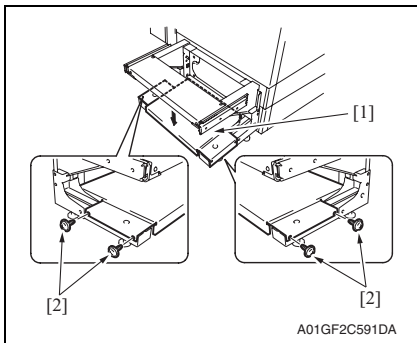

13. Mount the lower unit for the stand table [1] which was removed in step 11, and tighten four screws [2].

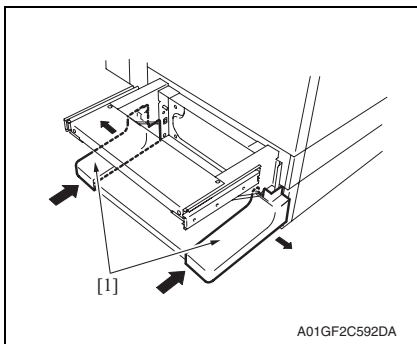

14. Mount two covers [1] which were removed in step 1.

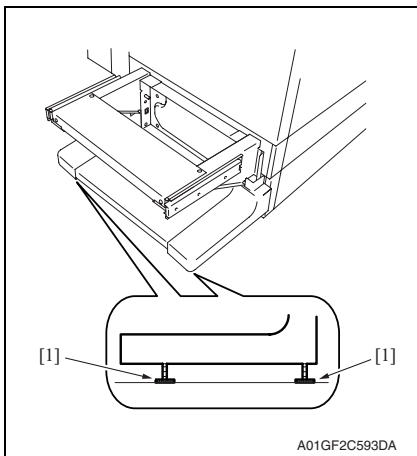

15. Adjust the adjusting plate [1] to touches the floor.

**NOTE**

- **When the height of the setting table is changed, check for the tilt of the setting table.**

[See P.34](#)

### 3.4.14 Height and angle adjustment of stand table

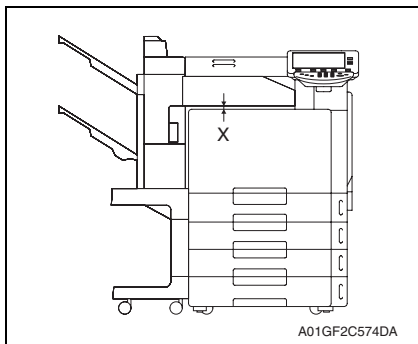

1. Measure the width of X on front and back side.  
Specifications:  $5 \pm 2$  mm
2. Following adjustment is necessary when the width does not fall within the specifications.

3. Pull the lever to unlock it, and remove the tray unit from the main body.

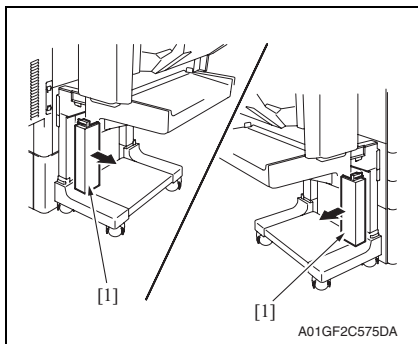

4. Remove two covers [1] from the legs of the stand table.

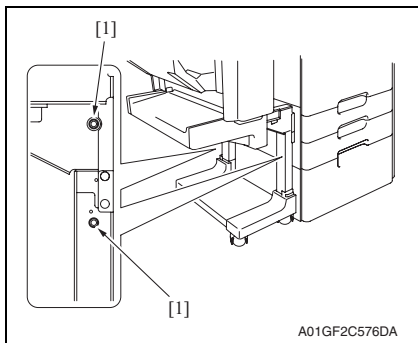

5. Loosen four screws [1] (two screws each for the left and right) and adjust the height of the stand. Tighten the screws again.

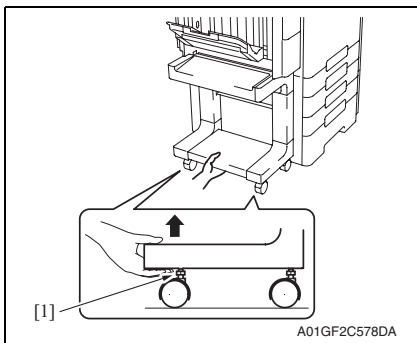
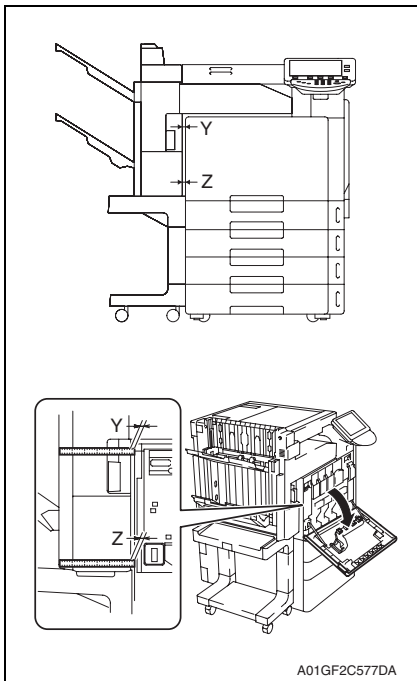

- 6. Measure the width of Y and Z (clearance of the exterior parts) on front and back side.

Specifications:

$$Y = Z - 1 \text{ mm}$$

(Y must be smaller than Z)

$$Z = 7 \pm 2 \text{ mm (front side)}$$

$$Z = 9 \pm 2 \text{ mm (back side)}$$

**NOTE**

- To measure the front side, open the front door and measure it using finisher side as supporting point referring showed on the illustration left.

- 7. When the value does not fall within the specified range, remove the tray unit and pull up the casters to adjust them.

**NOTE**

- For adjusting the casters, hold the bottom part of the stand table and turn the adjusting bolt [1].



### 3.4.15 Stapler unit

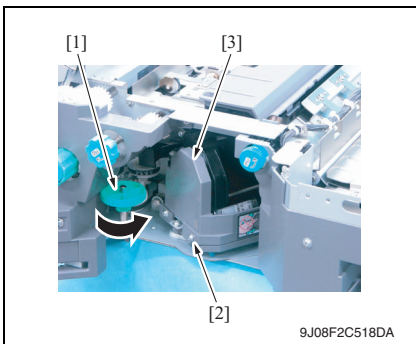

1. Open the front door.
2. Turn the dial [1], and move the stapler forward.
3. Remove the staple cartridge.
4. Remove the screw [2], and remove the cover [3].

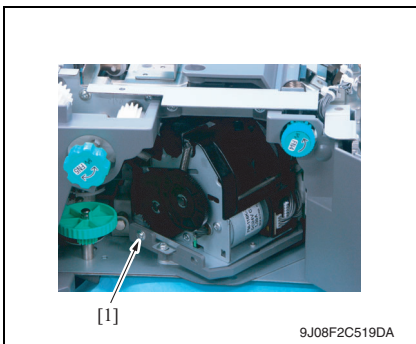

5. Remove the screw [1].

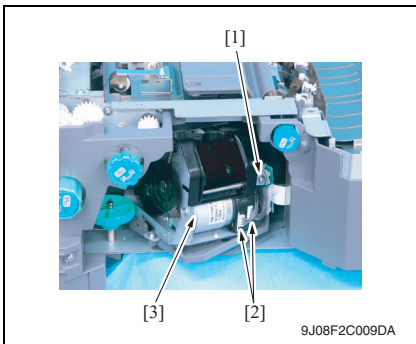

6. Remove the screw [1] and remove the ground wire.
7. Disconnect two connectors [2] and remove the stapler unit [3].

### 3.4.16 Punch kit (PK-515): Option

1. Remove the finisher unit.  
See P.28
2. Remove the finisher unit rear cover.  
See P.20
3. Remove the finisher unit upper cover.  
See P.21
4. Remove the finisher unit right front cover.  
See P.20

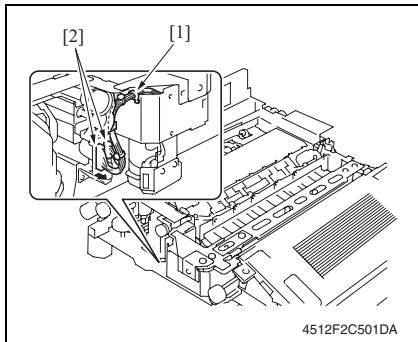

5. Remove the edge cover [1] and disconnect two connectors [2].

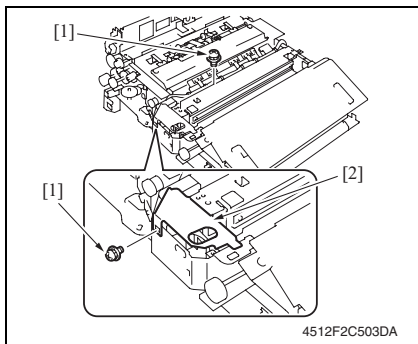

#### NOTE

- When the creasing unit is mounted, remove two screws [1], and remove the metal bracket [2].

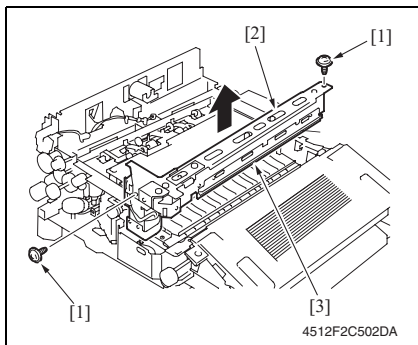

6. Remove two screws [1] and remove the punch kit [2].

#### NOTE

- Take care so that the mylar [3] will not be bent.

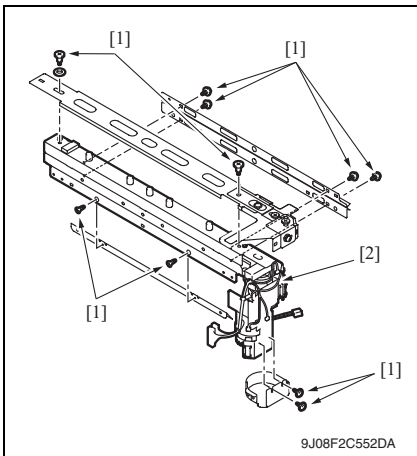

7. Remove ten screws [1] and remove the punch kit [2].

**3.4.17 Exit roller motor/Storage paddle drive clutch/Exit upper roller/Storage paddle**

1. Remove the finisher unit.  
See P.28
2. Remove the finisher unit left front cover.  
See P.20

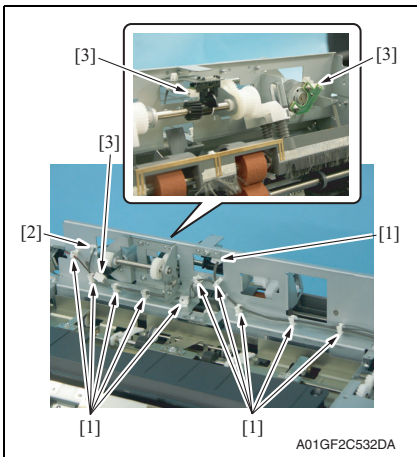

3. Remove eleven wire saddles [1] and remove the edge cover [2].
4. Disconnect three connectors [3].

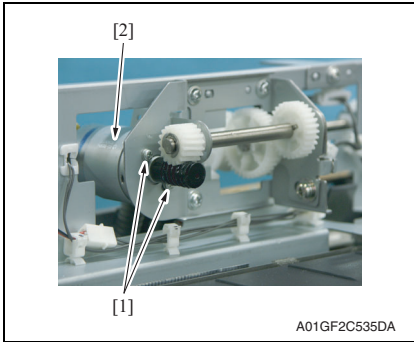

- 5. Remove two screws [1] and remove the exit roller motor [2].

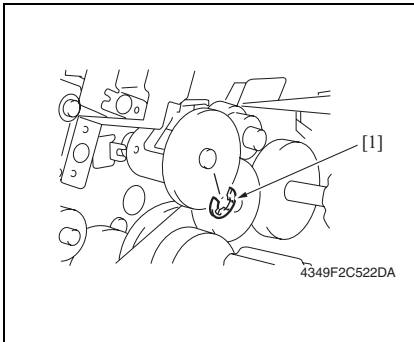

- 6. Remove the E-ring [1].

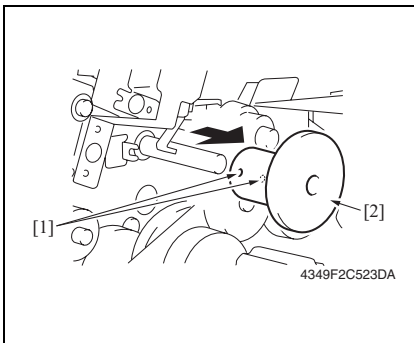

- 7. Loosen two hexagonal socket head screws [1], and remove the storage paddle drive clutch assy [2].

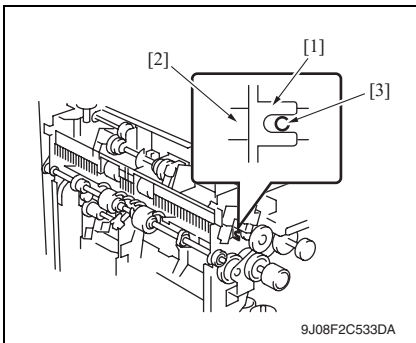

**NOTE**

- When installing the storage paddle drive clutch, insert the hexagonal wrench into the flame notch [1], and confirm that the storage paddle drive axis [2] fits to the 2 mm-hole [3].

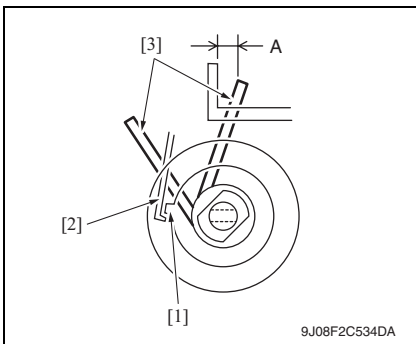

**NOTE**

- When installing the storage paddle drive clutch, hook the solenoid flapper [2] on the tab [1] and confirm two storage paddles [3] locates the position as shown in the illustration.  
Specifications A:  $3.3 \pm 3$  mm

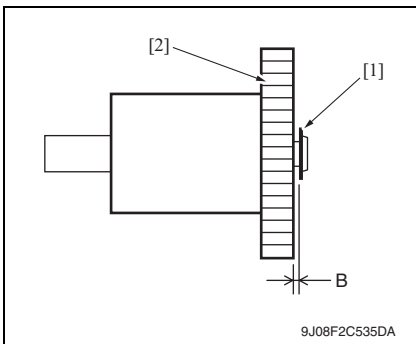

**NOTE**

- When installing the storage paddle drive clutch, adjust the distance between the E-ring [1] and the storage paddle drive clutch gear [2].  
Specifications B:  $0.2 \pm 0.1$  mm

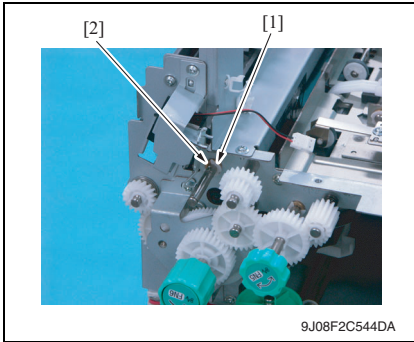

8. Remove the C-ring [1] and the bushing [2].

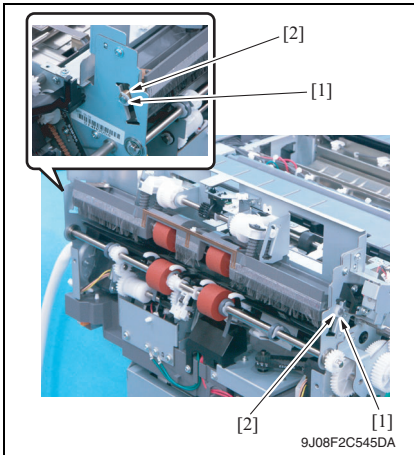

9. Remove two C-rings [1] and two bushings [2].

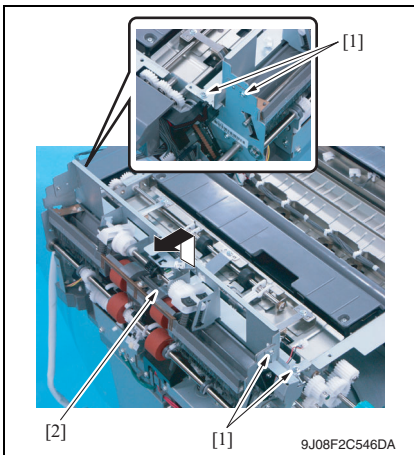

10. Remove four screws [1] and remove the exit transportation section (upper) assy [2].

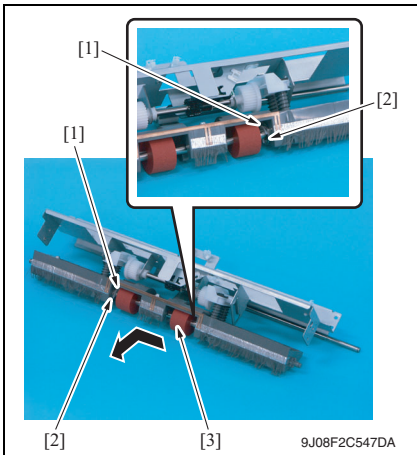

11. Remove two C-rings [1] and two bearings [2], and remove the exit upper roller assy [3].

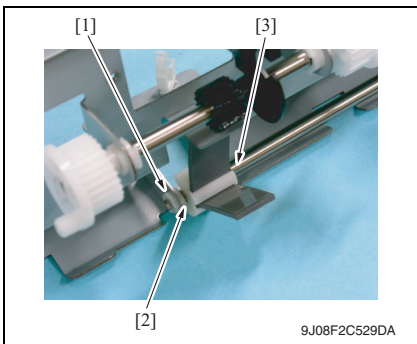

12. Remove the C-ring [1] and the bushing [2], and remove the storage paddle assy [3].

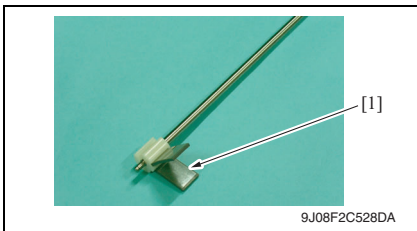

13. Remove the storage paddle [1].

14. Disassemble the pressure/retraction system units

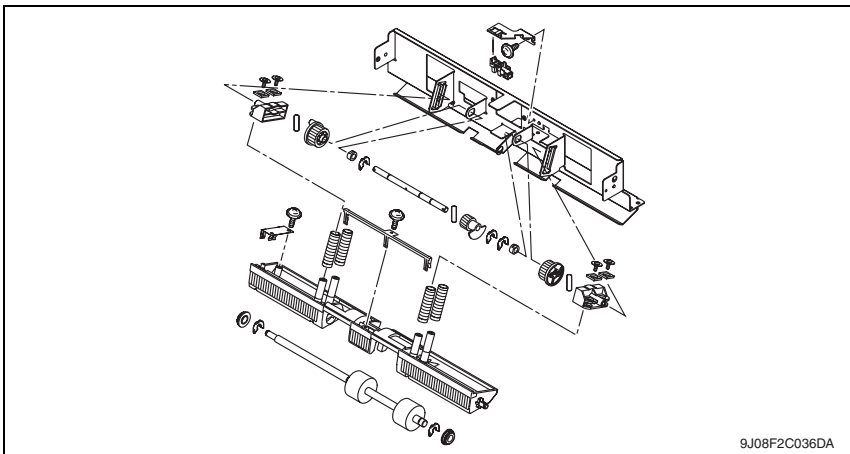

3.4.18 Exit paddle drive clutch/Exit lower roller

1. Remove the finisher unit.  
[See P.28](#)
2. Remove the finisher unit left front cover.  
[See P.20](#)

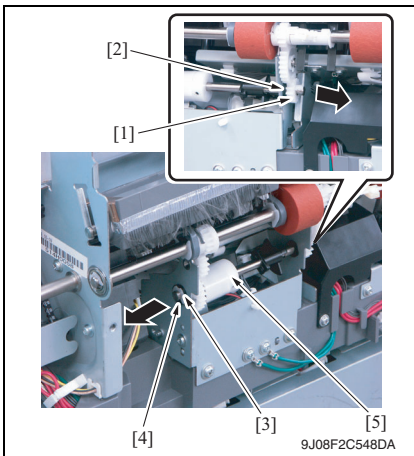

3. Remove the gear [1] and the bushing [2].
4. Remove the C-ring [3] and the bushing [4].
5. Remove the exit paddle drive clutch assy [5].



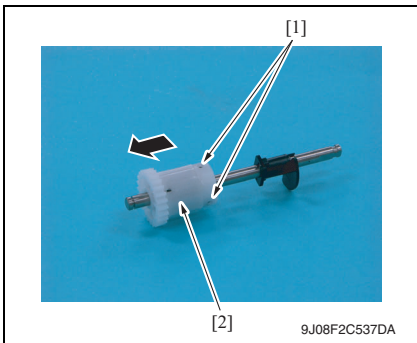

6. Loosen two hexagonal socket head screws [1], and remove the exit paddle drive clutch assy [2].

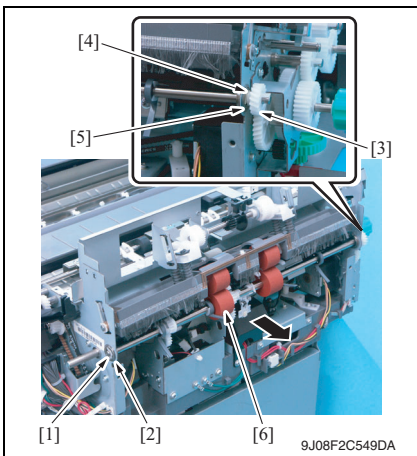

7. Remove the C-ring [1] and the bearing [2].
8. Remove the gear [3], C-ring [4] and bearing [5].
9. Remove the exit lower roller assy [6].

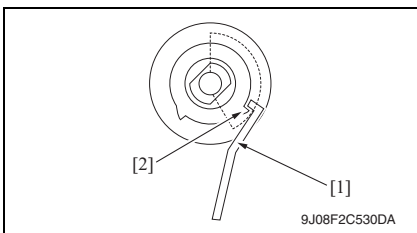

**NOTE**

- When installing the exit paddle drive clutch, turn up the side that the distance between tabs is wider and hook the solenoid flapper [1] on the tab [2].

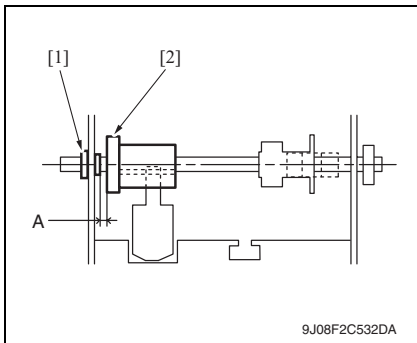

**NOTE**

- When installing the exit paddle drive clutch assy, adjust the distance between the bushing [1] and the exit paddle drive clutch [2] to 0.2 mm and tighten two hexagonal socket head screws.

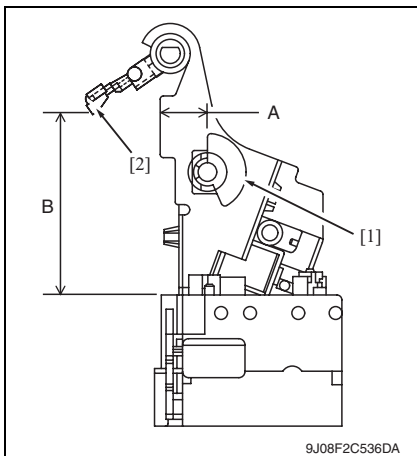

**NOTE**

- When installing the exit paddle drive clutch assy, adjust the position of blocked panel [1].  
Specifications A:  $14.6 \pm 1$  mm
- When installing the exit lower roller assy, adjust the position of the arm holder [2].  
Specifications B:  $56.4 \pm 3$  mm

**10. Disassemble the exit lower roller assy**

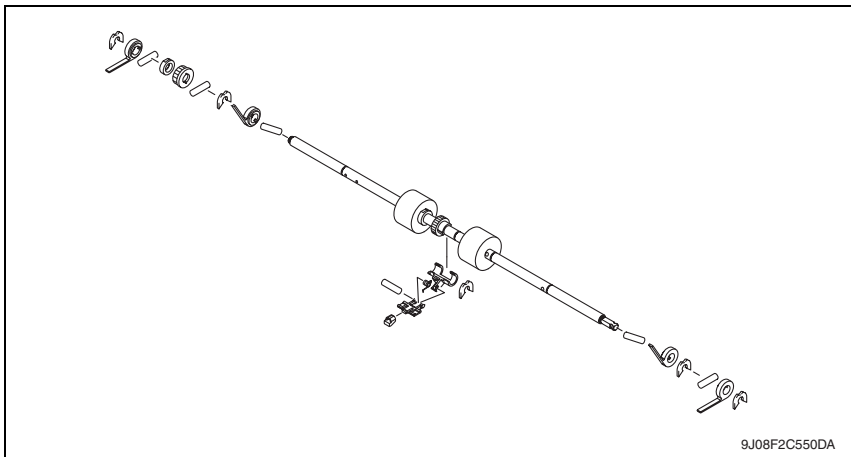

### 3.4.19 Aligning section

1. Remove the finisher unit left front cover.  
[See P.20](#)
2. Remove the finisher unit rear cover.  
[See P.20](#)
3. Remove the finisher unit upper cover.  
[See P.21](#)
4. Remove the exit transportation section (upper) assy.  
[See P.38](#)
5. Remove the exit lower roller assy.  
[See P.43](#)

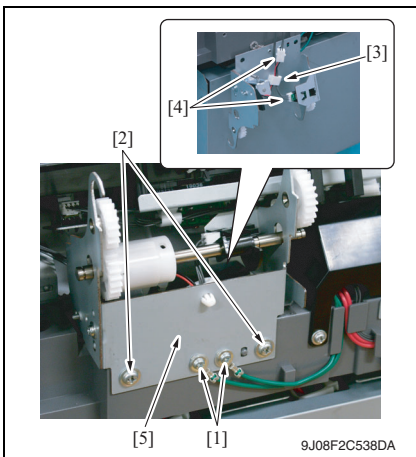

6. Remove two screws [1] and remove the ground wire.
7. Remove two screws [2].
8. Remove the wire saddle [3] and disconnect two connectors [4], and remove the exit paddle drive clutch mounting plate assy [5].

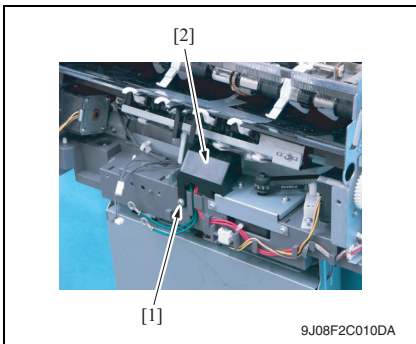

9. Remove the screw [1] and remove the connector cover [2].

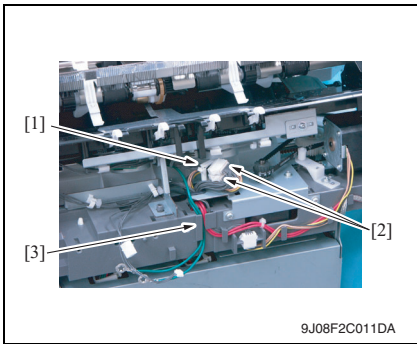

- 10. Remove the wire saddle [1] and disconnect two connectors [2].
- 11. Remove the ground wire from the harness guide [3].

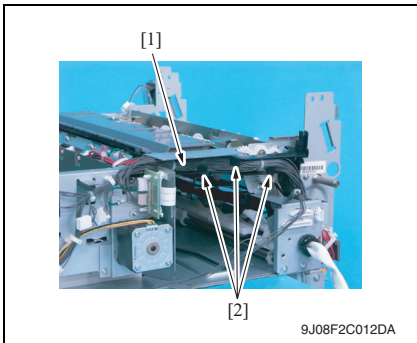

- 12. Remove the harness bundle [1] from the harness guide [2].

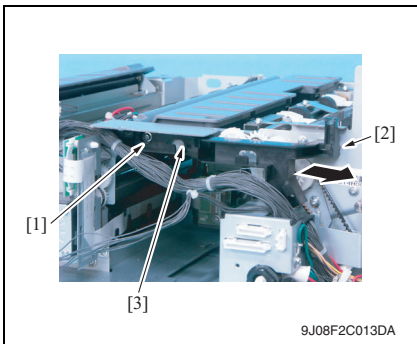

- 13. Remove the screw [1] and tab [2], and remove the harness guide [3].

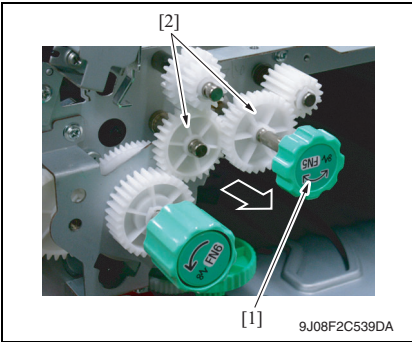

14. Remove the knob [1] of FN5 and remove two gears [2].

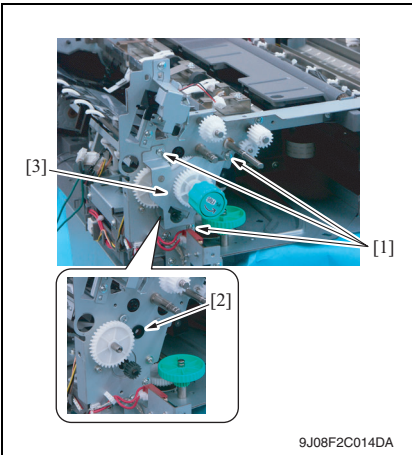

15. Remove three screws [1] and bushing [2], and remove the gear assy [3].

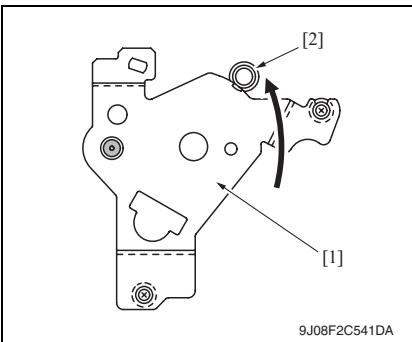

**NOTE**

- When installing the gear assy, fit the mounting plate [1] to the caulk-ing axis [2], and tightening with screw.
- Make sure that the gear rotates smoothly.

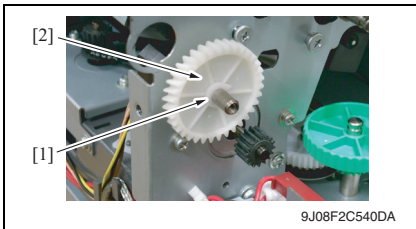

16. Remove the C-ring [1] and remove the gear [2].

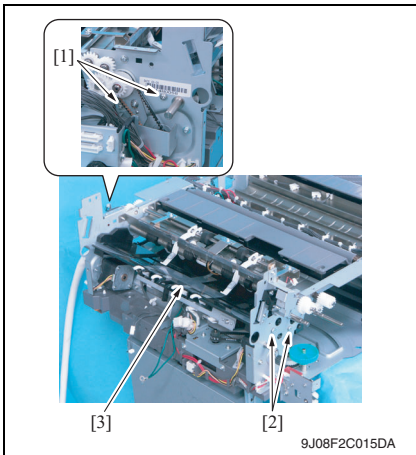

17. Remove two screws [1] and two shoulder screws [2], and remove the aligning plate assy [3].

### 3.4.20 Elevator motor/Timing belt

#### A. Removal procedure

1. Remove the tray unit.  
[See P.25](#)
2. Remove the tray unit front cover.  
[See P.23](#)
3. Remove the tray unit rear cover.  
[See P.23](#)

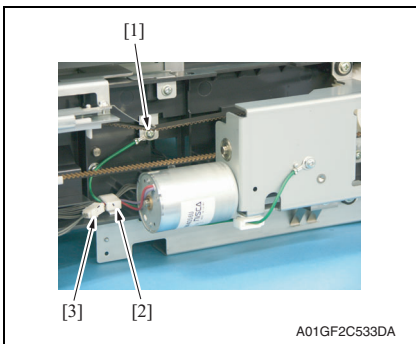

4. Remove the screw [1] and remove the ground wire.
5. Remove the wire saddle [2] and disconnect the connector [3].

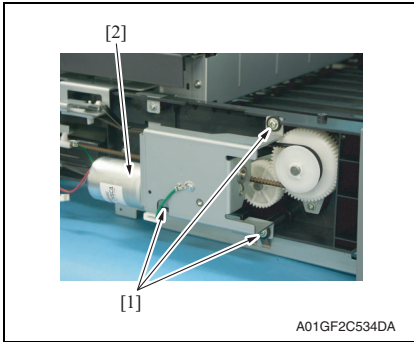

- 6. Remove three screws [1] and remove the elevator motor assy [2].

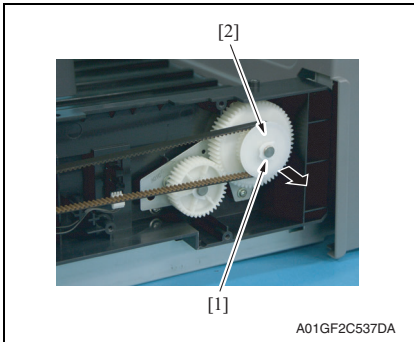

- 7. Remove the C-ring [1] and remove the gear cover [2].

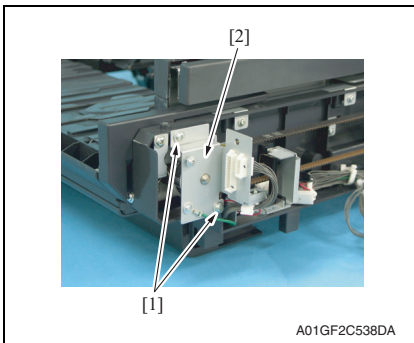

- 8. Remove two screws [1] and remove the metal bracket [2].

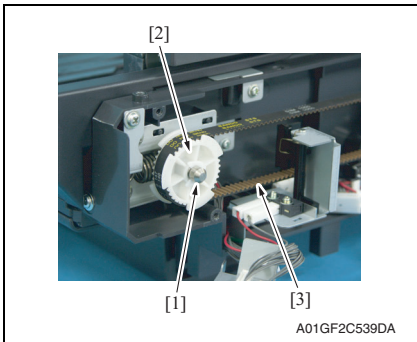

9. Remove the C-ring [1] and remove the gear (upper rear) [2] and belt [3].

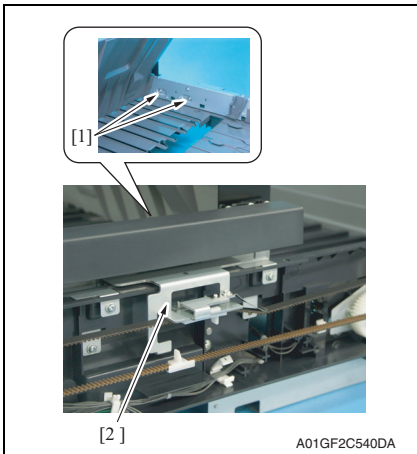

10. Remove two screws [1] and remove elevator mounting plate (rear) [2].

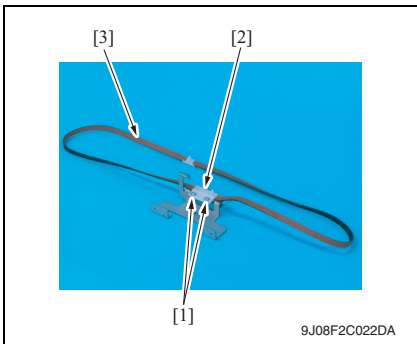

11. Remove two screws [1] and remove the belt holder [2].

12. Remove the timing belt (rear) [3].

**NOTE**

- **When installing the timing belt, make sure there is no looseness.**



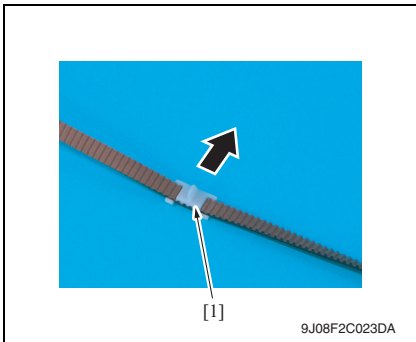

9J08F2C023DA

13. Remove the lever [1].

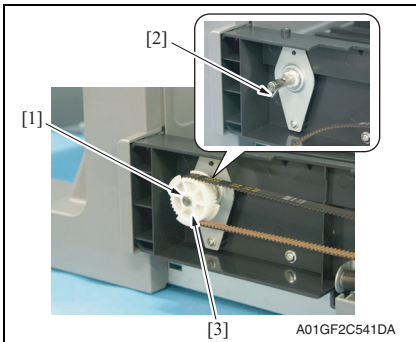

A01GF2C541DA

14. Remove the C-ring [1] and pin [2], and remove the gear (lower front) [3].

**NOTE**

- Use care not to lose the pin.

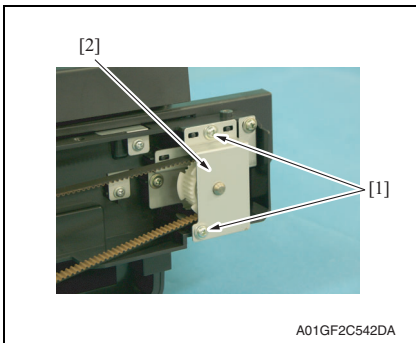

A01GF2C542DA

15. Remove two screws [1] and remove the metal bracket [2].

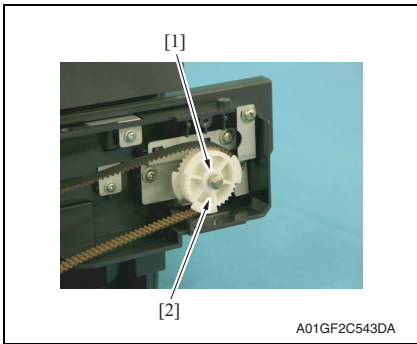

16. Remove the C-ring [1] and remove the gear (upper front) [2].

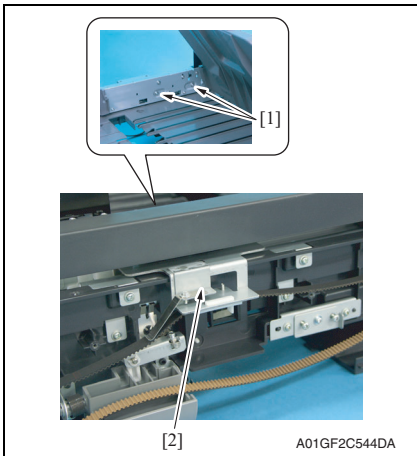

17. Remove two screws [1] and remove elevator mounting plate (front) [2].

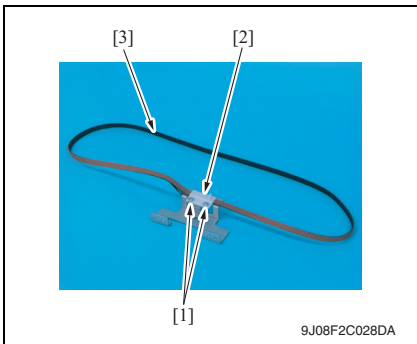

18. Remove two screws [1] and remove the belt holder [2].

19. Remove the timing belt (front) [3].

### B. Adjustment of lever installation position

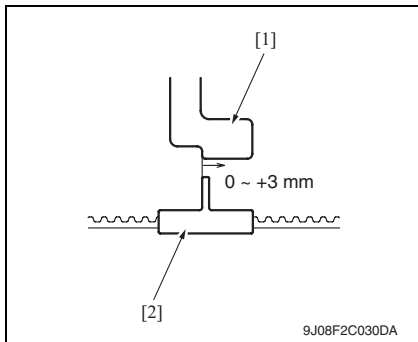
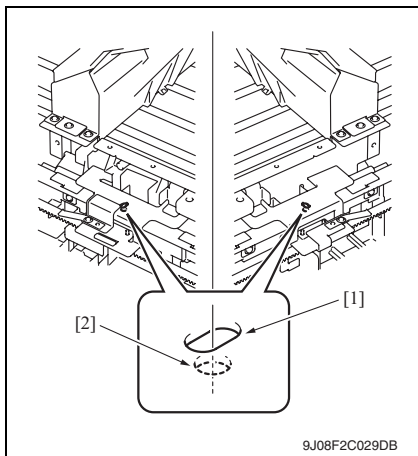

1. Install all components excepting for elevator motor assy.

#### NOTE

- Fit the hole of the elevator mounting plate (front/back) [1] and the hole of the elevator tray [2], and install them by fixing the front and back along.

2. Fit the blocked plate [1] as shown in the illustration, and install the lever [2].  
Specifications: 0 to +3 mm
3. Install the elevator motor assy.

### 3.4.21 Shutter drive gear

1. Remove the tray unit.  
See P.25
2. Remove the tray unit front cover.  
See P.23
3. Remove the tray unit rear cover.  
See P.23

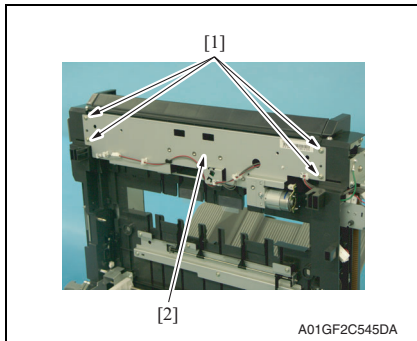

4. Remove four screws [1] and remove the shutter drive gear assy [2].

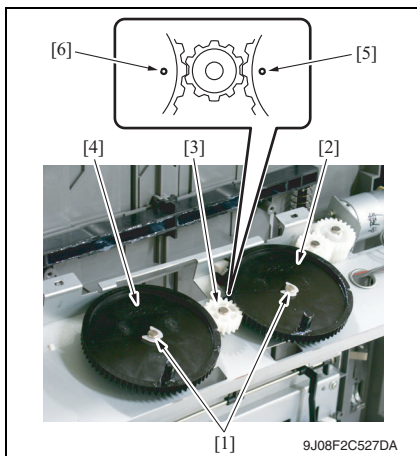

5. Remove two C-rings [1] and remove the gear 1 [2], gear 2 [3] and gear 3 [4].

#### NOTE

- When installing the shutter drive gear, fit the match marks [5] of gear 1 and [6] of gear 3 as shown in the left illustration.

### 3.4.22 Duplex guide solenoid

1. Remove the finisher unit.  
[See P.28](#)
2. Remove the finisher unit rear cover.  
[See P.20](#)
3. Remove the finisher unit upper cover.  
[See P.21](#)

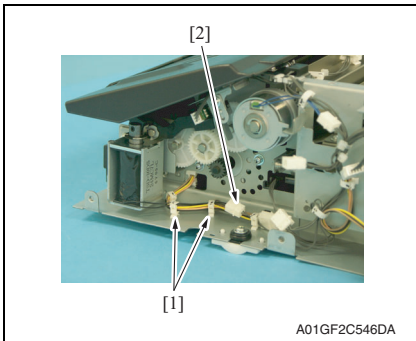

4. Remove two saddles [1] and disconnect the connector [2].

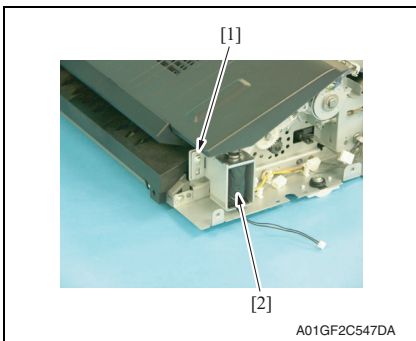

5. Remove the screw [1] and remove the duplex guide solenoid [2].

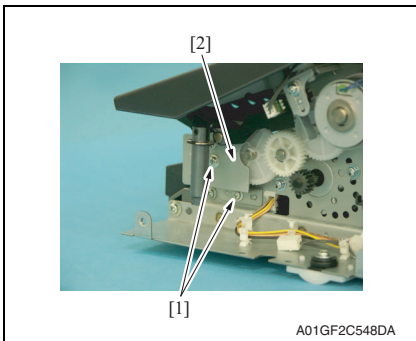

6. Remove two screws [1] and remove the duplex guide solenoid lever assy [2].

### A. Adjustment

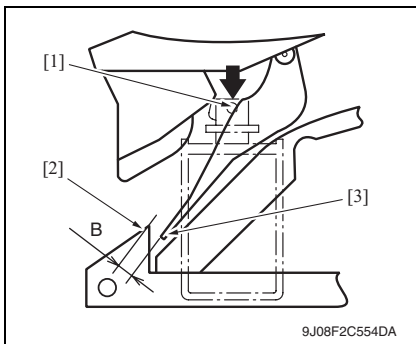
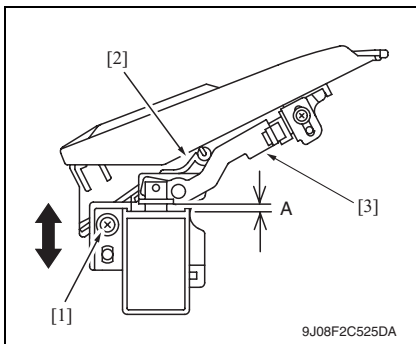

1. Loosen the screw [1].
2. Move the mounting plate up and down until the space A reaches specification, and tighten the screw [1].  
Specification: 3.5 mm (Tolerance: + 0.5 mm)

#### NOTE

- The switch tab [2] shall face down and touch to the lever [3].

3. Lift down the plunger [1], and make sure that the gap B between switch tab end [2] and the guide [3] is over 5 mm.

### 3.4.23 FS control board

1. Remove the tray unit.  
See P.25

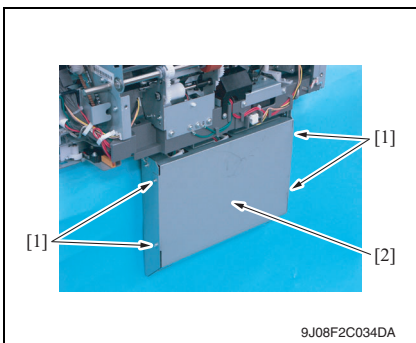

2. Remove four screws [1] and remove the cover [2].

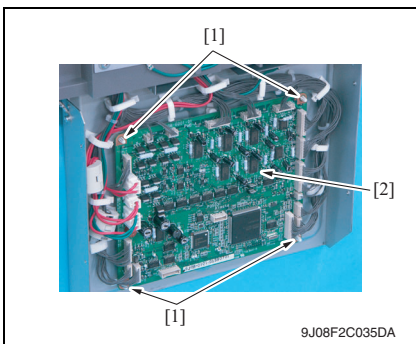

3. Disconnect all the connectors on the FS control board.
4. Remove four board supports [1], and remove the FS control board [2].

# Adjustment/Setting

## 4. How to use the adjustment section

- “Adjustment/Setting” contains detailed information on the adjustment items and procedures for this machine.
- Throughout this “Adjustment/Setting,” the default settings are indicated by “ ”.

### Advance checks

- Before attempting to solve the customer problem, the following advance checks must be made. Check to see if:
  - The power supply voltage meets the specifications.
  - The power supply is properly grounded.
  - The machine shares the power supply with any other machine that draws large current intermittently (e.g., elevator and air conditioner that generate electric noise).
  - The installation site is environmentally appropriate: high temperature, high humidity, direct sunlight, ventilation, etc.; levelness of the installation site.
  - The original has a problem that may cause a defective image.
  - The density is properly selected.
  - The original glass, slit glass, or related part is dirty.
  - Correct paper is being used for printing.
  - The units, parts, and supplies used for printing (developer, PC drum, etc.) are properly replenished and replaced when they reach the end of their useful service life.
  - Toner is not running out.

### CAUTION

- **To unplug the power cord of the machine before starting the service job procedures.**
- **If it is unavoidably necessary to service the machine with its power turned ON, use utmost care not to be caught in the scanner cables or gears of the exposure unit.**
- **Special care should be used when handling the fusing unit which can be extremely hot.**
- **The developing unit has a strong magnetic field. Keep watches and measuring instruments away from it.**
- **Take care not to damage the PC drum with a tool or similar device.**
- **Do not touch IC pins with bare hands.**



# 5. Sensor Check

## 5.1 Check procedure

### A. Procedure

1. Call the Service Mode to the screen.  
[See P.338 of the main body service manual.](#)
2. Touch [State Confirmation].
3. Touch [Sensor Check].
4. Touch two times [↕].

### 5.1.1 Sensor check screen

- This is only typical screen which may be different from what are shown on each individual main body.

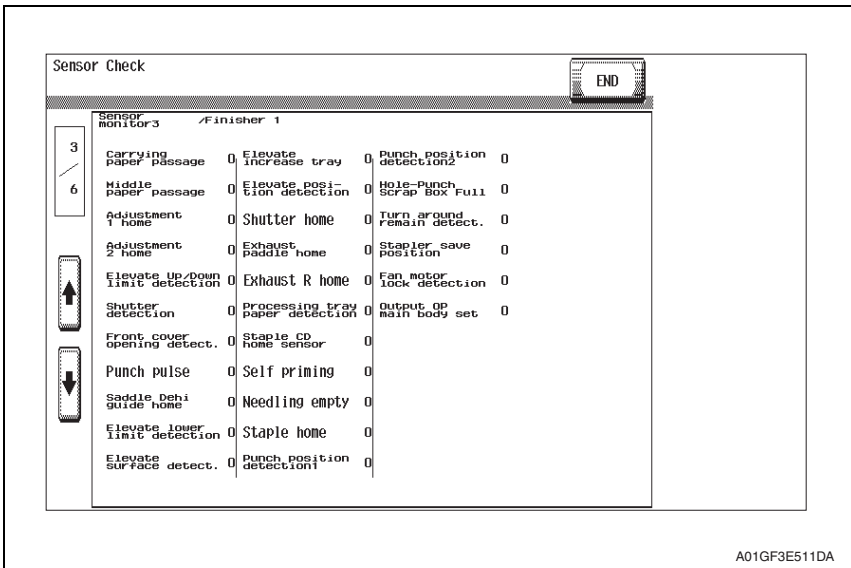

A01GF3E511DA

5.1.2 Sensor check list

Symbol	Panel display	Part/signal name	Operation characteristics/ panel display	
			1	0
PS1	Carrying Paper Passage	Entrance sensor	Paper present	Paper not present
PS2	Middle Paper Passage	Transport sensor	Paper present	Paper not present
PS7	Home1 (CD-Align)	Alignment home position sensor /1	At home	Not at home
PS8	Home2 (CD-Align)	Alignment home position sensor /2	At home	Not at home
SW3	Elevate Tray Raised/ Lowered	Elevator tray switch	ON	OFF
SW2	Shutter	Shutter detect switch	Closed	Open
SW1	Front Cover	Front door switch	Closed	Open
PS700	Punch Pulse	Punch motor pulse sensor	Blocked	Unblocked
PS23	Home (Saddle In and Out)	In & out guide home position sensor	Blocked	Unblocked
PS13	Elevate Tray Lowered	Elevator tray lower limit sensor	Blocked	Unblocked
PS12	Surface (Elev.)	Elevator top face detection sensor	Blocked	Unblocked
—	Elevate Tray Proliferation	Short connector	Set	Not set
PS11	Elevate Position	Elevator tray home position sensor	Blocked	Unblocked
PS14	Home (Shutter)	Shutter home position sensor	Blocked	Unblocked
PS6	Home (Exit Paddle)	Exit paddle home position sensor	Blocked	Unblocked
PS5	Home (Exit R)	Exit roller home position sensor	Blocked	Unblocked
PS3	Empty (Finisher)	Storage tray detect sensor	Blocked	Unblocked
PS9	Home (Staple CD)	Staple home position sensor	Blocked	Unblocked
—	Self Printing	Self-priming sensor	Blocked	Unblocked
—	Staple Empty	Staple empty detection sensor	Blocked	Unblocked
—	Home (Stapler)	Staple home position sensor	Blocked	Unblocked
PS500	Punch Position1	Punch cam sensor	Unblocked	Blocked
PS600	Punch Position2	Punch home position sensor	Unblocked	Blocked
PS30	Punch Dust Full	Punch Trash full sensor	Blocked	Unblocked
PS4	Remain in Reverse Section	Entrance switch back sensor	Unblocked	Blocked
PS10	Stapler Save Position	Stapler save position sensor	Blocked	Unblocked
FM9	Fan Motor Lock	Cooling fan motor	When turning	When stopped
SW4	Exit OP Machine Set	Slide switch	Set	Not set

Sensors monitor 3

FS-519/PK-515/OT-602

Adjustment / Setting

## 6. Finisher operations

### 6.1 CB-FN adjustment

#### 6.1.1 Finisher Check

##### A. Entering Finisher

1. Call the Service Mode to the screen.  
[See P.338 of the main body service manual.](#)
2. Touch [Finisher].
3. Touch [CB-FN adjustment].
4. Touch [Finisher Check].
5. Touch the item one wants.

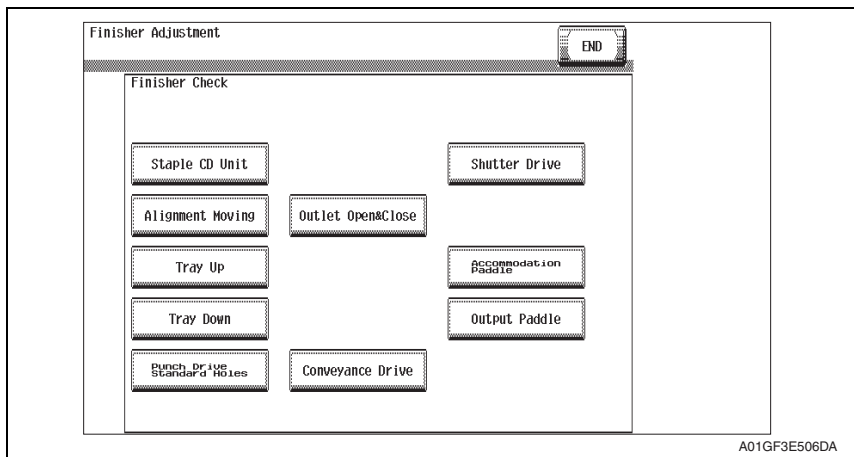

##### B. Finisher Check

###### (1) Staple CD Unit

- Returns the staple unit to the predetermined position after it moves to the 2-point stapling position for A4.
  - Moves from the predetermined position to the inner 2-point stapling position for A4.
  - Moves from the starting position and stops after the predetermined time.
  - Moves to the front of A4.
  - Moves from the starting position and stops after the predetermined time.
  - Moves to the predetermined position.
  - The operation is finished.

###### (2) Alignment Moving

- Aligning plates 1 and 2 return to the predetermined position after moving to the aligning position for A4S.
  - Moves from the predetermined position to the second predetermined position for A4S.
  - Stops after the predetermined time.
  - Moves to the aligning position for A4S.
  - Stops after the predetermined time.
  - Moves to the predetermined position.
  - The operation is finished.

**(3) Tray Up**

- The elevator tray is raised to bin 1. (Bin 1 → Additional bin → Bin 2)
  - The exit opens.
  - The shutter closes.
  - The paper output tray is raised to bin 1.
  - The shutter opens.
  - The exit closes.
  - The operation is finished.

**(4) Tray Down**

- The elevator tray is lowered from bin 1. (Bin 2 → Additional bin → Bin 1)
  - The exit opens.
  - The shutter closes.
  - The paper output tray is lowered from bin 1.
  - The shutter opens.
  - The exit closes.
  - The operation is finished.

**(5) Punch Drive Standard Holes (appears only when the punch kit PK-515 is installed)**

- The punch is driven once at a standard hole.
  - The operation is finished.

**(6) Punch Drive MC 2Holes (appears only when the punch kit PK-515 is installed)**

- The punch is driven once at a 2holes.
  - The operation is finished.

**(7) Outlet Open & Close**

- Opens and closes the exit.
  - The exit opens.
  - Stops after the predetermined time.
  - The exit closes.
  - The operation is finished.

**(8) Fold Drive (appears only when the saddle kit SD-505 is installed)**

[See P.29 of the SD-505 service manual.](#)

**(9) Saddle Outlet Open & Close (appears only when the saddle kit SD-505 is installed)**

[See P.29 of the SD-505 service manual.](#)

**(10) Conveyance Drive (appears only when the saddle kit SD-505 is installed)**

[See P.29 of the SD-505 service manual.](#)

**(11) Shutter Drive**

- Opens and closes the shutter.
  - The exit opens.
  - The shutter closes.
  - Stops after the predetermined time.
  - The shutter opens.
  - The exit closes.
  - The operation is finished.

**(12) Bin SL Drive (appears only when the mail bin kit MT-502 is installed)**

[See P.10 of the MT-502 service manual.](#)

**(13) Accommodation Paddle**

- Drive the storage paddle two turns  
→ The operation is finished,

**(14) Output Paddle**

- Drive the exit paddle one turn  
→ The operation is finished,

**6.1.2 Punch Register Loop Size**

**NOTE**

This adjustment must be made in any of the following cases:

- When a slant occurs in the punch hole position.
- When misfeed frequently occurs in punch hole mode.

1. Call the Service Mode to the screen.  
[See P.338 of the main body service manual.](#)
2. Touch [Finisher].
3. Touch [CB-FN adjustment].
4. Touch [Punch Register Loop Size].

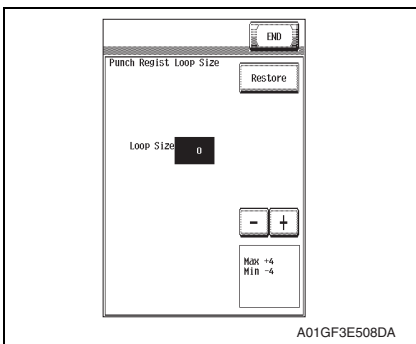

5. Set the correction value using the [-]/[+] keys.
  - Adjustment range: +4 max. and -4 min. (1 increment: 1 mm)
  - To make loop length larger, enter a positive value.
  - To make loop length smaller, enter a positive value.

6. Touch two times [END].
7. Touch [Exit] on the Service Mode screen.
8. Turn OFF the main power switch, wait for 10 sec., then turn the switch ON.
9. Make a copy again and check the deviance of punch hole position.

**6.1.3 Punch Horizontal Position**

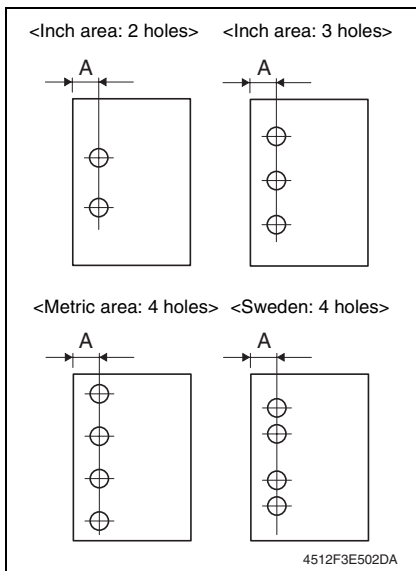

4. Call the Service Mode to the screen.
5. Touch [Finisher].
6. Touch [CB-FN adjustment].
7. Touch [Punch Horizontal Position].

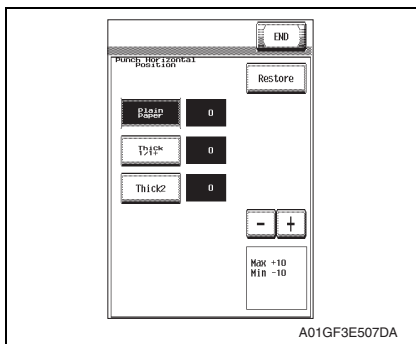

1. Set the copier into the hole punch mode and make a 1-sided copy from a 1-sided original.
  2. Measure width A on the copy and check to see if the measured dimension falls within the specified range.  
 <Inch area: 2 holes, 3 holes>  
 Specifications: 9.5 ± 1.0 mm  
 <Metric area: 4 holes>  
 Specifications: 11 ± 1.0 mm  
 <Sweden: 4 holes>  
 Specifications: 11.5 ± 1.0 mm
  3. If the measured width A outside the specified range, perform the following procedure to punch hole position adjustment.
8. Set the correction value using the [+]/[-] keys.
    - To make width A wider, enter a positive value.
    - To make width A narrower, enter a negative value.
    - Adjustment range: +10 max. and -10 min. (1 increment: 0.5 mm)
  9. Touch two times [END].
  10. Touch [Exit] on the Service Mode screen.
  11. Turn OFF the main power switch, wait for 10 sec., then turn the switch ON.
  12. Make a copy and check the punch hole positions again.

## ⚠ 6.2 Punch option setting

Functions	<ul style="list-style-type: none"> <li>To set installation and model of the punch kit.</li> <li>To set the number of holes to be made by the punch kit installed.</li> </ul>
Use	<ul style="list-style-type: none"> <li>Use when the punch kit is installed.</li> </ul>
Setting/ Procedure	<ul style="list-style-type: none"> <li>The default setting is Non-installat.</li> </ul> <ol style="list-style-type: none"> <li>1. Touch [PK-515].</li> <li>2. Select the number of punch holes to be made corresponding to the model and destination.</li> <li>3. Touch [decision].</li> <li>4. Turn off the main power switch and turn it on again more than 10 seconds after.</li> </ol>

## 7. Mechanical adjustment

### 7.1 Punch hole deviance adjustment (PK-515)

**NOTE**

Make this adjustment after any of the following procedures has been performed.

- When the punch kit has been replaced.
- When the punch kit has been removed.

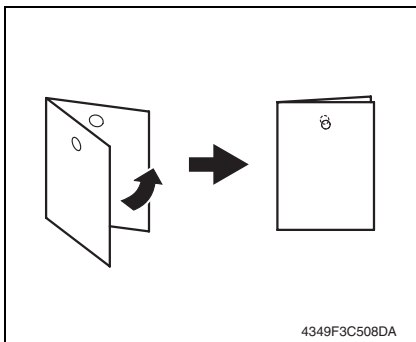

1. Set the copier into the hole punch mode and make a 1-sided copy from a 1-sided original.
2. Fold the output paper in half and check whether the punch hole positions are aligned.  
Specification:  $0 \pm 2$  mm
3. If the punch hole position is misaligned, adjust with the following procedure.

4. Remove the finisher unit right front cover.  
[See P.20](#)

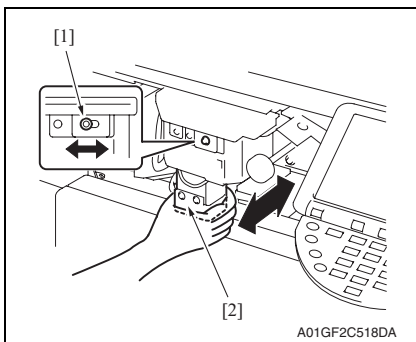

5. Loosen the adjustment screw [1], and move the punch unit [2] forward or backward to make the adjustment.
6. After the adjustment has been completed, tighten the adjusting screw.
7. Make a copy and check the punch hole positions again.



## 7.2 Staple position adjustment

### NOTE

Make this adjustment after any of the following procedures has been performed.

- When the stapler has been replaced.
- When staple position is misaligned.

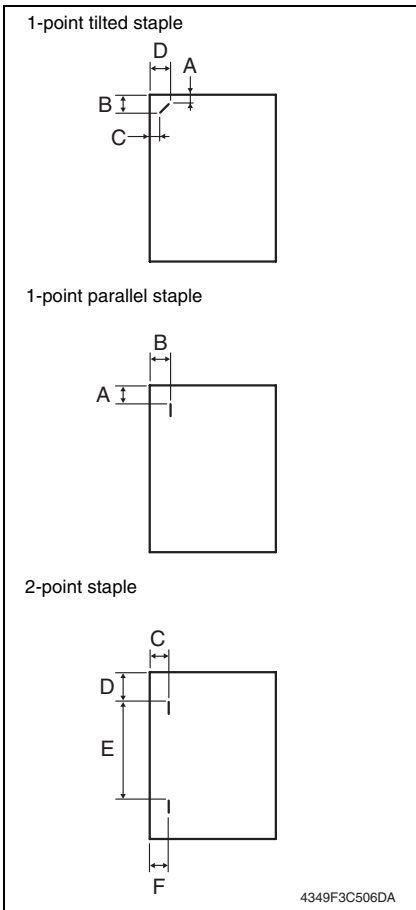

1. Set the staple mode and make a copy.
2. Check the staple position of the paper.
  - 1-point tilted staple  
(Paper width: 216 to 297 mm)  
279 to 297 mm: 45° tilt,  
B5, B4S: 30° tilt

Measurement position	Specification	Adjustment range
A	4.9 mm	-3 mm to +3 mm
B	10.1 mm	-4 mm to +4 mm
C	6.5 mm	-3 mm to +3 mm
D	16.2 mm	-4 mm to +4 mm

- 1-point parallel staple  
(Paper width: 182 to 216 mm)

Measurement position	Specification	Adjustment range
A	4.5 mm	-3 mm to +3 mm
B	6 mm	-4 mm to +4 mm

- 2-point staple

Measurement position	Specification	Adjustment range
C, F	6 mm	-4 mm to +4 mm
D	Y	-4 mm to +4 mm
E	X	-4 mm to +4 mm

$Y = (\text{paper width} - X - 11) / 2$

- X = A3, A4: 137  
 B4, B5: 114  
 A4S: 190  
 B5S: 162

Substitute above into the equation.

3. If the staple position is misaligned, adjust with the following procedure.

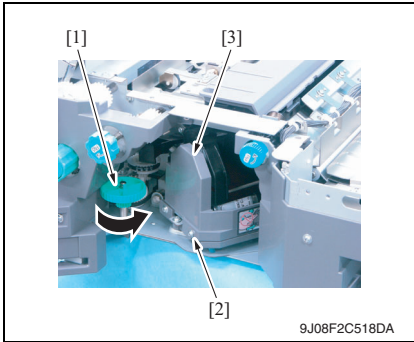

4. Open the front door.
5. Turn the dial [1], and move the stapler forward.
6. Loosen the screw [2], and remove the cover [3].

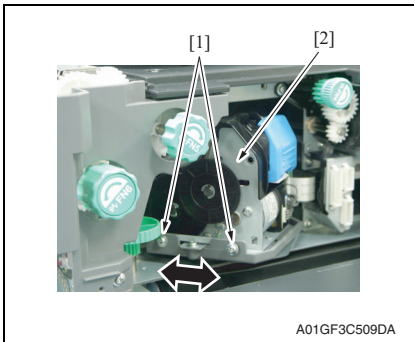

7. Loosen two adjustment screws [1] and move the stapler unit [2] in the direction of the arrow to make the adjustment.
8. Make another copy and check the staple position.

### 7.3 Staple home position sensor position adjustment

#### NOTE

Make this adjustment after any of the following procedures has been performed.

- When the stapler has been replaced.
- When staple position is misaligned.

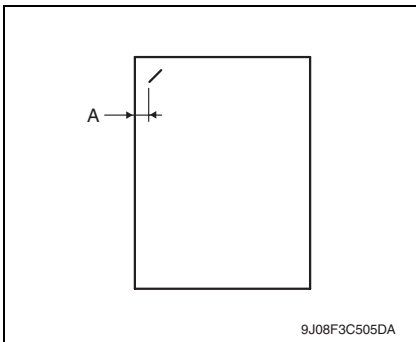

1. Set the staple mode and make a copy.
2. Check the staple position of the paper.
- 1-point tilted staple  
(Paper width: 216 to 297 mm)  
Specification A: 6.5 mm ± 1.5 mm
3. If the staple position does not fall within the specified range, make an adjustment as shown below.

4. Remove the tray unit.  
See P.25

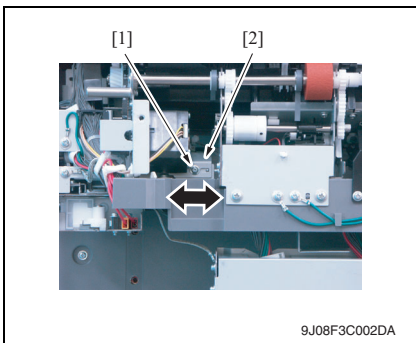

5. Loosen the screw [1] and make the adjustment by shifting stapler home sensor [2] in the direction of an arrow.

### 7.4 Adjustment of clearance between stapler and FD stopper

#### NOTE

Make this adjustment after any of the following procedures has been performed.

- When stapler fails to move appropriately.

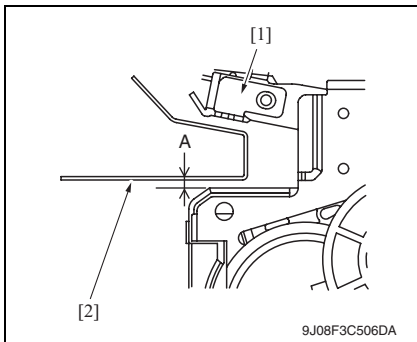

1. Check the clearance between the stapler unit [1] and the FD stopper [2] is within the specified range.  
Specification A: 2.0 mm ± 0.5 mm
2. If the value does not fall within the specified range, make the adjustment as shown below.

3. Remove the finisher unit.  
[See P.28](#)
4. Remove the finisher unit rear cover.  
[See P.20](#)

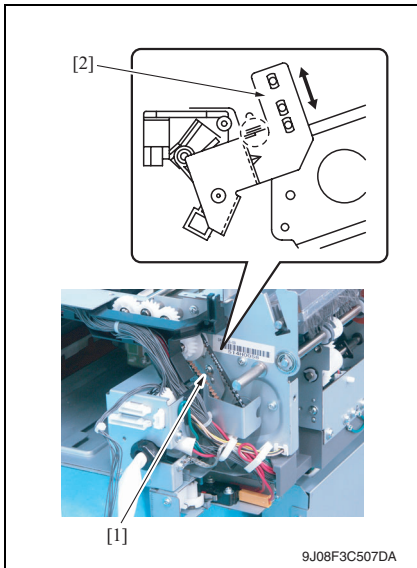

5. Loosen the screw [1] and move the mounting plate [2] to adjust.

Blank Page

# Troubleshooting

## 8. Jam display

### 8.1 Misfeed display

- When a paper misfeed occurs, the misfeed message, misfeed location, and paper location are displayed on the touch panel of the machine.

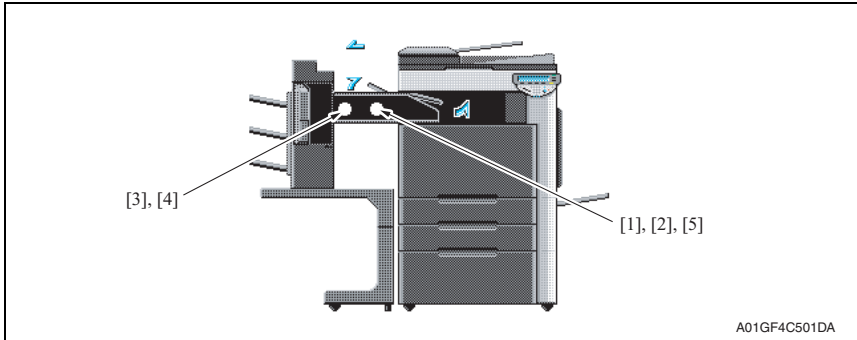

Display	Code	Misfeed location	Misfeed processing location	Action
[1]	7218	Finisher transport section misfeed	Front door	<a href="#">P.76</a>
[2]	7216	Finisher exit section misfeed	Front door	<a href="#">P.77</a>
[3]	7221	Finisher bundle exit misfeed	Front door	<a href="#">P.77</a>
[4]	7281	Finisher staple misfeed	Front door	<a href="#">P.78</a>
[5]	7243	Finisher punch misfeed	Front door	<a href="#">P.78</a>

#### 8.1.1 Misfeed display resetting procedure

- Open the corresponding door, clear the sheet of paper misfed, and close the door.

## 8.2 Sensor layout

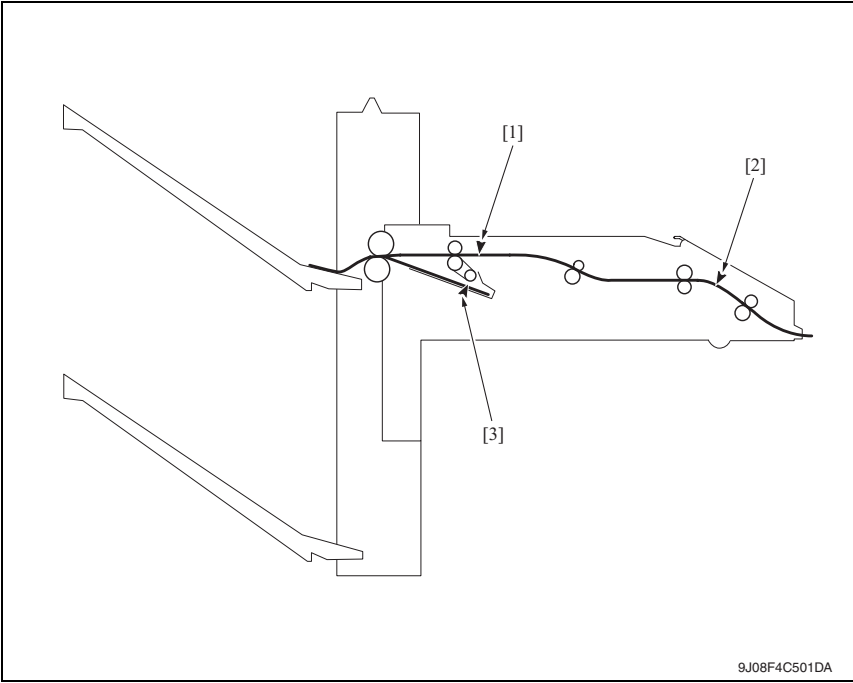

- |     |                            |     |
|-----|----------------------------|-----|
| [1] | Transport sensor           | PS2 |
| [2] | Entrance sensor            | PS1 |
| [3] | Storage tray detect sensor | PS3 |

### 8.3 Solution

#### 8.3.1 Initial check items

- When a paper misfeed occurs, first perform the following initial check items.

Check Item	Action
Does the paper meet product specifications?	Change the paper.
Is paper curled, wavy, or damp?	See "Solution when paper curl occurs" on P.75.
Is a foreign object present along the paper path, or is the paper path deformed or worn?	Clean or change the paper path.
Are the rolls/rollers dirty, deformed, or worn?	Clean or change the defective roll/roller.
Are the edge guide and trailing edge stop at the correct position to accommodate the paper?	Set as necessary.
Are the actuators found operational when checked for correct operation?	Correct or change the defective actuator.

#### 8.3.2 Solution when paper curl occurs

Step	Check items/actions	OK	—
1	Turn over the stacked paper in the paper tray.	OK	—
		NG	Go to step 2.
2	Does paper curl occur just after a warm-up has been completed or the sleep mode has been turned OFF?	YES	Go to step 3.
	Does paper curl occur under normal conditions (under conditions other than those mentioned above)?	YES	Go to step 5.
3	1. Call the Service Mode to the screen. 2. Select [System 1] → [Change Warm Up Time]. 3. Change the setting to [Mode3]. See P.393 of the main body service manual.	OK	—
		NG	Go to step 4.
4	1. Call the Service Mode to the screen. 2. Select [System 1] → [Change Warm Up Time]. 3. Change the setting to [Mode4]. See P.393 of the main body service manual.	—	—
5	1. Call the Service Mode to the screen. 2. Select [Machine] → [Fusing Temperature]. 3. Select a paper type. 4. Change the temperature of Heater Roller to [-10 °C]. See P.345 of the main body service manual.	OK	—
		NG	Go to step 6
6	1. Call the Service Mode to the screen. 2. Select [Machine] → [Fusing Temperature]. 3. Select a paper type. 4. Change the temperature of Heater Roller to [-20 °C]. See P.345 of the main body service manual.	—	—



**8.3.3 Transport section misfeed**

**A. Detection timing**

Type	Description
Finisher transport section misfeed detection	The entrance sensor (PS1) is not turned ON even after the set period of time has elapsed after the copier's paper exit sensor (PS25) is turned ON by the paper.
	The entrance sensor (PS1) is not turned OFF even after the set period of time has elapsed after the copier's paper exit sensor (PS25) is turned OFF by the paper.
Finisher transport section misfeed detection	The entrance sensor (PS1) is turned ON when the power switch is set to ON, a door or cover is opened and closed, or a misfeed or malfunction is reset.
	The transport sensor (PS2) is turned ON when the power switch is set to ON, a door or cover is opened and closed, or a misfeed or malfunction is reset.

**B. Action**

Relevant electrical parts	
Paper exit sensor (PS25) Entrance sensor (PS1) Transport sensor (PS2)	FS control board (FSCB) MFP board (MFPB)



Step	Action	WIRING DIAGRAM	
		Control signal	Location (Electrical component)
1	Initial check items	—	—
2	PS25 I/O check, sensor check	—	—
3	PS1 I/O check, sensor check	FSCB PJ19-11 (ON)	FS-519 C-7
4	PS2 I/O check, sensor check	FSCB PJ19-14 (ON)	FS-519 C-7
5	Change FSCB	—	—
6	Change MFPB	—	—

**8.3.4 Exit section misfeed**

**A. Detection timing**

Type	Description
Finisher exit section misfeed detection	The transport sensor (PS2) is not turned ON even after the set period of time has elapsed after the entrance sensor (PS1) is turned ON by the paper.
	The transport sensor (PS2) is not turned OFF even after the set period of time has elapsed after the entrance sensor (PS1) is turned OFF by the paper.

**B. Action**

Relevant electrical parts	
Entrance sensor (PS1) Transport sensor (PS2)	FS control board (FSCB) MFP board (MFPB)



Step	Action	WIRING DIAGRAM	
		Control signal	Location (Electrical component)
1	Initial check items	—	—
2	PS1 I/O check, sensor check	FSCB PJ19-11 (ON)	FS-519 C-7
3	PS2 I/O check, sensor check	FSCB PJ19-14 (ON)	FS-519 C-7
4	Change FSCB	—	—
5	Change MFPB	—	—

**8.3.5 Finisher bundle exit misfeed**

**A. Detection timing**

Type	Description
Finisher bundle exit misfeed detection	The storage tray detect sensor (PS3) is not turned OFF even after the set period of time has elapsed after the exit motor (M4) is energized.

**B. Action**

Relevant electrical parts	
Storage tray detect sensor (PS3) Exit motor (M4)	FS control board (FSCB)



Step	Action	WIRING DIAGRAM	
		Control signal	Location (Electrical component)
1	Initial check items	—	—
2	PS3 I/O check, sensor check	FSCB PJ14-8 (ON)	FS-519 C-12
3	M4 operation check	FSCB PJ10-5 to 8	FS-519 C-3
4	Change FSCB	—	—



**8.3.6 Finisher staple misfeed**

**A. Detection timing**

Type	Description
Finisher staple misfeed detection	The staple home position sensor in the staple unit is not turned ON even after the set period of time has elapsed after the staple motor rotates forward, and then the staple motor rotates backward, and the staple home position sensor in the staple unit is turned ON within the set period of time.

**B. Action**

Relevant electrical parts	
Staple unit	FS control board (FSCB)

Step	Action	WIRING DIAGRAM	
		Control signal	Location (Electrical component)
1	Initial check items	—	—
2	Drive coupling section check	—	—
3	Sensor check	—	—
4	Change staple unit	—	—
5	Change FSCB	—	—

**8.3.7 Finisher punch misfeed (PK-515)**

**A. Detection timing**

Type	Description
Finisher punch misfeed detection	Punch positioning sensors 1 and 2 are not turned ON even after the set period of time has elapsed after the punch motor is energized.

**B. Action**

Relevant electrical parts	
Punch unit	FS control board (FSCB)

Step	Action	WIRING DIAGRAM	
		Control signal	Location (Electrical component)
1	Initial check items	—	—
2	Drive coupling section check	—	—
3	Sensor check	—	—
4	Change punch unit	—	—
5	Change FSCB	—	—

## 9. Malfunction code

### 9.1 Trouble code

- The machine's CPU performs a self-diagnostics function that, on detecting a malfunction, gives the corresponding malfunction code and maintenance call mark on the touch panel.

Code	Description	Detection timing
C1004	FNS communication error	<ul style="list-style-type: none"> <li>When the FS control board (FSCB) is receiving data, a communication error is detected.</li> </ul>
C1183	Elevator motor ascent/descent drive failure	<ul style="list-style-type: none"> <li>The elevator tray lower limit sensor (PS13) is not turned ON even after the set period of time has elapsed after the main power switch is set to ON.</li> <li>The elevator tray home position sensor (PS11) and elevator top face detection sensor (PS12) are not turned ON even after the set period of time has elapsed after the elevator motor (M11) is energized.</li> <li>The elevator tray does not stop at the position for the specified tray after the elevator motor (M11) is energized (beginning of descent operation) and the elevator tray lower limit sensor (PS13) is turned ON.</li> <li>The elevator top face detection sensor (PS12) is not turned ON even after the set period of time has elapsed after the elevator motor (M11) is energized (beginning of ascent operation) when paper is being fed out.</li> </ul>
C1190	Aligning plate 1 drive failure	<ul style="list-style-type: none"> <li>The alignment home position sensor/1 (PS7) is not turned ON even after the set period of time has elapsed after the main power switch is set to ON.</li> <li>The alignment home position sensor/1 (PS7) is not turned OFF even after the set period of time has elapsed after the align motor/1 (M5) is energized.</li> </ul>
C1191	Aligning plate 2 drive failure	<ul style="list-style-type: none"> <li>The alignment home position sensor/2 (PS8) is not turned ON even after the set period of time has elapsed after the main power switch is set to ON.</li> <li>The alignment home position sensor/2 (PS8) is not turned OFF even after the set period of time has elapsed after the align motor/2 (M6) is energized.</li> </ul>
C11A0	Paper holding drive failure	<ul style="list-style-type: none"> <li>The exit paddle home position sensor (PS6) is not turned ON even after the set period of time has elapsed after the exit paddle solenoid (SD2) is activated (beginning of paddle retraction operation).</li> <li>The exit paddle home position sensor (PS6) is not turned OFF even after the set period of time has elapsed after the exit paddle solenoid (SD2) is activated (beginning of paddle paper-holding operation).</li> </ul>
C11A1	Exit roller pressure/retraction failure	<ul style="list-style-type: none"> <li>The exit roller home position sensor (PS5) is not turned ON even after the set period of time has elapsed after the exit roller motor (M10) is energized (beginning of pressure operation).</li> <li>The exit roller home position sensor (PS5) is not turned OFF even after the set period of time has elapsed after the exit roller motor (M10) is energized (beginning of retraction operation).</li> </ul>

Code	Description	Detection timing
C11A3	Shutter drive failure	<ul style="list-style-type: none"> <li>The shutter home position sensor (PS14) is not turned OFF even after the set period of time has elapsed after the shutter motor (M8) is energized (beginning of shutter-opening operation).</li> <li>The shutter home position sensor (PS14) is not turned ON even after the set period of time has elapsed after the shutter motor (M8) is energized (beginning of shutter-closing operation).</li> </ul>
C11B0	Staple unit CD drive failure	<ul style="list-style-type: none"> <li>The staple home position sensor (PS9) is not turned ON even after the set period of time has elapsed after the stapling unit moving motor (M7) is energized (beginning of return operation to predetermined position).</li> </ul>
C11B2	Staple drive failure	<ul style="list-style-type: none"> <li>The home position sensor is not turned ON even after the set period of time has elapsed after the staple motor is energized (beginning of staple operation).</li> </ul>
C11C0	Punch cam motor unit failure	<ul style="list-style-type: none"> <li>The punch home position sensor (PS600) is not turned ON even after the set period of time has elapsed while the punch motor (M99) is energized.</li> </ul>
C1301	Finishing option cooling fan motor failure	<ul style="list-style-type: none"> <li>The cooling fan motor (FM9) lock signal remains set to H for a set period of time while the cooling fan motor (FM9) is turning.</li> <li>The cooling fan motor (FM9) lock signal remains set to L for a set period of time while the cooling fan motor (FM9) remains stopped.</li> </ul>
C1402	FNS nonvolatile memory failure	<ul style="list-style-type: none"> <li>When the main power switch is turned ON, the FS board nonvolatile memory failure is detected.</li> </ul>
CC155	Finisher ROM failure	<ul style="list-style-type: none"> <li>Data of flash ROM of the finishing options is determined to be faulty when the power is turned ON.</li> </ul>

## 9.2 Solution

### 9.2.1 C1004: FNS communication error

Relevant electrical parts			
FS control board (FSCB)			
Step	Action	WIRING DIAGRAM	
		Control signal	Location (Electrical component)
1	Disconnect and then connect the power cord. Turn OFF the main power switch, wait for 10 sec. or more, and turn ON the main power switch.	—	—
2	Rewrite firmware using the compact flash card.	—	—
3	Change FSCB	—	—

### 9.2.2 C1183: Elevator motor ascent/descent drive failure

Relevant electrical parts	
Elevator motor (M11) Elevator tray home position sensor (PS11) Elevator tray lower limit sensor (PS13)	Elevator top face detection sensor (PS12) Relay board/1 (REYB/1) FS control board (FSCB)



Step	Action	WIRING DIAGRAM	
		Control signal	Location (Electrical component)
1	Check the M11 connector for proper connection and correct as necessary.	—	—
2	Check M11 for proper drive coupling and correct as necessary.	—	—
3	If OT-602 is connected, check the connector for proper connection, and correct as necessary.	—	—
4	Check the installation position of the OT-602 tray, and correct as necessary.	—	—
5	M11 operation check	FSCB PJ6-5 to 6	FS-519 J-4
6	PS11 I/O check, sensor check	FSCB PJ18-6 (ON)	FS-519 L-3
7	PS13 I/O check, sensor check	FSCB PJ18-3 (ON)	FS-519 L-4
8	PS12 I/O check, sensor check	FSCB PJ18-4 (ON)	FS-519 L-3
9	Change REYB/1	—	—
10	Change FSCB	—	—

**9.2.3 C1190: Aligning plate 1 drive failure**

**9.2.4 C1191: Aligning plate 2 drive failure**

Relevant electrical parts	
Align motor/1 (M5) Align motor/2 (M6) Alignment home position sensor/1 (PS7) Alignment home position sensor/2 (PS8)	FS control board (FSCB)

• C1190

Step	Action	WIRING DIAGRAM	
		Control signal	Location (Electrical component)
1	Check the M5 connector for proper connection and correct as necessary.	—	—
2	Check M5 for proper drive coupling and correct as necessary.	—	—
3	M5 operation check	FSCB PJ11-1 to 4	FS-519 C-10
4	PS7 I/O check, sensor check	FSCB PJ14-3 (ON)	FS-519 C-11
5	Change FSCB	—	—

• C1191

Step	Action	WIRING DIAGRAM	
		Control signal	Location (Electrical component)
1	Check the M6 connector for proper connection and correct as necessary.	—	—
2	Check M6 for proper drive coupling and correct as necessary.	—	—
3	M6 operation check	FSCB PJ11-5 to 8	FS-519 C-11
4	PS8 I/O check, sensor check	FSCB PJ14-6 (ON)	FS-519 C-11
5	Change FSCB	—	—

**9.2.5 C11A0: Paper holding drive failure**

Relevant electrical parts	
Exit paddle solenoid (SD2) Exit paddle home position sensor (PS6)	FS control board (FSCB)



Step	Action	WIRING DIAGRAM	
		Control signal	Location (Electrical component)
1	Check the SD2 connector for proper connection and correct as necessary.	—	—
2	PS6 I/O check, sensor check	FSCB PJ13-11 (ON)	FS-519 C-4
3	SD2 operation check	FSCB PJ13-2 (REM)	FS-519 C-5
4	Change FSCB	—	—

**9.2.6 C11A1: Exit roller pressure/retraction failure**

Relevant electrical parts	
Exit roller motor (M10) Exit roller home position sensor (PS5)	FS control board (FSCB)



Step	Action	WIRING DIAGRAM	
		Control signal	Location (Electrical component)
1	Check the M10 connector for proper connection and correct as necessary.	—	—
2	Check M10 for proper drive coupling and correct as necessary.	—	—
3	M10 operation check	FSCB PJ12-8 to 9	FS-519 C-9
4	PS5 I/O check, sensor check	FSCB PJ19-3 (ON)	FS-519 C-8
5	Change FSCB	—	—



**9.2.7 C11A3: Shutter drive failure**

Relevant electrical parts	
Shutter motor (M8)	Relay board/1 (REYB/1)
Shutter home position sensor (PS14)	FS control board (FSCB)



Step	Action	WIRING DIAGRAM	
		Control signal	Location (Electrical component)
1	Check the M8 connector for proper connection and correct as necessary.	—	—
2	Check M8 for proper drive coupling and correct as necessary.	—	—
3	M8 operation check	FSCB PJ6-7 to 8	FS-519 J-5
4	PS14 I/O check, sensor check	FSCB PJ18-5 (ON)	FS-519 J-5
5	Change REYB/1	—	—
6	Change FSCB	—	—

**9.2.8 C11B0: Staple unit CD drive failure**

Relevant electrical parts	
Stapling unit moving motor (M7)	FS control board (FSCB)
Staple home position sensor (PS9)	



Step	Action	WIRING DIAGRAM	
		Control signal	Location (Electrical component)
1	Check for interference with the shutter and exit roller, and correct as necessary.	—	—
2	Check the M7 connector for proper connection and correct as necessary.	—	—
3	Check M7 for proper drive coupling and correct as necessary.	—	—
4	M7 operation check	FSCB PJ10-1 to 4	FS-519 C-3 to 4
5	PS9 I/O check, sensor check	FSCB PJ13-5 (ON)	FS-519 C-4 to 5
6	Change FSCB	—	—

**9.2.9 C11B2: Staple drive failure**

Relevant electrical parts	
Staple unit	FS control board (FSCB)

Step	Action	WIRING DIAGRAM	
		Control signal	Location (Electrical component)
1	Check the staple unit connector for proper connection and correct as necessary.	—	—
2	Check the staple unit for proper drive coupling, and correct as necessary.	—	—
3	Staple unit operation check	—	—
4	Change staple unit	—	—
5	Change FSCB	—	—

**9.2.10 C11C0: Punch cam motor unit failure**

Relevant electrical parts	
Punch unit	FS control board (FSCB)

Step	Action	WIRING DIAGRAM	
		Control signal	Location (Electrical component)
1	Check the punch unit connectors for proper connection, and correct as necessary.	—	—
2	Check the punch unit for proper drive coupling, and correct as necessary.	—	—
3	Punch unit sensor check	—	—
4	Change punch unit	—	—
5	Change FSCB	—	—

FS-519/PK-515/OT-602

Troubleshooting

**9.2.11 C1301: Finishing option cooling fan motor failure**

Relevant electrical parts	
Cooling fan motor (FM9)	FS control board (FSCB)



Step	Action	WIRING DIAGRAM	
		Control signal	Location (Electrical component)
1	Check the FM9 connector for proper connection and correct as necessary.	—	—
2	Check FM9 for proper drive coupling and correct as necessary.	—	—
3	Check the FSCB connectors for proper connection, and correct as necessary.	—	—
4	FM9 operation check	FSCB PJ12-3	FS-519 C-10
5	Change FSCB	—	—

**9.2.12 C1402: FNS nonvolatile memory failure**

Relevant electrical parts	
FS control board (FSCB)	

Step	Action	WIRING DIAGRAM	
		Control signal	Location (Electrical component)
1	Disconnect and then connect the power cord. Turn OFF the main power switch, wait for 10 sec. or more, and turn ON the main power switch.	—	—
2	Rewrite firmware using the compact flash card.	—	—
3	Change FSCB	—	—

**9.2.13 CC155: Finisher ROM failure**

Relevant electrical parts	
FS control board (FSCB)	

Step	Action	WIRING DIAGRAM	
		Control signal	Location (Electrical component)
1	Disconnect and then connect the power cord. Turn OFF the main power switch, wait for 10 sec. or more, and turn ON the main power switch.	—	—
2	Rewrite firmware using the compact flash card.	—	—
3	Change FSCB	—	—

FS-519/PK-515/OT-602

Troubleshooting

Blank Page



KONICA MINOLTA

**SERVICE MANUAL**

FIELD SERVICE

---

# MT-502





# Revision history

After publication of this service manual, the parts and mechanism may be subject to change for improvement of their performance.

Therefore, the descriptions given in this service manual may not coincide with the actual machine.

When any change has been made to the descriptions in the service manual, a revised version will be issued with a revision mark added as required.

Revision mark:

- To indicate clearly a specific section revised within text,  is shown at the left margin of the corresponding revised section.  
The number inside  represents the number of times the revision has been made.
- To indicate clearly a specific page that contains a revision or revisions, the page number appearing at the left or right bottom of the specific page is marked with .  
The number inside  represents the number of times the revision has been made.

## NOTE

Revision marks shown in a page are restricted only to the latest ones with the old ones deleted.

- When a page revised in Ver. 2.0 has been changed in Ver. 3.0:  
The revision marks for Ver. 3.0 only are shown with those for Ver. 2.0 deleted.
- When a page revised in Ver. 2.0 has not been changed in Ver. 3.0:  
The revision marks for Ver. 2.0 are left as they are.

2008/01	2.0		Error correction
2007/07	1.0	—	Issue of the first edition
Date	Service manual Ver.	Revision mark	Descriptions of revision

# CONTENTS

## MT-502

### General

1. Product specification ..... 1

### Maintenance

2. Other ..... 3

2.1 Disassembly/adjustment prohibited items ..... 3

2.2 Disassembly/Assembly/Cleaning list (Other parts) ..... 4

    2.2.1 Disassembly/Assembly parts list ..... 4

    2.2.2 Cleaning parts list ..... 4

2.3 Disassembly/Assembly procedure ..... 4

    2.3.1 Rear cover/Right door ..... 4

    2.3.2 Front cover/Upper cover/Paper output tray ..... 5

2.4 Cleaning procedure ..... 5

    2.4.1 Cleaning of the roller and roll ..... 5

### Adjustment/Setting

3. How to use the adjustment section ..... 7

4. Sensor check ..... 8

    4.1 Check procedure ..... 8

        4.1.1 Sensor check screen ..... 8

        4.1.2 Sensor check list ..... 9

5. Finisher operations ..... 10

    5.1 Entering Finisher Check ..... 10

    5.2 Finisher Check modes ..... 10

### Troubleshooting

6. Jam display ..... 11

    6.1 Misfeed display ..... 11

        6.1.1 Misfeed display resetting procedure ..... 11

    6.2 Sensor layout ..... 12

    6.3 Solution ..... 13

        6.3.1 Initial check items ..... 13

        6.3.2 Solution when paper curl occurs ..... 13

        6.3.3 Transport section misfeed ..... 14



MT-502

General

Maintenance

Adjustment / Setting

Troubleshooting

Blank Page

# General

## 1. Product specification

### A. Type

Name	Mailbin kit	
Installation	Install at the top section of the finisher elevator tray.	
Number of bins	4 bins	
Number of sheets stored per bin	125 sheets (Total 500 sheets) (90 g/m <sup>2</sup> , 24 lb)	
Storable paper	Plain paper	60 to 90 g/m <sup>2</sup> (16 to 24 lb)
	Recycled paper	
Storable paper size	Metric area	A5S, B5, A4
	Inch area	5 <sup>-1/2</sup> x 8 <sup>-1/2</sup> S, 8 <sup>-1/2</sup> x 11

### B. Machine specifications

Power requirements	DC 24 V (Supplied from the finisher) DC 5 V (Generated inside the mail bin)
Dimensions	340 mm (W) x 509 mm (D) x 387 mm (H) 13.5 inch (W) x 20 inch (D) x 15.25 inch (H)
Weight	8.0 kg (17.75 lb)

### C. Operating environment

- Conforms to the operating environment of the main body.

#### NOTE

- These specifications are subject to change without notice.

Blank Page

# Maintenance

## 2. Other

### 2.1 Disassembly/adjustment prohibited items

#### A. Paint-locked screws

##### NOTE

- To prevent loose screws, a screw lock in blue or green series color is applied to the screws.
- The screw lock is applied to the screws that may get loose due to the vibrations and loads created by the use of machine or due to the vibrations created during transportation.
- If the screw lock coated screws are loosened or removed, be sure to apply a screw lock after the screws are tightened.

#### B. Red-painted screws

##### NOTE

- The screws which are difficult to be adjusted in the field are painted in red in order to prevent them from being removed by mistake.
- Do not remove or loosen any of the red-painted screws in the field. It should also be noted that, when two or more screws are used for a single part, only one representative screw may be marked with the red paint.

#### C. Variable resistors on board

##### NOTE

- Do not turn the variable resistors on boards for which no adjusting instructions are given in Adjustment/Setting.

#### D. Removal of PWBs

##### CAUTION

- When removing a circuit board or other electrical component, refer to “Handling of PWBs” and follow the corresponding removal procedures.
- The removal procedures given in the following omit the removal of connectors and screws securing the circuit board support or circuit board.
- Where it is absolutely necessary to touch the ICs and other electrical components on the board, be sure to ground your body.

## 2.2 Disassembly/Assembly/Cleaning list (Other parts)

### 2.2.1 Disassembly/Assembly parts list

No.	Section	Part name	Ref. page
1	Exterior parts	Rear cover	P.4
2		Front cover	P.5
3		Upper cover	P.5
4		Right door	P.4
5		Paper output tray	P.5

### 2.2.2 Cleaning parts list

No.	Section	Part name	Ref. page
1	Exit section	Roller and roll	P.5

## 2.3 Disassembly/Assembly procedure

### 2.3.1 Rear cover/Right door

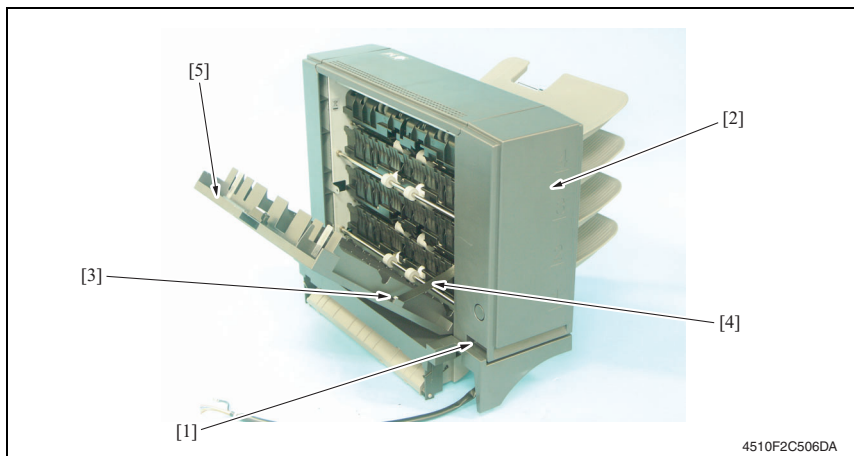

4510F2C506DA

1. Remove the screw [1] and remove the rear cover [2].
2. Remove the screw [3], the stopper [4], and remove the right door [5].

### 2.3.2 Front cover/Upper cover/Paper output tray

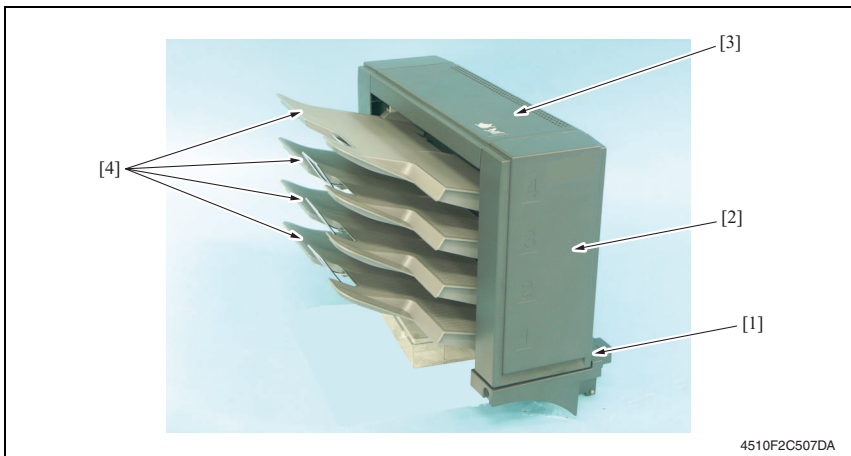

1. Remove the screw [1] and remove the front cover [2].
2. Remove the rear cover.  
[See P.4](#)
3. Remove the upper cover [3].
4. Remove the paper output trays [4].

## 2.4 Cleaning procedure

### NOTE

- The alcohol described in the cleaning procedure of maintenance represents the isopropyl alcohol.

### 2.4.1 Cleaning of the roller and roll

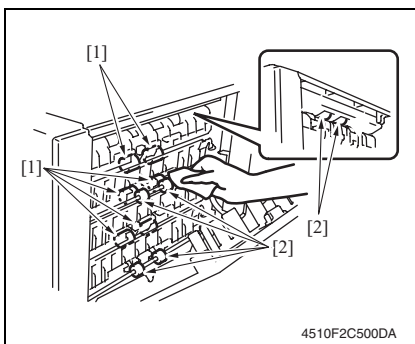

1. Open the right door.
2. Using a cleaning pad dampened with alcohol, wipe the roller [1] and roll [2].

MT-502

Maintenance

Blank Page

# Adjustment/Setting

## 3. How to use the adjustment section

- “Adjustment/Setting” contains detailed information on the adjustment items and procedures for this machine.
- Throughout this “Adjustment/Setting,” the default settings are indicated by “ ”.

### Advance checks

Before attempting to solve the customer problem, the following advance checks must be made. Check to see if:

- The power supply voltage meets the specifications.
- The power supply is properly grounded.
- The machine shares the power supply with any other machine that draws large current intermittently (e.g., elevator and air conditioner that generate electric noise).
- The installation site is environmentally appropriate: high temperature, high humidity, direct sunlight, ventilation, etc.; levelness of the installation site.
- The original has a problem that may cause a defective image.
- The density is properly selected.
- The original glass, slit glass, or related part is dirty.
- Correct paper is being used for printing.
- The units, parts, and supplies used for printing (developer, PC drum, etc.) are properly replenished and replaced when they reach the end of their useful service life.
- Toner is not running out.

### CAUTION

- **To unplug the power cord of the machine before starting the service job procedures.**
- **If it is unavoidably necessary to service the machine with its power turned ON, use utmost care not to be caught in the scanner cables or gears of the exposure unit.**
- **Special care should be used when handling the fusing unit which can be extremely hot.**
- **The developing unit has a strong magnetic field. Keep watches and measuring instruments away from it.**
- **Take care not to damage the PC drum with a tool or similar device.**
- **Do not touch IC pins with bare hands.**



# 4. Sensor check

## 4.1 Check procedure

### A. Procedure

1. Call the Service Mode to the screen.  
[See P.338 of the main body service manual.](#)
2. Touch [State Confirmation].
3. Touch [Sensor Check].
4. Touch three times [↕].

#### 4.1.1 Sensor check screen

- This is only typical screen which may be different from what are shown on each individual main body.

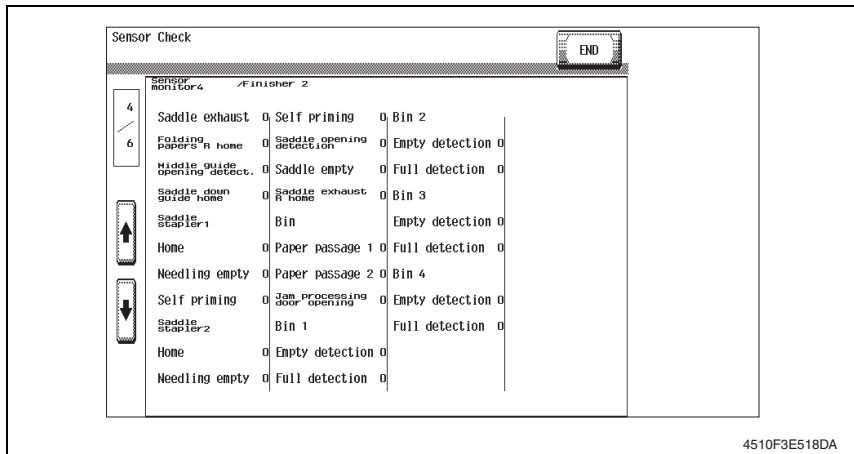

4510F3E518DA

**4.1.2 Sensor check list**

Symbol	Panel display		Part/signal name	Operation characteristics/ panel display	
				1	0
PS10	Bin	Paper Passage 1	Lower transport sensor	Paper present	Paper not present
PS9		Paper Passage 2	Upper transport sensor	Paper present	Paper not present
PS11		Door (Jam)	Cover open/close sensor	Open	Close
PS1	Bin1	Empty	Paper detection sensor 1	Paper not present	Paper present
PS5		Full	Paper full detection sensor 1	Blocked	Unblocked
PS2	Bin2	Empty	Paper detection sensor 2	Paper not present	Paper present
PS6		Full	Paper full detection sensor 2	Blocked	Unblocked
PS3	Bin3	Empty	Paper detection sensor 3	Paper not present	Paper present
PS7		Full	Paper full detection sensor 3	Blocked	Unblocked
PS4	Bin4	Empty	Paper detection sensor 4	Paper not present	Paper present
PS8		Full	Paper full detection sensor 4	Blocked	Unblocked

MT-502

Adjustment / Setting

# 5. Finisher operations

## 5.1 Entering Finisher Check

1. Call the Service Mode to the screen.  
[See P.338 of the main body service manual.](#)
2. Touch [Finisher].
3. Touch [CB-FN adjustment].
4. Touch [Finisher Check].
5. Touch [Bin SL Drive].

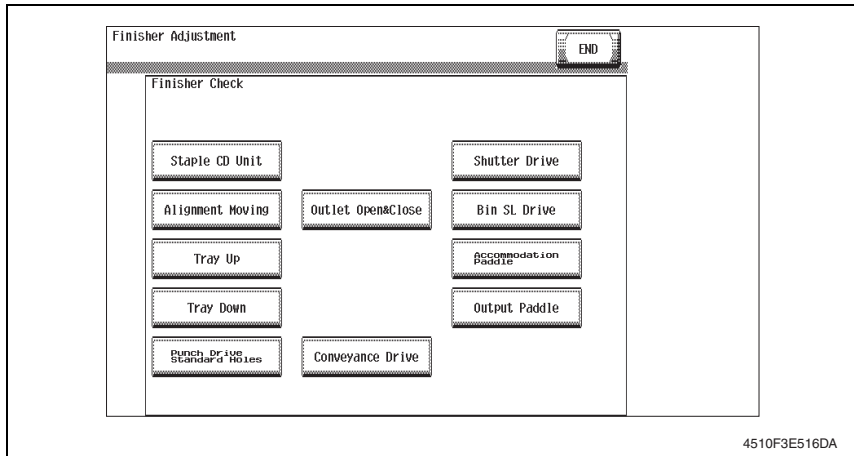

## 5.2 Finisher Check modes

### A. Bin SL Drive

- Bin entrance switching solenoids 1, 2 and 3 switch, in order, at the predetermined times.
  - Bin entrance switching solenoid 1 (SD1) activates for the predetermined time.
  - Bin entrance switching solenoid 2 (SD2) activates for the predetermined time.
  - Bin entrance switching solenoid 3 (SD3) activates for the predetermined time.
  - All bin entrance switching solenoids deactivate.
  - The operation is finished.

# Troubleshooting

## 6. Jam display

### 6.1 Misfeed display

- When misfeed occurs, message, misfeed location “Blinking” and paper location “Lighting” are displayed on the touch panel of the main body.

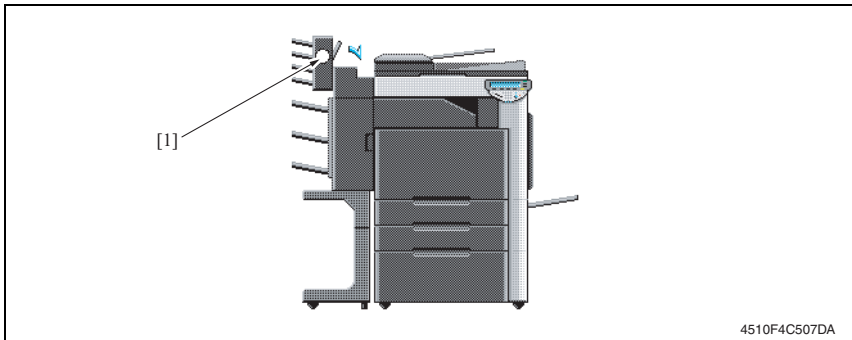

4510F4C507DA

Display	Code	Misfeed location	Misfeed access location	Action
[1]	7290	Vertical transport section	Right door	<a href="#">P.14</a>

#### 6.1.1 Misfeed display resetting procedure

- Open the corresponding door, clear the sheet of paper misfed, and close the door.

## 6.2 Sensor layout

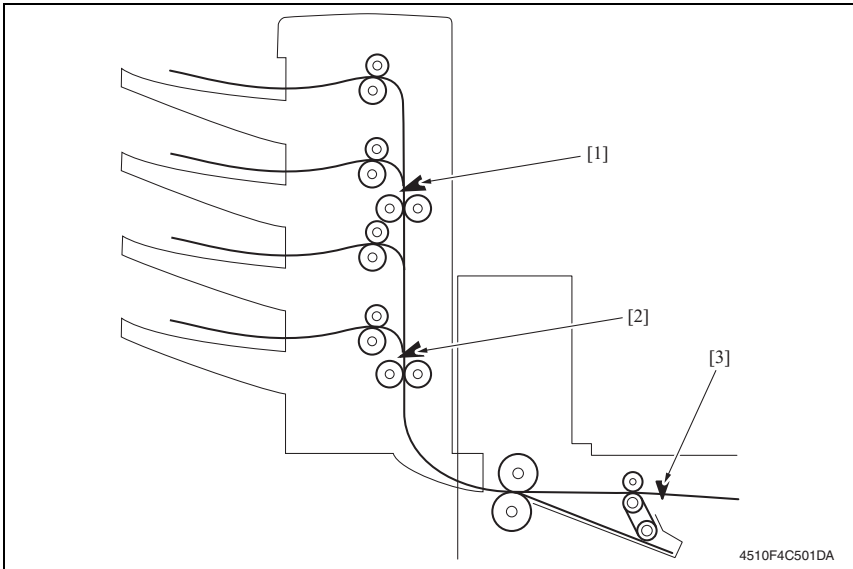

- |                            |      |
|----------------------------|------|
| [1] Upper transport sensor | PS9  |
| [2] Lower transport sensor | PS10 |
| [3] Transport sensor       | PS2  |

### 6.3 Solution

#### 6.3.1 Initial check items

- When a paper misfeed occurs, first perform the following initial check items.

Check Item	Action
Does the paper meet product specifications?	Change the paper.
Is paper curled, wavy, or damp?	See "Solution when paper curl occurs" on P.13.
Is a foreign object present along the paper path, or is the paper path deformed or worn?	Clean or change the paper path.
Are the rolls/rollers dirty, deformed, or worn?	Clean or change the defective roll/roller.
Are the edge guide and trailing edge stop at the correct position to accommodate the paper?	Set as necessary.
Are the actuators found operational when checked for correct operation?	Correct or change the defective actuator.

#### 6.3.2 Solution when paper curl occurs

Step	Check items/actions	OK	—
1	Turn over the stacked paper in the paper tray.	OK	—
		NG	Go to step 2.
2	Does paper curl occur just after a warm-up has been completed or the sleep mode has been turned OFF?	YES	Go to step 3.
	Does paper curl occur under normal conditions (under conditions other than those mentioned above)?	YES	Go to step 5.
3	1. Call the Service Mode to the screen. 2. Select [System 1] → [Change Warm Up Time]. 3. Change the setting to [Mode3]. See P.393 of the main body service manual.	OK	—
		NG	Go to step 4.
4	1. Call the Service Mode to the screen. 2. Select [System 1] → [Change Warm Up Time]. 3. Change the setting to [Mode4]. See P.393 of the main body service manual.	—	—
5	1. Call the Service Mode to the screen. 2. Select [Machine] → [Fusing Temperature]. 3. Select a paper type. 4. Change the temperature of Heater Roller to [-10 °C]. See P.345 of the main body service manual.	OK	—
		NG	Go to step 6
6	1. Call the Service Mode to the screen. 2. Select [Machine] → [Fusing Temperature]. 3. Select a paper type. 4. Change the temperature of Heater Roller to [-20 °C]. See P.345 of the main body service manual.	—	—

### 6.3.3 Transport section misfeed

#### A. Detection timing

Type	Description
Transport section misfeed detection	The lower transport sensor (PS10) is not turned ON even after the set period of time has elapsed after the transport sensor (PS2) is turned ON by the paper.
	The upper transport sensor (PS9) is not turned ON even after the set period of time has elapsed after the lower transport sensor (PS10) is turned ON by the paper.
Detection of paper remaining in the transport section	The lower transport sensor (PS10) is turned ON when the power switch is set to ON, a door or cover is opened and closed, or a misfeed or malfunction is reset.
	The upper transport sensor (PS9) is turned ON when the power switch is set to ON, a door or cover is opened and closed, or a misfeed or malfunction is reset.

#### B. Action

Relevant electrical parts	
Transport sensor (PS2) Lower transport sensor (PS10) Upper transport sensor (PS9)	MT control board (MTCB)



Step	Action	WIRING DIAGRAM	
		Control signal	Location (Electrical components)
1	Initial checks	—	—
2	PS2 I/O check, sensor check	FSCB PJ19-14 (ON)	FS-519 C-7
3	PS10 I/O check, sensor check	MTCB CN102-8 (ON)	MT-502 B to C-4
4	PS9 I/O check, sensor check	MTCB CN101-8 (ON)	MT-502 B to C-3
5	MTCB replacement	—	—



KONICA MINOLTA

**SERVICE MANUAL**

FIELD SERVICE

---

# SD-505







# Revision history

After publication of this service manual, the parts and mechanism may be subject to change for improvement of their performance.

Therefore, the descriptions given in this service manual may not coincide with the actual machine.

When any change has been made to the descriptions in the service manual, a revised version will be issued with a revision mark added as required.

Revision mark:

- To indicate clearly a specific section revised within text,  is shown at the left margin of the corresponding revised section.  
The number inside  represents the number of times the revision has been made.
- To indicate clearly a specific page that contains a revision or revisions, the page number appearing at the left or right bottom of the specific page is marked with .  
The number inside  represents the number of times the revision has been made.

## NOTE

Revision marks shown in a page are restricted only to the latest ones with the old ones deleted.

- When a page revised in Ver. 2.0 has been changed in Ver. 3.0:  
The revision marks for Ver. 3.0 only are shown with those for Ver. 2.0 deleted.
- When a page revised in Ver. 2.0 has not been changed in Ver. 3.0:  
The revision marks for Ver. 2.0 are left as they are.

2008/01	2.0		Error correction
2007/07	1.0	—	Issue of the first edition
Date	Service manual Ver.	Revision mark	Descriptions of revision

# CONTENTS

## SD-505

### General

1. Product specification ..... 1

### Maintenance

2. Service tool ..... 3

2.1 CE tool list..... 3

3. Other ..... 4

3.1 Disassembly/adjustment prohibited items ..... 4

3.2 Disassembly/Assembly/Cleaning list (other parts)..... 5

3.2.1 Disassembly/Assembly parts list..... 5

3.2.2 Cleaning parts list ..... 5

3.3 Disassembly/Assembly procedure..... 5

3.3.1 Paper output tray/front cover..... 5

3.3.2 Rear cover..... 6

3.3.3 Upper cover..... 6

3.3.4 Saddle unit..... 7

3.3.5 Crease unit..... 9

3.3.6 Stapler unit..... 11

3.3.7 In & out guide motor..... 15

3.3.8 Crease roller ..... 17

3.4 Cleaning procedure ..... 24

3.4.1 Cleaning of the rollers and rolls ..... 24

### Adjustment/Setting

4. How to use the adjustment section ..... 25

5. Sensor check..... 26

5.1 Check procedure ..... 26

5.1.1 Sensor check screen..... 26

5.1.2 Sensor check list..... 27

6. Finisher operations..... 28

6.1 Entering Finisher Check ..... 28

6.2 Finisher Check modes ..... 29

6.3 Fold & Staple Pos. Adjustment ..... 30

6.4 Center Staple Position Adjustment ..... 32

7.	Mechanical adjustment .....	34
7.1	Fold Angle Adjustment .....	34
7.2	Center Staple Angle Adjustment .....	35

## Troubleshooting

8.	Jam display .....	37
8.1	Misfeed display .....	37
8.2	Sensor layout .....	37
8.3	Solution .....	38
8.3.1	Initial check items .....	38
8.3.2	Solution when paper curl occurs.....	38
8.3.3	Paper bundle exit misfeed.....	39
8.3.4	Staple unit 1 misfeed/Staple unit 2 misfeed.....	40
8.3.5	Creasing section misfeed.....	41
9.	Malfunction code .....	42
9.1	Trouble code .....	42
9.2	Solution .....	43
9.2.1	C11A2: Saddle exit roller pressure/retraction failure .....	43
9.2.2	C11A4: Saddle exit motor failure .....	43
9.2.3	C11A5: Saddle in & out guide motor failure .....	44
9.2.4	C11A6: Saddle layable guide drive failure .....	44
9.2.5	C11B5: Side staple 1 drive failure.....	45
9.2.6	C11B6: Side staple 2 drive failure.....	45
9.2.7	C11D0: Crease motor drive failure .....	45

# General

## 1. Product specification

### A. Type

Name	Saddle sticher SD-505
Type	Built into the finisher
Installation	Screwed to the finisher
Document alignment	Center
Stapling function	Center parallel two points No. of sheets to be stapled together: 2 to 15

### B. Paper

Type	Plain paper	60 g/m <sup>2</sup> to 90 g/m <sup>2</sup>
	Recycled paper	16 to 24 lb
	Thick paper	91 g/m <sup>2</sup> to 209 g/m <sup>2</sup> 24.25 to 55.5 lb
Size	B5S to A3 8-1/2 x 11S to 11 x 17	
Capacity	200 sheets or 20 copies	

### C. Machine specifications

Power requirements		DC 24 V (supplied from the finisher) DC 5 V
Max. power consumption		9.5 W or less
Dimensions	Crease unit	48 mm (W) x 399 mm (D) x 121 mm (H) 2 inch (W) x 15.75 inch (D) x 4.75 inch (H)
	Saddle unit	445 mm (W) x 478 mm (D) x 203 mm (H) 17.5 inch (W) x 18.75 inch (D) x 8 inch (H) 576 mm (W) x 478 mm (D) x 281 mm (H) *1 22.75 inch (W) x 18.75 inch (D) x 11 inch (H) *1
Weight	Crease unit	1.9 kg (0.5 lb)
	Saddle unit	7.4 kg (2.0 lb)

\*1: Size when the paper output tray is pulled out

### D. Operating environment

- Conforms to the operating environment of the main body.

### E. Consumables

- Staples 2000 (MS-2C) x 2

### NOTE

- These specifications are subject to change without notice.

Blank Page

# Maintenance

## 2. Service tool

### 2.1 CE tool list

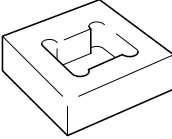
Tool name	Shape	Personnel	Parts No.	Remarks
Stapler unit positioning jig		1	4511-7901-01	

## 3. Other

### 3.1 Disassembly/adjustment prohibited items

#### A. Paint-locked screws

##### NOTE

- To prevent loose screws, a screw lock in blue or green series color is applied to the screws.
- The screw lock is applied to the screws that may get loose due to the vibrations and loads created by the use of machine or due to the vibrations created during transportation.
- If the screw lock coated screws are loosened or removed, be sure to apply a screw lock after the screws are tightened.

#### B. Red-painted screws

##### NOTE

- The screws which are difficult to be adjusted in the field are painted in red in order to prevent them from being removed by mistake.
- Do not remove or loosen any of the red-painted screws in the field. It should also be noted that, when two or more screws are used for a single part, only one representative screw may be marked with the red paint.

#### C. Variable resistors on board

##### NOTE

- Do not turn the variable resistors on boards for which no adjusting instructions are given in Adjustment/Setting.

#### D. Removal of PWBs

##### CAUTION

- When removing a circuit board or other electrical component, refer to “Handling of PWBs” and follow the corresponding removal procedures.
- The removal procedures given in the following omit the removal of connectors and screws securing the circuit board support or circuit board.
- Where it is absolutely necessary to touch the ICs and other electrical components on the board, be sure to ground your body.

### 3.2 Disassembly/Assembly/Cleaning list (other parts)

#### 3.2.1 Disassembly/Assembly parts list

No.	Section	Part name	Ref. page
1	Exterior parts	Paper output tray	P.5
2		Front cover	P.5
3		Upper cover	P.6
4		Rear cover	P.6
5	Units	Saddle unit	P.7
6		Crease unit	P.9
7		Stapler unit	P.11
8	Others	In & out guide drive motor	P.15
9		Crease roller	P.17

#### 3.2.2 Cleaning parts list

No.	Section	Part name	Ref. page
1	Exit section Transport section	Rollers and rolls	P.24

### 3.3 Disassembly/Assembly procedure

#### 3.3.1 Paper output tray/front cover

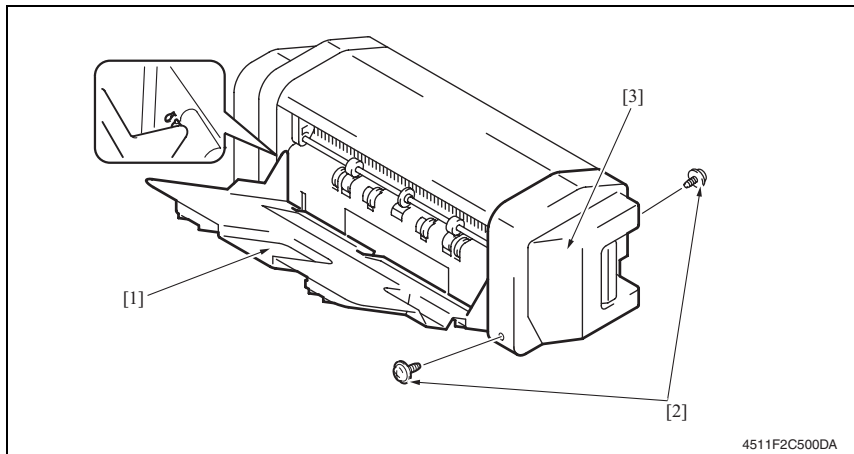

1. Align the cutout and remove the paper output tray [1].
2. Remove two screws [2], and remove the front cover [3].



### 3.3.2 Rear cover

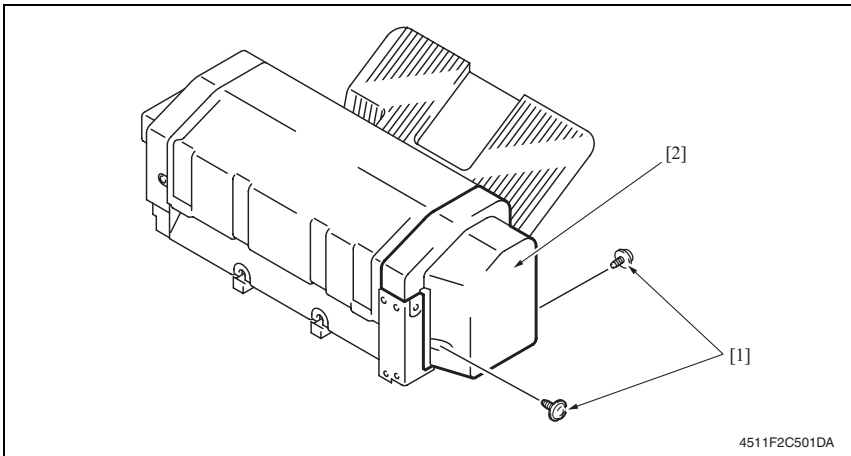

1. Remove two screws [1], and remove the rear cover [2].

### 3.3.3 Upper cover

1. Remove the front cover.  
[See P.5](#)
2. Remove the rear cover.  
[See P.6](#)

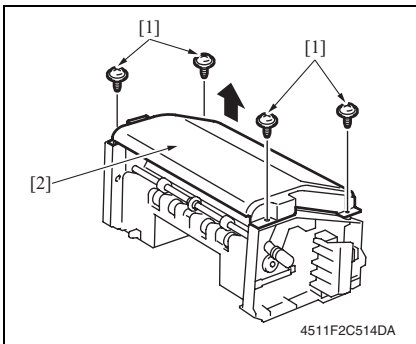

3. Remove four screws [1], and remove the upper cover [2].

### 3.3.4 Saddle unit

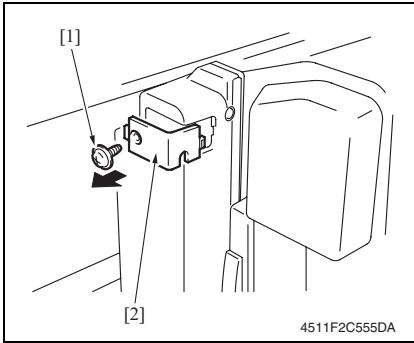

1. Remove the screw [1], and remove the connector cover [2].

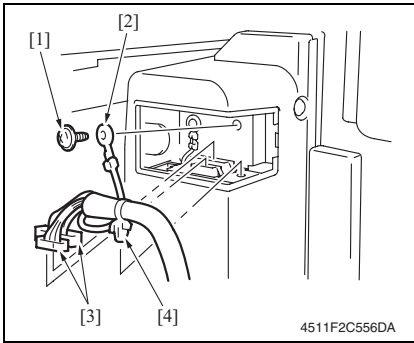

2. Remove the screw [1], and remove the ground wire [2].
3. Disconnect two connectors [3].
4. Remove the snap band [4].

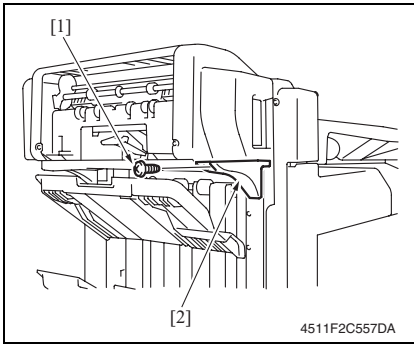

5. Remove the screw [1], and remove the mounting bracket [2].

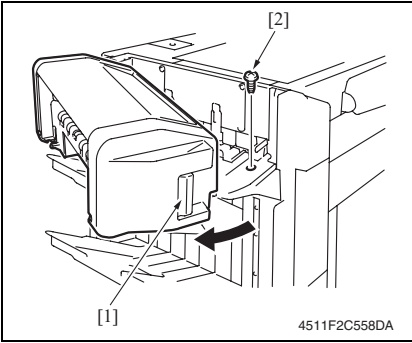

4511F2C558DA

- 6. Pull the lock release lever [1], and open the saddle unit.
- 7. Remove the screw [2].

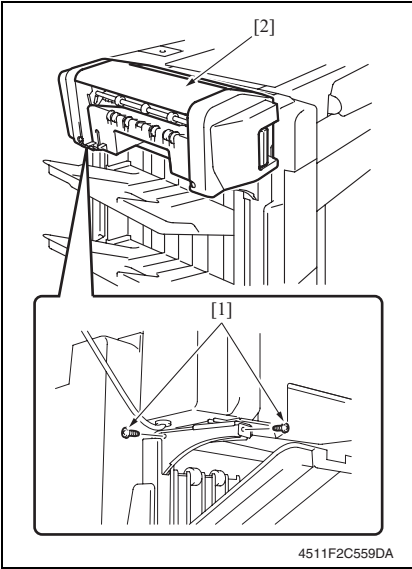

4511F2C559DA

- 8. Remove two screws [1], and remove the saddle unit [2].

### 3.3.5 Crease unit

1. Remove the saddle unit.  
See P.7
2. Remove the finisher unit.  
See P.28 of the FS-519/PK-515/OT-602 service manual.

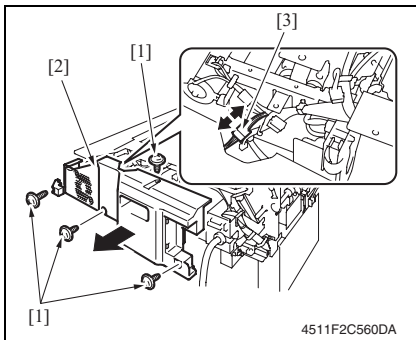

3. Remove four screws [1] and remove the finisher unit rear cover [2].
4. Disconnect the connector [3].

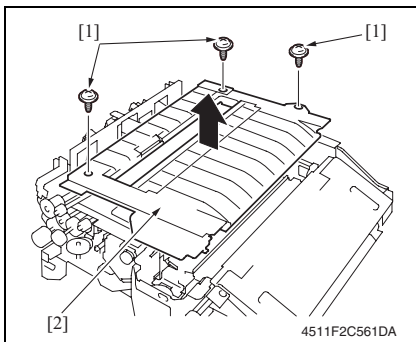

5. Remove three screws [1] and remove the finisher unit upper cover [2].

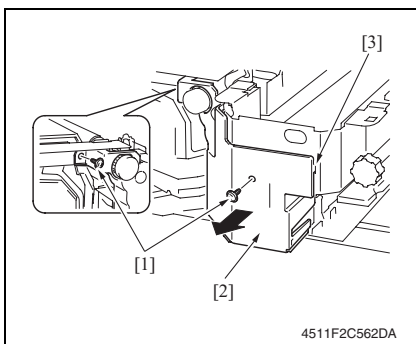

6. Remove two screws [1] and remove the finisher unit right front cover [2].

**NOTE**

- At reinstallation, first fit the tab [3] into position.

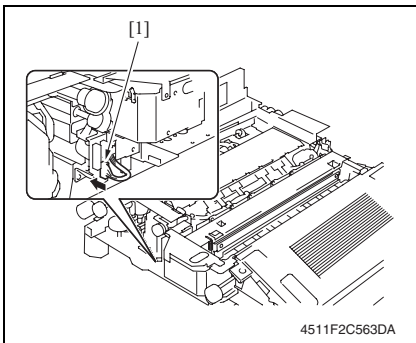

4511F2C563DA

7. Disconnect the connector [1].

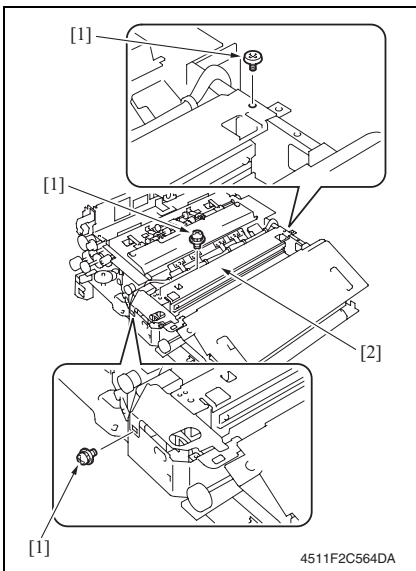

4511F2C564DA

8. Remove three screws [1], and remove the crease unit [2].

**NOTE**

- When the punch kit is mounted, remove the punch kit first.

### 3.3.6 Stapler unit

1. Remove the saddle unit.  
See P.7
2. Remove the paper output tray.  
See P.5
3. Remove the front cover.  
See P.5
4. Remove the rear cover.  
See P.6
5. Remove the upper cover.  
See P.6

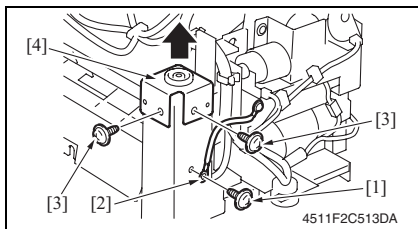

6. Remove the screw [1], and remove the ground wire [2].
7. Remove two screws [3], and remove the holder [4].

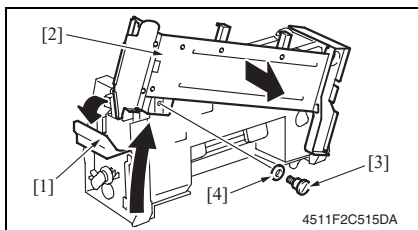

8. Release the lock release lever [1], and slide the saddle unit mounting plate [2].
9. Remove the shoulder screw [3] and the washer [4], and remove the saddle unit mounting plate [2].

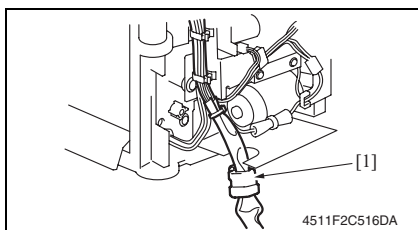

10. Remove the harness clamp [1] from the metal bracket.

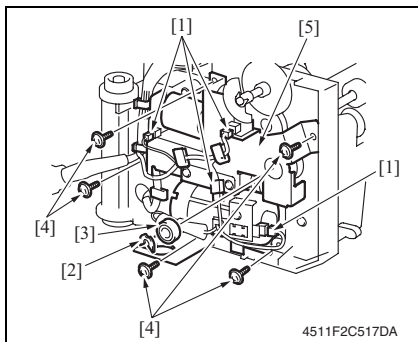

11. Remove the harness from the wire saddle.
12. Disconnect four connectors [1].
13. Remove the C-ring [2], and remove the bearing [3].
14. Remove five screws [4], and remove the drive unit [5].

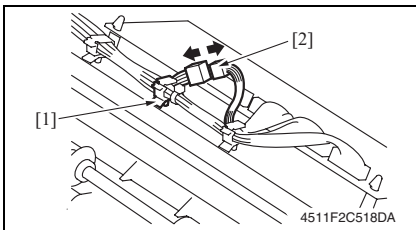

15. Remove the wire saddle [1], and disconnect the connector [2].

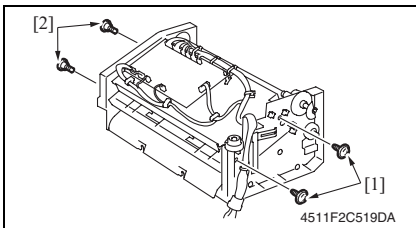

16. Remove two screws [1] and two shoulder screws [2].

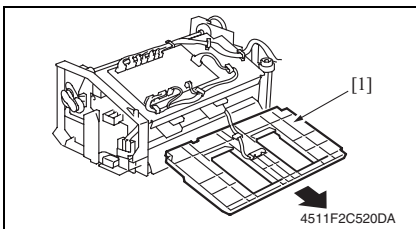

17. Remove the processing tray [1].

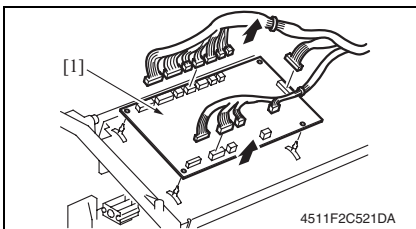

18. Disconnect all the connectors on the SD control board.

19. Remove the board support, and then remove the SD control board [1].

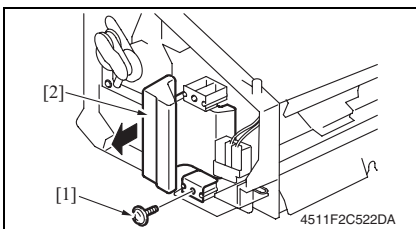

20. Remove the screw [1], and remove the lock release lever [2].

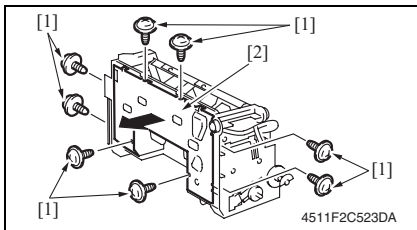

21. Remove eight screws [1], and remove the lower cover [2].

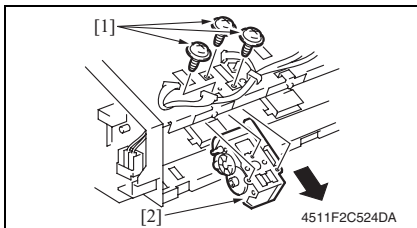

22. Remove the wire saddle and disconnect the connector.

23. Remove three screws [1], and remove the clincher 1 [2].

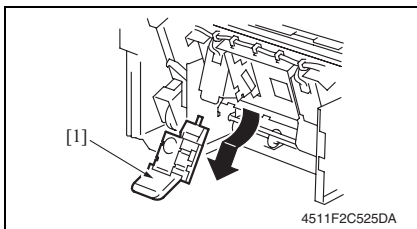

24. Remove the staple cartridge 1 [1].

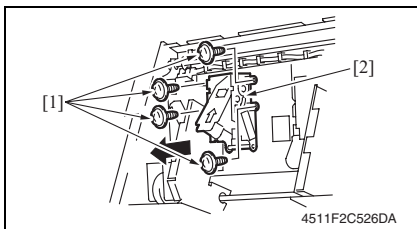

25. Remove four screws [1], and remove the stapler 1 [2].

**NOTE**

- To replace clincher 2 and stapler 2, repeat steps 22 to 25.



**Precaution for clincher reinstallation**

- When the clincher is installed, the position of the stapler and the clincher will be misaligned. Be sure to perform the following adjustment.

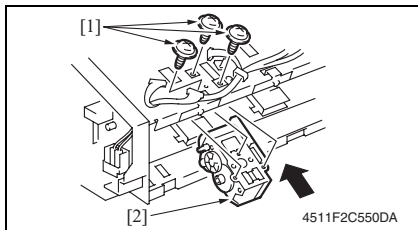

1. Use three screws [1] to temporary fix the clincher [2].

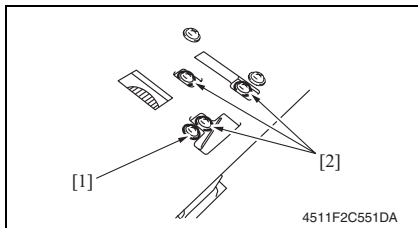

2. Loosen the screw [1] of the stopper.
3. Loosen three screws [2] of the clincher.

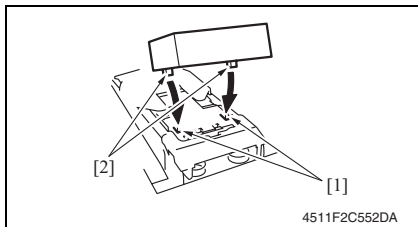

4. Aligning the protrusions of the jig [2] with the recesses in the stapler [1], fit the jig to the stapler.

**NOTE**

- Make sure that the protrusions of the jig properly rest in the recesses.

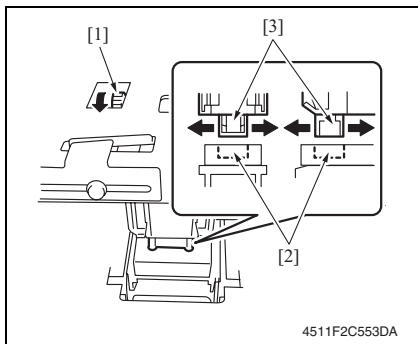

5. Turn the gear [1] of the clincher and then slide the clincher assy so that the protrusion of the clincher [3] fits into the recess in the jig [2].

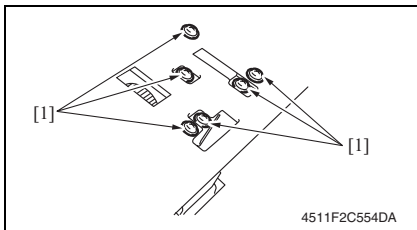

6. Tighten six screws [1].

**NOTE**

- Turn the gear again and check to see that the protrusion of the clincher smoothly fits into the recess in the jig.

7. Turn the gear and remove the jig.

**3.3.7 In & out guide motor**

1. Remove the saddle unit.  
See P.7
2. Remove the paper output tray.  
See P.5
3. Remove the front cover.  
See P.5
4. Remove the rear cover.  
See P.6
5. Remove the upper cover.  
See P.6

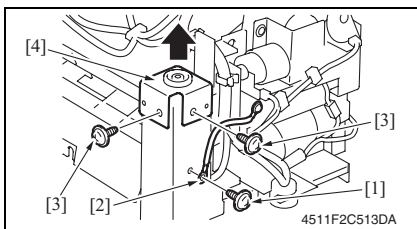

6. Remove the screw [1], and remove the ground wire [2].
7. Remove two screws [3], and remove the holder [4].

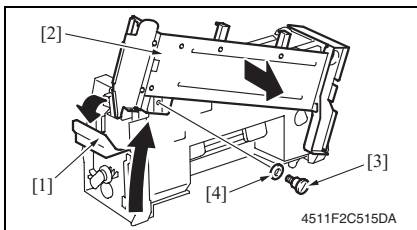

8. Release the lock release lever [1], and slide the saddle unit mounting plate [2].
9. Remove the shoulder screw [3] and the washer [4], and remove the saddle unit mounting plate [2].

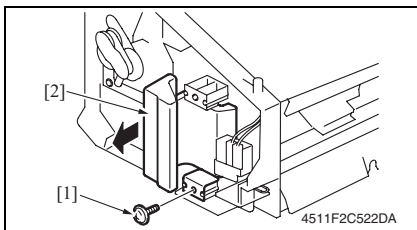

10. Remove the screw [1], and remove the lock release lever [2].

SD-505

Maintenance

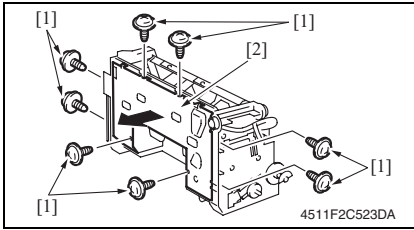

11. Remove eight screws [1], and remove the lower cover [2].

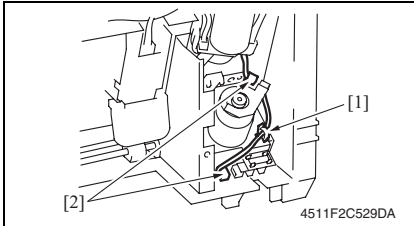

12. Remove the wire saddle [1], and disconnect two connectors [2].

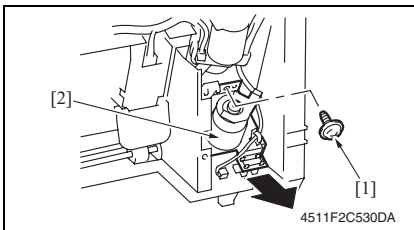

13. Remove the screw [1], and remove the in & out guide motor assembly [2].

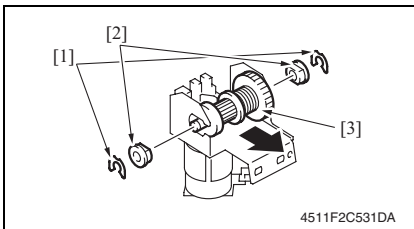

14. Remove two C-rings [1].  
15. Remove two bushings [2], and remove the clutch gear assembly [3].

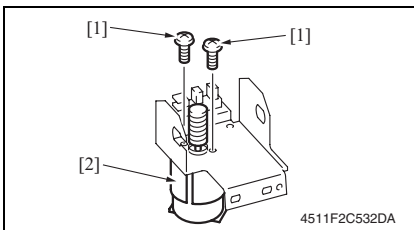

16. Remove two screws [1], and remove the in & out guide motor [2].

### Precaution for in & out guide motor reinstallation

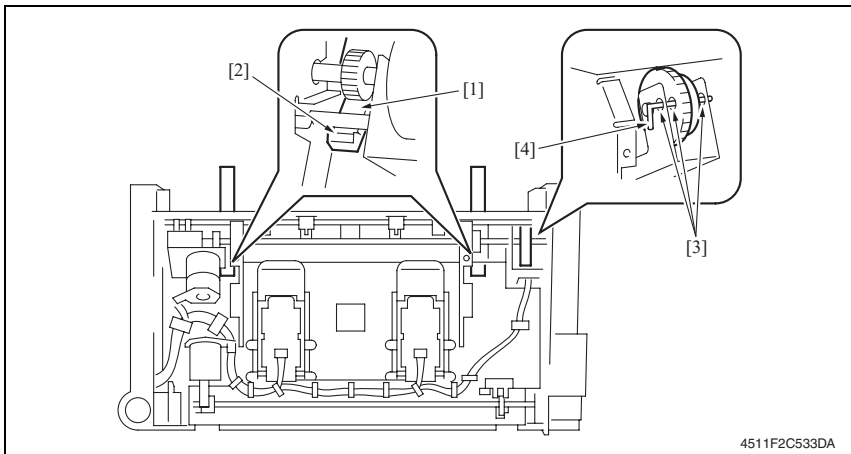

1. Press the two in & out guides [1] in and check that they touch the stopper [2] simultaneously.
2. Check that pins [4] can be inserted through the positioning holes [3] (3 holes) of the in & out guide sensor assy.
3. Use two screws to secure the in & out guide motor.

### 3.3.8 Crease roller

1. Remove the crease unit.  
[See P.9](#)

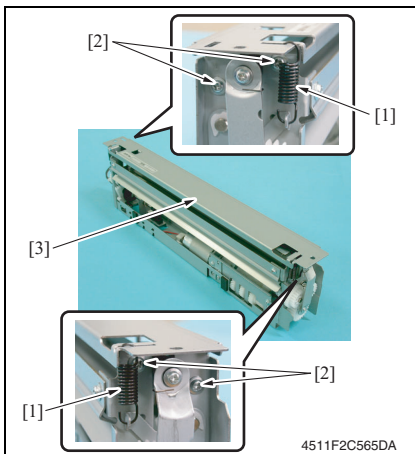

2. Remove two springs [1] and four screws [2], and remove the upper plate [3].

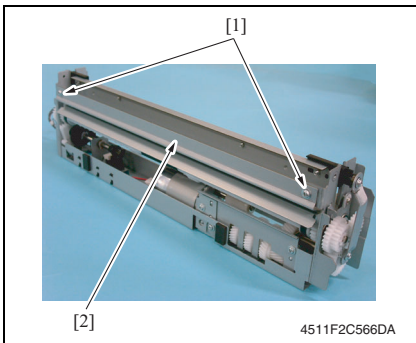

3. Remove two screws [1], and remove the guide plate [2].

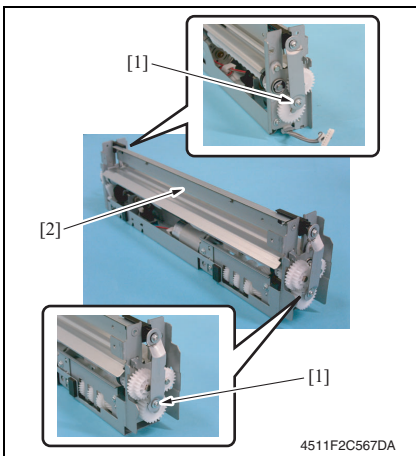

4. Remove two screws [1], and remove the chopper assy [2].

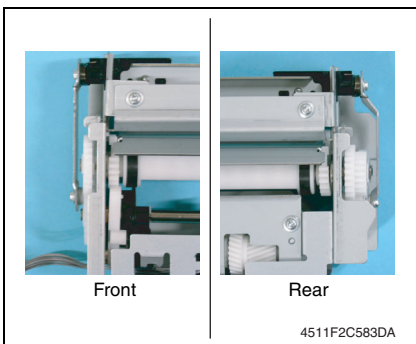

**NOTE**

- Install the chopper assy in the direction shown in the left figure.

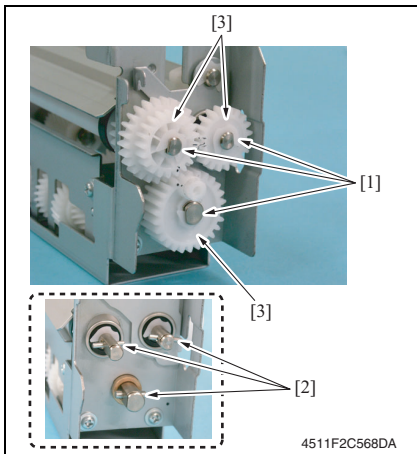

5. Remove three C-rings [1] and three pins [2], and remove three gears [3].

**NOTE**

- Use care not to lose the pin.

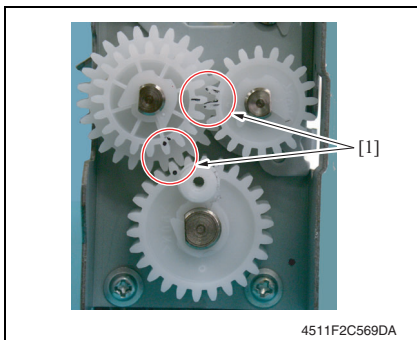

**NOTE**

- Install the gear so that the mark [1] is aligned to the position shown in the left figure.

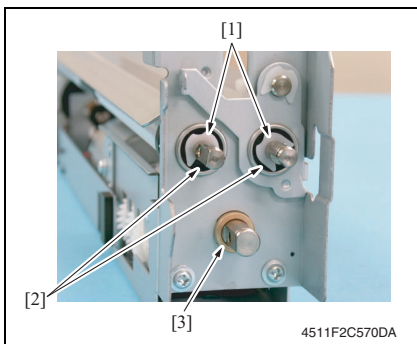

6. Remove two C-rings [1], and remove two bearings [2].
7. Remove the bushing [3].

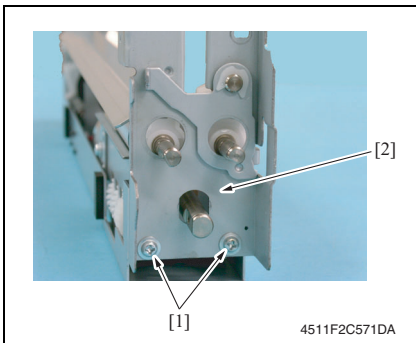

- 8. Remove two screws [1], and remove the rear holder [2].

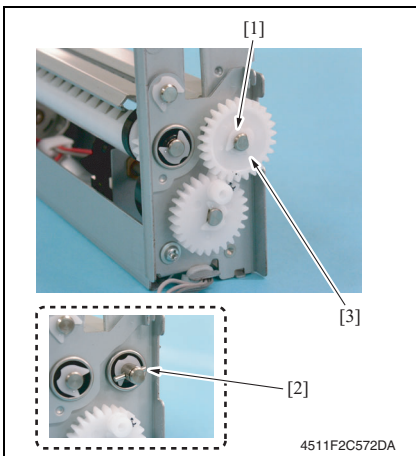

- 9. Remove the C-ring [1] and the pin [2], and remove the gear [3].

**NOTE**

- Use care not to lose the pin.

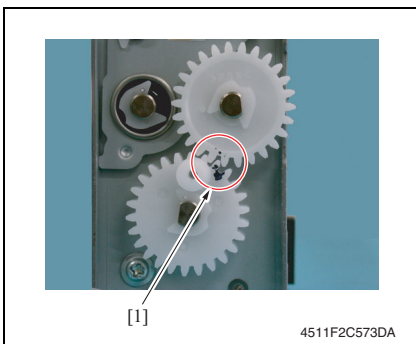

**NOTE**

- Install the gear so that the mark [1] is aligned to the position shown in the left figure.

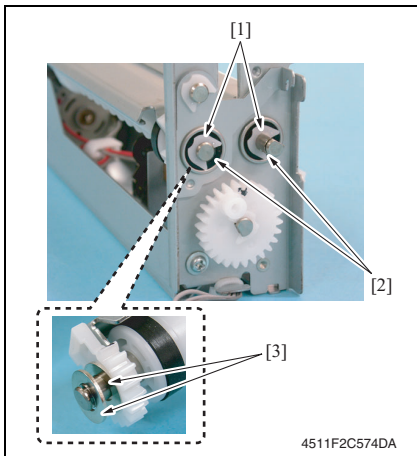

10. Remove two C-rings [1], two bearings [2] and two washers [3].

**NOTE**

- Use care not to lose the washer.

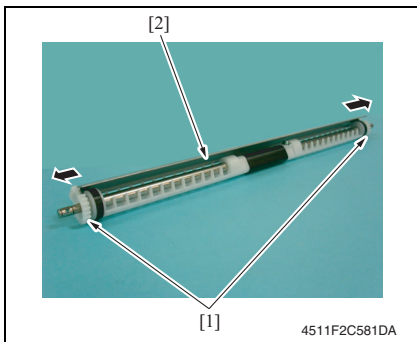

11. Remove two gears [1] of crease roller 1 assy, and remove the guide plate [2].

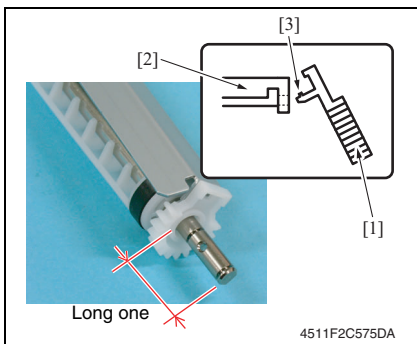

**NOTE**

- When installing the gear [1] to the guide plate [2], insert the gear [1] at an angle and use care not to break the tabs [3].
- Install the guide plate as shown on the left.



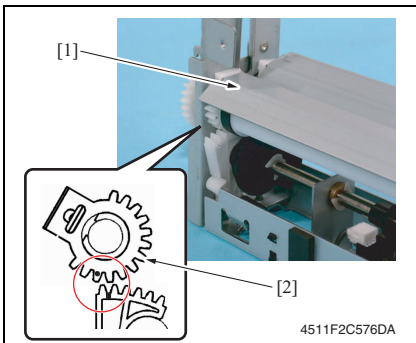

**NOTE**

- When mounting the crease roller 1 assy [1], mount it so that the tally mark on the gear [2] for the crease roller 1 and the tally mark on the gear below will be next to each other with the one on the gear [2] being outer side.

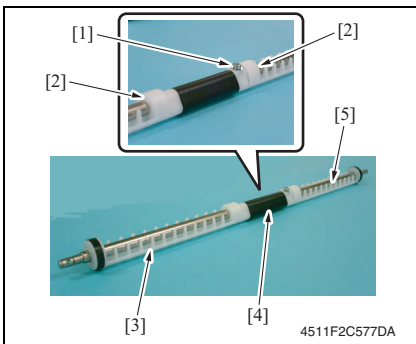

12. Remove the screw [1].
13. Remove two C-rings [2] and remove the crease roller A [3], B [4] and C [5].

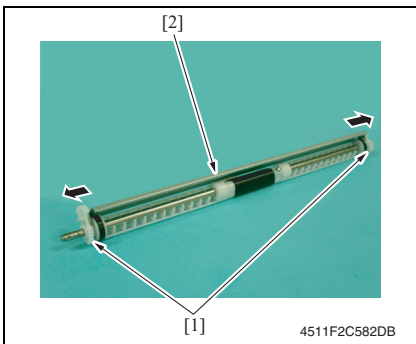

14. Remove two gears [1] of crease roller 2 assy, and remove the guide plate [2].

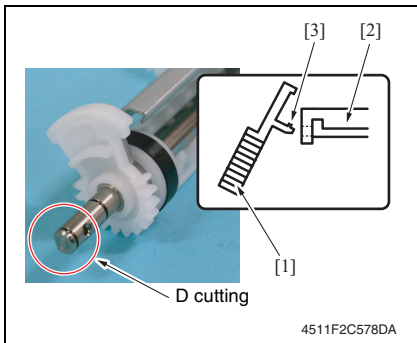

**NOTE**

- When installing the gear [1] to the guide plate [2], insert the gear [1] at an angle and use care not to break the tabs [3].
- Install the gear and guide plate as shown on the left.

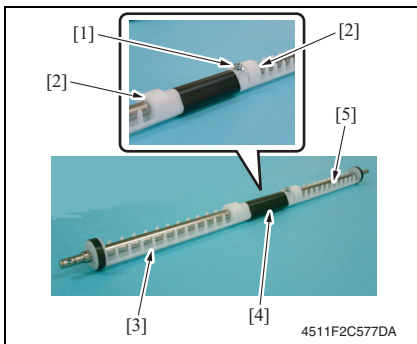

15. Remove the screw [1].
16. Remove two C-rings [2] and remove the crease roller A [3], B [4] and C [5].

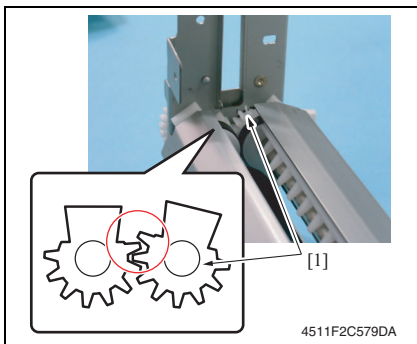

**NOTE**

- When mounting the crease roller assy 2, mount it so that the gear [1] for the crease roller 2 assy will be over the gear for the crease roller 1 by one tooth.

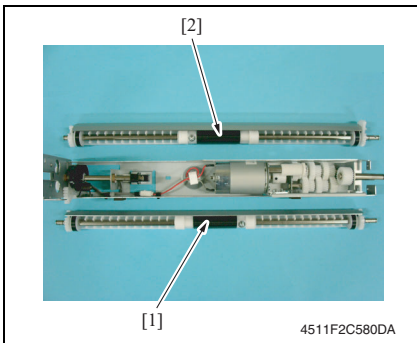

**NOTE**

- Use care to mount the crease roller assy 1 [1] and 2 [2] in the proper directions.

### 3.4 Cleaning procedure

**NOTE**

- The alcohol described in the cleaning procedure of maintenance represents the isopropyl alcohol.

#### 3.4.1 Cleaning of the rollers and rolls

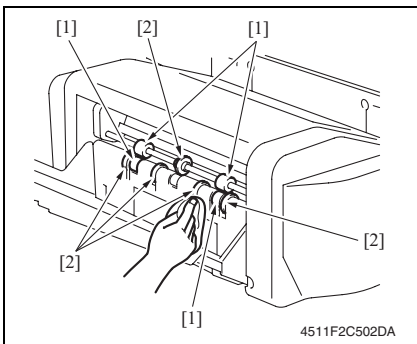

7. Using a cleaning pad dampened with alcohol, wipe the roller [1] and roll [2].

2. Remove the crease unit.

[See P.9](#)

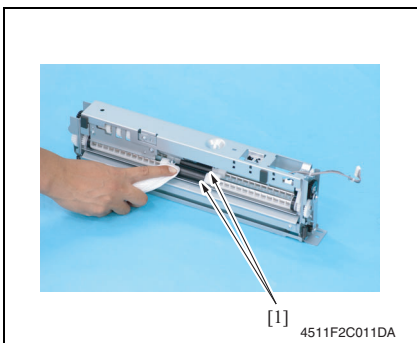

3. Using a cleaning pad dampened with alcohol, wipe the roller [1].

# Adjustment/Setting

## 4. How to use the adjustment section

- “Adjustment/Setting” contains detailed information on the adjustment items and procedures for this machine.
- Throughout this “Adjustment/Setting,” the default settings are indicated by “ ”.

### Advance checks

Before attempting to solve the customer problem, the following advance checks must be made. Check to see if:

- The power supply voltage meets the specifications.
- The power supply is properly grounded.
- The machine shares the power supply with any other machine that draws large current intermittently (e.g., elevator and air conditioner that generate electric noise).
- The installation site is environmentally appropriate: high temperature, high humidity, direct sunlight, ventilation, etc.; levelness of the installation site.
- The original has a problem that may cause a defective image.
- The density is properly selected.
- The original glass, slit glass, or related part is dirty.
- Correct paper is being used for printing.
- The units, parts, and supplies used for printing (developer, PC drum, etc.) are properly replenished and replaced when they reach the end of their useful service life.
- Toner is not running out.

### CAUTION

- **To unplug the power cord of the machine before starting the service job procedures.**
- **If it is unavoidably necessary to service the machine with its power turned ON, use utmost care not to be caught in the scanner cables or gears of the exposure unit.**
- **Special care should be used when handling the fusing unit which can be extremely hot.**
- **The developing unit has a strong magnetic field. Keep watches and measuring instruments away from it.**
- **Take care not to damage the PC drum with a tool or similar device.**
- **Do not touch IC pins with bare hands.**

# 5. Sensor check

## 5.1 Check procedure

### A. Procedure

1. Display the Service Mode screen.  
[See P.338 of the main body service manual.](#)
2. Touch [State Confirmation].
3. Touch [Sensor Check].
4. Touch three times [▼].

### 5.1.1 Sensor check screen

- This is only typical screen which may be different from what are shown on each individual main body.

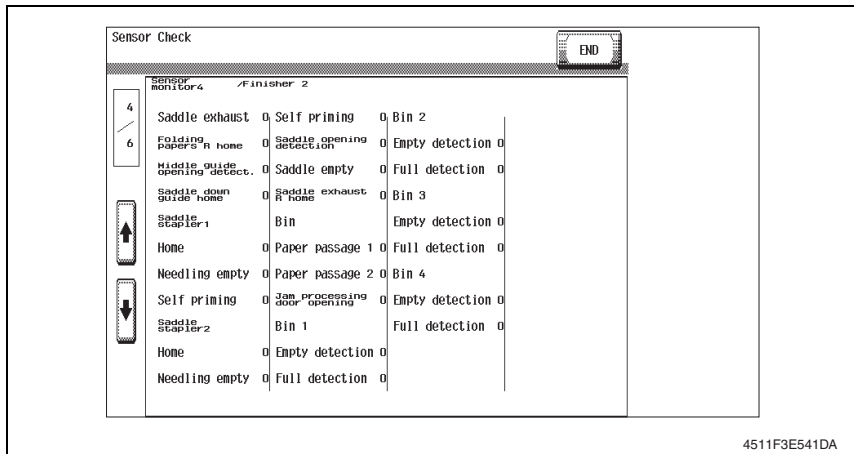

**5.1.2 Sensor check list**

**A. Sensors 4**

Symbol	Panel display	Part/Signal name	Operation characteristics/Panel display	
			1	0
PS20	Saddle exit	Saddle exit sensor	Paper present	Paper not present
PS22	Folding R home	Crease roller home position sensor	Paper present	Paper not present
SW5	Middle guide	Middle guide switch	Open	Closed
PS24	Saddle guide	Layable guide home sensor	Blocked	Unblocked
—	Saddle stapler 1			
—	Home	Staple Home Position Sensor 1	Blocked	Unblocked
—	Staple empty	Staple Empty Detection Sensor 1	Blocked	Unblocked
—	Self priming	Self-Priming Sensor 1	Blocked	Unblocked
—	Saddle stapler 2			
—	Home	Staple Home Position Sensor 2	Blocked	Unblocked
—	Staple empty	Staple Empty Detection Sensor 2	Blocked	Unblocked
—	Self priming	Self-Priming Sensor 2	Blocked	Unblocked
SW4	Saddle	Saddle opening switch	Open	Closed
PS21	Saddle empty	Saddle tray empty sensor	Paper present	Paper not present
PS18	Home (Saddle exit)	Saddle exit roller home position sensor	Paper present	Paper not present

Sensors monitor4

SD-505

Adjustment / Setting

## 6. Finisher operations

### 6.1 Entering Finisher Check

1. Display the Service Mode screen.  
[See P.338 of the main body service manual.](#)
2. Touch [Finisher].
3. Touch [CB-FN adjustment].
4. Touch [Finisher Check].
5. Touch the item one wants.

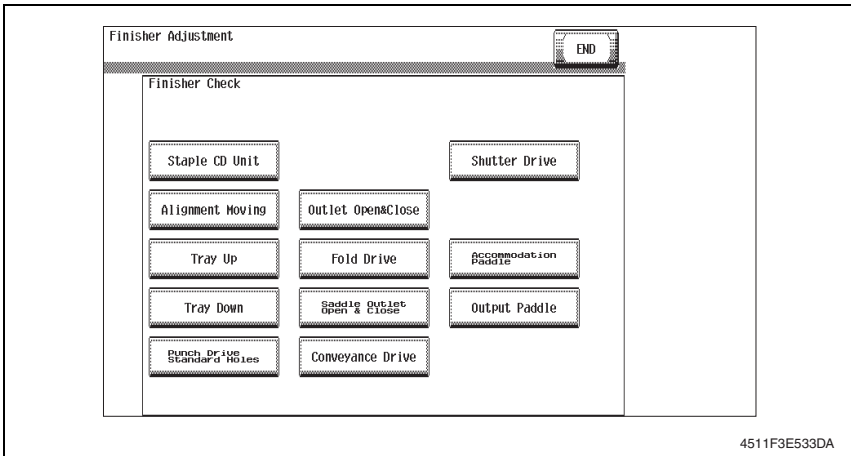

## 6.2 Finisher Check modes



### A. Fold Drive

- Performs the creasing drive once.
  - Raises the layable guide.
  - Stops after the predetermined time.
  - Lowers the layable guide.
  - The operation is finished.



### B. Saddle Outlet Open&Close

- Opens the saddle exit after the saddle exit is opened and closed.
  - Stops after the predetermined time.
  - The saddle exit closes.
  - The saddle in & out guide advances.
  - Stops after the predetermined time.
  - The saddle in & out guide retracts.
  - The operation is finished.



### C. Conveyance Drive

- Transport drive is performed for the predetermined time. (Performs the same transport drive as the pre-drive with the high speed of the connected copier.)
  - Drives the entrance motor (M1).
  - Drives the transport motor/1 (M2).
  - Drives the transport motor/2 (M3).
  - Drives the exit motor (M4).
  - The operation is finished.
- If the mail bin kit MT-502 is installed, the mail bins are also driven.
- If the saddle kit SD-505 is also installed, the saddle transport motor (M8) is also driven.





### 6.3 Fold & Staple Pos. Adjustment

#### NOTE

Make this adjustment after any of the following procedures has been performed.

- When the crease unit has been replaced.
- When a deviation occurs in the crease.
- When fold angle adjustment has been made.

1. Make a copy in the crease mode. (A3 size)

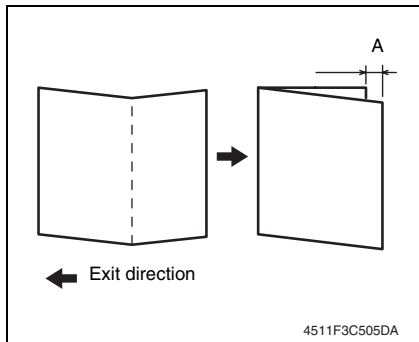

2. Fold the copy fed out along the crease.
3. Check the crease for deviation (Measure width A).  
Specification:  $0 \pm 1.5$  mm
4. When the width A does not fall within the specified value, conduct the following adjustment.

5. Display the Service Mode screen.  
[See P.338 of the main body service manual.](#)
6. Touch [Finisher].
7. Touch [CB-FN adjustment].
8. Touch [Fold & Staple Pos.Adjustment].
9. Touch [Fold Position Adjustment].
10. Touch [A3] and then touch [Normal Paper].

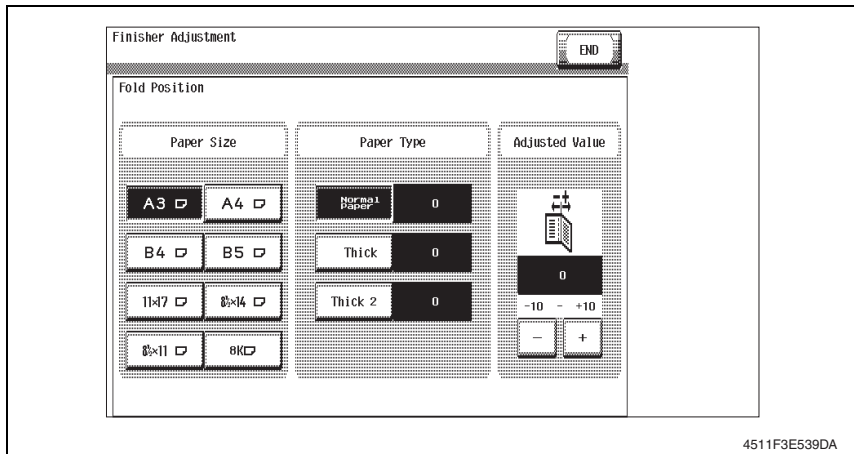

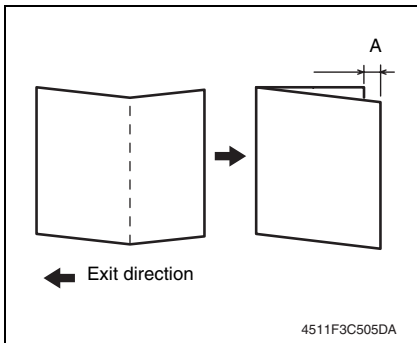

- If the fold is offset as shown on the left.  
11. Touch [-] and set the appropriate numeric value.  
Adjustment range: 0 to -10  
(1 increment 0.5 mm)

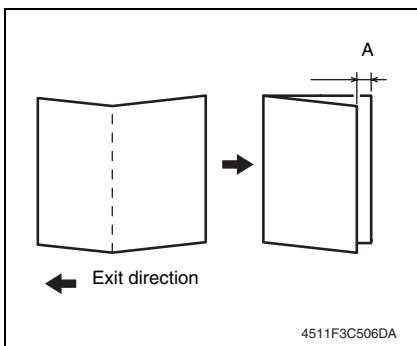

- If the fold is offset as shown on the left.  
12. Touch [+] and set the appropriate numeric value.  
Adjustment range: 0 to +10  
(1 increment 0.5 mm)

13. Touch [END].
14. Make another copy, and check the deviation.
15. Touch [Exit] on the Service Mode screen.
16. Turn OFF the main power switch, wait for 10 sec., then turn the switch ON.

### 6.4 Center Staple Position Adjustment

#### NOTE

Make this adjustment after any of the following procedures has been performed.

- When staple unit has been replaced.
- When center staple position is misaligned.
- When center staple angle adjustment has been made.

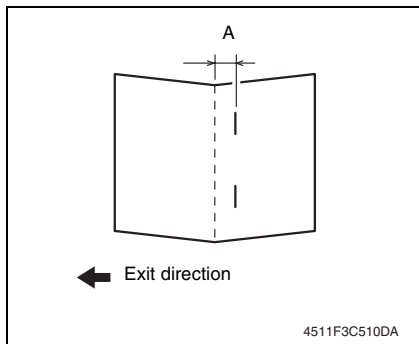

1. Load a five-page A4 document in the document feed tray.
2. Select the center staple mode and make a copy. (A3 Size)
3. Check the staple position for deviation from the crease (Measure width A).  
Specification:  $0 \pm 1.5 \text{ mm}$
4. When the width A does not fall within the specified value, conduct the following adjustment.

5. Display the Service Mode screen.  
[See P.338 of the main body service manual.](#)
6. Touch [Finisher].
7. Touch [CB-FN adjustment].
8. Touch [Fold & Staple Pos.Adjustment].
9. Touch [Center Staple Position].
10. Touch [A3] and then touch [Normal Paper].

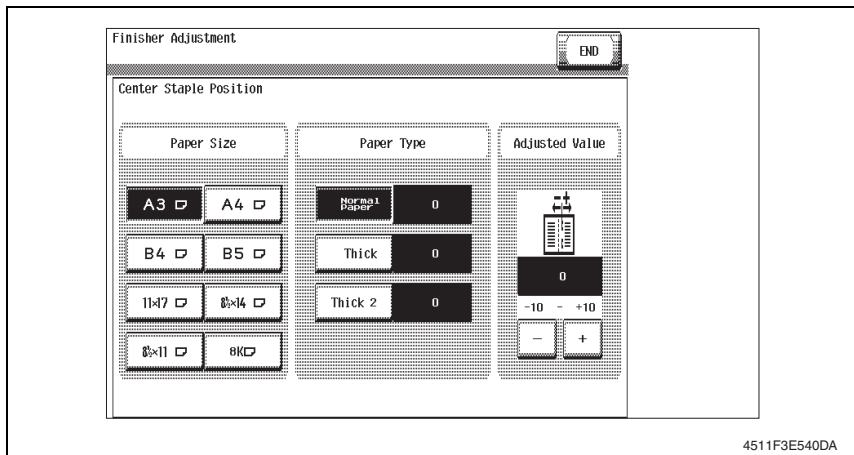

4511F3E540DA

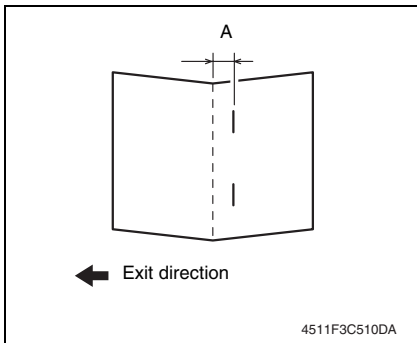

- If the fold is offset as shown on the left.  
11. Touch [-] and set the appropriate numeric value.  
Adjustment range: 0 to -10  
(1 increment 0.5 mm)

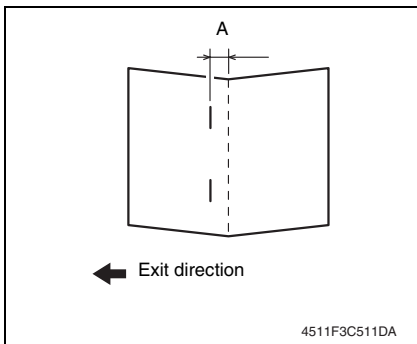

- If the fold is offset as shown on the left.  
12. Touch [+] and set the appropriate numeric value.  
Adjustment range: 0 to +10  
(1 increment 0.5 mm)

13. Touch [END].
14. Make another copy, and check the deviation.
15. Touch [Exit] on the Service Mode screen.
16. Turn OFF the main power switch, wait for 10 sec., then turn the switch ON.

# 7. Mechanical adjustment

## 7.1 Fold Angle Adjustment

### NOTE

Make this adjustment after any of the following procedures has been performed.

- When the crease unit has been replaced.
- When a slant occurs in the crease.

1. Make a copy in the crease mode. (A3 size)

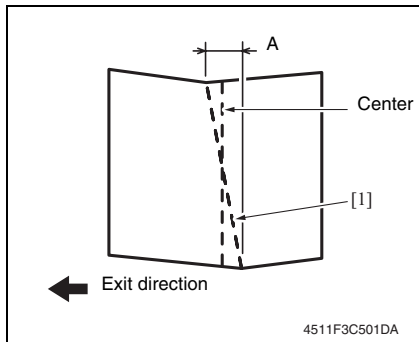

2. Fold the output paper along the crease [1].
3. Fold the output paper and half and measure the width A of the paper. Specification:  $0 \pm 1.5$  mm
4. If the fold position is slanted as shown on the left, make the following adjustment.

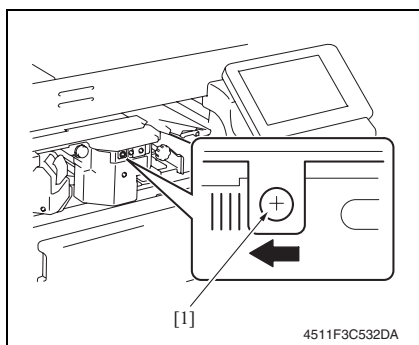

5. Open the front door, loosen the adjustment screw [1], and move the crease unit to the left to make the adjustment. Graduated in 1-mm divisions
  - If the fold position is slanted opposite to the figure of step 4, move the crease unit to the right to make the adjustment.
6. Make another copy and check the fold position.

## 7.2 Center Staple Angle Adjustment

### NOTE

Make this adjustment after any of the following procedures has been performed.

- When staple unit has been replaced.
- When a slant occurs in the position of the center staple.

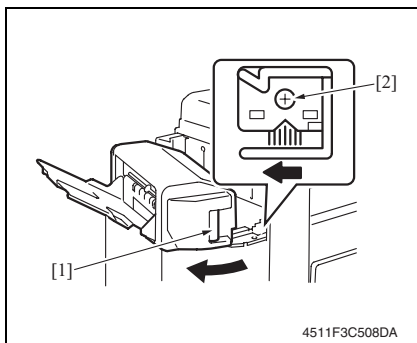
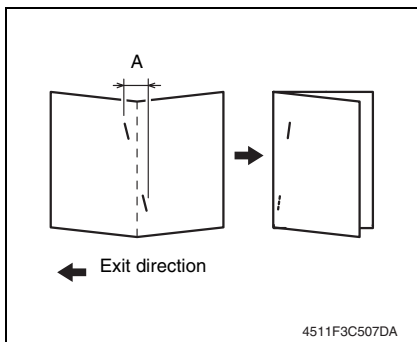

1. Load a five-page A4 document in the document feed tray.
  2. Select the center staple mode and make a copy. (A3 Size)
  3. Check the staple position for deviation from the crease (Measure width A).  
Specification:  $0 \pm 1.5$  mm
  4. If the staple position is slanted as shown on the left, make the following adjustment.
  5. Release the lock release lever [1] of the saddle unit.
  6. Loosen the adjustment screw [2] and move the lock lever to the left to make the adjustment.
- If the staple position is slanted opposite to the figure of step 2, move the lock lever to the right to make the adjustment.

7. Make another copy and check the staple position.

Blank Page

# Troubleshooting

## 8. Jam display

### 8.1 Misfeed display

- When misfeed occurs, message, misfeed location “Blinking” and paper location “Lighting” are displayed on the touch panel of the main body.

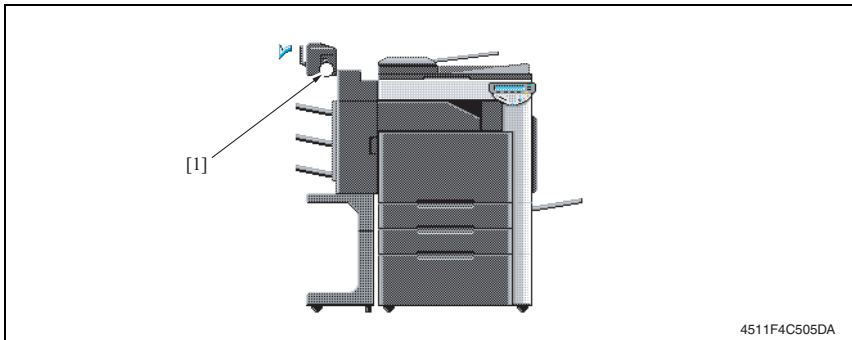

4511F4C505DA

Display	Code	Misfeed location	Misfeed processing location	Action
[1]	7221	Paper bundle exit misfeed	Front door	<a href="#">P.39</a>
	7285	Staple unit 1 misfeed	Saddle cover	<a href="#">P.40</a>
	7284	Staple unit 2 misfeed	Saddle cover	
	7225	Creasing section misfeed	Front door	<a href="#">P.41</a>

### 8.2 Sensor layout

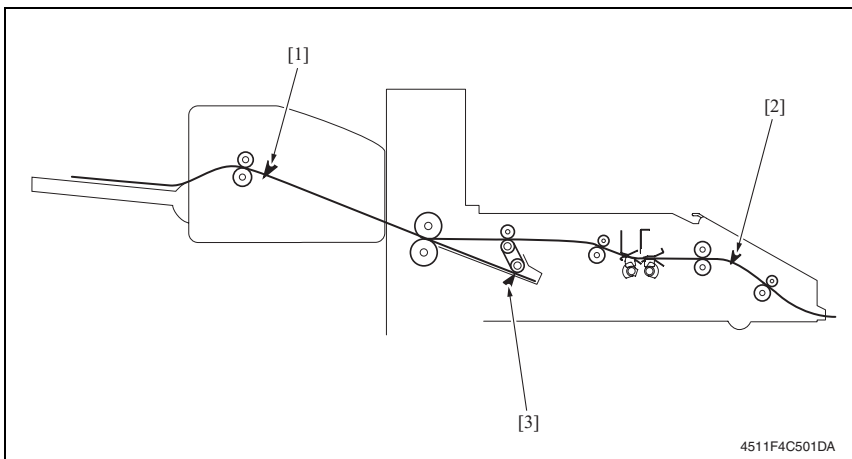

4511F4C501DA

- [1] Saddle exit sensor PS20
- [2] Entrance sensor PS1
- [3] Storage tray detect sensor PS3



### 8.3 Solution

#### 8.3.1 Initial check items

- When a paper misfeed occurs, first perform the following initial check items.

Check Item	Action
Does the paper meet product specifications?	Change the paper.
Is paper curled, wavy, or damp?	See "Solution when paper curl occurs" on P.38.
Is a foreign object present along the paper path, or is the paper path deformed or worn?	Clean or change the paper path.
Are the rolls/rollers dirty, deformed, or worn?	Clean or change the defective roll/roller.
Are the edge guide and trailing edge stop at the correct position to accommodate the paper?	Set as necessary.
Are the actuators found operational when checked for correct operation?	Correct or change the defective actuator.

#### 8.3.2 Solution when paper curl occurs

Step	Check items/actions	OK	—
1	Turn over the stacked paper in the paper tray.	OK	—
		NG	Go to step 2.
2	Does paper curl occur just after a warm-up has been completed or the sleep mode has been turned OFF?	YES	Go to step 3.
	Does paper curl occur under normal conditions (under conditions other than those mentioned above)?	YES	Go to step 5.
3	1. Call the Service Mode to the screen. 2. Select [System 1] → [Change Warm Up Time]. 3. Change the setting to [Mode3]. See P.393 of the main body service manual.	OK	—
		NG	Go to step 4.
4	1. Call the Service Mode to the screen. 2. Select [System 1] → [Change Warm Up Time]. 3. Change the setting to [Mode4]. See P.393 of the main body service manual.	—	—
5	1. Call the Service Mode to the screen. 2. Select [Machine] → [Fusing Temperature]. 3. Select a paper type. 4. Change the temperature of Heater Roller to [-10 °C]. See P.345 of the main body service manual.	OK	—
		NG	Go to step 6
6	1. Call the Service Mode to the screen. 2. Select [Machine] → [Fusing Temperature]. 3. Select a paper type. 4. Change the temperature of Heater Roller to [-20 °C]. See P.345 of the main body service manual.	—	—

### 8.3.3 Paper bundle exit misfeed

#### A. Detection timing

Type	Description
Paper bundle misfeed detection	The storage tray detecting sensor (PS3) is not turned OFF even after the set period of time has elapsed after the exit motor (M4) is energized.
	The saddle exit sensor (PS20) is not turned ON even after the set period of time has elapsed after the exit motor (M4) is energized.
	The saddle exit sensor (PS20) is not turned OFF even after the set period of time has elapsed after the saddle exit sensor (PS20) is turned ON.

#### B. Action

Relevant electrical parts	
Storage tray detect sensor (PS3) Saddle exit sensor (PS20) Exit motor (M4) Saddle exit motor (M8)	SD control board (SDCB)



Step	Action	WIRING DIAGRAM	
		Control signal	Location (Electrical component)
1	Initial check items	—	—
2	PS3 I/O check, sensor check	FSCB PJ14-8 (ON)	FS-519 C-12
3	PS20 I/O check, sensor check	SDCB PJ19-8 (ON)	SD-505 B-2
4	M4 operation check	FSCB PJ10-5 to 8	FS-519 C-3
5	M8 operation check	SDCB PJ4-1 to 2	SD-505 G-6
6	Change SDCB	—	—

**8.3.4 Staple unit 1 misfeed/Staple unit 2 misfeed**

**A. Detection timing**

Type	Description
Staple unit misfeed detection	The staple home position sensor in the staple unit is not turned ON even after the set period of time has elapsed after the staple motor rotates forward, and then the staple motor rotates backward, and the staple home position sensor in the staple unit is turned ON within the set period of time.

**B. Action**

Relevant electrical parts	
Staple unit 1 Staple unit 2	SD control board (SDCB)

Step	Action	WIRING DIAGRAM	
		Control signal	Location (Electrical component)
1	Initial check items	—	—
2	Drive coupling section check	—	—
3	Sensor check	—	—
4	Change staple unit 1	—	—
5	Change staple unit 2	—	—
6	Change SDCB	—	—

**8.3.5 Creasing section misfeed**

**A. Detection timing**

Type	Description
Creasing section misfeed detection	The entrance sensor (PS1) is not turned ON even after the set period of time has elapsed after the entrance motor (M1) is energized (beginning of backward rotation operation).
	The entrance sensor (PS1) is not turned OFF even after the set period of time has elapsed after the entrance motor (M1) is energized (beginning of forward rotation operation).

**B. Action**

Relevant electrical parts	
Entrance sensor (PS1) Entrance motor (M1)	SD control board (SDCB)



Step	Action	WIRING DIAGRAM	
		Control signal	Location (Electrical component)
1	Initial check items	—	—
2	PS1 I/O check, sensor check	FSCB PJ19-11 (ON)	FS-519 C-7
3	M1 operation check	FSCB PJ9-1 to 4	FS-519 C-6 to 7
4	Change SDCB	—	—



## 9. Malfunction code

### 9.1 Trouble code

- The machine's CPU performs a self-diagnostics function that, on detecting a malfunction, gives the corresponding malfunction code and maintenance call mark on the touch panel.

Code	Item	Description
C11A2	Saddle exit roller pressure/retraction failure	<ul style="list-style-type: none"> <li>The saddle exit roller home position sensor (PS18) is not turned ON even after the set period of time has elapsed after the saddle exit open/close motor (M9) is energized (beginning of pressure operation).</li> <li>The saddle exit roller home position sensor (PS18) is not turned OFF even after the set period of time has elapsed after the saddle exit open/close motor (M9) is energized (beginning of retraction operation).</li> </ul>
C11A4	Saddle exit motor failure	The lock signal is detected after the set period of time has elapsed after the saddle exit motor (M8) is energized.
C11A5	Saddle in & out guide motor failure	<ul style="list-style-type: none"> <li>The in &amp; out guide home sensor (PS23) is not turned OFF even after the set period of time has elapsed after the in &amp; out guide motor (M13) is energized (beginning of advancing operation).</li> <li>The in &amp; out guide home sensor (PS23) is not turned ON even after the set period of time has elapsed after the in &amp; out guide motor (M13) is energized (beginning of retracting operation).</li> </ul>
C11A6	Saddle layable guide drive failure	<ul style="list-style-type: none"> <li>The layable guide home sensor (PS24) is not turned ON even after the set period of time has elapsed after the layable guide motor (M14) is energized (beginning of return operation to predetermined position).</li> <li>The layable guide home sensor (PS24) is not turned OFF even after the set period of time has elapsed after the layable guide motor (M14) is energized (beginning of return operation to predetermined position).</li> </ul>
C11B5	Side staple 1 drive failure	Home position sensor 1 is not turned OFF even after the set period of time has elapsed after saddle staple motor 1 is energized (beginning of staple operation).
C11B6	Side staple 2 drive failure	Home position sensor 2 is not turned OFF even after the set period of time has elapsed after saddle staple motor 2 is energized (beginning of staple operation).
C11D0	Crease motor drive failure	<ul style="list-style-type: none"> <li>The crease roller home position sensor (PS22) is not turned OFF even after the set period of time has elapsed after the crease motor (M10) is energized (beginning of backward rotation operation).</li> <li>The crease roller home position sensor (PS22) is not turned ON even after the set period of time has elapsed after the crease motor (M10) is energized (beginning of forward rotation operation).</li> </ul>

## 9.2 Solution

### 9.2.1 C11A2: Saddle exit roller pressure/retraction failure

Relevant electrical parts	
Saddle exit open/close motor (M9)	SD control board (SDCB)
Saddle exit roller home position sensor (PS18)	



Step	Action	WIRING DIAGRAM	
		Control signal	Location (Electrical component)
1	Check the M9 connector for proper connection and correct as necessary.	—	—
2	Check M9 for proper drive coupling and correct as necessary.	—	—
3	M9 operation check	SDCB PJ4-6 to 7	SD-505 G-5 to 6
4	PS18 I/O check, sensor check	SDCB PJ9-6 (ON)	SD-505 B-2
5	Change SDCB	—	—

### 9.2.2 C11A4: Saddle exit motor failure

Relevant electrical parts	
Saddle exit motor (M8)	SD control board (SDCB)



Step	Action	WIRING DIAGRAM	
		Control signal	Location (Electrical component)
1	Check the M8 connector for proper connection and correct as necessary.	—	—
2	Check M8 for proper drive coupling and correct as necessary.	—	—
3	M8 operation check	SDCB PJ4-1 to 2	SD-505 G-6
4	Change SDCB	—	—

**9.2.3 C11A5: Saddle in & out guide motor failure**

Relevant electrical parts	
In & out guide motor (M13) In & out guide home sensor (PS23)	SD control board (SDCB)



Step	Action	WIRING DIAGRAM	
		Control signal	Location (Electrical component)
1	Check the M13 connector for proper connection and correct as necessary.	—	—
2	Check M13 for proper drive coupling and correct as necessary.	—	—
3	M13 operation check	SDCB PJ4-4 to 5	SD-505 G-6
4	PS23 I/O check, sensor check	SDCB PJ10-3 (ON)	SD-505 B-2 to 3
5	Change SDCB	—	—

**9.2.4 C11A6: Saddle layable guide drive failure**

Relevant electrical parts	
Layable guide motor (M14) Layable guide home sensor (PS24)	SD control board (SDCB)



Step	Action	WIRING DIAGRAM	
		Control signal	Location (Electrical component)
1	Check the M14 connector for proper connection and correct as necessary.	—	—
2	Check M14 for proper drive coupling and correct as necessary.	—	—
3	M14 operation check	SDCB PJ4-8 to 9	SD-505 G-5
4	PS24 I/O check, sensor check	SDCB PJ10-6 (ON)	SD-505 B-3
5	Change SDCB	—	—

**9.2.5 C11B5: Side staple 1 drive failure**

**9.2.6 C11B6: Side staple 2 drive failure**

Relevant electrical parts	
Staple unit 1 Staple unit 2	SD control board (SDCB)

Step	Action	WIRING DIAGRAM	
		Control signal	Location (Electrical component)
1	Check the staple units 1 and 2 connectors for proper connection and correct as necessary.	—	—
2	Check staple units 1 and 2 for proper drive coupling, and correct as necessary.	—	—
3	Staple units 1 and 2 operation check	—	—
4	Change staple units 1 and 2	—	—
5	Change SDCB	—	—

**9.2.7 C11D0: Crease motor drive failure**

Relevant electrical parts	
Crease motor (M10) Crease roller home position sensor (PS22)	SD control board (SDCB)



Step	Action	WIRING DIAGRAM	
		Control signal	Location (Electrical component)
1	Check the M10 connector for proper connection and correct as necessary.	—	—
2	Check M10 for proper drive coupling and correct as necessary.	—	—
3	M10 operation check	SDCB PJ3-1 to 2	SD-505 C-7
4	PS22 I/O check, sensor check	SDCB PJ2-3 (ON)	SD-505 C-7
5	Change SDCB	—	—



Blank Page



KONICA MINOLTA

**SERVICE MANUAL**

FIELD SERVICE

---

**JS-505**





# Revision history

After publication of this service manual, the parts and mechanism may be subject to change for improvement of their performance.

Therefore, the descriptions given in this service manual may not coincide with the actual machine.

When any change has been made to the descriptions in the service manual, a revised version will be issued with a revision mark added as required.

Revision mark:

- To indicate clearly a specific section revised within text,  is shown at the left margin of the corresponding revised section.  
The number inside  represents the number of times the revision has been made.
- To indicate clearly a specific page that contains a revision or revisions, the page number appearing at the left or right bottom of the specific page is marked with .  
The number inside  represents the number of times the revision has been made.

## NOTE

Revision marks shown in a page are restricted only to the latest ones with the old ones deleted.

- When a page revised in Ver. 2.0 has been changed in Ver. 3.0:  
The revision marks for Ver. 3.0 only are shown with those for Ver. 2.0 deleted.
- When a page revised in Ver. 2.0 has not been changed in Ver. 3.0:  
The revision marks for Ver. 2.0 are left as they are.

2008/01	2.0		Error correction
2007/07	1.0	—	Issue of the first edition
Date	Service manual Ver.	Revision mark	Descriptions of revision

# CONTENTS

## JS-505

### General

1. Product specification ..... 1

### Maintenance

2. Periodical check ..... 3

2.1 Maintenance procedure (Periodical check parts) ..... 3

2.1.1 Cleaning of the roller and roll ..... 3

3. Other ..... 4

3.1 Disassembly/adjustment prohibited items ..... 4

3.2 Disassembly/Assembly list (Other parts) ..... 5

3.2.1 Disassembly/Assembly parts list ..... 5

3.3 Disassembly/Assembly procedure ..... 5

3.3.1 Separator ..... 5

3.3.2 Front cover ..... 6

3.3.3 Rear left cover ..... 7

3.3.4 Rear right cover ..... 7

3.3.5 Upper tray ..... 8

3.3.6 Paper guide plate ..... 8

3.3.7 JS control board ..... 9

3.3.8 Transport motor ..... 9

3.3.9 Route change motor ..... 10

3.3.10 Shift motor ..... 11

3.3.11 Roller pressure/retraction clutch ..... 14

### Adjustment/Setting

4. How to use the adjustment section ..... 15

5. Sensor check ..... 16

5.1 Check procedure ..... 16

5.1.1 Sensor check screen ..... 16

5.1.2 Sensor check list ..... 16

6. Finisher operations ..... 17

6.1 Entering Finisher Check ..... 17

# Troubleshooting

7.	Jam display .....	19
7.1	Misfeed display .....	19
7.1.1	Misfeed display resetting procedure .....	19
7.2	Sensor layout.....	19
7.3	Solution .....	20
7.3.1	Initial check items .....	20
7.3.2	Solution when paper curl occurs.....	20
7.3.3	Job separator transport section misfeed.....	21
8.	Malfunction code.....	22
8.1	Trouble code.....	22
8.2	Solution .....	23
8.2.1	C1004: FNS communication error .....	23
8.2.2	C1182: Shift motor drive failure .....	23
8.2.3	C11A1: Exit roller pressure/retraction failure .....	24
8.2.4	C11E0: Finisher route change failure .....	24
8.2.5	CC155: Finisher ROM failure.....	25

# General

## 1. Product specification

### A. Type

Type	Built-in type 2-bin stacker
Installation	Installed in main body
Document alignment	Center

### B. Functions

Modes	Sort, group, sort offset, group offset
-------	--

### C. Paper

Exit tray	Size	Type	Capacity	
Lower tray	A6S, A5S/A5, B6S, B5S/B5, A4S/A4, B4, A3, A3 Wide, Post card S 5-1/2 X 8-1/2 S/5-1/2 X 8-1/2, 8-1/2 X 11S/8-1/2 X 11, 8-1/2 X 14, 11 X 17, 12-1/4 X 18 Max.: 311.1 mm X 1200 mm 12.25 inch X 47.25 inch Min.: 90 mm X 139.7 mm 3.5 inch X 5.5 inch	Plain paper (60 to 90 g/m <sup>2</sup> ) (16 to 24 lb)	150 sheets	
		Special paper	Thick paper 1 (91 to 150 g/m <sup>2</sup> ) (24.25 to 40 lb)	20 sheets
			Thick paper 2 (151 to 209 g/m <sup>2</sup> ) (40.25 to 55.5 lb)	
			Thick paper 3 (210 to 256 g/m <sup>2</sup> ) (55.75 to 68 lb)	
			Thick paper 4 (257 to 271 g/m <sup>2</sup> ) (68.25 to 72 lb)	
			OHP film	
			Post card	
			Label	
		Envelope	10 sheets	
Long size paper	1 sheet			
Upper tray	A5S, B5S/B5, A4S/A4, B4, A3 8-1/2 X 11S/8-1/2 X 11, 8-1/2 X 14, 11 X 17 Max.: 297 mm X 431.8 mm 11.75 inch X 17 inch Min.: 148 mm X 210 mm 5.75 inch X 8.25 inch	Plain paper (60 to 90 g/m <sup>2</sup> ) (16 to 24 lb)	50 sheets	

JS-505  
General

**D. Offset function**

Exit tray	Lower tray
Shift amount	30 mm
Types of paper to be used	Plain paper, Thick paper 1/2/3/4
Size	B5S/B5, A4S/A4, B4, A3 8-1/2 X 11S/8-1/2 X 11, 8-1/2 X 14, 11 X 17

**E. Machine specifications**

Power require-ments	DC 24 V ± 10 % (supplied from the main body)
	DC5 V ± 5 %
Max. power consumption	40 W or less
Dimensions	423 mm (W) X 477 mm (D) X 129.5 mm (H) 16.75 inch (W) X 18.75 inch (D) X 5 inch (H) 543 mm (W) X 477 mm (D) X 129.5 mm (H) *1 21.5 inch (W) X 18.75 inch (D) X 5 inch (H) *1
Weight	5.0 kg (11 lb)

\*1: Size when the paper exit tray is pulled out

**F. Operating environment**

- Conforms to the operating environment of the main body.

**NOTE**

- **These specifications are subject to change without notice.**

# Maintenance

## 2. Periodical check

### 2.1 Maintenance procedure (Periodical check parts)

#### NOTE

- The alcohol described in the cleaning procedure of maintenance represents the isopropyl alcohol.

#### 2.1.1 Cleaning of the roller and roll

##### A. Periodically cleaning parts/cycle

- Roller and roll: Every 300,000 prints

1. Remove the separator.

[See P.5](#)

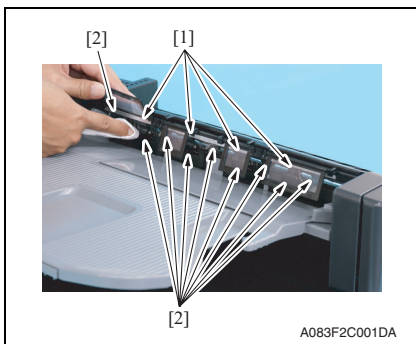

2. Using a cleaning pad dampened with alcohol, wipe the roller [1] and roll [2].

3. Remove the upper tray.

[See P.8](#)

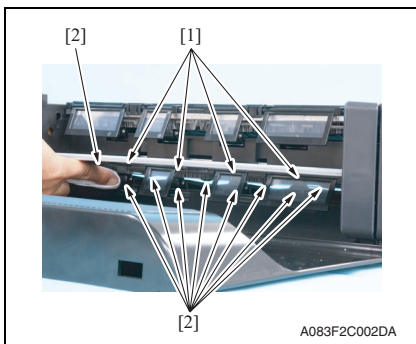

4. Using a cleaning pad dampened with alcohol, wipe the roller [1] and roll [2].



## 3. Other

### 3.1 Disassembly/adjustment prohibited items

#### A. Paint-locked screws

##### NOTE

- To prevent loose screws, a screw lock in blue or green series color is applied to the screws.
- The screw lock is applied to the screws that may get loose due to the vibrations and loads created by the use of machine or due to the vibrations created during transportation.
- If the screw lock coated screws are loosened or removed, be sure to apply a screw lock after the screws are tightened.

#### B. Red-painted screws

##### NOTE

- The screws which are difficult to be adjusted in the field are painted in red in order to prevent them from being removed by mistake.
- Do not remove or loosen any of the red-painted screws in the field. It should also be noted that, when two or more screws are used for a single part, only one representative screw may be marked with the red paint.

#### C. Variable resistors on board

##### NOTE

- Do not turn the variable resistors on boards for which no adjusting instructions are given in Adjustment/Setting.

#### D. Removal of PWBs

##### CAUTION

- When removing a circuit board or other electrical component, refer to “Handling of PWBs” and follow the corresponding removal procedures.
- The removal procedures given in the following omit the removal of connectors and screws securing the circuit board support or circuit board.
- Where it is absolutely necessary to touch the ICs and other electrical components on the board, be sure to ground your body.

### 3.2 Disassembly/Assembly list (Other parts)

#### 3.2.1 Disassembly/Assembly parts list

No.	Section	Part name	Ref. page
1	Unit	Separator	P.5
2	Exterior parts	Front cover	P.6
3		Rear left cover	P.7
4		Rear right cover	P.7
5		Upper tray	P.8
6		Paper guide plate	P.8
7		Board	JS control board
8	Motors	Transport motor	P.9
9		Route change motor	P.10
10		Shift motor	P.11
11	Clutch	Roller pressure/retraction clutch	P.14

### 3.3 Disassembly/Assembly procedure

#### 3.3.1 Separator

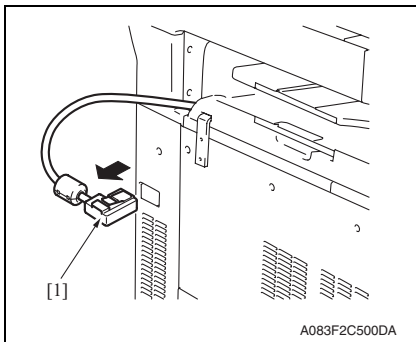

1. Remove the relay connector [1].

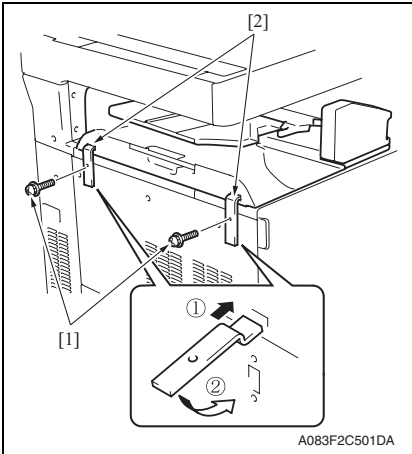

2. Remove two screws [1] and remove two fixtures [2].

**NOTE**

- When installing the attachment plates [2], the attachment plate A with pieces of metal is required to be attached to the left.
- Install the attachment plates as shown in the illustration. Press them downward and secure them with one screw each.

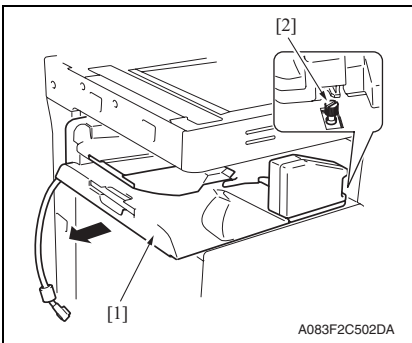

3. Remove the separator [1].

**NOTE**

- When installing the job separator, align the U-groove on the job separator with the shoulder screw [2].

**3.3.2 Front cover**

1. Remove the separator.  
See P.5

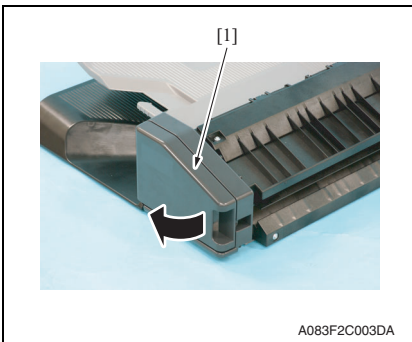

2. Open the misfeed clearing cover [1].

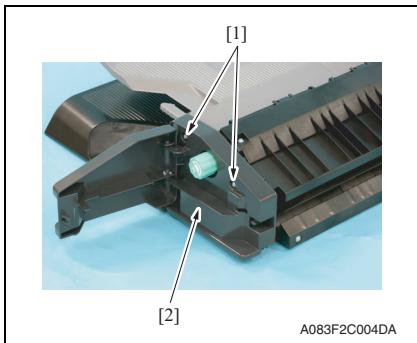

3. Remove two screws [1] and remove the front cover [2].

### 3.3.3 Rear left cover

1. Remove the separator.  
[See P.5](#)

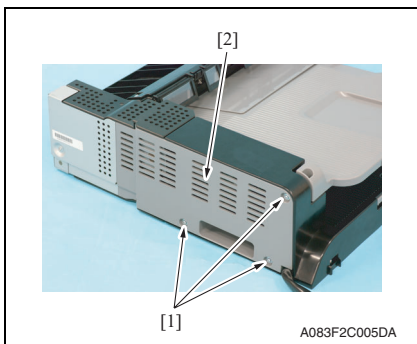

2. Remove three screws [1] and remove the rear left cover [2].

### 3.3.4 Rear right cover

1. Remove the separator.  
[See P.5](#)
2. Remove the rear left cover.  
[See P.7](#)

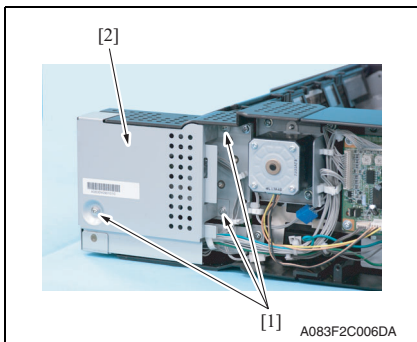

3. Remove three screws [1] and remove the rear right cover [2].

### 3.3.5 Upper tray

1. Remove the separator.  
See P.5

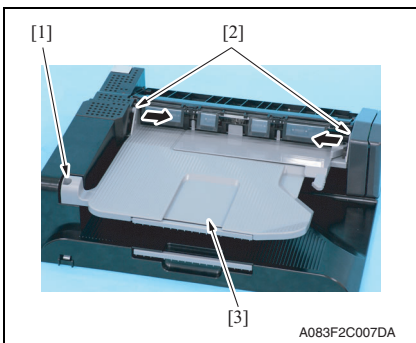

2. Remove the screw [1]. Push two protrusions [2] in the directions of the arrows and remove the upper tray [3].

### 3.3.6 Paper guide plate

1. Remove the separator.  
See P.5
2. Remove the upper tray.  
See P.8

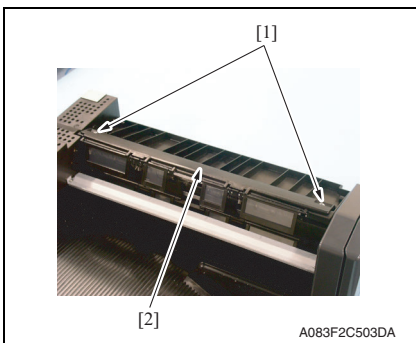

3. Remove two screws [1] and remove the paper guide plate cover [2].

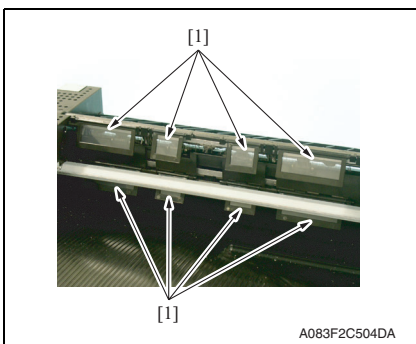

4. Remove eight paper guide plates [1].
- NOTE**
- When reinstalling the paper guide plates [1], make sure that the film side must face the roller.

### 3.3.7 JS control board

1. Remove the separator.  
[See P.5](#)
2. Remove the rear left cover.  
[See P.7](#)

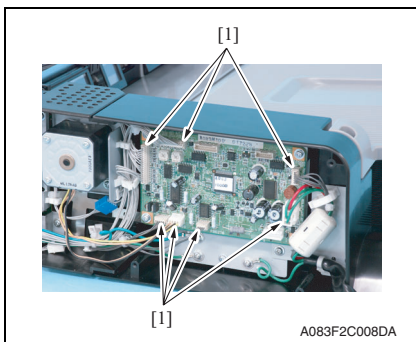

3. Remove all seven connectors [1] from the JS control board.

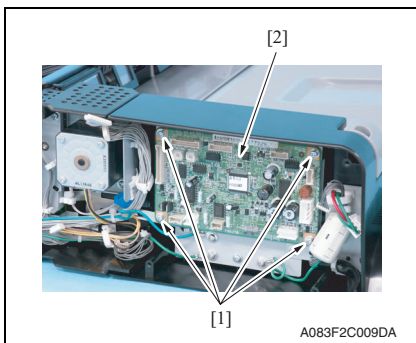

4. Remove four screws [1] and remove the JS control board [2].

### 3.3.8 Transport motor

1. Remove the separator.  
[See P.5](#)
2. Remove the rear left cover.  
[See P.7](#)

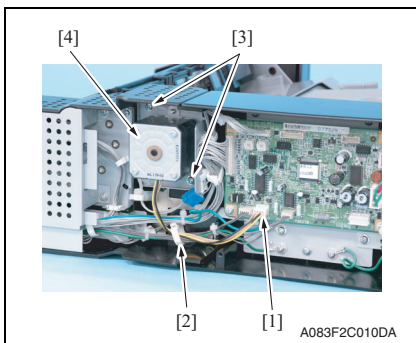

3. Disconnect the connector [1] and remove the wire saddle [2].
4. Remove two screws [3] and remove the transport motor assy [4].

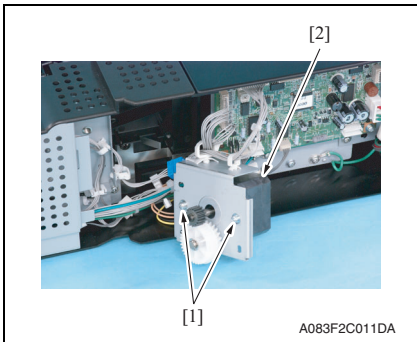

A083F2C011DA

- 5. Remove two screws [1] and remove the transport motor [2].

### 3.3.9 Route change motor

- 1. Remove the separator.  
[See P.5](#)
- 2. Remove the rear left cover.  
[See P.7](#)
- 3. Remove the rear right cover.  
[See P.7](#)

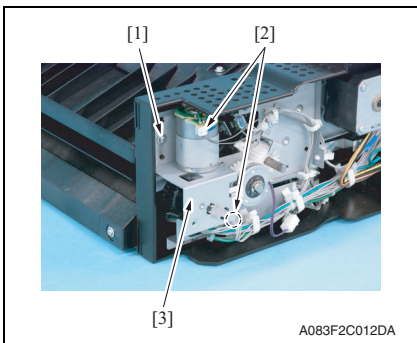

A083F2C012DA

- 4. Remove the screw [1] and disconnect two connectors [2], and remove the route change motor assy [3].

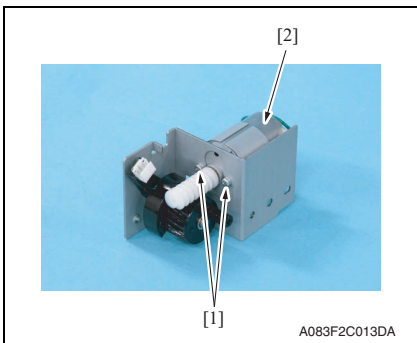

A083F2C013DA

- 5. Remove two screws [1] and remove the route change motor [2].

### 3.3.10 Shift motor

1. Remove the separator.  
See P.5
2. Remove the front cover.  
See P.6
3. Remove the route change motor.  
See P.10

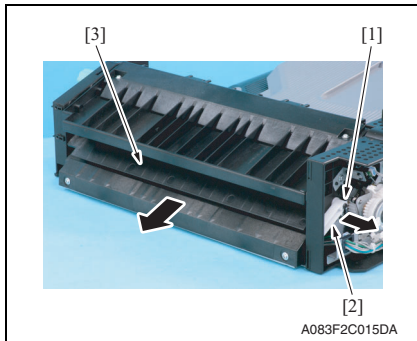

4. Remove the C-clip [1] and the lever [2], and remove the route change guide [3].

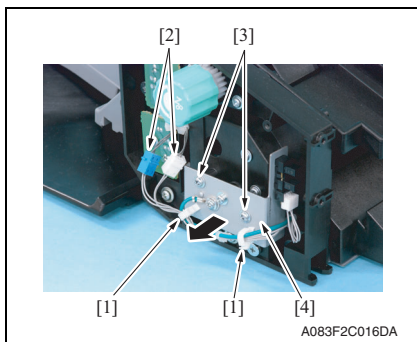

5. Remove two wire saddles [1], disconnect two connectors [2], and remove two screws [3]. Pull out the sensor assy [4] in the direction of the arrow.

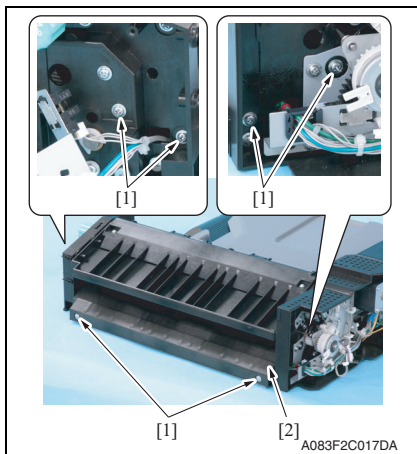

6. Remove six screws [1] and remove the transport guide/lower [2].



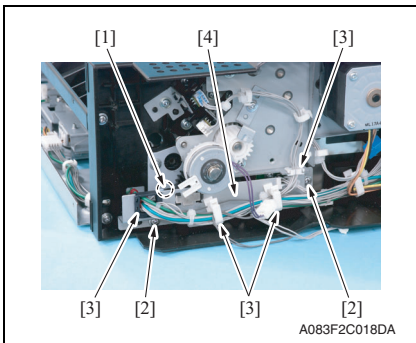

- 7. Disconnect the connector [1], remove two screws [2], and remove the harness from four wire saddles [3]. Remove the sensor mounting plate assy [4].

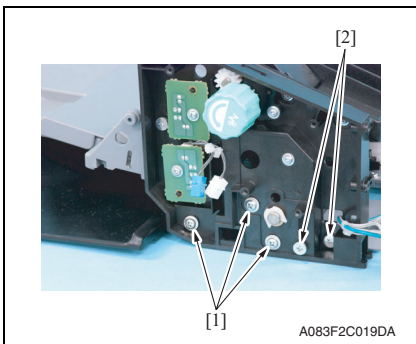

- 8. Remove three screws [1] and two shoulder screws [2].

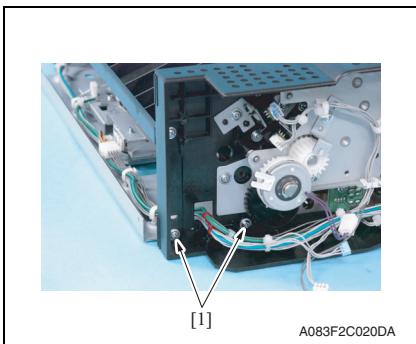

- 9. Remove two screws [1].

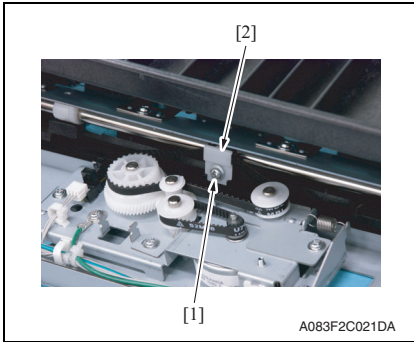

10. Remove the screw [1] and remove the belt fixed plate [2].

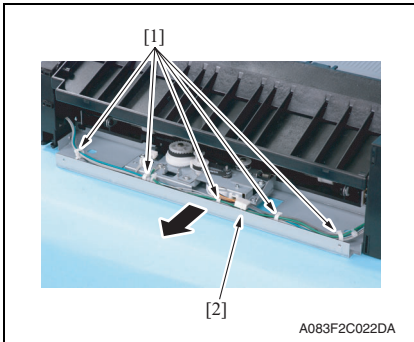

11. Remove five wire saddles [1] and pull out the shift drive section assy [2] in the direction of the arrow.

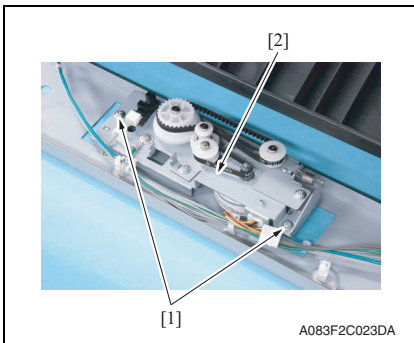

12. Remove two screws [1] and remove the shift motor assy [2].

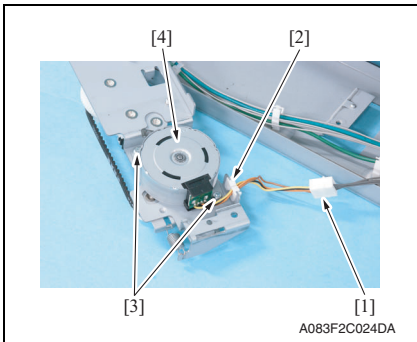

13. Disconnect the connector [1], remove wire saddle [2] and two screws [3], and remove the shift motor [4].

### 3.3.11 Roller pressure/retraction clutch

1. Remove the route change motor.  
[See P.10](#)

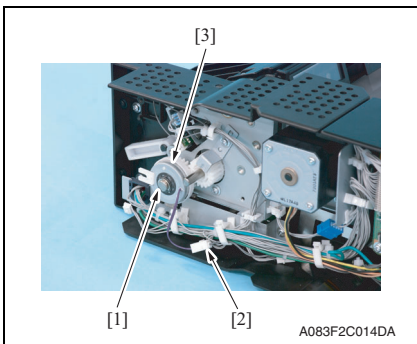

2. Remove the E-ring [1] and disconnect the connector [2], and remove the roller pressure/retraction clutch [3].

## Adjustment/Setting

### 4. How to use the adjustment section

- “Adjustment/Setting” contains detailed information on the adjustment items and procedures for this machine.
- Throughout this “Adjustment/Setting,” the default settings are indicated by “ ”.

#### **Advance checks**

Before attempting to solve the customer problem, the following advance checks must be made. Check to see if:

- The power supply voltage meets the specifications.
- The power supply is properly grounded.
- The machine shares the power supply with any other machine that draws large current intermittently (e.g., elevator and air conditioner that generate electric noise).
- The installation site is environmentally appropriate: high temperature, high humidity, direct sunlight, ventilation, etc.; levelness of the installation site.
- The original has a problem that may cause a defective image.
- The density is properly selected.
- The original glass, slit glass, or related part is dirty.
- Correct paper is being used for printing.
- The units, parts, and supplies used for printing (developer, PC drum, etc.) are properly replenished and replaced when they reach the end of their useful service life.
- Toner is not running out.

#### **⚠ CAUTION**

- **To unplug the power cord of the machine before starting the service job procedures.**
- **If it is unavoidably necessary to service the machine with its power turned ON, use utmost care not to be caught in the scanner cables or gears of the exposure unit.**
- **Special care should be used when handling the fusing unit which can be extremely hot.**
- **The developing unit has a strong magnetic field. Keep watches and measuring instruments away from it.**
- **Take care not to damage the PC drum with a tool or similar device.**
- **Do not touch IC pins with bare hands.**

## 5. Sensor check

### 5.1 Check procedure

#### A. Procedure

1. Call the Service Mode to the screen.  
[See P.338 of the main body service manual.](#)
2. Touch [State Confirmation].
3. Touch [Sensor Check].
4. Touch four times [↕].

#### 5.1.1 Sensor check screen

- This is only typical screen which may be different from what are shown on each individual main body.

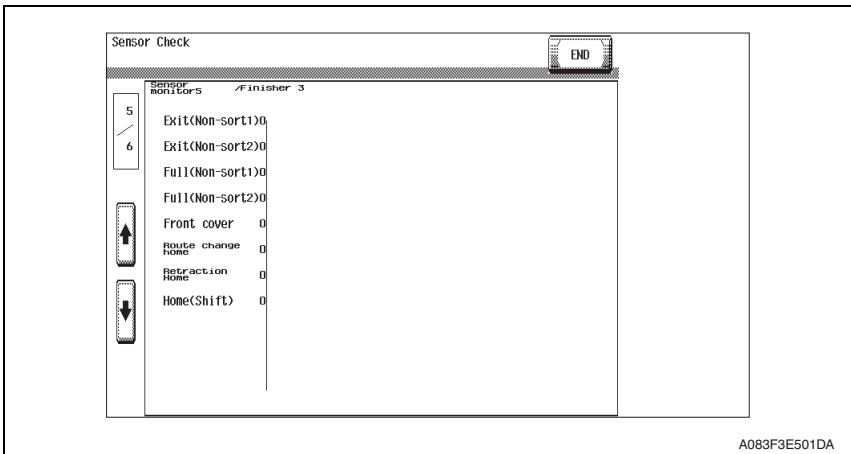

#### 5.1.2 Sensor check list

Symbol	Panel display	Part/Signal name	Operation characteristics/ panel display	
			1	0
PS1	Exit (Non-sort1)	Lower tray exit sensor	Paper present	Paper not present
PS2	Exit (Non-sort2)	Upper tray exit sensor	Paper present	Paper not present
T1FDTB/LED	Full (Non-sort1)	Lower tray paper full detect board/LED	Full	Other than full
T2FDTB/LED	Full (Non-sort2)	Upper tray paper full detect board/LED	Full	Other than full
PS3	Front cover	Front door sensor	Closed	Open
PS4	Route change home	Route change home sensor	Blocked	Unblocked
PS5	Retraction Home	Pressure/retraction home sensor	Blocked	Unblocked
PS6	Home (Shift)	Shift home sensor	Blocked	Unblocked

## 6. Finisher operations

### 6.1 Entering Finisher Check

1. Call the Service Mode to the screen.  
[See P.338 of the main body service manual.](#)
2. Touch [Finisher].
3. Touch [Job Separator].
4. Touch [Exit Motor Drive], [Route change Motor Drive], [Shift Motor Drive] or [Exit Roller Retraction].

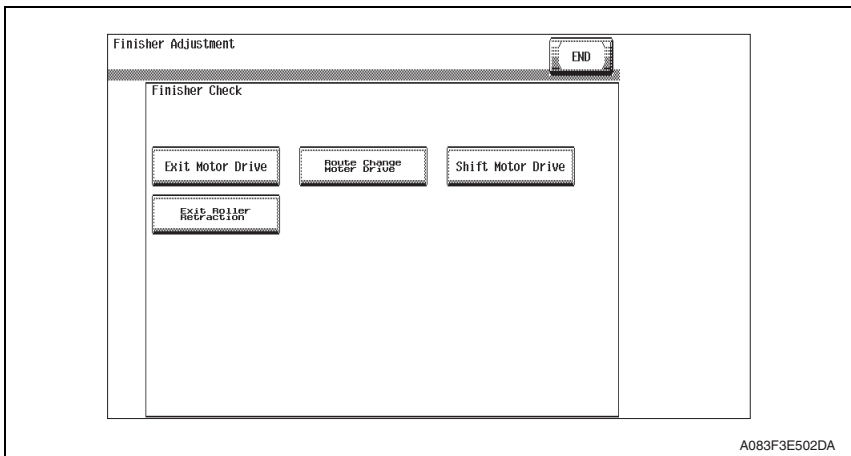

5. Touch the Start key to start the operation check.
6. Touch the Stop key to stop the ongoing operation check.

Blank Page

# Troubleshooting

## 7. Jam display

### 7.1 Misfeed display

- When misfeed occurs, message, misfeed location “Blinking” and paper location “Lighting” are displayed on the touch panel of the main body.

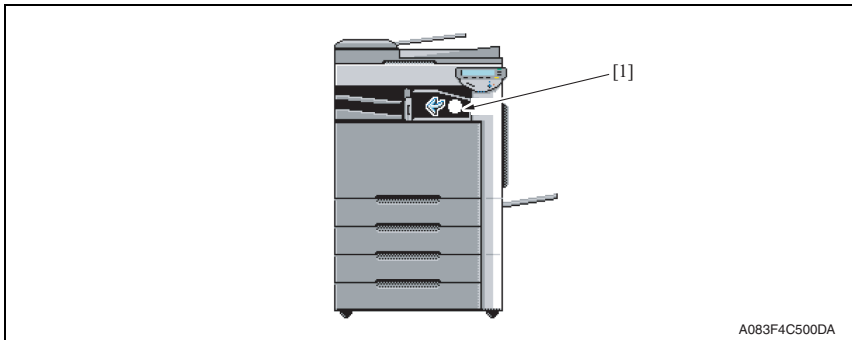

Display	Code	Misfeed location	Misfeed access location	Action
[1]	7216	Job separator transport section	Right door	<a href="#">P.21</a>

#### 7.1.1 Misfeed display resetting procedure

- Open the corresponding door, clear the sheet of paper misfed, and close the door.

### 7.2 Sensor layout

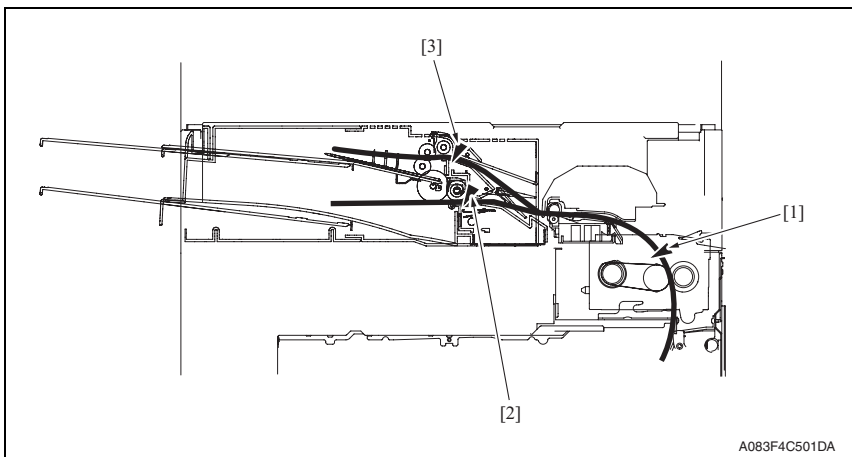

- [1] Paper exit sensor                      PS25
- [2] Lower tray exit sensor              PS1
- [3] Upper tray exit sensor                PS2



### 7.3 Solution

#### 7.3.1 Initial check items

- When a paper misfeed occurs, first perform the following initial check items.

Check Item	Action
Does the paper meet product specifications?	Change the paper.
Is paper curled, wavy, or damp?	See "Solution when paper curl occurs" on P.20.
Is a foreign object present along the paper path, or is the paper path deformed or worn?	Clean or change the paper path.
Are the rolls/rollers dirty, deformed, or worn?	Clean or change the defective roll/roller.
Are the actuators found operational when checked for correct operation?	Correct or change the defective actuator.

#### 7.3.2 Solution when paper curl occurs

Step	Check items/actions		
1	Turn over the stacked paper in the paper tray.	OK	—
		NG	Go to step 2.
2	Does paper curl occur just after a warm-up has been completed or the sleep mode has been turned OFF?	YES	Go to step 3.
	Does paper curl occur under normal conditions (under conditions other than those mentioned above)?	YES	Go to step 5.
3	1. Call the Service Mode to the screen. 2. Select [System 1] → [Change Warm Up Time]. 3. Change the setting to [Mode3]. See P.393 of the main body service manual.	OK	—
		NG	Go to step 4.
4	1. Call the Service Mode to the screen. 2. Select [System 1] → [Change Warm Up Time]. 3. Change the setting to [Mode4]. See P.393 of the main body service manual.	—	—
5	1. Call the Service Mode to the screen. 2. Select [Machine] → [Fusing Temperature]. 3. Select a paper type. 4. Change the temperature of Heater Roller to [-10 °C]. See P.345 of the main body service manual.	OK	—
		NG	Go to step 6
6	1. Call the Service Mode to the screen. 2. Select [Machine] → [Fusing Temperature]. 3. Select a paper type. 4. Change the temperature of Heater Roller to [-20 °C]. See P.345 of the main body service manual.	—	—

### 7.3.3 Job separator transport section misfeed

#### A. Detection timing

Type	Description
Transport section misfeed detection	The lower tray exit sensor (PS1) is not turned ON even after the set period of time has elapsed after the copier's paper exit sensor (PS25) is turned ON by the paper.
	The upper tray exit sensor (PS2) is not turned ON even after the set period of time has elapsed after the copier's paper exit sensor (PS25) is turned ON by the paper.
	The lower tray exit sensor (PS1) is not turned OFF even after the set period of time has elapsed after the copier's paper exit sensor (PS25) is turned OFF by the paper.
	The upper tray exit sensor (PS2) is not turned OFF even after the set period of time has elapsed after the copier's paper exit sensor (PS25) is turned OFF by the paper.
	The paper exit sensor (PS25) is not turned ON even after the set period of time has elapsed after the copier's paper exit sensor (PS25) is turned ON by the paper.
Detection of paper remaining in the transport section	The lower tray exit sensor (PS1) is turned ON when the power switch is set to ON, a door or cover is opened and closed, or a misfeed or malfunction is reset.
	The upper tray exit sensor (PS2) is turned ON when the power switch is set to ON, a door or cover is opened and closed, or a misfeed or malfunction is reset.

#### B. Action

Relevant electrical parts	
Paper exit sensor (PS25) Lower tray exit sensor (PS1) Upper tray exit sensor (PS2)	JS control board (JSCB) Printer control board (PRCB)



Step	Action	WIRING DIAGRAM	
		Control signal	Location (Electrical components)
1	Initial checks	—	—
2	PS25 I/O check, sensor check	—	—
3	PS1 I/O check, sensor check	JSCB PJ7-6 (ON)	JS-505 F-4 to 5
4	PS2 I/O check, sensor check	JSCB PJ7-9 (ON)	JS-505 F-4
5	JSCB replacement	—	—
6	PRCB replacement	—	—



## 8. Malfunction code

### 8.1 Trouble code

- The machine's CPU performs a self-diagnostics function that, on detecting a malfunction, gives the corresponding malfunction code and maintenance call mark on the touch panel.

Code	Description	Detection timing
C1004	FNS communication error	<ul style="list-style-type: none"> <li>When the JS control board (JSCB) is receiving data, a communication error is detected.</li> </ul>
C1182	Shift motor drive failure	<ul style="list-style-type: none"> <li>The shift home sensor (PS6) is not blocked after the set period of time has elapsed after the shift motor (M2) is turned ON (start of moving to the home position.)</li> <li>The shift home sensor (PS6) is not unblocked twice in a row after the set period of time has elapsed after the shift motor (M2) is turned ON (start of moving to the shift position.)</li> </ul>
C11A1	Exit roller pressure/retraction failure	<ul style="list-style-type: none"> <li>The pressure/retraction home sensor (PS5) is not blocked after the set period of time has elapsed after the roller pressure/retraction clutch (CL1) is turned ON (start of a pressure operation.)</li> <li>The pressure/retraction home sensor (PS5) is not unblocked after the set period of time has elapsed after the roller pressure/retraction clutch (CL1) is turned ON (start of a retraction operation.)</li> </ul>
C11E0	Finisher route change failure	<ul style="list-style-type: none"> <li>The route change home sensor (PS4) is not blocked after the set period of time has elapsed after the route change motor (M3) is turned ON (start of shifting to the lower tray route.)</li> <li>The route change home sensor (PS4) is not unblocked after the set period of time has elapsed after the route change motor (M3) is turned ON (start of shifting to the upper tray route.)</li> </ul>
CC155	Finisher ROM failure	<ul style="list-style-type: none"> <li>Data of flash ROM of the finishing options is determined to be faulty when the power is turned ON.</li> </ul>

## 8.2 Solution

### 8.2.1 C1004: FNS communication error

Relevant electrical parts			
JS control board (JSCB)			
Step	Action	WIRING DIAGRAM	
		Control signal	Location (Electrical component)
1	Disconnect and then connect the power cord. Turn OFF the main power switch, wait for 10 sec. or more, and turn ON the main power switch.	—	—
2	Rewrite firmware using the compact flash card.	—	—
3	Change JSCB	—	—

### 8.2.2 C1182: Shift motor drive failure

Relevant electrical parts			
Shift motor (M2) Shift home sensor (PS6)		JS control board (JSCB)	
Step	Action	WIRING DIAGRAM	
		Control signal	Location (Electrical component)
1	Check the M2 connector for proper connection and correct as necessary.	—	—
2	Check the connector of M2 for proper drive coupling and correct as necessary.	—	—
3	PS6 I/O check, sensor check	JSCB PJ7-18 (ON)	JS-505 F-3
4	M2 operation check	JSCB PJ4-1 to 4	JS-505 F-6
5	Change JSCB	—	—



**8.2.3 C11A1: Exit roller pressure/retraction failure**

Relevant electrical parts	
Roller pressure/retraction clutch (CL1) Pressure/retraction home sensor (PS5)	JS control board (JSCB)



Step	Action	WIRING DIAGRAM	
		Control signal	Location (Electrical component)
1	Check the CL1 connector for proper connection and correct as necessary.	—	—
2	Check the connector of CL1 for proper drive coupling and correct as necessary.	—	—
3	PS5 I/O check, sensor check	JSCB PJ7-12 (ON)	JS-505 F-4
4	CL1 operation check	JSCB PJ6-4 (ON)	JS-505 F-5
5	Change JSCB	—	—

**8.2.4 C11E0: Finisher route change failure**

Relevant electrical parts	
Route change motor (M3) Route change home sensor (PS4)	JS control board (JSCB)



Step	Action	WIRING DIAGRAM	
		Control signal	Location (Electrical component)
1	Check the M3 connector for proper connection and correct as necessary.	—	—
2	Check the connector of M3 for proper drive coupling and correct as necessary.	—	—
3	PS4 I/O check, sensor check	JSCB PJ7-15 (ON)	JS-505 F-4
4	M3 operation check	JSCB PJ6-1 to 2	JS-505 F-6
5	Change JSCB	—	—

**8.2.5 CC155: Finisher ROM failure**

Relevant electrical parts	
JS control board (JSCB)	

Step	Action	WIRING DIAGRAM	
		Control signal	Location (Electrical component)
1	Disconnect and then connect the power cord. Turn OFF the main power switch, wait for 10 sec. or more, and turn ON the main power switch.	—	—
2	Rewrite firmware using the compact flash card.	—	—
3	Change JSCB	—	—

JS-505

Troubleshooting

Blank Page



KONICA MINOLTA

**SERVICE MANUAL**

**FIELD SERVICE**

---

# FS-609/PK-501







# Revision history

After publication of this service manual, the parts and mechanism may be subject to change for improvement of their performance.

Therefore, the descriptions given in this service manual may not coincide with the actual machine.

When any change has been made to the descriptions in the service manual, a revised version will be issued with a revision mark added as required.

Revision mark:

- To indicate clearly a specific section revised within text,  is shown at the left margin of the corresponding revised section.  
The number inside  represents the number of times the revision has been made.
- To indicate clearly a specific page that contains a revision or revisions, the page number appearing at the left or right bottom of the specific page is marked with   
The number inside  represents the number of times the revision has been made.

## NOTE

Revision marks shown in a page are restricted only to the latest ones with the old ones deleted.

- When a page revised in Ver. 2.0 has been changed in Ver. 3.0:  
The revision marks for Ver. 3.0 only are shown with those for Ver. 2.0 deleted.
- When a page revised in Ver. 2.0 has not been changed in Ver. 3.0:  
The revision marks for Ver. 2.0 are left as they are.

2008/01	2.0		Error correction
2007/11	1.0	—	Issue of the first edition
Date	Service manual Ver.	Revision mark	Descriptions of revision

# CONTENTS

## FS-609/PK-501

### General

1. Product specification .....	1
1.1 FS-609 .....	1
1.2 PK-501 .....	4

### Maintenance

2. Other .....	5
2.1 Disassembly/adjustment prohibited items .....	5
2.2 Disassembly/Assembly list (Other parts) .....	6
2.3 Disassembly/Assembly procedure .....	7
2.3.1 Exit tray .....	7
2.3.2 Front cover .....	7
2.3.3 Rear cover .....	8
2.3.4 Upper door .....	8
2.3.5 Finisher tray upper cover .....	9
2.3.6 Upper cover .....	10
2.3.7 Horizontal transport unit .....	10
2.3.8 Side guide .....	11
2.3.9 Middle transport unit .....	12
2.3.10 Stapler .....	14
2.3.11 Saddle section .....	14
2.3.12 Finisher tray .....	16
2.3.13 Paddle section .....	17
2.3.14 Exit roller (upper) .....	18
2.3.15 Paddle .....	20
2.3.16 Exit roller (lower) and paper exit belt .....	21
2.3.17 Stapler/folding drive unit .....	24
2.3.18 Transport roller .....	26
2.3.19 Middle transport roller .....	28
2.3.20 Punch unit .....	29
2.3.21 Finisher control board (FSCB) .....	31
2.3.22 Punch control board (PKCB) .....	31
2.3.23 Transport motor unit .....	31
2.3.24 Entrance motor .....	32

FS-609/PK-501

General

Maintenance

Adjustment / Setting

Troubleshooting

2.3.25	Punch motor .....	32
2.3.26	Side registration motor.....	32

## Adjustment/Setting

3.	How to use the adjustment section .....	33
4.	Sensor check .....	34
4.1	Check procedure .....	34
4.1.1	Sensor check screen .....	34
4.1.2	Sensor check list.....	35
5.	Finisher .....	37
5.1	FN-X3 Adjustment .....	37
5.1.1	Center-Staple Position Adj.....	37
5.1.2	Half-Fold Position Adj.....	39
5.2	Punch option setting.....	40
6.	Mechanical adjustment .....	41
6.1	Adjustment of height and inclination.....	41
6.2	Adjustment of the Folding Position .....	43
6.2.1	Adjustment procedure.....	43
6.3	Stapler phase adjustment.....	47
6.3.1	Adjustment procedure.....	47
6.4	Saddle gear phase adjustment.....	51
6.4.1	Adjustment procedure.....	51
7.	Board switch .....	52
7.1	FSCB (Finisher control board).....	52
7.1.1	Adjustment of the folding positions .....	53
7.1.2	Adjustment of the center stapling position .....	54
7.1.3	Adjustment of the alignment plate position .....	55
7.2	PKCB (Punch control board) .....	57
7.2.1	Adjustment of the sensor output.....	57
7.2.2	Registration of the number of punch holes .....	58
7.2.3	Procedure after replacing the EEP-ROM (IC1002).....	59
7.2.4	Punch center position adjustment.....	59

## Troubleshooting

8.	Jam display .....	63
8.1	Misfeed display .....	63
8.1.1	Misfeed display resetting procedure .....	63
8.2	Sensor layout.....	64
8.3	Solution .....	65

8.3.1	Initial check items.....	65
8.3.2	Solution when paper curl occurs.....	65
8.3.3	Transport section misfeed.....	66
8.3.4	Horizontal transport section misfeed.....	66
8.3.5	Folding position section misfeed.....	67
8.3.6	Stapler section misfeed.....	67
8.3.7	Paper stack exit section misfeed.....	68
9.	Trouble code.....	69
9.1	Trouble code display.....	69
9.2	Trouble code list.....	69
9.3	Solution.....	72
9.3.1	C1180: Transport system drive malfunctions.....	72
9.3.2	C1181: Paddle motor malfunctions.....	72
9.3.3	C1183: Elevate mechanism malfunctions.....	73
9.3.4	C1192: Front aligning plate motor malfunctions.....	73
9.3.5	C1193: Rear aligning plate motor malfunctions.....	74
9.3.6	C11A4: Booklet exit motor malfunctions.....	74
9.3.7	C11B1: Stapler unit slide motor malfunctions.....	75
9.3.8	C11B4: Stapler/folding motor malfunctions.....	75
9.3.9	C11C1: Punch control board malfunctions.....	77
9.3.10	C11C2: Punch side registration motor malfunctions.....	78
9.3.11	C11C3: Punch motor malfunctions.....	78
9.3.12	C11C5: Punch sensor malfunctions.....	79
9.3.13	C1401: Backup RAM malfunction.....	80

FS-609/PK-501

General

Maintenance

Adjustment / Setting

Troubleshooting

FS-609/PK-501

General

Maintenance

Adjustment / Setting

Troubleshooting

Blank Page

# General

## 1. Product specification

### 1.1 FS-609

#### A. Type

Type	Multi staple finisher with saddle (Booklet)
Installation	Freestanding
Document alignment	Center
Supplies	Staple cartridge

#### B. Functions

Modes	Normal	Group, Sort, Group Offset, Sort Offset, Sort Staple, Center Staple & Fold
	Punch (Option)	Group Punch, Sort Punch, Group Offset Punch, Sort Offset Punch, Sort Staple Punch

#### C. Paper type

- Remove the finisher off the copier for feeding the long paper.
- The maximum loading capacity shown is for when loading the single type of paper (80g/m<sup>2</sup>)

#### (1) Group, Sort

Type	Size	Weight	Tray capacity *1			Exit tray	No. of sheets to be stapled
Plain paper	B5S/B5 to A3 wide 5-1/2 × 8-1/2S/ 5-1/2 × 8-1/2 to	60 to 90 g/m <sup>2</sup> 16 to 24 lb	No. of Sheet Height	A4S/ 8-1/2 × 11S or smaller 1,000 150 mm	B4/ 8-1/2 × 14 or larger 500 75 mm	Exit tray1	—
Envelop OHP film Label Thick paper	12-1/4 × 18	60 to 271 g/m <sup>2</sup> 16 to 72 lb		20 sheets			

\*1: Controlled by whichever reached earlier

#### (2) Sort offset, Sort group

Type	Size	Weight	Tray capacity			Exit tray	No. of sheets to be stapled
Plain paper	A5, B5S/B5 to A3 8-1/2 × 11S/ 8-1/2 × 11 to 11 × 17	60 to 90 g/m <sup>2</sup> 16 to 24 lb	No. of Sheets Height	A4S/ 8-1/2 × 11S or smaller 1,000 150 mm	B4/ 8-1/2 × 14 or larger 500 75 mm	Exit tray1	—
				Controlled by whichever reached earlier			

**(3) Sort staple**

Type	Size	Weight	Tray capacity			Exit tray	No. of sheets to be stapled	
Plain paper Thick paper	B5S/B5 to A3 8-1/2 x 11S/ 8-1/2 x 11 to 11 x 17	Normal Mode 60 to 90 g/m <sup>2</sup> 16 to 24 lb  Cover Mode 60 to 209 g/m <sup>2</sup> 16 to 55.5 lb	No. of Sheets	A4S/ 8-1/2 x 11S or smaller	B4/ 8-1/2 x 14 or larger	Exit tray1	Normal mode *1	
			Height No. of Sets	1,000 150 mm 30	500 75 mm 30		A4S/ 8-1/2 x 11S or smaller	B4/ 8-1/2 x 14 or larger
			Controlled by whichever reached earlier					

\*1: The number of sheets to be stapled is limited for high-density images.  
(Color Wise: 20 sheets x 20 sets)

**(4) Center staple & fold**

Type	Size	Weight	Tray capacity	Exit tray	No. of sheets to be stapled
Plain paper	A4S, B4, A3 8-1/2 x 11S/ 11 x 17	60 to 90 g/m <sup>2</sup> 16 to 24 lb	10 sets (No. of Sheets to be Stapled: 6 to 15 sheets) 20 sets (No. of Sheets to be Stapled: 2 to 5 sheets)	Exit tray2	Black copy 2 to 15 sheets (Max. 60 pages) Other copy 2 to 10 sheets (Max. 40 pages)

**D. Stapling**

Staple filling mode	Dedicated staple cartridge mode (5,000 staples)	
Staple detection	Available (Near empty: 40 remaining staples)	
Stapling position	Rear: Parallel 1 point	B5S/B5 to A3, 8-1/2 x 11S/8-1/2 x 11 to 11 x 17
	Front: Parallel 1 point	
	Side: Parallel 2 points	
	Center: Parallel 2 points	
Manual staple	None	
Folding mode	Roller pressure folding	
Folding position	Center of paper	

**E. No. of sheets to be stapled (sort staple)**

**(1) A4S, 8-1/2 × 11S or smaller**

No. of sheets to be stapled	No. of sets		
	Rear: Parallel	Center: Parallel	Front: Parallel
2	100	40	40
3 to 5	80	40	40
6 to 10	60	40	40
11 to 20	30	30	30
21 to 30	30	30	30
31 to 50	30 sets or 1,000 sheets		

**(2) B4, 8-1/2 × 14 or larger**

No. of sheets to be stapled	No. of sets		
	Rear: Parallel	Center: Parallel	Front: Parallel
2	100	50	50
3 to 5	80	40	40
6 to 10	40	40	40
11 to 20	30 sets or 1,000 sheets		
21 to 25			

**F. Machine specifications**

Power requirements	DC 24 V (supplied from the main body)
	DC 5 V (generated by finisher)
Max. power consumption	65 W or less
Dimensions	601 mm (W) × 603 mm (D) × 933 mm (H) 23.75 inch (W) × 23.75 inch (D) × 36.75 inch (H)
Weight	42.0 kg (92.5 lb)

**G. Operating environment**

Conforms to the operating environment of the main body.

**NOTE**

- These specifications are subject to change without notice.



## 1.2 PK-501

### A. Type

No. of holes (optional)	Metric: 4 holes, Inch: 2 holes / 3 holes
-------------------------	--

### B. Paper

Type	Size		Weight	Tray capacity	Exit tray	No. of sheets to be stapled
Plain paper Thick paper	4 holes	A4, A3	60 to 209 g/m <sup>2</sup> 16 to 55.5 lb	-	Elevator tray	-
	2 holes	8-1/2 x 11S/8-1/2 x 11, 8-1/2 x 14, 11 x 17				
	3 holes	8-1/2 x 11, 11 x 17				

### C. Machine specifications

Power requirements	Supplied from FS-609
Dimensions	90 mm (W) x 530 mm (D) x 170 mm (H) 3.75 inch (W) x 20.75 inch (D) x 6.75 inch (H)
Weight	2.6 kg (5.75 lb)

### D. Operating environment

Conforms to the operating environment of the main body.

#### NOTE

- These specifications are subject to change without notice.

# Maintenance

## 2. Other

### 2.1 Disassembly/adjustment prohibited items

#### A. Paint-locked screws

##### NOTE

- To prevent loose screws, a screw lock in blue or green series color is applied to the screws.
- The screw lock is applied to the screws that may get loose due to the vibrations and loads created by the use of machine or due to the vibrations created during transportation.
- If the screw lock coated screws are loosened or removed, be sure to apply a screw lock after the screws are tightened.

#### B. Red-painted screws

##### NOTE

- The screws which are difficult to be adjusted in the field are painted in red in order to prevent them from being removed by mistake.
- Do not remove or loosen any of the red-painted screws in the field. It should also be noted that, when two or more screws are used for a single part, only one representative screw may be marked with the red paint.

#### C. Variable resistors on board

##### NOTE

- Do not turn the variable resistors on boards for which no adjusting instructions are given in Adjustment/Setting.

#### D. Removal of PWBs

##### CAUTION

- When removing a circuit board or other electrical component, refer to “Handling of PWBs” and follow the corresponding removal procedures.
- The removal procedures given in the following omit the removal of connectors and screws securing the circuit board support or circuit board.
- Where it is absolutely necessary to touch the ICs and other electrical components on the board, be sure to ground your body.

## 2.2 Disassembly/Assembly list (Other parts)

No	Section	Part name	Ref. page
1	Exterior parts	Exit tray	<a href="#">P.7</a>
2		Front cover	<a href="#">P.7</a>
3		Rear cover	<a href="#">P.8</a>
4		Upper door	<a href="#">P.8</a>
5		Finisher tray upper cover	<a href="#">P.9</a>
6		Upper cover	<a href="#">P.10</a>
7	Unit	Horizontal transport unit	<a href="#">P.10</a>
8		Side guide	<a href="#">P.11</a>
9		Middle transport unit	<a href="#">P.12</a>
10		Stapler	<a href="#">P.14</a>
11		Saddle section	<a href="#">P.14</a>
12		Finisher tray	<a href="#">P.16</a>
13		Paddle section	<a href="#">P.17</a>
14		Exit roller (upper)	<a href="#">P.18</a>
15		Paddle	<a href="#">P.20</a>
16		Exit roller (lower) and paper exit belt	<a href="#">P.21</a>
17		stapler/folding drive unit	<a href="#">P.24</a>
18		Transport roller	<a href="#">P.26</a>
19		Middle transport roller	<a href="#">P.28</a>
20		Punch unit	<a href="#">P.29</a>
21	Electrical parts	Finisher control board	<a href="#">P.31</a>
22		Punch control board	<a href="#">P.31</a>
23		Transport motor unit	<a href="#">P.31</a>
24		Entrance motor	<a href="#">P.32</a>
25		Punch motor	<a href="#">P.32</a>
26		Side registration motor	<a href="#">P.32</a>

## 2.3 Disassembly/Assembly procedure

### 2.3.1 Exit tray

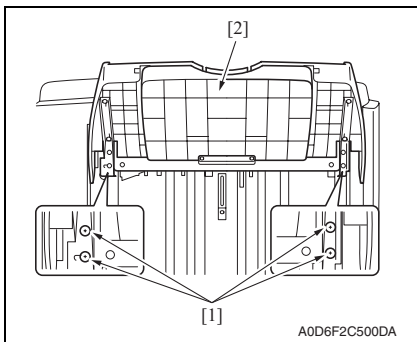

1. Remove four screws [1], and remove the exit tray [2].

### 2.3.2 Front cover

1. Remove the horizontal transport unit.  
[See P.10](#)
2. Remove the middle transport unit.  
[See P.12](#)

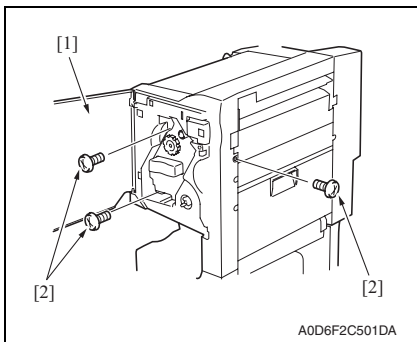

3. Open the front door [1].
4. Remove three screws [2].

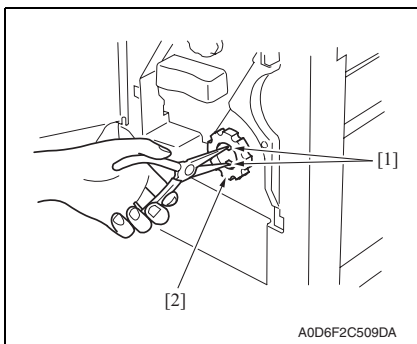

5. Using long nose pliers or a similar tool, pinch two tabs [1] and remove the misfeed-clearing dial [2].

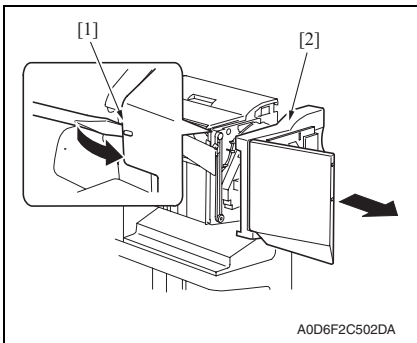

- Using a screwdriver or a similar tool, unhook the tab [1] and remove the front cover [2].

### 2.3.3 Rear cover

- Remove the horizontal transport unit. See P.10
- Remove the middle transport unit. See P.12

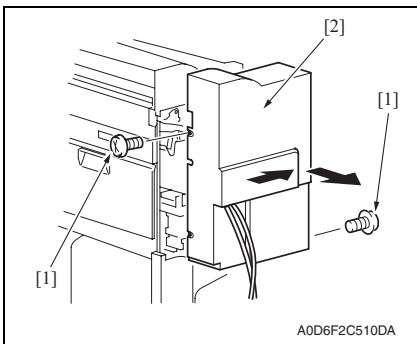

- Remove two screws [1], and remove the rear cover [2].

### 2.3.4 Upper door

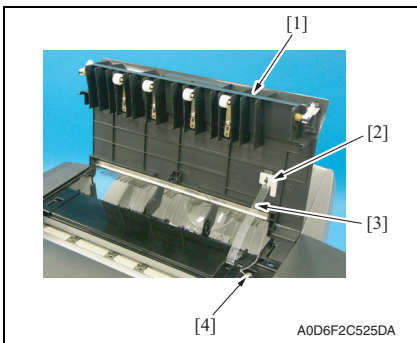

- Open the upper door [1], and remove the door band holder [2] by turning it clockwise.
- Remove the door band [3].
- Remove the screw [4], and remove the grounding wire.

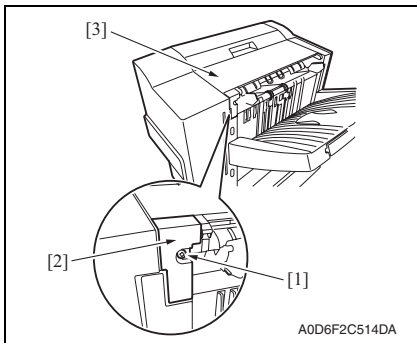

4. Remove the screw [1], remove the finisher tray rear cover [2].
5. Remove the upper door [3].

### 2.3.5 Finisher tray upper cover

1. Remove the front cover.  
[See P.7](#)
2. Remove the rear cover.  
[See P.8](#)
3. Remove the upper door.  
[See P.8](#)

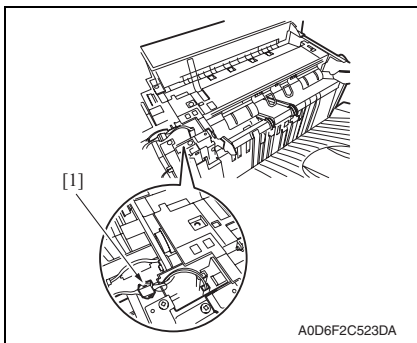

4. Disconnect the connector [1].

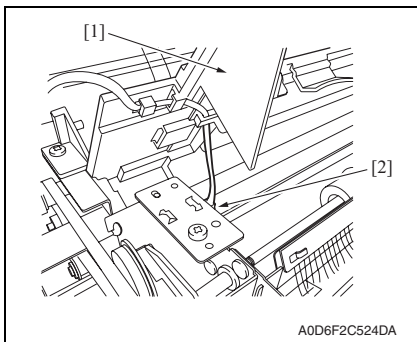

5. Disconnect the connector [2] while holding up the finisher tray upper cover [1], and remove the finisher tray upper cover [1].

### 2.3.6 Upper cover

1. Remove the front cover.  
See P.7
2. Remove the rear cover.  
See P.8

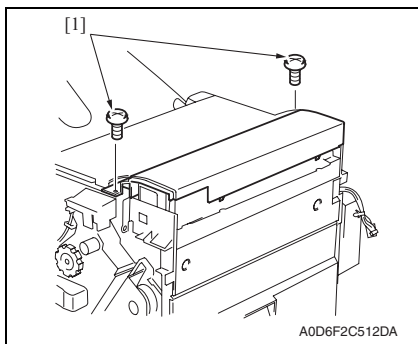

3. Remove two screws [1].

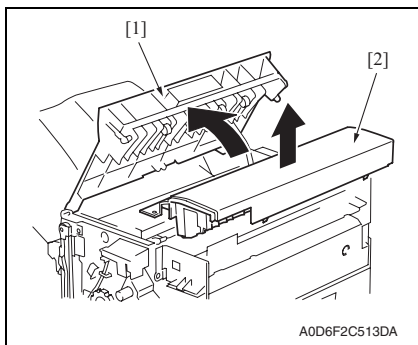

4. Open the upper door [1], and remove the upper cover [2].

### 2.3.7 Horizontal transport unit

1. Disconnect and move the finisher away from the main body.

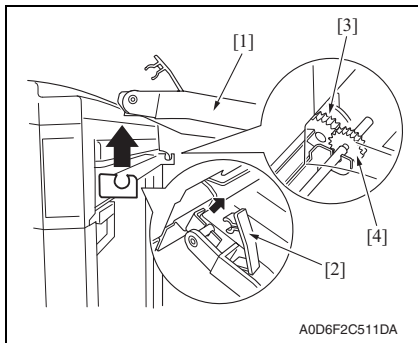

2. Raise the horizontal transport unit [1] straight upward and, keeping that condition, disengage the lock lever [2] and remove the horizontal transport unit [1].

#### NOTE

- At reinstallation, be sure to engage the lock lever [2] in position.
- At reinstallation, make sure that the gear [3] of the finisher is in positive mesh with the gear [4] of the horizontal transport unit.

**2.3.8 Side guide**

1. Remove the exit tray.  
See P.7
2. Remove the front cover.  
See P.7
3. Remove the rear cover.  
See P.8

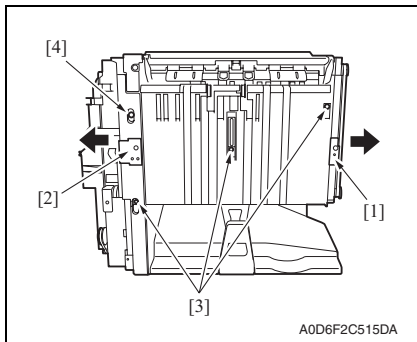

4. Derail the exit tray support plate (front) [1] and the exit tray support plate (rear) [2] to the outside off the respective rail grooves.
5. Remove three screws [3] and the shoulder screw [4].

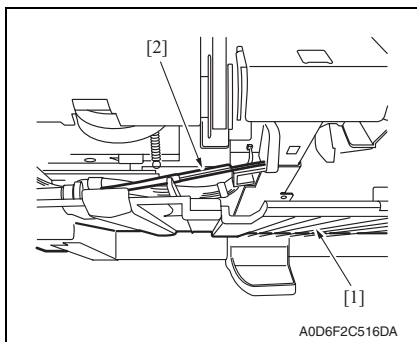

6. Pull down the side guide [1] lightly, disengage the exit tray home position detecting lever (rear) [2], and then remove the side guide [1].

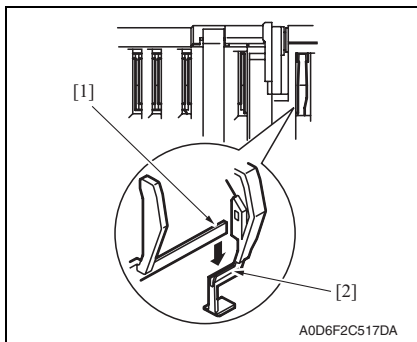

**NOTE**

- In reassembling, ensure of exact installation with the exit tray home position detecting lever (rear) [1] set in the slot of the exit tray home position detecting lever (center) [2].
- After reassembly, press each of these levers for several times to make sure of exact installation.



### 2.3.9 Middle transport unit

1. Remove the horizontal transport unit.  
See P.10

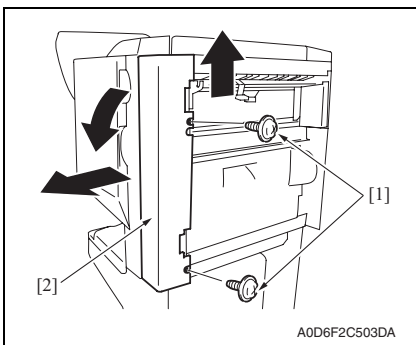

2. Remove two screws [1], and remove the middle front cover [2].

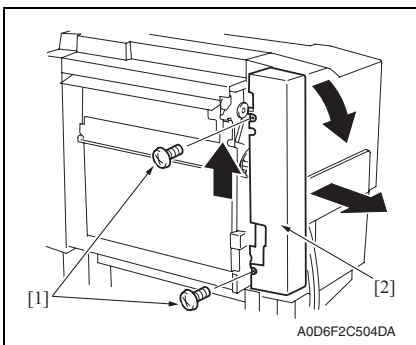

3. Remove two screws [1], and remove the middle rear cover [2].

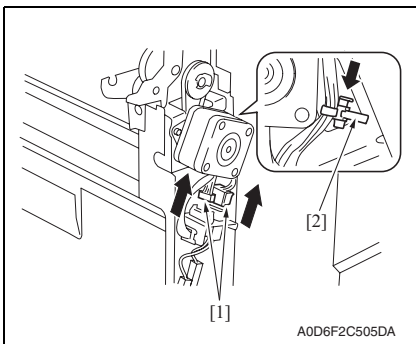

4. Disconnect two connectors [1].
5. Pinch the tie band [2], and remove it from the sheet metal.

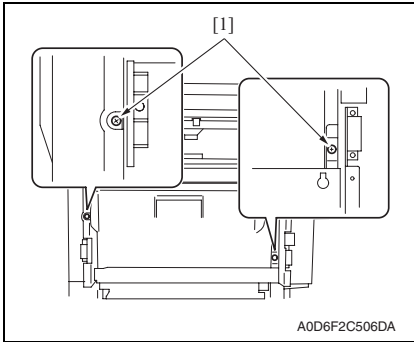

6. Remove two screws [1].

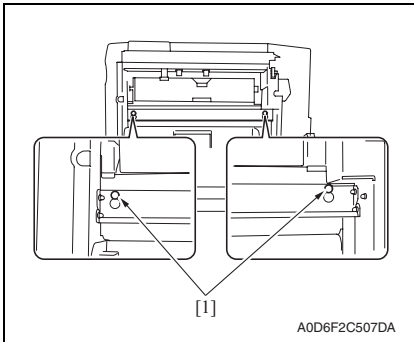

7. Loosen two screws [1].

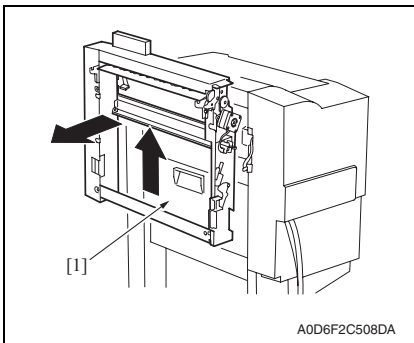

8. Remove the middle transport unit [1] by sliding it upwards.

### 2.3.10 Stapler

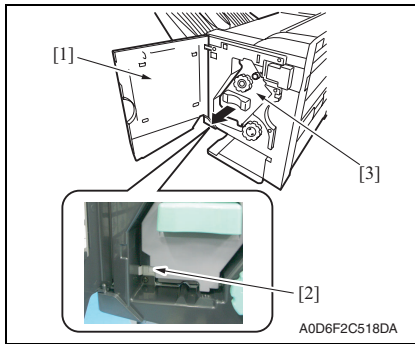

1. Open the front door [1].
2. Pull out the stapler [3] while pressing the stop lever [2].

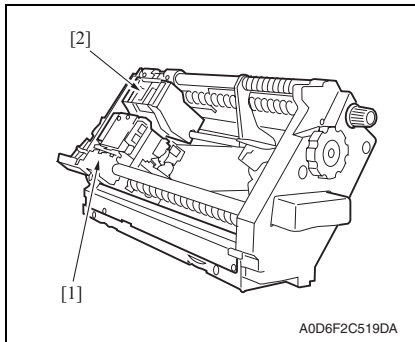

#### NOTE

- Do not remove the stapler from the shaft of the stapler frame, or displacement will be caused between the position to which the staple driver [1] (the lower unit of the stapler) feeds staples and the position from which the staple clincher [2] (the upper unit of the stapler) receives them.

### 2.3.11 Saddle section

1. Remove the front cover.  
[See P.7](#)
2. Remove the rear cover.  
[See P.8](#)
3. Remove the punch dust box.

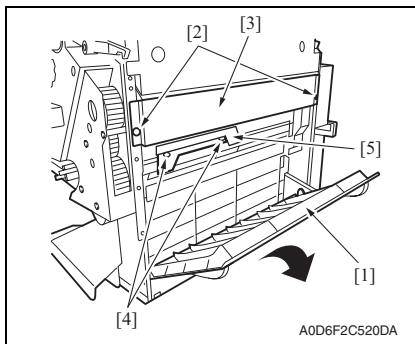

4. Open the jam access cover [1], remove two screws [2], and remove the right stay [3].
5. Remove two screws [4], and remove the lever [5].

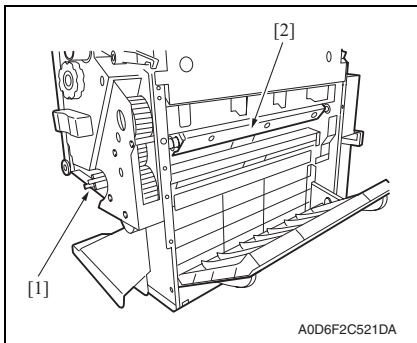

- 6. Turn the folding jam release dial [1] to move the paper pressure [2] inside.

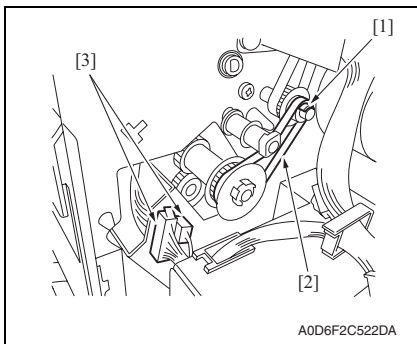

- 7. Remove the C-clip [1], and remove the belt [2].
- 8. Disconnect two connectors [3].

- 9. Remove the stapler.  
[See P.14](#)

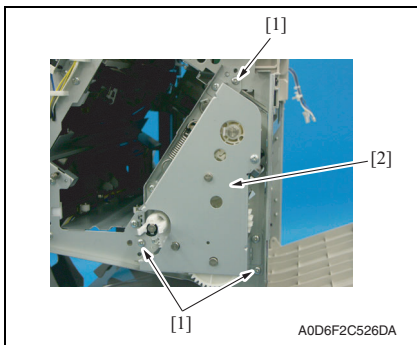

- 10. Remove three screws [1], and pull out and remove the saddle [2].

### 2.3.12 Finisher tray

1. Remove the finisher tray upper cover.  
See P.9
2. Remove the side guide.  
See P.11

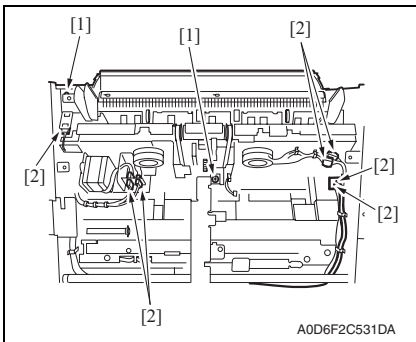

3. Remove two screws [1], and disconnect seven connectors [2].

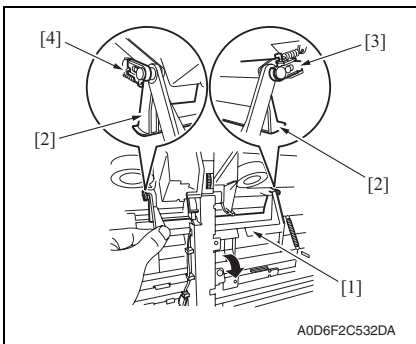

4. Pull out the finisher stopper base [1], and disengage the front claw [3] and the rear claw [4] of the finisher stopper [2].

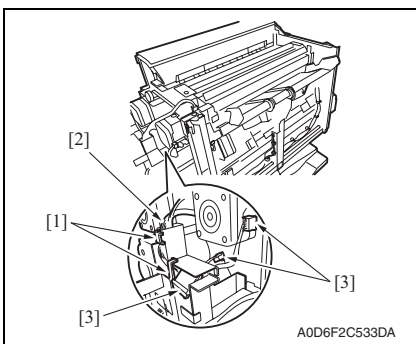

5. Remove the motor harness [2] from two harness saddles [1].
6. Disconnect three connectors [3].

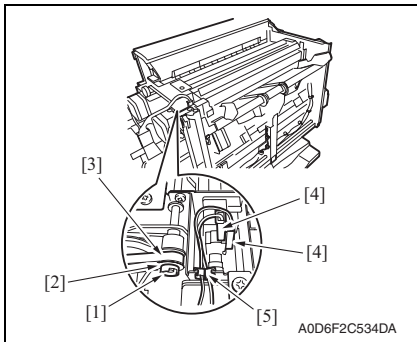

7. Remove the C-clip [1], and remove the spacer [2], and remove the belt [3] from the gear.
8. Disconnect two connectors [4], and remove the harness from the wire saddle [5].

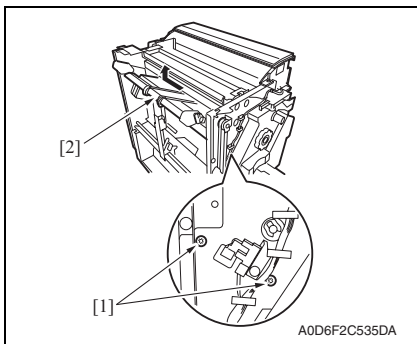

9. Remove two screws [1], and remove the finisher tray [2] by sliding it to the far side and lifting it.

### 2.3.13 Paddle section

1. Remove the finisher tray.  
[See P.16](#)

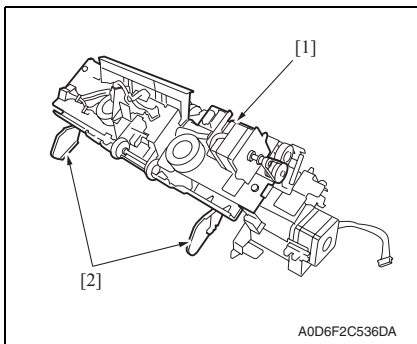

2. Place the finisher tray [1] as shown in the figure.

**NOTE**

- Be careful not to damage the aligning plate [2].

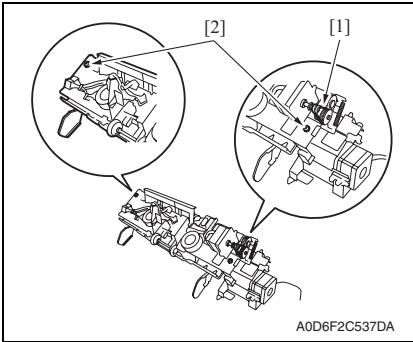

3. Remove the belt [1], and remove two screws [2].

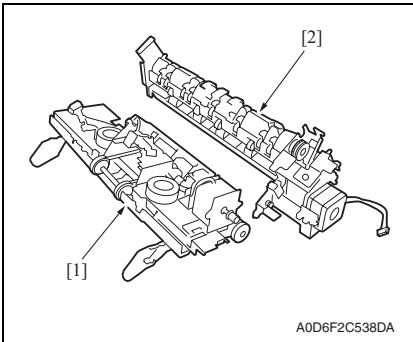

4. Separate the section into the tray section [1] and the paddle section [2].

### 2.3.14 Exit roller (upper)

1. Remove the paddle section.  
[See P.17](#)

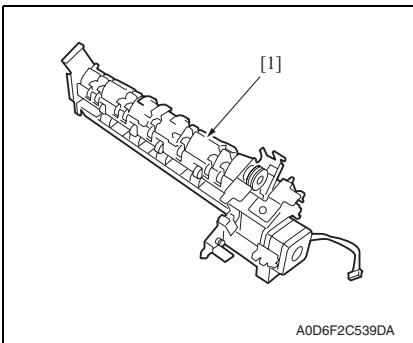

2. Place the paddle section [1] as shown in the figure.

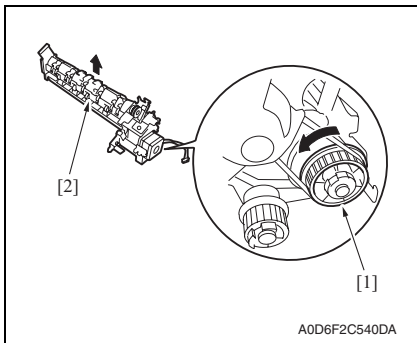

- 3. Turn the gear [1] in the direction indicated by an arrow to move up the exit roller (upper) section [2].

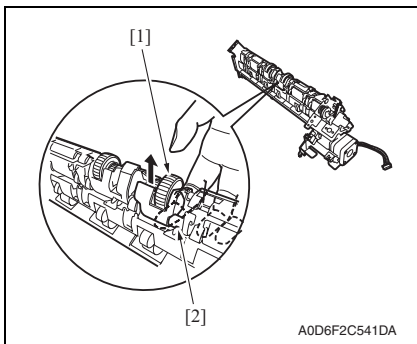

- 4. Push up the exit roller (upper) [1] from the bottom to release it from the shaft [2].

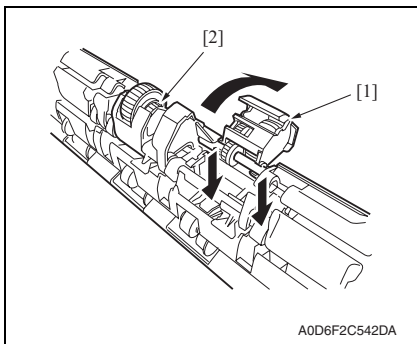

- 5. Turn up the exit roller (upper) [1], and then push it down to remove it.
- 6. Remove the front exit roller (upper) [2] as well in the same way.



### 2.3.15 Paddle

1. Remove the paddle section.  
See P.17

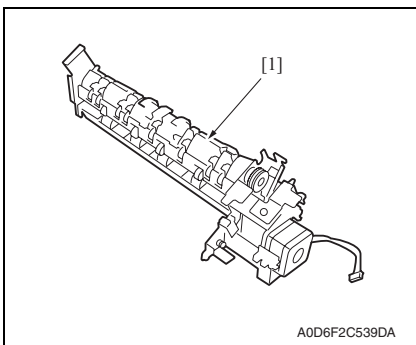

2. Place the paddle section [1] as shown in the figure.

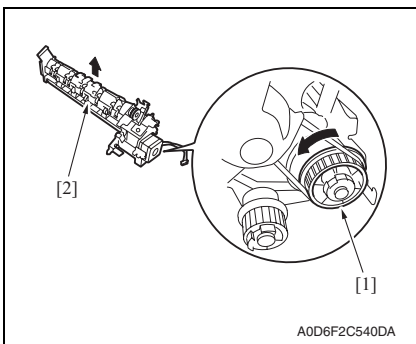

3. Turn the gear [1] in the direction indicated by an arrow to move up the exit roller (upper) section [2].

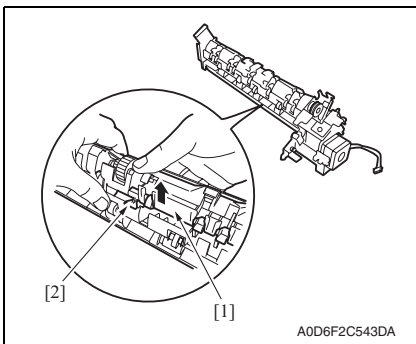

4. Push up the safety guide [1] from the bottom to release it on one side from the shaft [2].

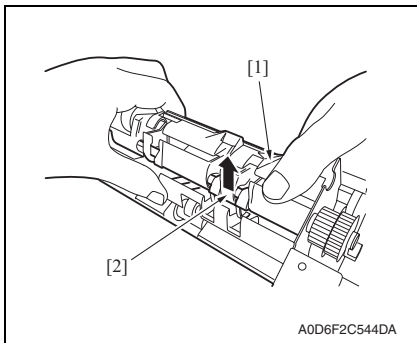

5. Push up the safety guide [1] from the bottom to release it from the shaft [2] and remove it.

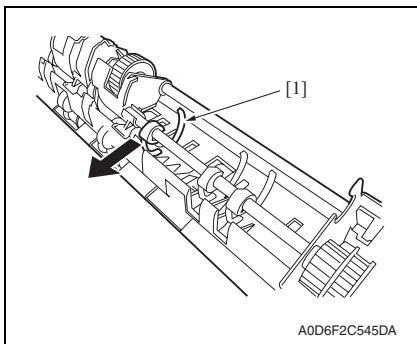

6. Remove the paddle [1].
7. Remove the other paddles as well in the same way.

### 2.3.16 Exit roller (lower) and paper exit belt

1. Remove the tray section.  
[See P.17](#)

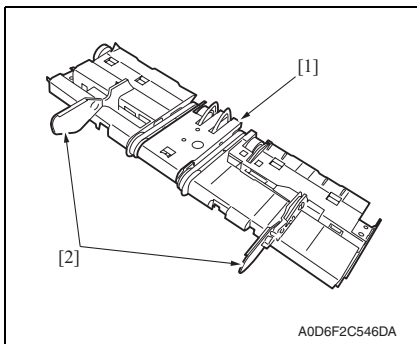

2. Slide the aligning plate (front) [2] and the aligning plate (rear) [2] outside to remove them from the tray [1].



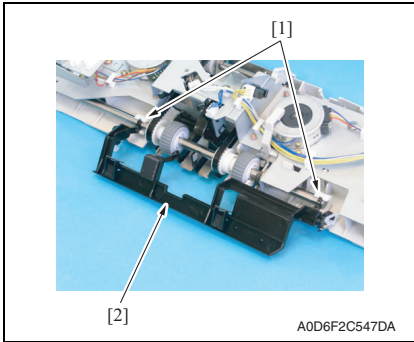

- 3. Remove two holders [1], and remove the finisher tray stopper [2].

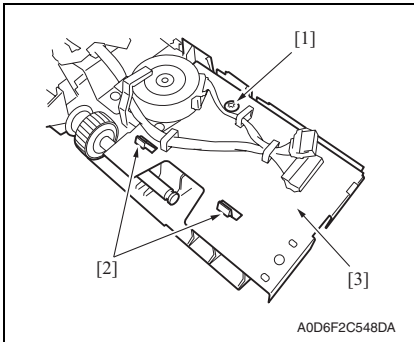

- 4. Remove the screw [1], and remove the paper guide (front) [3] while disengaging two claws [2].

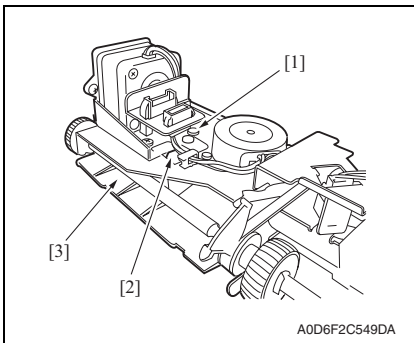

- 5. Remove the screw [1], and remove the paper guide (rear) [3] while disengaging the claw [2].

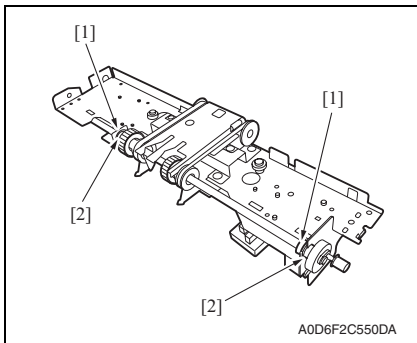

- 6. Remove two C-clips [1], and move two bushings [2] inside, respectively.

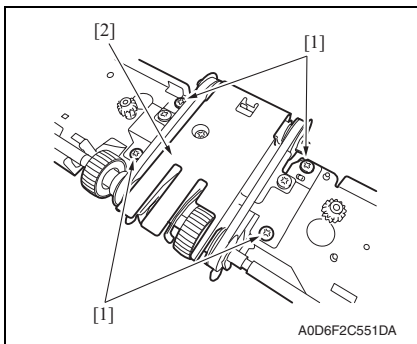

- 7. Remove four screws [1], and remove the exit roller (lower) section [2] by lifting it.

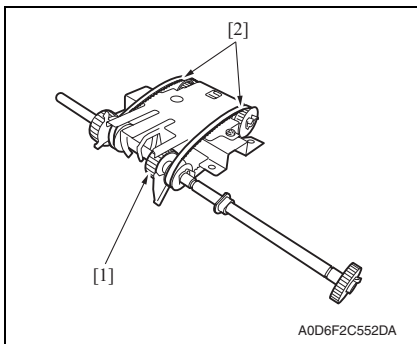

- 8. Remove the exit roller (lower) [1] and two paper exit belts [2].

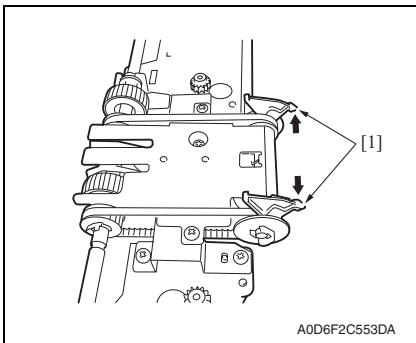

**NOTE**

- When installing, align the edge of claws of the paper exit belt [1].

**2.3.17 Stapler/folding drive unit**

1. Remove the rear cover.

See P.8

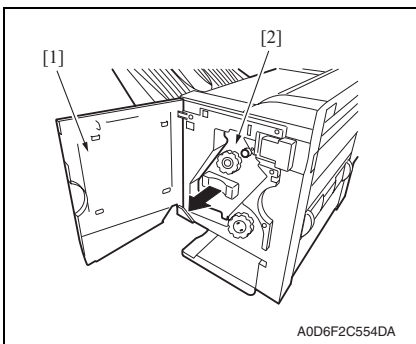

2. Open the front door [1], and slightly pull out the stapler section [2].

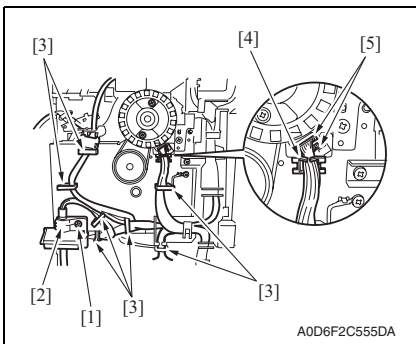

3. Remove screw [1], and remove the interface cable presser [2].
4. Remove the harness from seven wire saddles [3].
5. Remove the harness from the wire saddle [4], and disconnect two connectors [5].

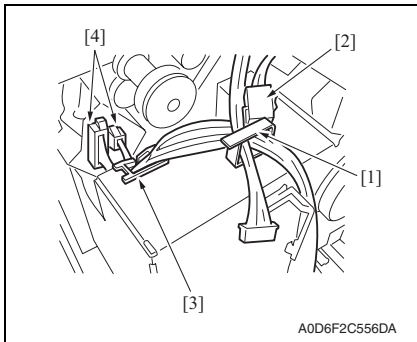

- 6. Remove the harness from the harness saddle [1], and disconnect the connector [2].
- 7. Remove the harness from the wire saddle [3], and disconnect two connectors [4].

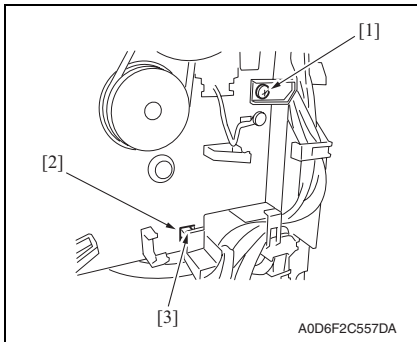

- 8. Remove the screw [1], and remove the claw [3] of harness guide from the square hole [2] in the base plate.

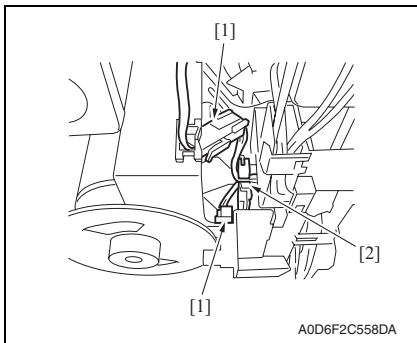

- 9. Disconnect two connectors [1], and remove the harness from the wire saddle [2].

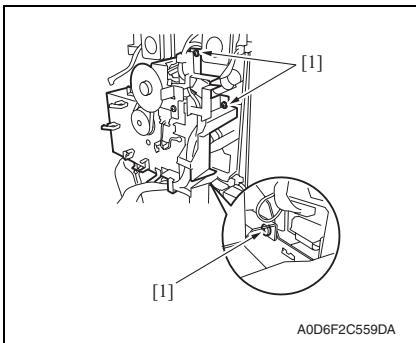

A0D6F2C559DA

10. Remove three screws [1].

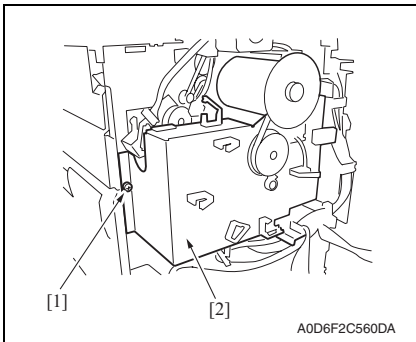

A0D6F2C560DA

11. Remove the screw [1], and remove the stapler/folding drive unit [2].

**2.3.18 Transport roller**

- 1. Remove the upper door.  
[See P.8](#)
- 2. Remove the upper cover.  
[See P.10](#)

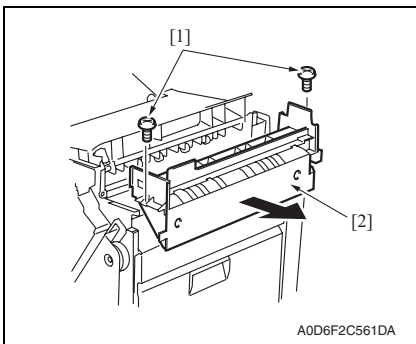

A0D6F2C561DA

3. Remove two screws [1], and remove the upper cover unit [2].

- 4. Remove the transport motor unit.  
[See P.31](#)

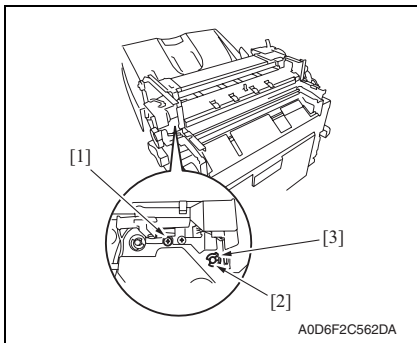

5. Remove the screw [1].
6. Remove the C-clip [2], and remove the bushing [3].

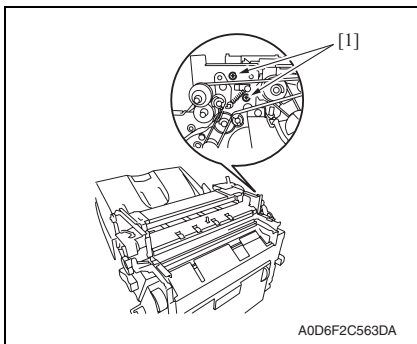

7. Remove two screws [1].

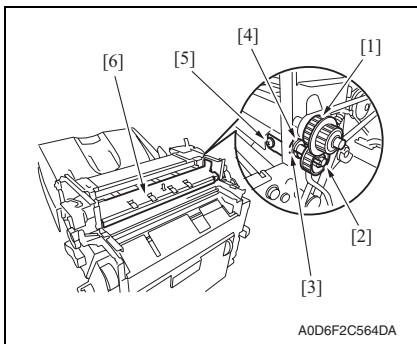

8. Remove the gear 1 [1], and remove the gear 2 [2] while disengaging the claw.

**NOTE**

- **Be careful not to lose the gear pin.**
9. Remove the C-clip [3], and remove the bushing [4].
  10. Remove the screw [5], and remove the paper guide (lower) [6].



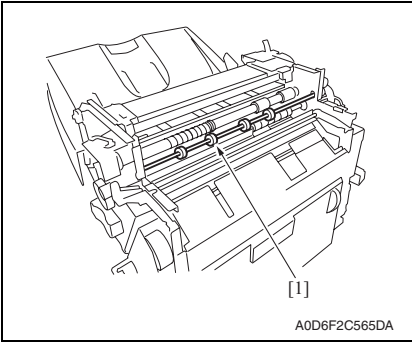

11. Remove the transport roller [1].

### 2.3.19 Middle transport roller

1. Remove the middle front cover and the middle rear cover.

See P.12

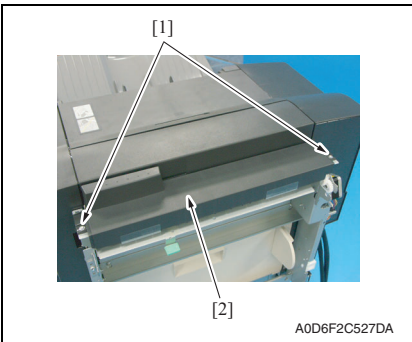

2. Remove two screws [1], and remove the middle upper cover [2].

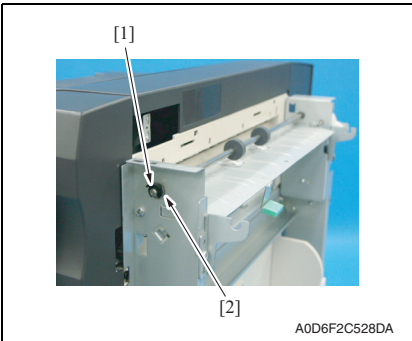

3. Remove the C-clip [1], and remove the bushing [2].

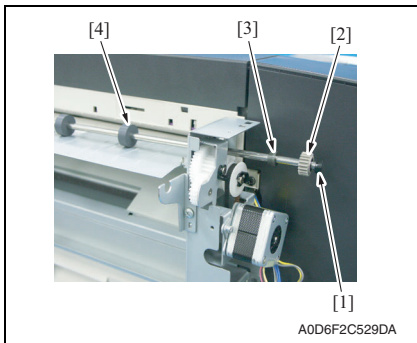

4. Shift the shaft assy in the orientation as shown on the left.
5. Remove the C-clip [1], the gear [2], the bushing [3], and remove the middle transport roller [4].

### 2.3.20 Punch unit

1. Remove the punch trash box.

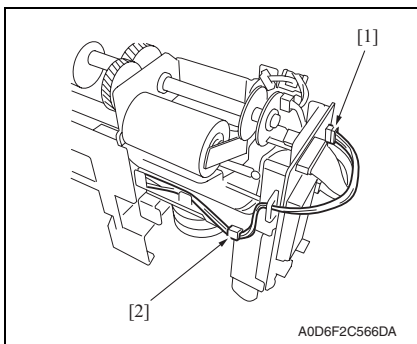

2. Disconnect the connector J1005 [1].
3. Remove the harness from the harness guide [2].

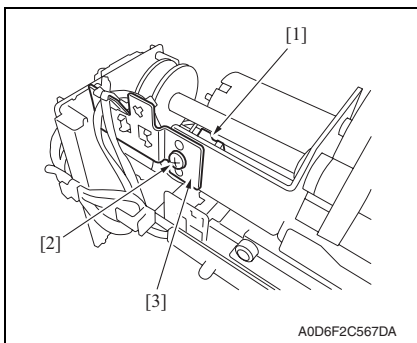

4. Disconnect the connector [1].
5. Remove the screw [2], and remove the sensor support plate [3].

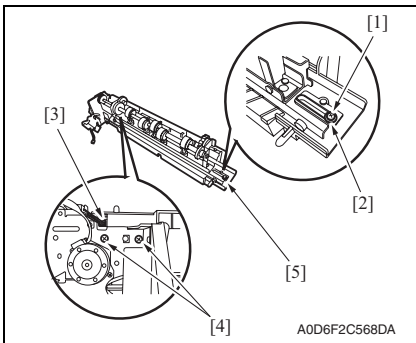

- 6. Remove the screw [1] and the washer [2].
- 7. Disconnect the connector [3].
- 8. Remove two screws [4], and remove the base cover [5].

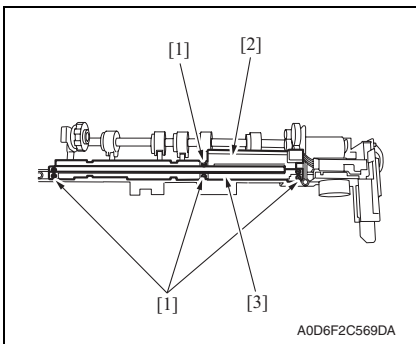

- 9. Remove four screws [1], and remove the Sensor unit (upper) [2] and the sensor unit (lower) [3].

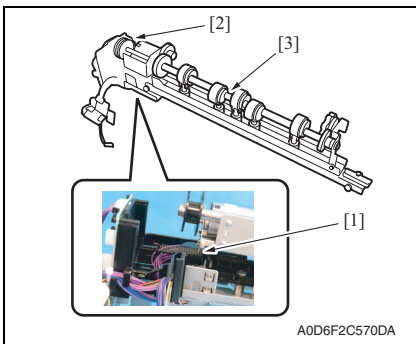

- 10. Remove the spring [1].
- 11. Remove the punch unit [2] from the side registration motor section [3].

### 2.3.21 Finisher control board (FSCB)

1. Remove the rear cover.  
See P.8

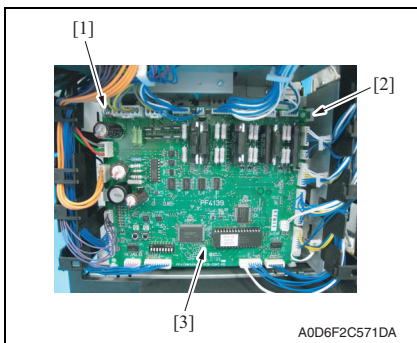

2. Disconnect all connectors on the board, and remove the screw [1].
3. Release the PCB support [2], and remove the finisher control board [3].

### 2.3.22 Punch control board (PKCB)

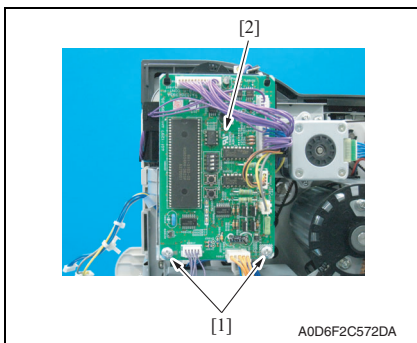

1. Remove two screws [1].
2. Disconnect all connectors, and remove the punch control board [2].

### 2.3.23 Transport motor unit

1. Remove the rear cover.  
See P.8

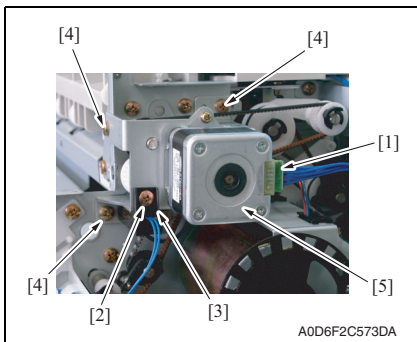

2. Disconnect the connector [1].
3. Remove screw [2], and remove the harness guide [3].
4. Remove three screws [4], and remove the transport motor unit [5].

### 2.3.24 Entrance motor

1. Remove the middle rear cover.  
See P.12

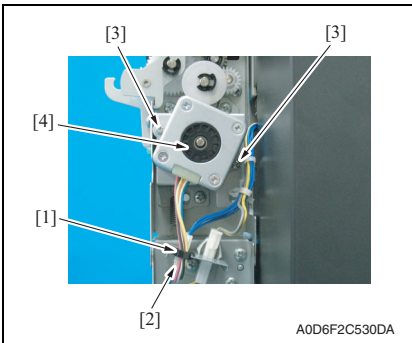

2. Remove the harness from the wire saddle [1].
3. Disconnect the connector [2].
4. Remove two screws [3], remove the entrance motor [4].

### 2.3.25 Punch motor

1. Remove the upper cover.  
See P.10

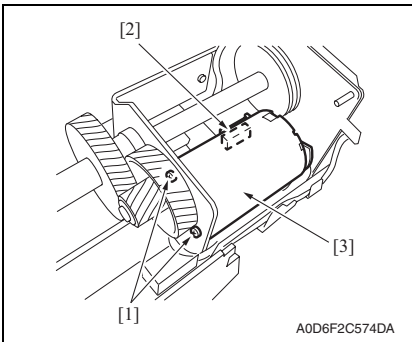

2. Remove two screws [1].
3. Disconnect the connector [2], and remove the punch motor [3].

### 2.3.26 Side registration motor

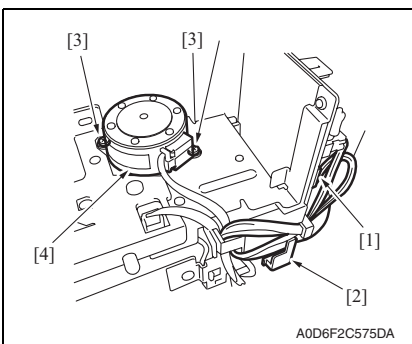

1. Disconnect the connector J1001 [1].
2. Remove the harness from the harness guide [2].
3. Remove two screws [3], and remove the side registration motor [4].

# Adjustment/Setting

## 3. How to use the adjustment section

- “Adjustment/Setting” contains detailed information on the adjustment items and procedures for this machine.
- Throughout this “Adjustment/Setting,” the default settings are indicated by “ ”.

### Advance Checks

Before attempting to solve the customer problem, the following advance checks must be made. Check to see if:

- The power supply voltage meets the specifications.
- The power supply is properly grounded.
- The machine shares the power supply with any other machine that draws large current intermittently (e.g., elevator and air conditioner that generate electric noise).
- The installation site is environmentally appropriate: high temperature, high humidity, direct sunlight, ventilation, etc.; levelness of the installation site.
- The original has a problem that may cause a defective image.
- The density is properly selected.
- The Original Glass, slit glass, or related part is dirty.
- Correct paper is being used for printing.
- The units, parts, and supplies used for printing (developer, PC Drum, etc.) are properly replenished and replaced when they reach the end of their useful service life.
- Toner is not running out.

### Caution

- **Be sure to unplug the power cord of the machine before starting the service job procedures.**
- **If it is unavoidably necessary to service the machine with its power turned ON, use utmost care not to be caught in the Scanner Cables or gears of the Exposure Unit.**
- **Special care should be used when handling the Fusing Unit which can be extremely hot.**
- **The Developing Unit has a strong magnetic field. Keep watches and measuring instruments away from it.**
- **Take care not to damage the PC Drum with a tool or similar device.**
- **Do not touch IC pins with bare hands.**

# 4. Sensor check

## 4.1 Check procedure

1. Call the Service Mode to the screen.  
[See P.338 of the main body service manual.](#)
2. Touch the [State Confirmation] key.
3. Touch the [Sensor Check] key.
4. Touch five times [▼].

### 4.1.1 Sensor check screen

- This is only typical screen which may be different from what are shown on each individual main body.

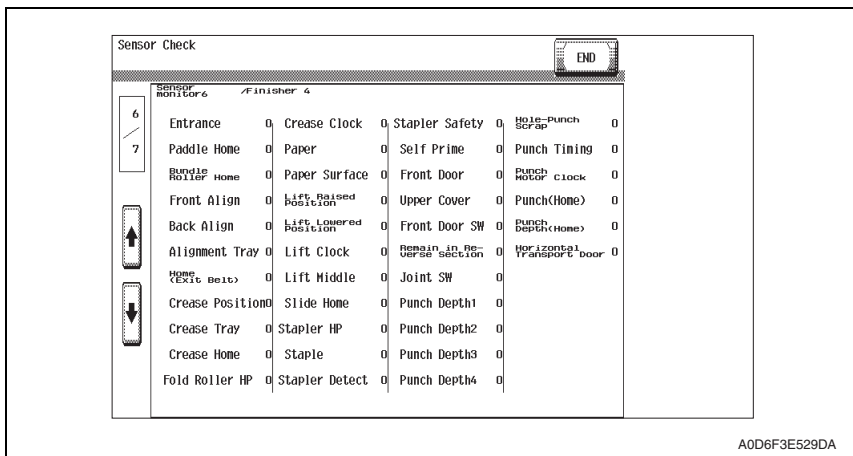

## 4.1.2 Sensor check list

Symbol	Panel display	Part/Signal name	Operation characteristics/ Panel display	
			1	0
PS1	Entrance	Entrance sensor	Paper present	Paper not present
PS2	Paddle Home	Paddle home position sensor	At home	Not at home
PS3	Bundle Roller Home	Bundle exit roller home position sensor	At home	Not at home
PS4	Front Align	Front aligning plate home position sensor	At home	Not at home
PS5	Back Align	Rear aligning plate home position sensor	At home	Not at home
PS6	Alignment Tray	Finisher tray sensor	Paper present	Paper not present
PS7	Home (Exit Belt)	Exit belt home position sensor	At home	Not at home
PS10	Crease Position	Folding position sensor	Paper present	Paper not present
PS13	Crease Tray	Saddle tray sensor	Paper present	Paper not present
PS11	Crease Home	Folding home position sensor	At home	Not at home
PS12	Fold Roller HP	Folding roller home position sensor	At home	Not at home
PS14	Crease Clock	Staple/folding motor clock sensor	Blocked	Unblocked
PS8	Paper	Exit tray sensor	Paper present	Paper not present
PS9	Paper Surface	Exit tray home position sensor	Detected	
PS15	Lift Raised Position	Lift upper limit sensor	Upper limit	
PS16	Lift Lowered Position	Lift lower limit sensor	Lower limit	
PS17	Lift Clock	Lift motor clock sensor	Blocked	Unblocked
—	Lift Middle	—	Full	
PS18	Slide Home	Slide home position sensor	Not at home	At home
PS19	Stapler HP	Stapler drive home position sensor	At home	Not at home
PS20	Staple	Staple detecting sensor	Supplied	Empty
—	Stapler Detect	—		Detected
SW3	Stapler Safety	Stapler safely switch (Rear)	Open	Close
SW4		Stapler safely switch (Front)		
PS21	Self Prime	Self-priming sensor		Ready
PS22	Front Door	Front door open sensor	Close	Open
PS23	Upper Cover	Upper cover open sensor	Close	Open
SW1	Front Door SW	Front door open switch	Close	Open
PS27	Remain in Reverse Section	Turnover empty sensor		Horizontal
SW2	Joint SW	Joint open switch	Close	Open
—	Punch Depth 1	—	—	—
—	Punch Depth 2	—	—	—

Sensor monitor 6 / Finisher 4



Symbol	Panel display	Part/Signal name	Operation characteristics/ Panel display	
			1	0
—	Punch Depth 3	—	—	—
—	Punch Depth 4	—	—	—
—	Hole-Punch Scrap	—	Full	
—	Punch Timing	—	—	—
PS3	Punch Motor Clock	Punch motor cock sensor	Blocked	Unblocked
PS1	Punch (Home)	Punch home position sensor	At home	Not at home
PS2	Punch Depth (Home)	Side registration home sensor	At home	Not at home
PS26	Horizontal Transport Door	Horizontal unit door sensor	Blocked	Unblocked

## 5. Finisher

### 5.1 FN-X3 Adjustment

#### 5.1.1 Center-Staple Position Adj.

- The stapling position is adjusted by aligning the stapling position to the folding position.
- This adjustment is made in the service mode of the main body. Since the adjustment is made in increments of 1 mm, this adjustment is useful for eliminating a displacement of 1mm or more.
- For the effective adjustment of a minimal displacement smaller than 1 mm, refer to “6. Board switch.”

See P.52

**Adjustable range: - 7 to + 7 mm (Increment: 1 mm)**

#### A. Adjustment procedure

1. Set A3 or 11 x 17 to the feed tray.
2. Touch these keys in this order: [Center staple & Fold] → [OK].
3. Set five sheets of A3 or 11 x 17 original (blank paper acceptable) in the original tray.
- These five sheets are used for adjustment to minimize variation.
4. press the start key.
5. Renew the center folding of the finished copies.  
Take the top surface of the finished copies as A, and the under surface as B.
6. Check the deviation of the stapling position from the newly folded position.

#### NOTE

- In checking the deviation, refer not to the folded position by the Finisher but to the newly folded position.

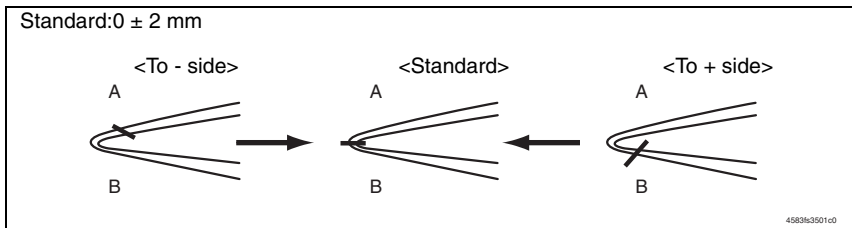

7. Set the mode to the Service Mode.  
See P.338 of the main body service manual.
8. Touch [Finisher].
9. Touch [FN-X3Adjustment].

10. Touch [Center-Staple Position Adj.]

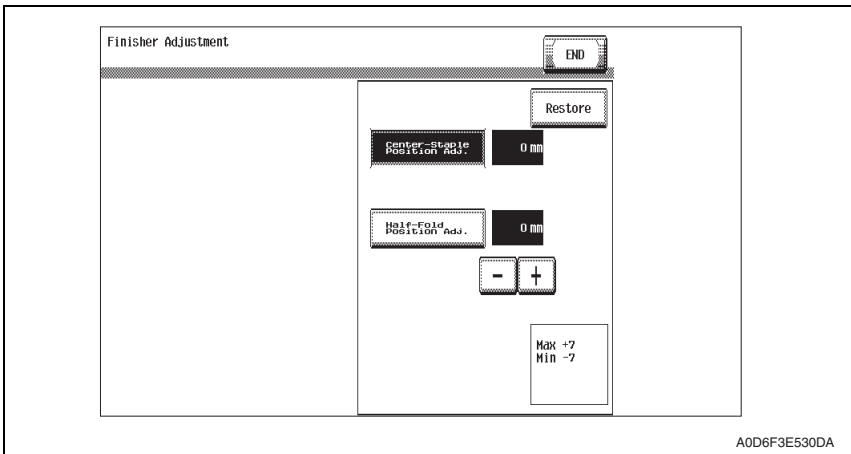

11. Adjust with the [+] / [-] Keys.

When the stapling position is shifted to the direction A: Adjust the value to the - side.

When the stapling position is shifted to the direction B: Adjust the value to the + side.

12. Touch [END].

13. Turn OFF the main power switch, then wait for 10 sec. or more and turn ON the main power switch.

14. Make the copy and check again.

### 5.1.2 Half-Fold Position Adj.

- The folding position is adjusted by aligning the folding position to the stapling position.
- This adjustment is made in the service mode of the main body. Since the adjustment is made in increments of 1 mm, this adjustment is useful for eliminating a displacement of 1 mm or more.
- For the effective adjustment of a minimal displacement smaller than 1 mm, refer to 6. Board switch.

See P.52

**Adjustment range: - 7 to + 7 mm (Increment: 1 mm)**

#### A. Adjustment procedure

1. Set A3 or 11 x 17 to the Feed Tray.
2. Touch these keys in this order: [Center Staple & Fold] → [OK].
3. Set five sheets of A3 or 11 x 17 original (blank paper acceptable) in the original tray.
- These five sheets are used for adjustment to minimize variation.
4. Press the start key.
5. Check the finished copies for deviation of the stapling position of from the newly folded position.

Take the top surface of the finished copies as A, and the under surface as B.

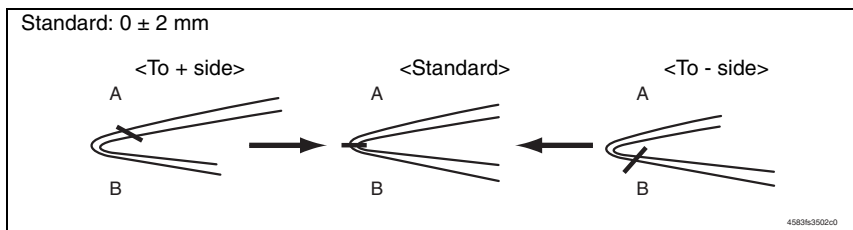

6. Set the mode to the service mode.  
See P.338 of the main body service manual.
7. Touch [Finisher].
8. Touch [FN-X3Adjustment].
9. Touch [Half-Fold Position Adj.]

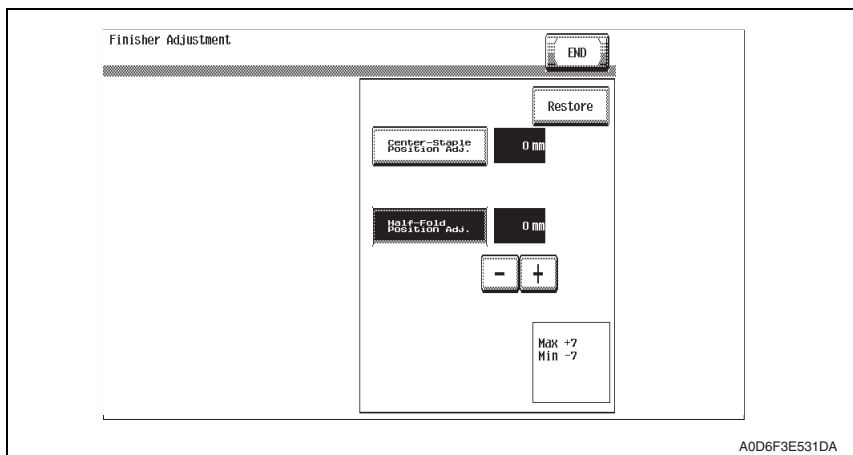

## 10. Adjust with the [+] / [-] Keys.

When the stapling position is shifted to the direction A: Adjust the value to the + side. When the stapling position is shifted to the direction B: Adjust the value to the - side.

## 11. Touch [END].

12. Turn OFF the main power switch, then wait for 10 sec. or more and turn ON the main power switch.

13. Make the copy and check again.

## 5.2 Punch option setting

Functions	<ul style="list-style-type: none"> <li>To set installation and model of the punch kit.</li> <li>To set the number of holes to be made by the punch kit installed.</li> </ul>
Use	<ul style="list-style-type: none"> <li>Use when the punch kit is installed.</li> </ul>
Setting/ Procedure	<ul style="list-style-type: none"> <li>The default setting is Non-installat.</li> </ul> <ol style="list-style-type: none"> <li>Touch [PK-501].</li> <li>Select the number of punch holes to be made corresponding to the model and destination.</li> <li>Touch [decision].</li> <li>Turn off the main power switch and turn it on again more than 10 seconds after.</li> </ol>

## 6. Mechanical adjustment

### 6.1 Adjustment of height and inclination

1. Gently move the finisher toward the machine and check for following.

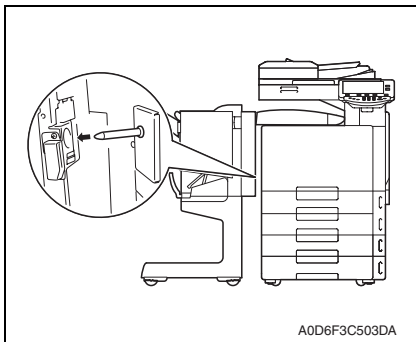

- Is the positioning pin aligned with the hole in the finisher?

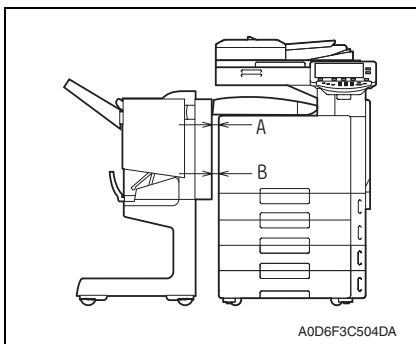

- Does the horizontal transport unit run excessively slantwise?
- Does the clearance at A equal that at B?

2. If the finisher is not at the same height as the machine, adjust the machine as follows.

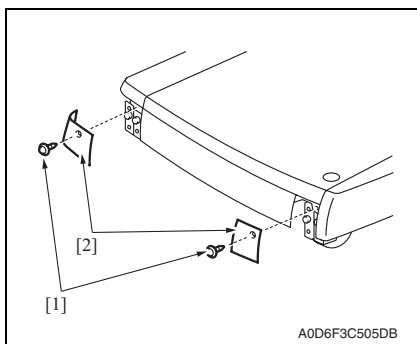

3. Remove the finisher from the main body, and remove two screws [1], and remove two caster covers [2].



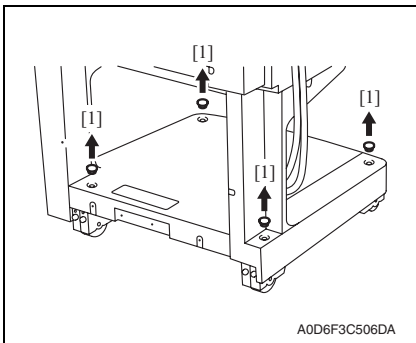

4. Remove four adjusting screw covers [1].

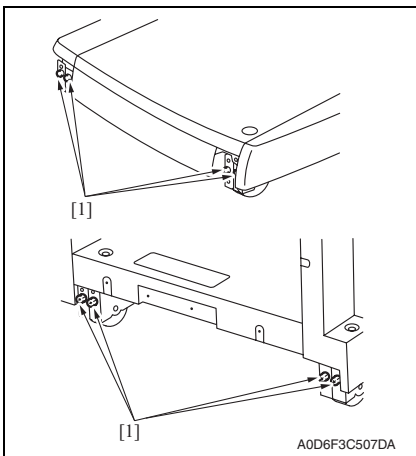

5. Loosen eight caster fixing screws [1].

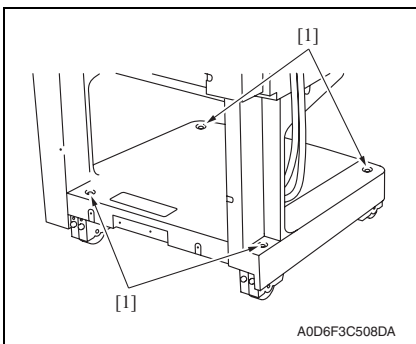

6. Turn four adjustment screws [1] to make adjustment.
  - To heighten: Turn the screw counter-clockwise.
  - To bring down: Turn the screw clockwise.

7. Fasten the caster fixing screws.
8. Install the caster covers and the adjustment screw covers.

## 6.2 Adjustment of the Folding Position

- Folding position is adjusted by adjusting the tray section and the saddle section.
- Adjust the folding position by aligning the tray section. Adjust the position of the saddle section if the position is still not proper.

<Deviation amount which will be adjusted>

Paper Size	Amount of deviation which will be adjusted by aligning the Tray Section	Amount of deviation which will be adjusted by aligning the Saddle Section position	Total amount which will be adjusted
A3	0.55 mm	0.55 mm	1.1 mm
A4	0.4 mm	0.4 mm	0.8 mm
B4	0.5 mm	0.5 mm	1.0 mm
Ledger	0.55 mm	0.55 mm	1.1 mm
Letter	0.35 mm	0.35 mm	0.7 mm

### 6.2.1 Adjustment procedure

#### A. Checking the deviation amount

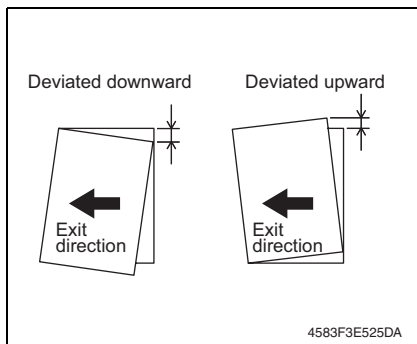

1. Load the paper take-up tray with A3 or 11x17 paper.
2. Select [Center Staple & Fold] and touch [OK].
3. Place the A3 original (blank paper acceptable) to the original tray, and press the start key.
4. Check the fed out copy to see if there is any deviation.

#### B. Adjusting the folding deviation

1. Turn main power switch OFF, and remove the Finisher from the machine.

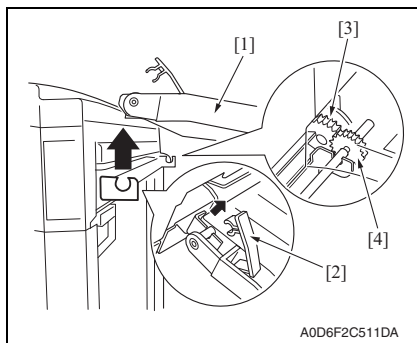

2. Raise the horizontal transport unit [1] straight upward and, keeping that condition, disengage the lock lever [2] and remove the horizontal transport unit [1].

**NOTE**

- At reinstallation, be sure to engage the lock lever [2] in position.
- At reinstallation, make sure that the gear [3] of the finisher is in positive mesh with the gear [4] of the horizontal transport unit.



- 3. Remove the middle transport unit.  
[See P.12](#)
- 4. Remove the front cover.  
[See P.7](#)

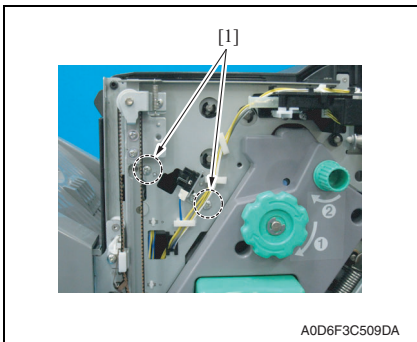

- 5. Loosen two screws [1] on the tray section.

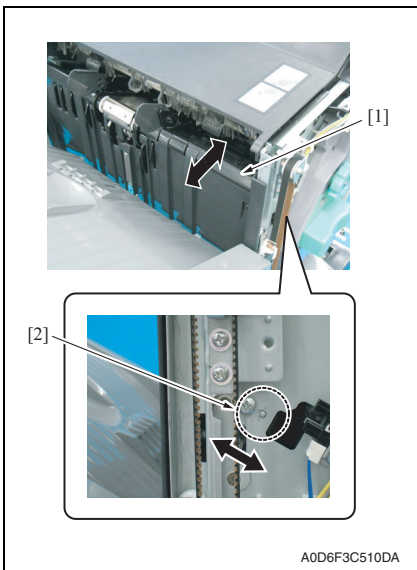

- 6. Move the tray section [1] back and forth, and move the positioning dowels [2] right and left to adjust.

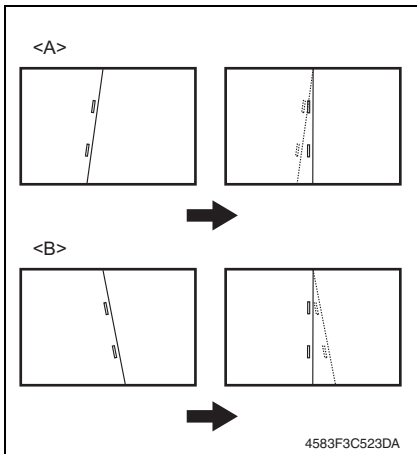

- If it is deviated downward <A>, move the positioning dowels to the left.
- If it is deviated upward <B>, move the positioning dowels to the right.

**NOTE**

- **The folding line will move along with the staples.**

7. Carry out the test copy to see if there is any folding deviation. If the deviation is not adjusted, repeat the procedure from step 8 to adjust the saddle section position.

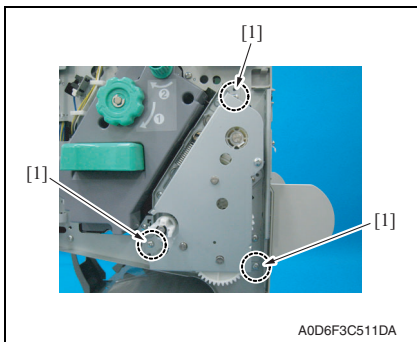

8. Loosen three set screws [1] on the saddle section.

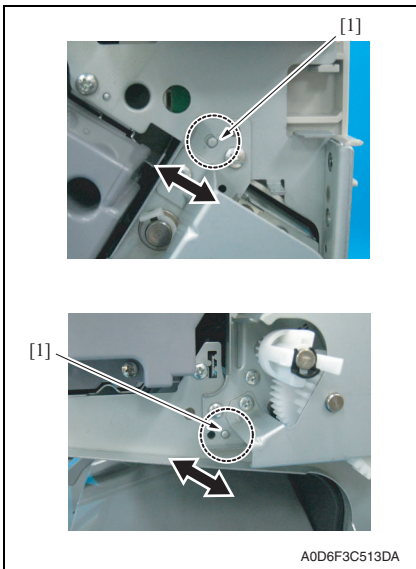

9. Move the two positioning dowels [1] to adjust.

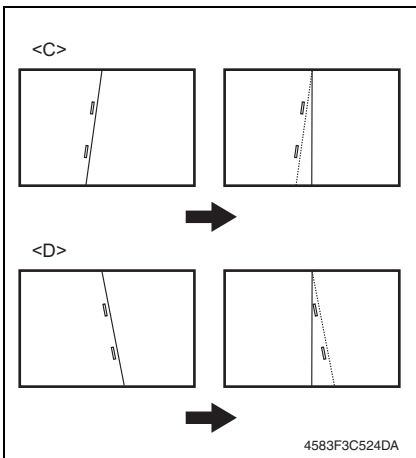

- If it is deviated downward <C>, move the positioning dowel to the left.
- If it is deviated upward <D>, move the positioning dowel to the right.

**NOTE**

- **Only the folding line will move.**

10. Feed out the test copy and check if there is any folding deviation.

### 6.3 Stapler phase adjustment

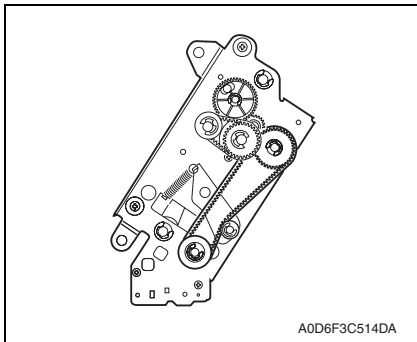

- Make phase adjustment of the stapler following the procedures given below whenever the gear or timing belt in front of the stapler has been replaced or removed for some reason, since such replacement or removal will cause mistiming between the staple driving by the staple driver (the lower unit of the stapler) and the staple clinching by the staple clincher (the upper unit of the stapler).

#### 6.3.1 Adjustment procedure

1. Remove the stapler.

See P.14

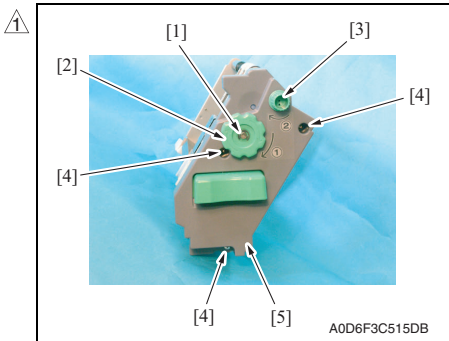

2. Remove the E-ring [1], and remove the jam release dial 1 [2].
3. Remove the jam release dial 2 [3].
4. Remove the three screws [4], and remove the stapler front cover [5].

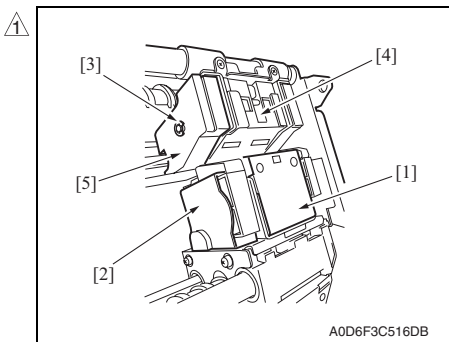

5. Remove the gear cover [2] from the staple driver [1].
6. Remove the E-ring [3], and remove the side cover [5] from the staple clincher [4].



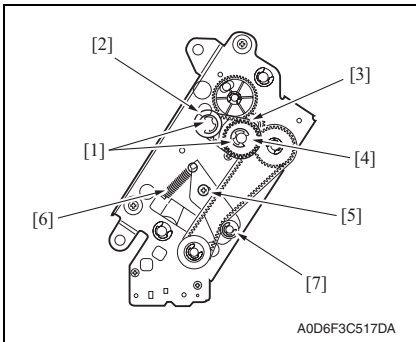

- 7. Remove two E-rings [1], and remove the staple jam release gear [2], the timing belt [3] and the middle gear 1 [4].
- 8. Remove the spacer and the spring located behind the staple jam release gear.
- 9. Remove the screw [5] and the spring [6], and remove the belt tension roller [7].

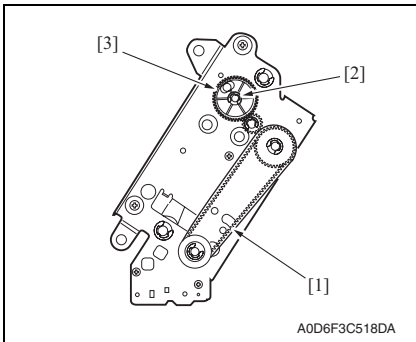

- 10. Remove the timing belt [1].
- 11. Remove the E-ring [2], and remove the staple position confirm gear [3].

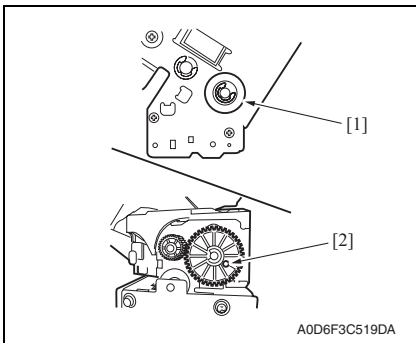

- 12. Turn the gear [1] to position the hole [2] in the gear of the staple driver to the hole behind.

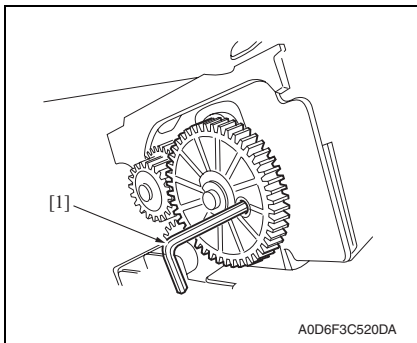

13. Insert a pin of approx.  $\phi 2$  [1] (alternatively, 2 mm hexagonal wrench or the like can be preferably used) into the hole, and fix the gear.

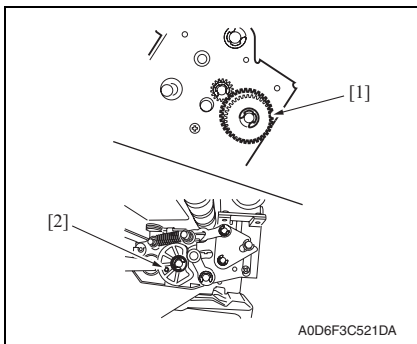

14. Turn the gear [1] to position the hole [2] in the cam of the staple clincher to the hole behind.

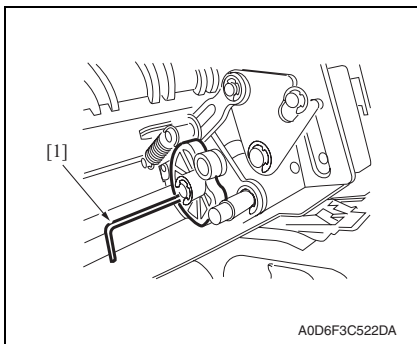

15. Insert a pin of approx.  $\phi 2$  [1] (alternatively, 2 mm hexagonal wrench or the like can be preferably used) into the hole, and fix the cam.

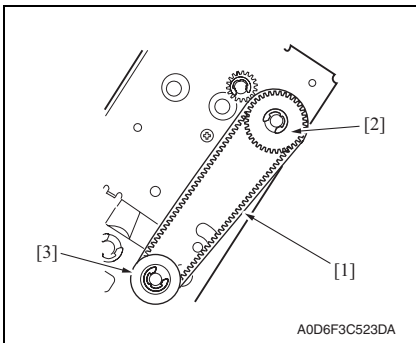

16. Set the timing belt [1] to the gear [2] and gear [3] with the gear and the cam in the fixed condition.

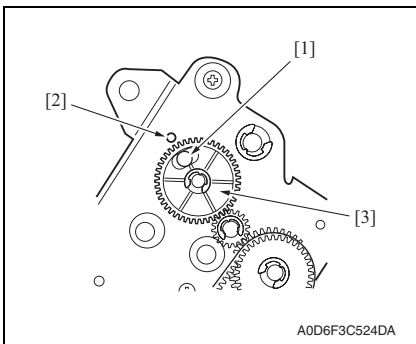

17. Install the staple position confirm gear [3] in such a way that the blue mark [1] of the gear comes face to face with the hole [2] in the frame.

**NOTE**

- The position in which the blue mark meets face to face with the hole is the home position for stapling. If the staple jam release gear is turned for some reason, this home position will shift and the staple cartridge will not come off. In this case, the staple position confirm gear plays a role of resuming the stapling home position by referring to the blue mark. Therefore, the gear should be set in place correctly.

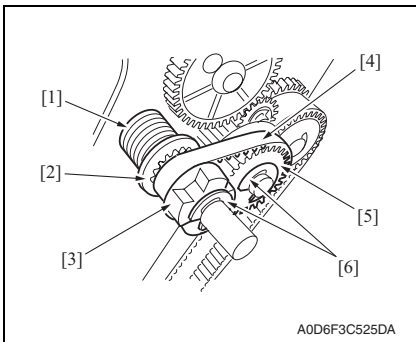

18. Remove the pin fixing the gear and the cam to release them.  
 19. Set the spring [1], the spacer [2], the staple jam release gear [3], the timing belt [4] and the middle gear 1 [5], and fix them with two E-rings [6].

### 6.4 Saddle gear phase adjustment

- Whenever the gear in front of the saddle or the folding roller has been replaced or removed for some reason, make gear phase adjustment following the procedures given below.

#### 6.4.1 Adjustment procedure

1. Remove the saddle.

See P.14

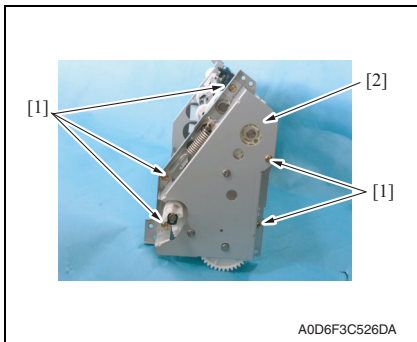

A0D6F3C526DA

2. Remove five screws [1], and remove the saddle gear cover [2].

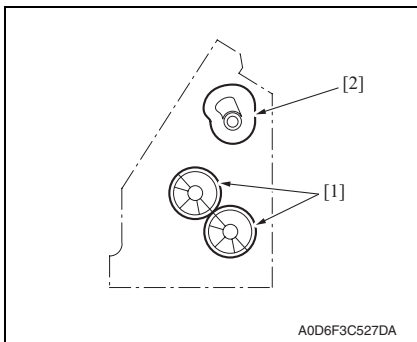

A0D6F3C527DA

3. Set the folding roller [1] and saddle cam [2] within the saddle as shown in the figure.
4. With the folding roller and the saddle cam positioned as shown in the left figure, set the gears as shown in the figure in the following way.

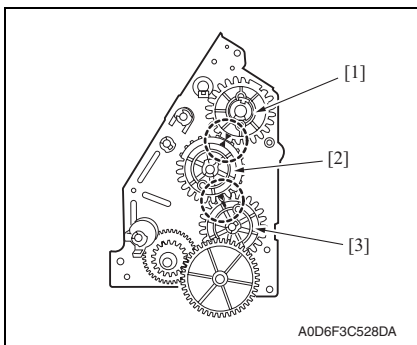

A0D6F3C528DA

#### NOTE

- The mark on the saddle cam drive gear [1] (either of the two marks) comes face to face with the mark on the middle gear [2] (the mark on the semi spherical part with narrow gear face width).
5. With the saddle cam drive gear [1] and the middle gear [2] positioned as above, the mark on the middle gear [2] (the mark on the other semi spherical part) meets face to face with the rib of the folding roller drive gear [3].



## 7. Board switch

### 7.1 FSCB (Finisher control board)

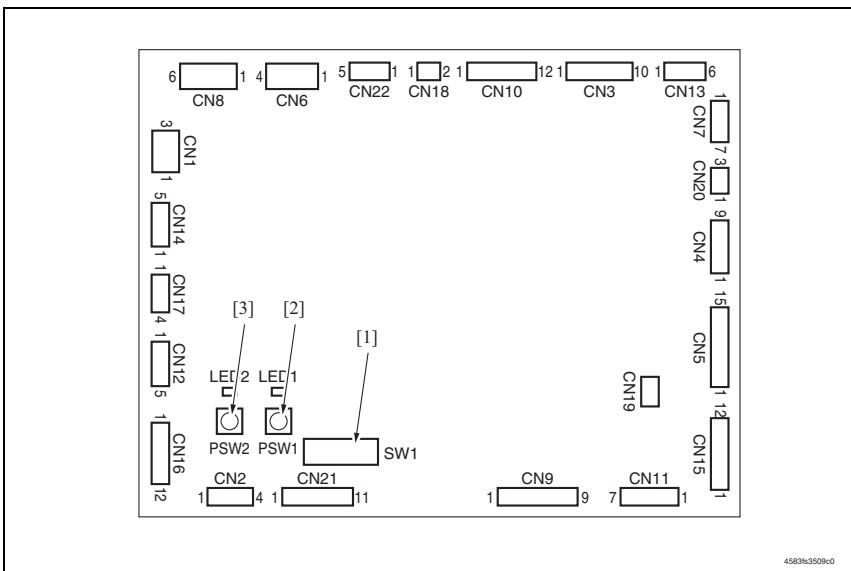

	Symbol	Description
[1]	SW1	Used to adjust the folding position, adjust the center 2-point stapling position and adjust the alignment plate position.
[2]	PSW1	Used to adjust the folding position, adjust the center 2-point stapling position and adjust the alignment plate position.
[3]	PSW2	Used to adjust the folding position, adjust the center 2-point stapling position and adjust the alignment plate position.

### 7.1.1 Adjustment of the folding positions

- When a folding position is adjusted, adjust the folding position to the stapling position. make this adjustment after replacing the finisher control board or when the folding position must be changed for some reason.

#### NOTE

- **Depending on the type of paper, both the folding position and the stapling position may be inaccurate. In this case, make adjustment independently from the finisher. In this independent adjustment from the finisher, set the adjustment value of [Center-Stapling Position Adj.] and [Half-Fold Position Adj.] in the service mode to  $\pm 0$  mm on the main body.**

1. Turn main power switch OFF, and remove the finisher from the machine.
2. Remove the rear cover from the finisher.

See P.8

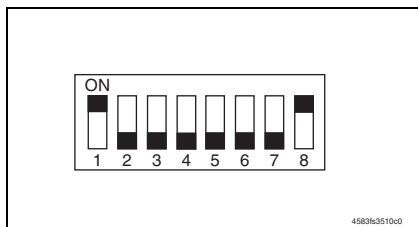

3. Set SW1 on the finisher control board as shown on the left figure.

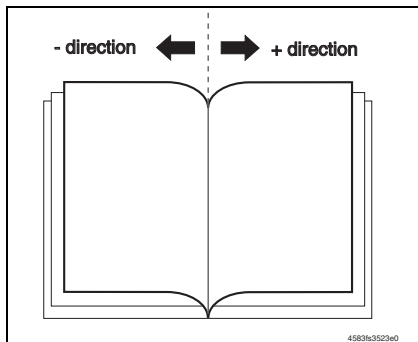

4. Press PSW1 or PSW2 on the finisher control board for the required times to adjust the folding position. One pressing of the switch moves the folding position by approx. 0.16 mm.
  - Press PSW1 to move the folding position in the - direction.
  - Press PSW2 to move the folding position in the + direction.
  - Press PSW1 and PSW2 simultaneously to clear the present set adjustment value.

5. After setting the adjustment value of the folding position, set all bits of SW1 on the finisher control board to OFF.
6. Perform the booklet creation on the main body, and confirm that the folding position has been correctly adjusted. If not, redo the adjustment.

### 7.1.2 Adjustment of the center stapling position

- When a stapling position is adjusted, adjust the stapling position to the folding position. Make this adjustment after replacing the finisher control board or when the stapling position must be changed for some reason.

#### NOTE

- Depending on the type of paper, both the folding position and the stapling position may be inaccurate. In this case, make adjustment independently from the finisher. In this independent adjustment from the finisher, set the adjustment value of [Center-Stapling Position Adj.] and [Half-Fold Position Adj.] in the service mode to  $\pm$  0mm on the main body.

- Turn main power switch OFF, and remove the finisher from the machine.
- Remove the rear cover from the finisher.

See P.8

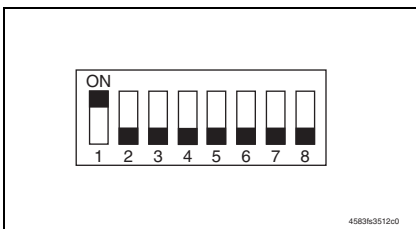

- Set SW1 on the finisher control board as shown on the left figure.

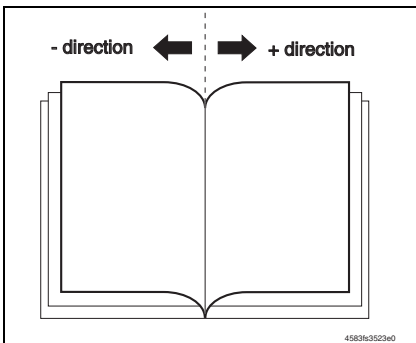

- Press PSW1 or PSW2 on the finisher control board for the required times to adjust the stapling position. One pressing of the switch moves the stapling position by approx. 0.14 mm.
  - Press PSW1 to move the stapling position in the - direction.
  - Press PSW2 to move the stapling position in the + direction.
  - Press PSW1 and PSW2 simultaneously to clear the present set adjustment value.

- After setting the adjustment value of the stapling position, set all bits of SW1 on the finisher control board to OFF.
- Perform the booklet creation on the main body, and confirm that the stapling position has been correctly adjusted. If not, redo the adjustment.

### 7.1.3 Adjustment of the alignment plate position

- Alignment plate should be adjusted when there is a faulty alignment, the staple position deviates.

#### A. Alignment procedure

##### NOTE

- If a step or steps are wrongly performed in mid procedure, stop the procedure immediately. Then turn OFF the main power switch of the main body, wait for 10 sec. or more, and turn ON the main power switch. After performing these steps, start the procedure over.

1. Turn main power switch OFF, and remove the finisher from the machine.
2. Remove the rear cover from the finisher.

See P.8

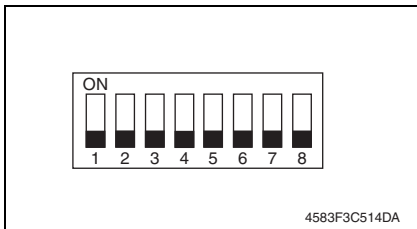

3. Check to make sure that all SW1 on the finisher controller board are set to OFF.

##### NOTE

- When not all of them are OFF, write down the switch status and turn them OFF.

4. With the rear cover of the finisher removed, install the finisher to the machine, and turn main power switch ON.

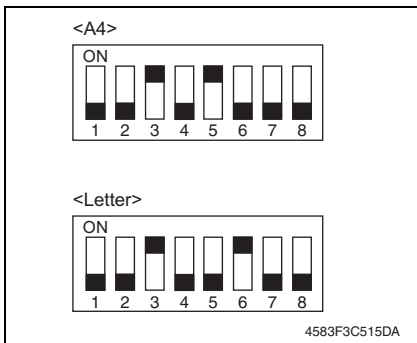

5. When the initial operation of the finisher is complete, turn on the following switches of SW1.  
When adjusting with A4: 3, 5  
When adjusting with Letter: 3, 6

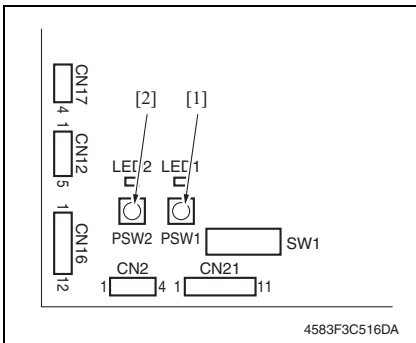

6. After the initial operation of the finisher, press the PSW1 [1] on the finisher control board and make sure that the alignment plate moves to the selected paper size area.
7. Adjust the alignment plate position with PSW1 [1] or PSW2 [2].  
When adjusting inward: Press PSW1.  
When adjusting outward: Press PSW2.

**The alignment plate will move 0.367mm every time the push switch is pressed.**  
**Alignment range is ± 2.936 mm.**

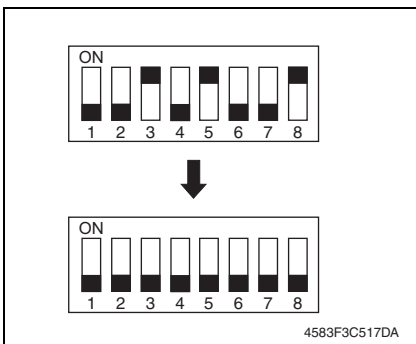

8. When the adjustment is complete, turn switch 8 of SW1 ON to set the adjustment value.
9. Turn all adjustment switches OFF.
10. Turn main power switch OFF.

**NOTE**

- When not all SW1 are OFF in step 3, return to the original condition according to the written note.

11. Return the finisher to the original status.

## 7.2 PKCB (Punch control board)

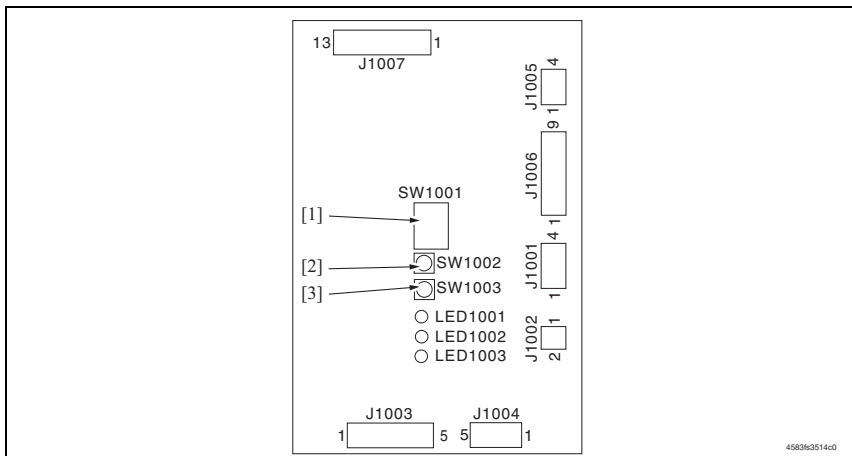

	Symbol	Description
[1]	SW1001	Used to register the number of punched holes and adjust the sensor output.
[2]	SW1002	Used to register the number of punched holes and adjust the sensor output.
[3]	SW1003	Used to register the number of punched holes and adjust the sensor output.

### 7.2.1 Adjustment of the sensor output

- Be sure to make this adjustment after replacing the punch control board, the side registration sensor (Photosensor board or LED board) or the punch dust full sensor (punch dust full sensor board or punch dust full LED board).

- Turn main power switch OFF, and remove the finisher from the machine.
- Remove the rear cover from the finisher.

See P.8

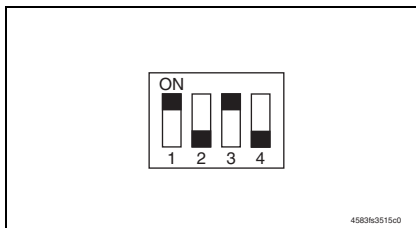

- Set the bits 1 through 4 of DIPSW1001 on the punch control board as shown on the left figure.
- Press SW1002 or SW1003 on the punch control board. The sensor output will be automatically adjusted.
- When all LED1001, LED1002 and LED1003 light up, the adjustment has been completed.
- Set all bits of DIPSW1001 to OFF.

**7.2.2 Registration of the number of punch holes**

- In order for the finisher to recognize the number of punch holes that can be achieved by the installed punch unit, such number of punch holes is registered in the IC on the punch control board. Make this registration whenever the punch control board has been replaced.
- However, this registration is not necessary if the EEP-ROM used on an old board has been reinstalled to a new board.

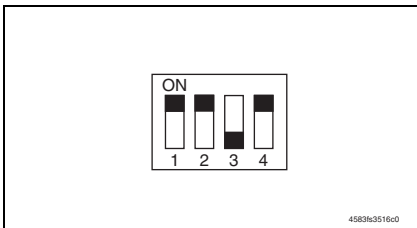

1. Set the bits 1 through 4 of DIPSW1001 on the punch control board as shown on the left figure.

2. Press SW1002 on the punch control board to select the number of punch holes.
- Each time SW1002 is pressed, the following display changes in the descending order shown below:

Number of punch holes	LED 1001	LED 1002	LED 1003
2 (Punch unit J1)	ON	OFF	OFF
2/3 (Punch unit K1)	ON	ON	OFF
4 (Punch unit G1)	OFF	ON	OFF
4 (Punch unit H1)	OFF	OFF	ON

3. Press SW1003 on the punch control board twice. The number of punch holes will be registered in the punch control board.
- The pressing of SW1003 changes the steady lighting of the LED to flickering, and the pressing of SW1003 again changes the flickering of the LED to steady lighting. This completes the registration.
4. Set all bits of DIPSW1001 to OFF.

### 7.2.3 Procedure after replacing the EEPROM (IC1002)

1. Turn OFF the main power switch of the main body.

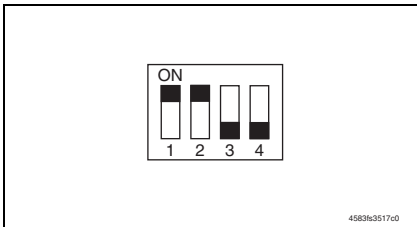

2. Set the bits 1 through 4 of DIPSW1001 on the punch control board as shown on the left figure.
3. Press SW1002 and SW1003 on the punch control board simultaneously.
  - This will initialize the EEPROM. After the initialization, all LED1001, LED1002 and LED1003 light up.
4. Adjust the sensor output, and register the number of punch holes.
5. Set all bits of DIP SW 1001 to OFF.

### 7.2.4 Punch center position adjustment

- This adjustment is made when the punch lateral movement is changed from the lateral registration motion (automatic through end face detection) to fixed system based on the paper size.

1. Turn main power switch OFF, and remove the finisher from the machine.
2. Remove the rear cover from the finisher.

See P.8

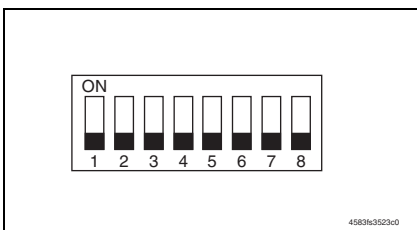

3. Check that all keys of SW1 of the finisher control board are OFF.
4. Turn ON the main power switch of the main body and wait until the finisher completes its initial operation.

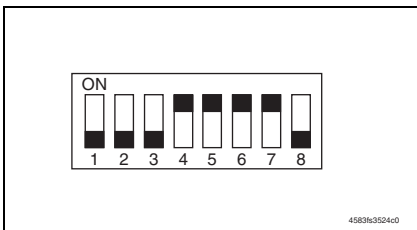

- Use the following procedure to clear the adjustment of the punch lateral movement.
5. Turn ON keys 4, 5, 6, and 7 of SW1 of the finisher control board.

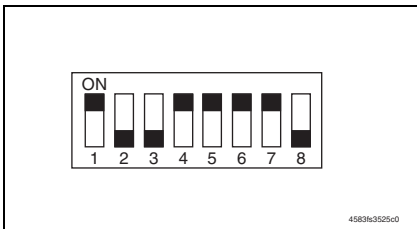

6. Turn ON key 1 of SW1 of the finisher control board.
7. Press PSW1 and PSW2 of the finisher control board at the same time.



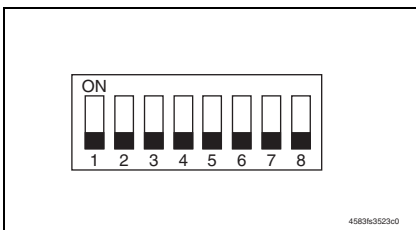
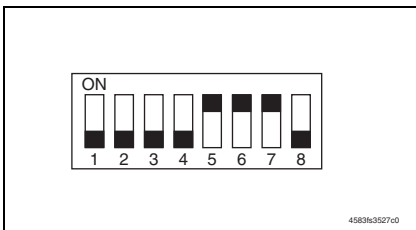
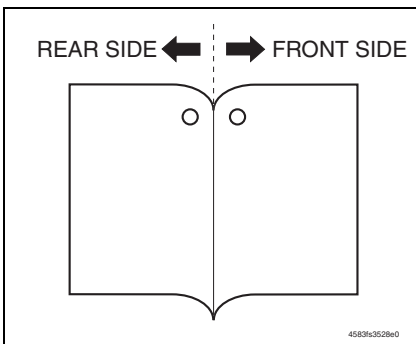
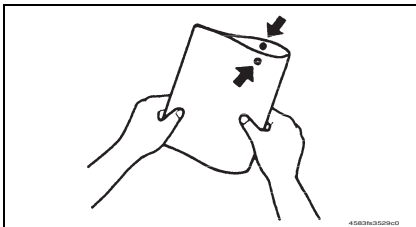
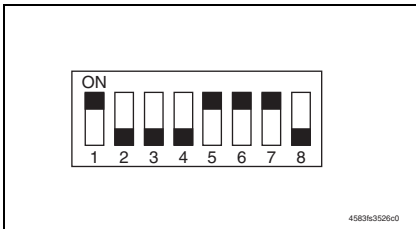

8. Turn OFF key 4 of SW1 of the finisher control board.
9. Wait until the machine becomes capable of paper feed.

10. Feed one sheet of paper through the machine. Fold the copy fed out of the machine in half and check that the punch holes are aligned with each other.  
Specifications:  $0 \pm 2$  mm
- If the specified range is not met, use the following procedure to adjust the punch center position.

11. Press PSW1 or PSW2 of the finisher control board once according to the direction of deviation.
- Pressing PSW1 moves the punch position to the front.
- Pressing PSW2 moves the punch position to the rear.
- Each press of PSW1 or PSW2 moves the position 1 mm. The adjustment range should be within  $\pm 5$  mm.
12. Feed another sheet of paper. If the punch hole position is not properly adjusted, make the adjustment once again.

- When the adjustment procedure has been completed, use the following procedure to finish the adjustment mode.
13. Turn OFF key 1 of SW1 of the finisher control board.

14. Turn OFF keys 5, 6, and 7 of SW1 of the finisher control board.
15. Turn OFF the main power switch of the main body.

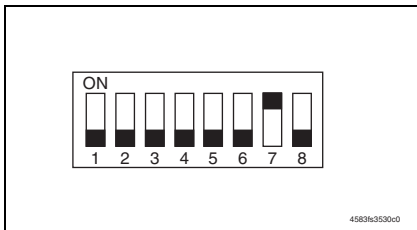

16. Turn ON key 7 of SW1 of the finisher control board.

**NOTE**

- Flipping ON key 7 of SW1 validates the setting made to the fixed system based on the paper size as changed from the lateral registration motion (automatic through end face detection).
- To return the setting back to the lateral registration motion, flip OFF key 7 of SW1.

17. Turn ON the main power switch of the main body.

18. Reinstall the rear cover.

[See P.8](#)

**NOTE**

- The procedure must be carried out as specified. In particular, switching ON or OFF must be performed properly.
- If a step or steps are wrongly performed in mid procedure, stop the procedure immediately. Then turn OFF the main power switch of the main body, wait for 10 sec. or more, and turn ON the main power switch. After performing these steps, start the procedure over.
- This adjustment is applicable only to the punch position center adjustment. The adjustment range is  $\pm 5$  mm. It does not adjust for variations in the punch hole positions.

Blank Page

# Troubleshooting

## 8. Jam display

### 8.1 Misfeed display

- When misfeed occurs, message, misfeed location “Blinking” and paper location “Lighting” are displayed on the touch panel of the main body.

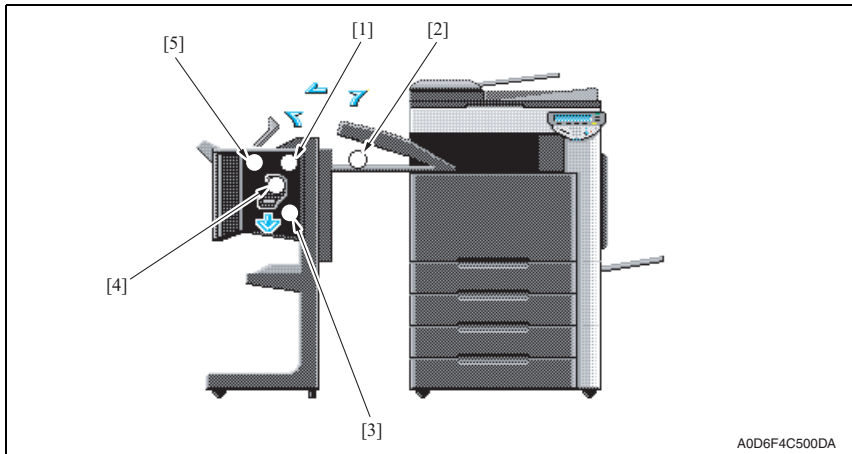

No.	Code	Misfeed location	Misfeed access location	Action
[1]	7218	Transport section	Front door	<a href="#">P.66</a>
[2]	7216	Horizontal transport section	Horizontal transport cover	<a href="#">P.66</a>
[3]	7225	Folding position section	Front door	<a href="#">P.67</a>
[4]	7281	Stapler section	Front door	<a href="#">P.67</a>
[5]	7221	Paper stack exit section	Front door	<a href="#">P.68</a>

#### 8.1.1 Misfeed display resetting procedure

- Open the corresponding door, clear the sheet of paper misfeed, and close the door.

## 8.2 Sensor layout

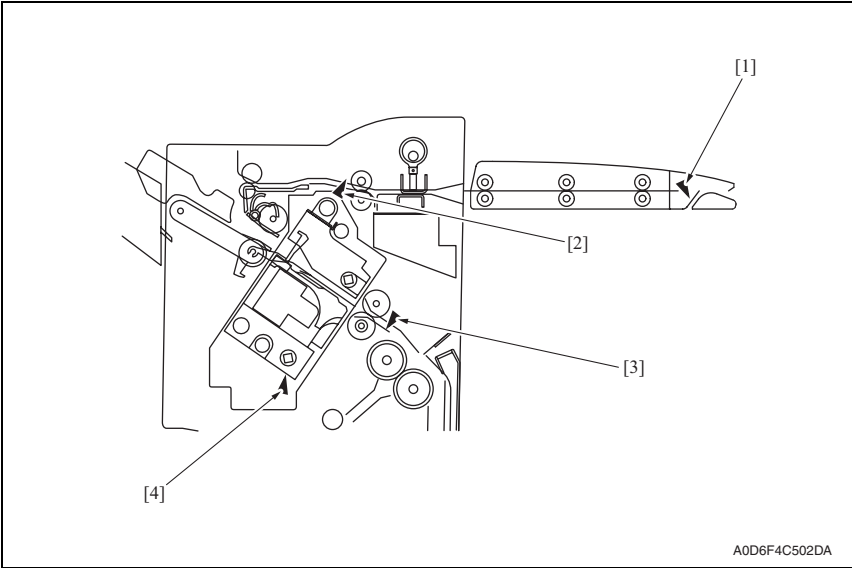

A0D6F4C502DA

- |                           |      |  |      |
|---------------------------|------|--|------|
| [1] Turnover empty sensor | PS27 | [3] Folding position sensor            | PS10 |
| [2] Entrance sensor       | PS1  | [4] Stapler drive home position sensor | PS19 |

### 8.3 Solution

#### 8.3.1 Initial check items

- When a paper misfeed occurs, first perform the following initial check items.

Check Item	Action
Does the paper meet product specifications?	Change the paper.
Is paper curled, wavy, or damp?	See "Solution when paper curl occurs" on P.65.
Is a foreign object present along the paper path, or is the paper path deformed or worn?	Clean or change the paper path.
Are the rolls/rollers dirty, deformed, or worn?	Clean or change the defective roll/roller.
Are the edge guide and trailing edge stop at the correct position to accommodate the paper?	Set as necessary.
Are the actuators found operational when checked for correct operation?	Correct or change the defective actuator.

#### 8.3.2 Solution when paper curl occurs

Step	Check items/actions	OK	—
1	Turn over the stacked paper in the paper tray.	OK	—
		NG	Go to step 2.
2	Does paper curl occur just after a warm-up has been completed or the sleep mode has been turned OFF?	YES	Go to step 3.
	Does paper curl occur under normal conditions (under conditions other than those mentioned above)?	YES	Go to step 5.
3	1. Call the Service Mode to the screen. 2. Select [System 1] → [Change Warm Up Time]. 3. Change the setting to [Mode3]. See P.393 of the main body service manual.	OK	—
		NG	Go to step 4.
4	1. Call the Service Mode to the screen. 2. Select [System 1] → [Change Warm Up Time]. 3. Change the setting to [Mode4]. See P.393 of the main body service manual.	—	—
5	1. Call the Service Mode to the screen. 2. Select [Machine] → [Fusing Temperature]. 3. Select a paper type. 4. Change the temperature of Heater Roller to [-10 °C]. See P.345 of the main body service manual.	OK	—
		NG	Go to step 6
6	1. Call the Service Mode to the screen. 2. Select [Machine] → [Fusing Temperature]. 3. Select a paper type. 4. Change the temperature of Heater Roller to [-20 °C]. See P.345 of the main body service manual.	—	—

**8.3.3 Transport section misfeed**

**A. Detection timing**

Type	Description
Transport section misfeed detection	The entrance sensor (PS1) does not detect paper even after the lapse of approx. 1.5 sec. after the entrance sensor (PS1) has received the paper exit signal from the main body.
	Paper is not removed from the entrance sensor (PS1) even after the lapse of approx. 2 sec. after the entrance sensor (PS1) has detected paper edge.

**B. Action**

Relevant electrical parts	
Entrance sensor (PS1)	Finisher control board (FSCB)



Step	Action	WIRING DIAGRAM	
		Control signal	Location (Electrical components)
1	Initial check items	—	—
2	PS1 I/O, sensor check	FSCB CN16-11 (ON)	FS-609/PK-501 C-11
3	FSCB replacement	—	—

**8.3.4 Horizontal transport section misfeed**

**A. Detection timing**

Type	Description
Horizontal transport section misfeed detection	The turnover empty sensor (PS27) is not unblocked even after the lapse of a given period of time after the leading edge of the paper has blocked the turnover empty sensor (PS27).

**B. Action**

Relevant electrical parts	
Turnover empty sensor (PS27)	Finisher control board (FSCB)



Step	Action	WIRING DIAGRAM	
		Control signal	Location (Electrical components)
1	Initial check items	—	—
2	PS27 I/O, sensor check	FSCB CN21-5 (ON)	FS-609/PK-501 I-10
3	FSCB replacement	—	—

### 8.3.5 Folding position section misfeed

#### A. Detection timing

Type	Description
Folding position section misfeed detection	The folding position sensor (PS10) does not detect paper even after the set period of time after the paper has been fed from the transport booklet tray to the stapling position during stapling operation.
	Paper is not removed from the folding position sensor (PS10) even after the lapse of approx. 10.5 sec. after the staple/folding motor (M7) has been driven during stapling operation.

#### B. Action

Relevant electrical parts	
Folding position sensor (PS10)	Finisher control board (FSCB)



Step	Action	WIRING DIAGRAM	
		Control signal	Location (Electrical components)
1	Initial check items	—	—
2	PS10 I/O, sensor check	FSCB CN16-2 (ON)	FS-609/PK-501 C-12
3	FSCB replacement	—	—

### 8.3.6 Stapler section misfeed

#### A. Detection timing

Type	Description
Stapler section misfeed detection	The stapler drive home position sensor (PS19) is not turned OFF or does not return to its home position even after the set period of time after the stapler has been driven.

#### B. Action

Relevant electrical parts	
Stapler drive home position sensor (PS19)	Finisher control board (FSCB)

Step	Action	WIRING DIAGRAM	
		Control signal	Location (Electrical components)
1	Initial check items	—	—
2	PS19 I/O, sensor check	—	—
3	FSCB replacement	—	—



**8.3.7 Paper stack exit section misfeed****A. Detection timing**

Type	Description
Paper stack exit section misfeed detection	The finisher tray sensor (PS6) remains activated when a copy stack, which has been stapled together, is fed out.

**B. Action**

Relevant electrical parts	
Exit motor (M3) Finisher tray sensor (PS6)	Finisher control board (FSCB)



Step	Action	WIRING DIAGRAM	
		Control signal	Location (Electrical components)
1	Initial check items	—	—
2	PS6 I/O, sensor check	FSCB CN5-3 (ON)	FS-609/PK-501 I-7
3	M3 operation check	FSCB CN13-3 to 6	FS-609/PK-501 C-6
4	FSCB replacement	—	—

## 9. Trouble code

### 9.1 Trouble code display

- The main unit's CPU performs a self-diagnostics function that, on detecting a malfunction, gives the corresponding malfunction code on the touch panel.

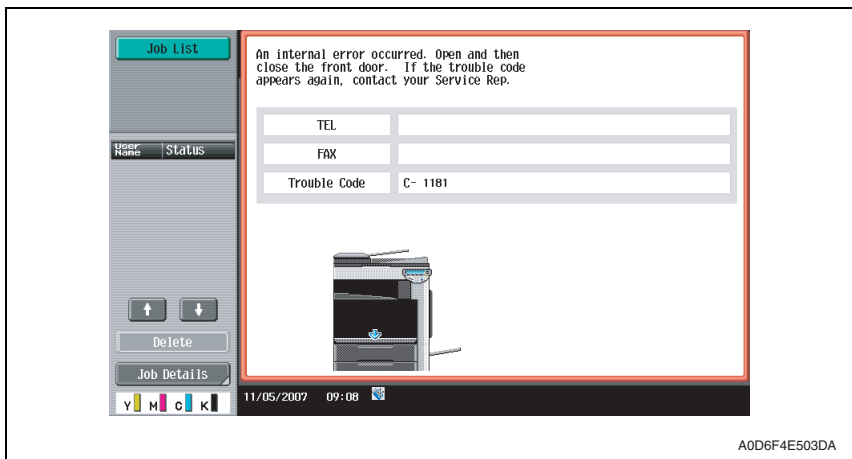

#### NOTE

- Before starting the troubleshooting in relation to the punch mechanism C11CX, be sure to turn OFF the main power switch of the machine.

### 9.2 Trouble code list

Code	Item	Description
C1180	Transport system drive malfunctions	<ul style="list-style-type: none"> <li>The folding roller home position sensor (PS12) is not unblocked even after the lapse of a given period of time after the folding roller has started moving from its home position.</li> <li>The folding roller home position sensor (PS12) is not blocked even after the lapse of a given period of time after the folding roller has started moving from a position not the home position.</li> </ul>
C1181	Paddle motor malfunctions	<ul style="list-style-type: none"> <li>The paddle home position sensor (PS2) is not unblocked even after the lapse of a given period of time after the paddle has started moving from its home position.</li> <li>The paddle home position sensor (PS2) is not blocked even after the lapse of a given period of time after the paddle has started moving from a position not the home position.</li> <li>The bundle exit roller home position sensor (PS3) is not unblocked even after the lapse of a given period of time after the booklet roller has started moving from its home position.</li> <li>The bundle exit roller home position sensor (PS3) is not blocked even after the lapse of a given period of time after the booklet roller has started moving from a position not the home position.</li> </ul>

Code	Item	Description
C1183	Elevate mechanism malfunctions	<ul style="list-style-type: none"> <li>• The exit tray home position sensor (PS9) is not blocked even after the lapse of a given period of time after the tray has started moving up.</li> <li>• An encoder clock input is not detected within a given period of time during operation of the tray.</li> </ul>
C1192	Front aligning plate motor malfunctions	<ul style="list-style-type: none"> <li>• The front aligning plate home position sensor (PS4) is not unblocked even after the lapse of a given period of time after the front aligning plate has started moving from its home position to a position out of the home position.</li> <li>• The front aligning plate home position sensor (PS4) is not blocked even after the lapse of a given period of time after the front aligning plate has started moving from a position out of the home position to the home position.</li> </ul>
C1193	Rear aligning plate motor malfunctions	<ul style="list-style-type: none"> <li>• The rear aligning plate home position sensor (PS5) is not unblocked even after the lapse of a given period of time after the rear aligning plate has started moving from its home position to a position out of the home position.</li> <li>• The rear aligning plate home position sensor (PS5) is not blocked even after the lapse of a given period of time after the rear aligning plate has started moving from a position out of the home position to the home position.</li> </ul>
C11A4	Booklet exit motor malfunctions	<ul style="list-style-type: none"> <li>• The exit belt home position sensor (PS7) is not unblocked even after the lapse of a given period of time after the booklet exit belt has started moving from its home position during an initial operation.</li> <li>• The exit belt home position sensor (PS7) is not unblocked even after the lapse of a given period of time after the booklet exit belt has started moving from its home position during an ordinary operation.</li> <li>• The exit belt home position sensor (PS7) is not blocked even after the lapse of a given period of time after the booklet exit belt has started moving from a position not the home position during an initial operation.</li> <li>• The exit belt home position sensor (PS7) is not blocked even after the lapse of a given period of time after the booklet exit belt has started moving from a position not the home position during an ordinary operation.</li> </ul>
C11B1	Stapler unit slide motor malfunctions	<ul style="list-style-type: none"> <li>• The slide home position sensor (PS18) is not unblocked even after the lapse of a given period of time after the stapler unit has started moving from its home position.</li> <li>• The slide home position sensor (PS18) is not blocked even after the lapse of a given period of time after the stapler unit has started moving from a position not the home position.</li> </ul>

Code	Item	Description
C11B4	Stapler/folding motor malfunctions	<ul style="list-style-type: none"> <li>The stapler drive home position sensor (PS19) is not blocked even after the lapse of a given period of time after the clinch operation has started.</li> <li>An encoder clock input is not detected within a given period of time during a clinch operation.</li> <li>The folding home position sensor (PS11) is not blocked even after the lapse of a given period of time after the folding unit has started moving from a position out of the home position during an initial operation.</li> <li>The folding home position sensor (PS11) is not unblocked even after the lapse of a given period of time after a folding operation has been started during an ordinary operation.</li> <li>The folding home position sensor (PS11) is not blocked even after the lapse of a given period of time after a folding operation has been started and the sensor has been unblocked during an ordinary operation.</li> <li>An encoder clock input is not detected within a given period of time during a folding operation.</li> </ul>
C11C1	Punch control board malfunctions	<ul style="list-style-type: none"> <li>No response is received to a request made by the finisher within a given period of time during initial communications.</li> <li>No response is received to a request made by the finisher within a given period of time during ordinary communications.</li> <li>There is no match in the checksum values of the backup data as checked twice.</li> <li>The 24 V power source of the punch unit is OFF when an operation request is made from the finisher.</li> </ul>
C11C2	Punch side registration motor malfunctions	<ul style="list-style-type: none"> <li>The side registration home sensor (PS2) is not unblocked even after the lapse of a given period of time after the punch side registration unit has started moving from its home position.</li> <li>The side registration home sensor (PS2) is not blocked even after the lapse of a given period of time after the punch side registration unit has started moving from a position not the home position.</li> </ul>
C11C3	Punch motor malfunctions	<ul style="list-style-type: none"> <li>The home position is not detected within a given period of time after the punch motor has been rotated a half turn.</li> <li>An encoder clock input is not detected even after the lapse of a given period of time during operation of the punch motor.</li> <li>The setting value calculated during the initial operation falls outside the threshold value range.</li> </ul>
C11C5	Punch sensor malfunctions	<ul style="list-style-type: none"> <li>The light receiving voltage is 2.5 V or less when the illuminating voltage is set to 4.4 V.</li> <li>The light receiving voltage is 2.5 V or more when the illuminating voltage is set to 0 V.</li> <li>The illuminating voltage setting is 4.4 V or more after the adjustment has been made.</li> </ul>
C1401	Backup RAM malfunction	<ul style="list-style-type: none"> <li>Data written in the backup memory differs from what is recorded in it and writing operation is not correctly performed even with two retry sequences (a total of three writing sequences).</li> </ul>

**NOTE**

- The punch unit detects punch-related malfunctions and notifies the finisher of any malfunction detected.**

### 9.3 Solution

#### 9.3.1 C1180: Transport system drive malfunctions

Relevant electrical parts	
Folding roller home position sensor (PS12) Transport motor (M1)	Finisher control board (FSCB)

Step	Action	WIRING DIAGRAM	
		Control signal	Location (Electrical components)
1	Check the motor connectors for proper connection, and correct as necessary.	—	—
2	Check the connector of motor for proper drive coupling, and correct as necessary.	—	—
3	PS12 I/O, sensor check	FSCB CN16-9 (ON)	FS-609/PK-501 C-11
4	M1 operation check when the main power switch is turned OFF and ON.	FSCB CN10-3 to 6	FS-609/PK-501 C-8 to 9
5	FSCB replacement	—	—

#### 9.3.2 C1181: Paddle motor malfunctions

Relevant electrical parts	
Paddle home position sensor (PS2) Bundle exit roller home position sensor (PS3) Paddle motor (M2)	Finisher control board (FSCB)

Step	Action	WIRING DIAGRAM	
		Control signal	Location (Electrical components)
1	Check the motor and sensor connectors for proper connection, and correct as necessary.	—	—
2	Check the connector of motor for proper drive coupling, and correct as necessary.	—	—
3	PS2 I/O, sensor check	FSCB CN9-2 (ON)	FS-609/PK-501 I-12
4	PS3 I/O, sensor check	FSCB CN9-8 (ON)	FS-609/PK-501 I-12
5	M2 operation check when the main power switch is turned OFF and ON.	FSCB CN10-9 to 12	FS-609/PK-501 C-9
6	FSCB replacement	—	—

**9.3.3 C1183: Elevate mechanism malfunctions**

**(1) Upper limit sensor**

Relevant electrical parts	
Lift upper limit sensor (PS15)	Finisher control board (FSCB)



Step	Action	WIRING DIAGRAM	
		Control signal	Location (Electrical components)
1	Check the sensor connectors for proper connection, and correct as necessary.	—	—
2	PS15 I/O, sensor check	FSCB CN15-12 (ON)	FS-609/PK-501 I-7
3	FSCB replacement	—	—

**9.3.4 C1192: Front aligning plate motor malfunctions**

Relevant electrical parts	
Front aligning plate home position sensor (PS4) Front aligning motor (M4)	Finisher control board (FSCB)



Step	Action	WIRING DIAGRAM	
		Control signal	Location (Electrical components)
1	Check the motor and sensor connectors for proper connection, and correct as necessary.	—	—
2	Check the connector of motor for proper drive coupling, and correct as necessary.	—	—
3	PS4 I/O, sensor check	FSCB CN4-2 (ON)	FS-609/PK-501 I-8 to 9
4	M4 operation check when the main power switch is turned OFF and ON.	FSCB CN3-2 to 5	FS-609/PK-501 C-5
5	FSCB replacement	—	—

**9.3.5 C1193: Rear aligning plate motor malfunctions**

Relevant electrical parts	
Rear aligning plate home position sensor (PS5) Rear aligning motor (M5)	Finisher control board (FSCB)

Step	Action	WIRING DIAGRAM	
		Control signal	Location (Electrical components)
1	Check the motor and sensor connectors for proper connection, and correct as necessary.	—	—
2	Check the connector of motor for proper drive coupling, and correct as necessary.	—	—
3	PS5 I/O, sensor check	FSCB CN5-15 (ON)	FS-609/PK-501 I-8
4	M5 operation check when the main power switch is turned OFF and ON.	FSCB CN3-7 to 10	FS-609/PK-501 C-5 to 6
5	FSCB replacement	—	—

**9.3.6 C11A4: Booklet exit motor malfunctions**

Relevant electrical parts	
Exit belt home position sensor (PS7) Exit motor (M3)	Finisher control board (FSCB)

Step	Action	WIRING DIAGRAM	
		Control signal	Location (Electrical components)
1	Check the motor and sensor connectors for proper connection, and correct as necessary.	—	—
2	Check the connector of motor for proper drive coupling, and correct as necessary.	—	—
3	PS7 I/O, sensor check	FSCB CN5-6 (ON)	FS-609/PK-501 I-7
4	M3 operation check when the main power switch is turned OFF and ON.	FSCB CN13-3 to 6	FS-609/PK-501 C-6
5	FSCB replacement	—	—

**9.3.7 C11B1: Stapler unit slide motor malfunctions**

Relevant electrical parts	
Slide home position sensor (PS18) Slide motor (M8)	Finisher control board (FSCB)



Step	Action	WIRING DIAGRAM	
		Control signal	Location (Electrical components)
1	Check the motor and sensor connectors for proper connection, and correct as necessary.	—	—
2	Check the connector of motor for proper drive coupling, and correct as necessary.	—	—
3	PS18 I/O, sensor check	FSCB CN11-3	FS-609/PK-501 C to D-7
4	M8 operation check when the main power switch is turned OFF and ON.	FSCB CN7-3 to 6	FS-609/PK-501 C-6 to 7
5	FSCB replacement	—	—

**9.3.8 C11B4: Stapler/folding motor malfunctions**

**(1) Wiring**

Relevant electrical parts	
Stapler drive home position sensor (PS19) staple/folding motor (M7)	Finisher control board (FSCB)



Step	Action	WIRING DIAGRAM	
		Control signal	Location (Electrical components)
1	Check the motor connectors for proper connection, and correct as necessary.	—	—
2	Check the connector of motor for proper drive coupling, and correct as necessary.	—	—
3	PS19 I/O, sensor check	—	—
4	M7 operation check when the main power switch is turned OFF and ON.	FSCB CN6-3 to 4	FS-609/PK-501 C-4
5	FSCB replacement	—	—



**(2) Stapler/crease clock sensor (Stapler Section)**

Relevant electrical parts	
Staple/folding motor clock sensor (PS14) Staple/folding motor (M7)	Finisher control board (FSCB)



Step	Action	WIRING DIAGRAM	
		Control signal	Location (Electrical components)
1	Check the motor and sensor connectors for proper connection, and correct as necessary.	—	—
2	Check the connector of motor for proper drive coupling, and correct as necessary.	—	—
3	PS14 I/O, sensor check	FSCB CN9-5 (ON)	FS-609/PK-501 I-12
4	M7 operation check when the main power switch is turned OFF and ON.	FSCB CN6-3 to 4	FS-609/PK-501 C-4
5	FSCB replacement	—	—

**(3) Home position sensor**

Relevant electrical parts	
Folding home position sensor (PS11) Staple/folding motor (M7)	Finisher control board (FSCB)



Step	Action	WIRING DIAGRAM	
		Control signal	Location (Electrical components)
1	Check the motor and sensor connectors for proper connection, and correct as necessary.	—	—
2	Check the connector of motor for proper drive coupling, and correct as necessary.	—	—
3	PS11 I/O, sensor check	FSCB CN16-6 (ON)	FS-609/PK-501 C-11
4	M7 operation check when the main power switch is turned OFF and ON.	FSCB CN6-3 to 4	FS-609/PK-501 C-4
5	FSCB replacement	—	—

**(4) Stapler/crease clock sensor (Saddle Section)**

Relevant electrical parts	
Staple/folding motor clock sensor (PS14) Staple/folding motor (M7)	Finisher control board (FSCB)



Step	Action	WIRING DIAGRAM	
		Control signal	Location (Electrical components)
1	Check the motor and sensor connectors for proper connection, and correct as necessary.	—	—
2	Check the connector of motor for proper drive coupling, and correct as necessary.	—	—
3	PS14 I/O, sensor check	FSCB CN9-5 (ON)	FS-609/PK-501 I-12
4	M7 operation check when the main power switch is turned OFF and ON.	FSCB CN6-3 to 4	FS-609/PK-501 C-4
5	FSCB replacement	—	—

**9.3.9 C11C1: Punch control board malfunctions**

Relevant electrical parts	
Finisher control board (FSCB) Punch control board (PKCB)	

Step	Action	WIRING DIAGRAM	
		Control signal	Location (Electrical components)
1	Turn OFF the main power switch, wait for 10 sec. or more, and turn ON the main power switch.	—	—
2	Check the connection condition between the punch unit and FSCB.	—	—
3	Measure the voltage between CN14-5 (+) and CN14-3 (-) of the FSCB. Is the voltage 24VDC?	—	—
4	Initialize punch unit EEPROM.	—	—
5	PKCB replacement	—	—
6	FSCB replacement	—	—



**9.3.10 C11C2: Punch side registration motor malfunctions**

Relevant electrical parts	
Side registration home sensor (PS2)	Punch control board (PKCB)



Step	Action	WIRING DIAGRAM	
		Control signal	Location (Electrical components)
1	Check the sensor connectors for proper connection, and correct as necessary.	—	—
2	PS2 I/O, sensor check	PKCB J1006-3 (ON)	FS-609/PK-501 J-3
3	PKCB replacement	—	—

**9.3.11 C11C3: Punch motor malfunctions**

Relevant electrical parts	
Punch home position sensor (PS1) Punch motor clock sensor (PS3) Punch motor (M1)	Punch control board (PKCB)



Step	Action	WIRING DIAGRAM	
		Control signal	Location (Electrical components)
1	Check the motor and sensor connectors for proper connection, and correct as necessary.	—	—
2	Check the connector of motor for proper drive coupling, and correct as necessary.	—	—
3	PS1 I/O, sensor check	PKCB J1006-6 (ON)	FS-609/PK-501 J-3
4	PS3 I/O, sensor check	PKCB J1006-9 (ON)	FS-609/PK-501 J-3 to 4
5	M1 operation check when the main power switch is turned OFF and ON.	PKCB J1002-1 to 2	FS-609/PK-501 J-2
6	PKCB replacement	—	—

**9.3.12 C11C5: Punch sensor malfunctions**

**(1) Side registration sensor**

Relevant electrical parts	
Side registration home sensor (PS2)	Punch control board (PKCB)



Step	Action	WIRING DIAGRAM	
		Control signal	Location (Electrical components)
1	Check the sensor connectors for proper connection, and correct as necessary.	—	—
2	PS2 I/O, sensor check	PKCB J1006-3 (ON)	FS-609/PK-501 J-3
3	PKCB replacement	—	—

**(2) Wastes full sensor**

Relevant electrical parts	
Punch Trash Full Photo Sensor Board (PTFB/PR) Punch Trash Full LED Board (PTFB/LED)	Punch control board (PKCB)

Step	Action	WIRING DIAGRAM	
		Control signal	Location (Electrical components)
1	Check the connection condition between PKCB and PTFB/PR.	—	—
2	Check the connection condition between PWB-B PK and PTFB/LED.	—	—
3	PTFB/PR replacement	—	—
4	PTFB/LED replacement	—	—
5	PKCB replacement	—	—

**(3) Finisher control board**

Relevant electrical parts	
Exit tray home position sensor (PS9) Lift motor clock sensor (PS17) Lift motor (M6)	Finisher control board (FSCB)



Step	Action	WIRING DIAGRAM	
		Control signal	Location (Electrical components)
1	Check the motor and sensor connectors for proper connection, and correct as necessary.	—	—
2	Check the connector of motor for proper drive coupling, and correct as necessary.	—	—
3	PS9 I/O sensor check	FSCB CN5-12 (ON)	FS-609/PK-501 I-8
4	PS17 I/O sensor check	FSCB CN15-6 (ON)	FS-609/PK-501 I-6
5	M6 operation check when the main power switch is turned OFF and ON.	FSCB CN6-1 to 2	FS-609/PK-501 C-4
6	FSCB replacement	—	—

**9.3.13 C1401: Backup RAM malfunction**

Relevant electrical parts	
Finisher control board (FSCB)	

Step	Action	WIRING DIAGRAM	
		Control signal	Location (Electrical components)
1	Disconnect and then connect the power cord. Turn OFF the main power switch, wait for 10 sec. or more, and turn ON the main power switch.	—	—
2	Check the connectors for proper connection on the FSCB.	—	—
3	FSCB replacement	—	—



KONICA MINOLTA

© 2007 KONICA MINOLTA BUSINESS TECHNOLOGIES, INC.

Use of this manual should be strictly supervised to  
avoid disclosure of confidential information.

Printed in Japan  
DDA02E-M-FE3-0800